

(19) (KR)  
(12) (B1)

(51) 。 Int. Cl.7  
C06C 9/00

(45)  
(11)  
(24)

2004 07 30  
10-0442551  
2004 07 21

(21) 10-2001-0065451  
(22) 2001 10 23

(65)  
(43)

10-2001-0100175  
2001 11 14

(73) 358-7 32 11

(72) 358-7 32 11

(74)  
:

(54)

가

0) ; (12) (14) (24) (1  
(34) ; (32) ; (36) ;  
(10) (40) (38);

2

, , , ,

1  
2  
3  
4  
5



(18) ; (20) ; (14)	(16) (14) (20) (24);	(14) (22)	(14) (40)	2	(22); 1mm
100mm	(22)	(14)	(14)		
	(12)	0.1~99%	가		
1		2	3	4	5
		4	6		
2	(10)	(14)	(14)	(16)	(18)
12)					
16)					
)	(18)	(16)			(20)
	(10)		(22)		
(20)	(22)	(24)	(10)		(22)
(24)		(26)	2		
		가			
(12)		(24)			
(10)	(14)		(12)		
		가			
Al(NO3)3 + 5Al	3Al2O3 + 3N( )	1,000	가		20
,000					
6NaNO3 + 10Al	3Na2O + 5Al2O3 + 3N2( )	1,200			15,00
0					
가	(賤)	가			
4NaNO3 + CuSO4 + 10Al	2Na2O + Cu + 5Al2O3	800			15
,000					
4NaNO3 + Fe2SO4 + 10Al	2Na2O + Fe + SO2 + 5Al2O3 + 2N2( )	800			
15,000					
2Ca(NO3)2 + 4FeOOH + 3Mn	CaO + 2FeO + 3Mn3O4 + 2H2O( ) + 2N2( )				
	가				
.1 20mm		(12)		0.1~99%	가
3			(30)		/
(ON/OFF)	1(SW1)				(32)
)	(30)	(32)			
(34)			(34)		(36)
		(32)	(34)		(SW2)
	1(SW1) (ON)	(36)	(SW2) (ON)	(34)	
	(DC)				
(36)		(38)			
(36)		(SW3)	(38)		
(38)	+, - (40)	2	(10)	(42)	(44)

(10) (36) 40) (38) (42) (30) (DC) 3kV 4kV (SW3) (ON) (36) (40) 2 3 (10) ( 1/1,000 ) (40,000 60,000kg/cm<sup>2</sup>) (12) (24) 가 (12) 가 (26) (12) 가 1,000 가 (4) (23) (10) (16) (14) (22, 23) 5 가 (24) 1mm 100mm (10) (14) (26) (12) 6 (23) (16) (14) (10) 2 가 (24) (24) (10) 3kV 4kV (24) 가 (26) (10) 가 6kV 가 (26) (10) 가

- (57)
- 1.
  - 2.
- (36) , (34) , (36) (32) , (34) (40) (38) , (42) (36)

(40) (36) 가 ,  
 (42) (10) ; (10) ,  
 (12) , (14) ,  
 (14) (16) , (18) ,  
 (16) (14) (20)  
 , (14) (40) 2 (22) ,  
 (14) (20) (22) (24);  
 (24) (26);

3.

2 , (23) (14) (14)

4.

(32) , (36) , (34) , (34) (40) (36) 가 (40) (38) , (42) (36)  
 (36) , (36) (40) (36) 가 (40) (38) , (42) (36)  
 (40) (10) (36) 가 (40) (38) , (42) (36)  
 (42) (10) ; 가 (12) , (14) ,  
 (12) (14) ,  
 (14) (16) , (18) ,  
 (16) (14) (20)  
 , (14) (40) 2 (22) ,  
 (14) (20) (22) (24); 1mm  
 100mm

5.

4 , (23) (14) (14)

6.

2 , (12) 0.1~99% 가

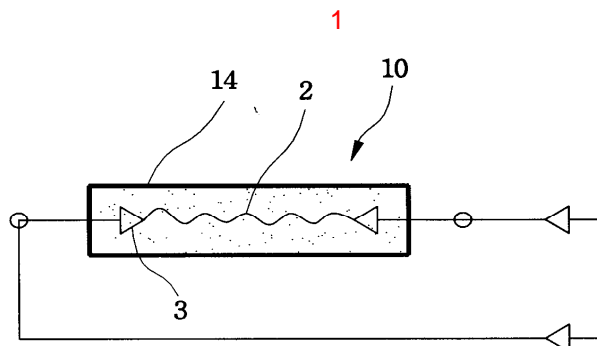

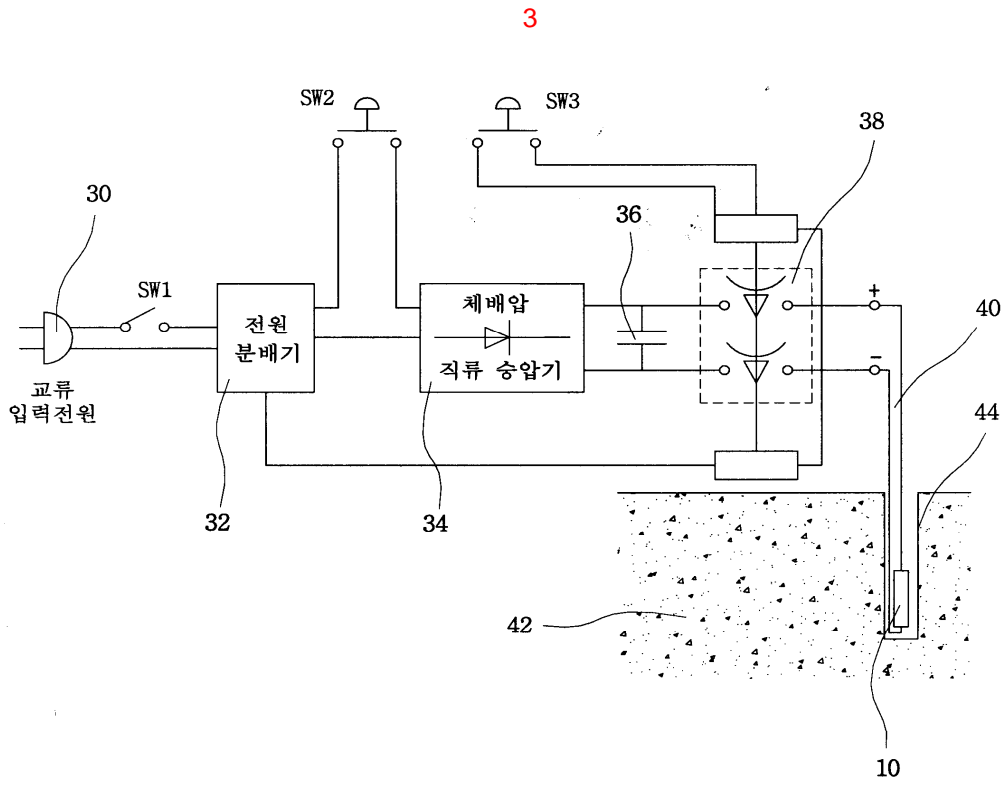
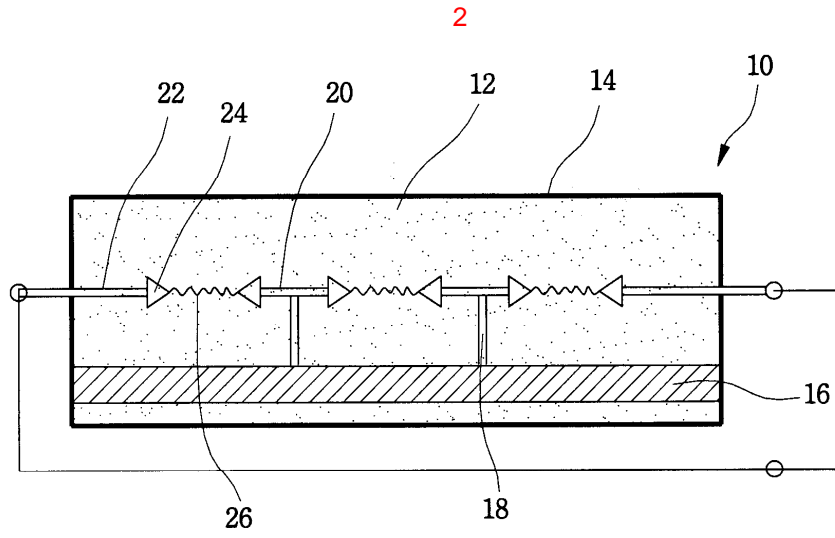

4

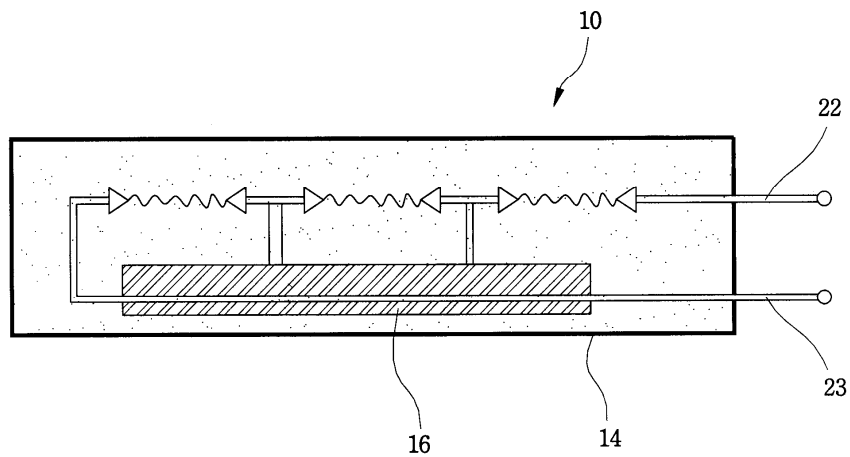

5

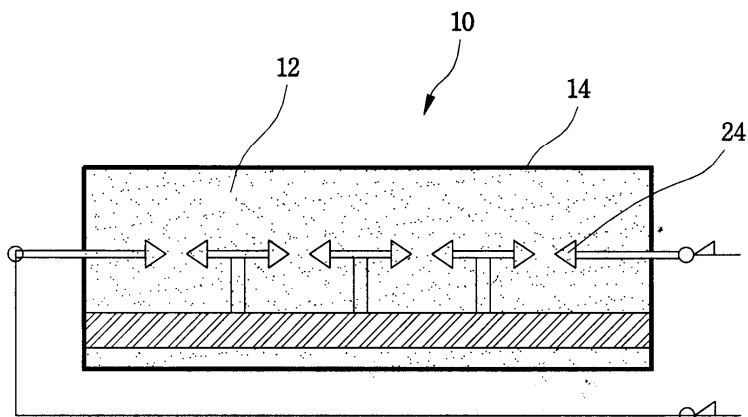

6

