



(51) International Patent Classification:  
E21B 7/15 (2006.01)

(21) International Application Number:

PCT/US2012/026280

(22) International Filing Date:

23 February 2012 (23.02.2012)

(25) Filing Language:

English

(26) Publication Language:

English

(30) Priority Data:

61/446,043	24 February 2011 (24.02.2011)
61/446,042	24 February 2011 (24.02.2011)
61/446,040	24 February 2011 (24.02.2011)
61/446,312	24 February 2011 (24.02.2011)
13/210,581	16 August 2011 (16.08.2011)

(71) Applicant (for all designated States except US): **FORO ENERGY, INC.** [US/US]; 8020 Southpark Circle, Suite 500, Denver, CO 80120 (US).

(72) Inventors; and

(75) Inventors/Applicants (for US only): **GRUBB, Daryl, L.** [US/US]; 11135 Muleshoe Court, Houston, TX 77095 (US). **FAIRCLOTH, Brian, O.** [US/US]; 7664 Brook Forest Lane, Evergreen, CO 80439 (US). **ZEDIKER, Mark, S.** [US/US]; 1896 Via De Los Pinons, Castle Rock, CO 80104 (US).

(74) Agent: **FREEMAN, John, C.**; Brinks Hofer Gilson & Li-one, P.O. Box 10087, Chicago, IL 60610 (US).

(81) Designated States (unless otherwise indicated, for every kind of national protection available): AE, AG, AL, AM, AO, AT, AU, AZ, BA, BB, BG, BH, BR, BW, BY, BZ, CA, CH, CL, CN, CO, CR, CU, CZ, DE, DK, DM, DO, DZ, EC, EE, EG, ES, FI, GB, GD, GE, GH, GM, GT, HN,

[Continued on next page]

(54) Title: ELECTRIC MOTOR FOR LASER-MECHANICAL DRILLING

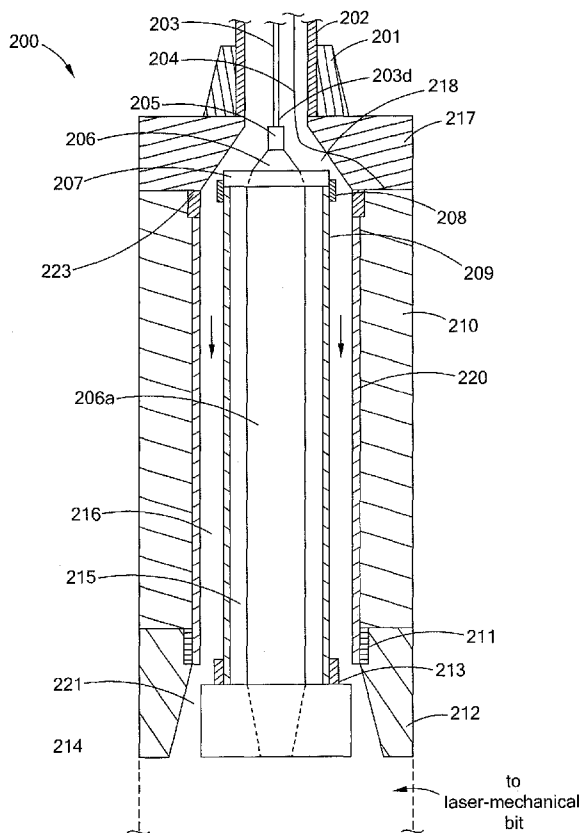

Fig. 2

(57) Abstract: There is provided a high power laser drilling system utilizing an electric motor laser bottom hole assembly having the high power laser beam traveling within the electric motor for advancing a borehole. The systems may include a down hole electrical motor having a hollow rotor for conveying a high power laser beam through the motor.

WO 2012/116155 A1



HR, HU, ID, IL, IN, IS, JP, KE, KG, KM, KN, KP, KR, KZ, LA, LC, LK, LR, LS, LT, LU, LY, MA, MD, ME, MG, MK, MN, MW, MX, MY, MZ, NA, NG, NI, NO, NZ, OM, PE, PG, PH, PL, PT, QA, RO, RS, RU, RW, SC, SD, SE, SG, SK, SL, SM, ST, SV, SY, TH, TJ, TM, TN, TR, TT, TZ, UA, UG, US, UZ, VC, VN, ZA, ZM, ZW.

UG, ZM, ZW), Eurasian (AM, AZ, BY, KG, KZ, MD, RU, TJ, TM), European (AL, AT, BE, BG, CH, CY, CZ, DE, DK, EE, ES, FI, FR, GB, GR, HR, HU, IE, IS, IT, LT, LU, LV, MC, MK, MT, NL, NO, PL, PT, RO, RS, SE, SI, SK, SM, TR), OAPI (BF, BJ, CF, CG, CI, CM, GA, GN, GQ, GW, ML, MR, NE, SN, TD, TG).

**(84) Designated States** (unless otherwise indicated, for every kind of regional protection available): ARIPO (BW, GH, GM, KE, LR, LS, MW, MZ, NA, RW, SD, SL, SZ, TZ,

**Published:**

— with international search report (Art. 21(3))

**ELECTRIC MOTOR FOR LASER-MECHANICAL DRILLING**

5           **[0001]**    This application: (i) claims, under 35 U.S.C. §119(e)(1), the benefit of the filing date of February 24, 2011 of US provisional application serial number 61/446,042; (ii) claims, under 35 U.S.C. §119(e)(1), the benefit of the filing date of February 24, 2011 of US provisional application serial number 61/446,043; (iii) claims, under 35 U.S.C. §119(e)(1), the benefit of the filing date of February 24, 2011 of US  
10 provisional application serial number 61/446,040; (iv) claims, under 35 U.S.C. §119(e)(1), the benefit of the filing date of February 24, 2011 of US provisional application serial number 61/446,312; and (v) is a continuation-in-part of US patent application serial number 13/210,581 filed August 16, 2011, the entire disclosures of each of which are incorporated herein by reference.

15           **[0002]**    This invention was made with Government support under Award DE-AR0000044 awarded by the Office of ARPA-E U.S. Department of Energy. The Government has certain rights in this invention.

**BACKGROUND OF THE INVENTION****Field of the Invention**

20           **[0003]**    The present inventions relate to electric motors for use down hole in laser-mechanical drilling and to high power laser drilling systems.

**[0004]**    As used herein, unless specified otherwise "high power laser energy" means a laser beam having at least about 1 kW (kilowatt) of power. As used herein, unless specified otherwise "great distances" means at least about 500 m (meter). As  
25 used herein, unless specified otherwise, the term "substantial loss of power," "substantial power loss" and similar such phrases, mean a loss of power of more than about 3.0 dB/km (decibel/kilometer) for a selected wavelength. As used herein, unless specified otherwise, the term "substantial power transmission" means at least about 50% transmittance.

30           **[0005]**    As used herein the term "earth" should be given its broadest possible meaning, and includes, the ground, all natural materials, such as rocks, and artificial materials, such as concrete, that are or may be found in the ground, including without

limitation rock layer formations, such as, granite, basalt, sandstone, dolomite, sand, salt, limestone, rhyolite, quartzite and shale rock.

[0006] As used herein, unless specified otherwise, the term "borehole" should be given its broadest possible meaning and includes any opening that is created in a material, a work piece, a surface, the earth, a structure (e.g., building, protected military installation, nuclear plant, offshore platform, or ship), or in a structure in the ground, (e.g., foundation, roadway, airstrip, cave or subterranean structure) that is substantially longer than it is wide, such as a well, a well bore, a well hole, a micro hole, slimhole, a perforation and other terms commonly used or known in the arts to define these types of narrow long passages. Wells would further include exploratory, production, abandoned, reentered, reworked, and injection wells. Although boreholes are generally oriented substantially vertically, they may also be oriented on an angle from vertical, to and including horizontal. Thus, using a vertical line, based upon a level as a reference point, a borehole can have orientations ranging from 0° *i.e.*, vertical, to 90° *i.e.*, horizontal and greater than 90° *e.g.*, such as a heel and toe and combinations of these such as for example "U" and "Y" shapes. Boreholes may further have segments or sections that have different orientations, they may have straight sections and arcuate sections and combinations thereof; and for example may be of the shapes commonly found when directional drilling is employed. Thus, as used herein unless expressly provided otherwise, the "bottom" of a borehole, the "bottom surface" of the borehole and similar terms refer to the end of the borehole, *i.e.*, that portion of the borehole furthest along the path of the borehole from the borehole's opening, the surface of the earth, or the borehole's beginning. The terms "side" and "wall" of a borehole should be given their broadest possible meaning and include the longitudinal surfaces of the borehole, whether or not casing or a liner is present, as such, these terms would include the sides of an open borehole or the sides of the casing that has been positioned within a borehole. Boreholes may be made up of a single passage, multiple passages, connected passages and combinations thereof, in a situation where multiple boreholes are connected or interconnected each borehole would have a borehole bottom. Boreholes may be formed in the sea floor, under bodies of water, on land, in ice formations, or in other locations and settings.

**[0007]** Boreholes are generally formed and advanced by using mechanical drilling equipment having a rotating drilling tool, *e.g.*, a bit. For example and in general, when creating a borehole in the earth, a drilling bit is extending to and into the earth and rotated to create a hole in the earth. In general, to perform the drilling operation the bit  
5 must be forced against the material to be removed with a sufficient force to exceed the shear strength, compressive strength or combinations thereof, of that material. Thus, in conventional drilling activity mechanical forces exceeding these strengths of the rock or earth must be applied. The material that is cut from the earth is generally known as cuttings, *e.g.*, waste, which may be chips of rock, dust, rock fibers and other types of  
10 materials and structures that may be created by the bit's interactions with the earth. These cuttings are typically removed from the borehole by the use of fluids, which fluids can be liquids, foams or gases, or other materials known to the art.

**[0008]** As used herein, unless specified otherwise, the term "advancing" a borehole should be given its broadest possible meaning and includes increasing the  
15 length of the borehole. Thus, by advancing a borehole, provided the orientation is not horizontal, *e.g.*, less than 90° the depth of the borehole may also be increased. The true vertical depth ("TVD") of a borehole is the distance from the top or surface of the borehole to the depth at which the bottom of the borehole is located, measured along a straight vertical line. The measured depth ("MD") of a borehole is the distance as  
20 measured along the actual path of the borehole from the top or surface to the bottom. As used herein unless specified otherwise the term depth of a borehole will refer to MD. In general, a point of reference may be used for the top of the borehole, such as the rotary table, drill floor, well head or initial opening or surface of the structure in which the borehole is placed.

**[0009]** As used herein, unless specified otherwise, the terms "ream", "reaming", a borehole, or similar such terms, should be given their broadest possible meaning and includes any activity performed on the sides of a borehole, such as, *e.g.*,  
25 smoothing, increasing the diameter of the borehole, removing materials from the sides of the borehole, such as *e.g.*, waxes or filter cakes, and under-reaming.

**[0010]** As used herein, unless specified otherwise, the terms "drill bit", "bit", "drilling bit" or similar such terms, should be given their broadest possible meaning and  
30

include all tools designed or intended to create a borehole in an object, a material, a work piece, a surface, the earth or a structure including structures within the earth, and would include bits used in the oil, gas and geothermal arts, such as fixed cutter and roller cone bits, as well as, other types of bits, such as, rotary shoe, drag-type, fishtail, adamantine, single and multi-toothed, cone, reaming cone, reaming, self-cleaning, disc, 5 three-cone, rolling cutter, crossroller, jet, core, impreg and hammer bits, and combinations and variations of the these.

**[0011]** In general, in a fixed cutter bit there are no moving parts. In these bits drilling occurs when the entire bit is rotated by, for example, a rotating drill string, a mud 10 motor, or other means to turn the bit. Fixed cutter bits have cutters that are attached to the bit. These cutters mechanically remove material, advancing the borehole as the bit is turned. The cutters in fixed cutter bits can be made from materials such as polycrystalline diamond compact ("PDC"), grit hotpressed inserts ("GHI"), and other materials known to the art or later developed by the art.

**[0012]** In general, a roller cone bit has one, two, three or more generally 15 conically shaped members, e.g., the roller cones, that are connected to the bit body and which can rotate with respect to the bit. Thus, as the bit is turned, and the cones contact the bottom of a borehole, the cones rotate and in effect roll around the bottom of the borehole. In general, the cones have, for example, tungsten carbide inserts ("TCI") 20 or milled teeth ("MT"), which contact the bottom, or other surface, of the borehole to mechanically remove material and advance the borehole as the bit it turned.

**[0013]** In both roller cone, fixed bits, and other types of mechanical drilling the state of the art, and the teachings and direction of the art, provide that to advance a borehole great force should be used to push the bit against the bottom of the borehole 25 as the bit is rotated. This force is referred to as weight-on-bit ("WOB"). Typically, tens of thousands of pounds WOB are used to advance a borehole using a mechanical drilling process.

**[0014]** Mechanical bits cut rock by applying crushing (compressive) and/or shear stresses created by rotating a cutting surface against the rock and placing a large 30 amount of WOB. In the case of a PDC bit this action is primarily by shear stresses and in the case of roller cone bits this action is primarily by crushing (compression) and

shearing stresses. For example, the WOB applied to an 8 3/4" PDC bit may be up to 15,000 lbs, and the WOB applied to an 8 3/4" roller cone bit may be up to 60,000 lbs. When mechanical bits are used for drilling hard and ultra-hard rock excessive WOB, rapid bit wear, and long tripping times result in an effective drilling rate that is essentially economically unviable. The effective drilling rate is based upon the total time  
5 necessary to complete the borehole and, for example, would include time spent tripping in and out of the borehole, as well as, the time for repairing or replacing damaged and worn bits.

**[0015]** As used herein, unless specified otherwise, the term "drill pipe" should  
10 be given its broadest possible meaning and includes all forms of pipe used for drilling activities; and refers to a single section or piece of pipe, as well as, multiple pipes or sections. As used herein, unless specified otherwise, the terms "stand of drill pipe," "drill pipe stand," "stand of pipe," "stand" and similar type terms should be given their broadest possible meaning and include two, three or four sections of drill pipe that have  
15 been connected, *e.g.*, joined together, typically by joints having threaded connections. As used herein, unless specified otherwise, the terms "drill string," "string," "string of drill pipe," "string of pipe" and similar type terms should be given their broadest definition and would include a stand or stands joined together for the purpose of being employed in a borehole. Thus, a drill string could include many stands and many hundreds of sections  
20 of drill pipe.

**[0016]** As used herein, unless specified otherwise, the term "tubular" should be given its broadest possible meaning and includes drill pipe, casing, riser, coiled tube, composite tube, vacuum insulated tubing ("VIT"), production tubing and any similar structures having at least one channel therein that are, or could be used, in the drilling  
25 industry. As used herein the term "joint" should be given its broadest possible meaning and includes all types of devices, systems, methods, structures and components used to connect tubulars together, such as for example, threaded pipe joints and bolted flanges. For drill pipe joints, the joint section typically has a thicker wall than the rest of the drill pipe. As used herein the thickness of the wall of tubular is the thickness of the  
30 material between the internal diameter of the tubular and the external diameter of the tubular.

**[0017]** As used herein the term "line structure" should be given its broadest meaning, unless specifically stated otherwise, and would include without limitation: wire line; coiled tubing; slick line; logging cable; cable structures used for completion, workover, drilling, seismic, sensing, and logging; cable structures used for subsea completion and other subsea activities; umbilicals; cables structures used for scale removal, wax removal, pipe cleaning, casing cleaning, cleaning of other tubulars; cables used for ROV control power and data transmission; lines structures made from steel, wire and composite materials, such as carbon fiber, wire and mesh; line structures used for monitoring and evaluating pipeline and boreholes; and would include without limitation such structures as Power & Data Composite Coiled Tubing (PDT-COIL) and structures such as Smart Pipe<sup>®</sup> and FLATpak<sup>®</sup>.

**[0018]** As used herein, unless specified otherwise the terms "blowout preventer," "BOP," and "BOP stack" should be given their broadest possible meaning, and include: (i) devices positioned at or near the borehole surface, *e.g.*, the surface of the earth including dry land or the seafloor, which are used to contain or manage pressures or flows associated with a borehole; (ii) devices for containing or managing pressures or flows in a borehole that are associated with a subsea riser or a connector; (iii) devices having any number and combination of gates, valves or elastomeric packers for controlling or managing borehole pressures or flows; (iv) a subsea BOP stack, which stack could contain, for example, ram shears, pipe rams, blind rams and annular preventers; and, (v) other such similar combinations and assemblies of flow and pressure management devices to control borehole pressures, flows or both and, in particular, to control or manage emergency flow or pressure situations.

**[0019]** As used herein, unless specified otherwise "offshore" and "offshore drilling activities" and similar such terms are used in their broadest sense and would include drilling activities on, or in, any body of water, whether fresh or salt water, whether manmade or naturally occurring, such as for example rivers, lakes, canals, inland seas, oceans, seas, bays and gulfs, such as the Gulf of Mexico. As used herein, unless specified otherwise the term "offshore drilling rig" is to be given its broadest possible meaning and would include fixed towers, tenders, platforms, barges, jack-ups, floating platforms, drill ships, dynamically positioned drill ships, semi-submersibles and



dynamically positioned semi-submersibles. As used herein, unless specified otherwise the term "seafloor" is to be given its broadest possible meaning and would include any surface of the earth that lies under, or is at the bottom of, any body of water, whether fresh or salt water, whether manmade or naturally occurring.

5           **[0020]** As used herein, unless specified otherwise the term "fixed platform," would include any structure that has at least a portion of its weight supported by the seafloor. Fixed platforms would include structures such as: free-standing caissons, well-protector jackets, pylons, braced caissons, piled-jackets, skirted piled-jackets, compliant towers, gravity structures, gravity based structures, skirted gravity structures,  
10 concrete gravity structures, concrete deep water structures and other combinations and variations of these. Fixed platforms extend from at or below the seafloor to and above the surface of the body of water, *e.g.*, sea level. Deck structures are positioned above the surface of the body of water a top of vertical support members that extend down in to the water to the seafloor. Fixed platforms may have a single vertical support, or  
15 multiple vertical supports, *e.g.*, pylons, legs, etc., such as a three, four, or more support members, which may be made from steel, such as large hollow tubular structures, concrete, such as concrete reinforced with metal such as rebar, and combinations of these. These vertical support members are joined together by horizontal and other support members. In a piled-jacket platform the jacket is a derrick-like structure having  
20 hollow essentially vertical members near its bottom. Piles extend out from these hollow bottom members into the seabed to anchor the platform to the seabed.

#### SUMMARY

**[0021]** There has been a long standing need for down hole tools, bottom hole  
25 assemblies, and drilling systems that utilize a down hole electric motor as the source for rotational movement of the drilling bit and conveyance of a high power laser beam there through, as well as, a drilling system that can advance a borehole with reduced weight on bit when compared to conventional drilling technology. The present inventions, among other things, solve these and other needs by providing the articles of  
30 manufacture, devices and processes taught herein.

**[0022]** There is provided a high power laser electric motor assembly including: a first section associated with a second section; the second section rotationally associated with a third section; the first section including a means for receiving a high power laser beam, a means for collimating the laser beam, and a first fluid cavity; the  
5 second section including an inner cavity and a second fluid cavity; a laser beam path extending through the inner cavity, in this manner the laser beam path is in collimated space; and, the third section including an optics assembly, and a third fluid cavity; a first rotary sealing means associating the first and second sections; a second rotary sealing means associating the second and the third sections; in this manner, the means for  
10 collimating the laser beam, the second section inner cavity and the third section optics assembly are in optical communication, and in this manner the first fluid cavity, the second fluid cavity and the third fluid cavity are in fluid communication.

**[0023]** Further, there are provided high power laser electric motor assemblies and systems that may also include: the second section having an electric motor; the  
15 electric motor having a hollow rotor defining the inner cavity; the inner cavity being in fluid isolation from the second cavity; the second cavity being formed between a rotor and a stator; the inner cavity partially defined by a beam path tube; the inner cavity defined by a beam path tube; the first, the second or the third section have an electric motor; an electric motor having a hollow rotor defining the beam path tube; the means  
20 for receiving the high power laser beam is in optical communication with a high power optical laser fiber that is in optical communication with a high power laser beam source; the means for receiving the high power laser beam is in optical communication with a conveyance structure that is in optical communication with a high power laser beam source having greater than about 5 kW of power; the means for receiving the high  
25 power laser beam is in optical communication with a conveyance structure that is in optical communication with a high power laser beam source having greater than about 10 kW of power; the means for receiving the high power laser beam is in optical communication with a conveyance structure that is in optical communication with a high power laser beam source having greater than about 80 kW of power; the means for  
30 receiving the high power laser beam is in optical communication with a high power optical laser fiber that is in optical communication with a high power laser beam source

having greater than about 20 kW of power; the means for receiving the high power laser beam is in optical communication with a high power optical laser fiber that is in optical communication with a high power laser beam source having greater than about 60 kW of power; the means for receiving the high power laser beam is in optical  
5 communication with a high power optical laser fiber that is in optical communication with a high power laser beam source having greater than about 100 kW of power; the means for receiving the high power laser beam is in optical communication with a high power optical laser fiber that is in optical communication with a high power laser beam source, and in this manner the high power laser beam source has a plurality of high power  
10 lasers; the means for receiving the high power laser beam is in optical communication with a high power optical laser fiber that is in optical communication with a high power laser beam source having greater than about 60 kW of power, and in this manner the high power laser beam source has a plurality of high power lasers; the means for receiving the high power laser beam is in optical communication with a high power  
15 optical laser fiber that is in optical communication with a high power laser beam source having greater than about 80 kW of power, and in this manner the high power laser beam source has a plurality of high power lasers; and the electric motor being a permanent magnet motor.

**[0024]** Still further, there is provided a high power laser electric motor  
20 assembly including: a first section associated with a second section; the second section rotationally associated with a third section; the first section including a means for receiving a high power laser beam, a means for collimating the laser beam, and a first fluid cavity; the second section including an inner cavity and a second fluid cavity; a laser beam path extending through the inner cavity, in this manner the laser beam path  
25 is in collimated space; and, the third section including an optics assembly, and a third fluid cavity; a first rotary sealing means associating the first and second sections; a second rotary sealing means associating the second and the third sections; in this manner, the means for collimating the laser beam, the second section inner cavity and the third section optics assembly are in optical communication, and in this manner the  
30 first fluid cavity, the second fluid cavity and the third fluid cavity are in fluid

communication, in which the second section has a rare earth permanent magnet motor an electric.

**[0025]** Furthermore, there is provided a high power laser electric motor assembly including: a first section associated with a second section; the second section  
5 rotationally associated with a third section; the first section including a means for receiving a high power laser beam, a means for collimating the laser beam, and a first fluid cavity; the second section including an inner cavity and a second fluid cavity; a laser beam path extending through the inner cavity, in this manner the laser beam path is in collimated space; and, the third section including an optics assembly, and a third  
10 fluid cavity; a first rotary sealing means associating the first and second sections; a second rotary sealing means associating the second and the third sections; in this manner, the means for collimating the laser beam, the second section inner cavity and the third section optics assembly are in optical communication, and in this manner the first fluid cavity, the second fluid cavity and the third fluid cavity are in fluid  
15 communication, in which the second section has a rare earth permanent magnet motor an electric having a hollow rotor defining the inner cavity

**[0026]** Yet still further, there are provided high power laser electric motor assemblies and systems that may also include: a bent sub and a means for transmitting the high power laser beam across the bent sub; a tractor; a bent sub having an optical  
20 wedge assembly; a laser beam path in the hollow rotor in collimated space; a laser beam path in the hollow rotor is in free space; the conveyance structure having three high power optical fibers; the conveyance structure has four high power optical fibers; a laser source capable of providing a laser beam having a power of at least about 90 kW and the conveyance structure has five high power optical fibers; and a bent sub and a  
25 means for transmitting the high power laser beam across the bent sub.

**[0027]** Additionally, there is provided an electric motor laser bottom hole assembly drilling system including: a high power laser source, having the capability to provide a laser beam having a power of greater than about 50 kW; an electrical power source; a conveyance structure; an electric motor bottom hole assembly; the  
30 conveyance structure optically associating the laser source and the electric motor bottom hole assembly, and the conveyance structure electrically associating the

electrical power source and the electric motor bottom hole assembly; the electric motor bottom hole assembly including: an electric motor having a hollow rotor, and a laser-mechanical bit; and, a laser beam path extending through the hollow rotor, thus the laser beam from the laser source is transmitted through the hollow rotor to a laser-

5 mechanical bit.

**[0028]** Still additionally, there is provided an electric motor laser bottom hole assembly drilling system including: a high power laser source, having the capability to provide a laser beam having a power of greater than about 50 kW; an electrical power source; a conveyance structure; an electric motor bottom hole assembly; the

10 conveyance structure optically associating the laser source and the electric motor bottom hole assembly, and the conveyance structure electrically associating the electrical power source and the electric motor bottom hole assembly; the electric motor bottom hole assembly including: a first optical package, a second optical package, an electric motor having a hollow rotor, and a laser-mechanical bit, in this manner the first

15 optical package has a collimating optic; a beam path tube partially within the hollow rotor and optically and sealingly associating the first optics package and the second optics package; the second optical package optically associated with the laser-mechanic bit; and, a laser beam path extending through the beam path tube, thus the laser beam from the laser source is transmitted through the beam path tube in

20 collimated space to the second optical package and to the laser-mechanical bit.

**[0029]** Further, there is provided a system for performing high power laser operations including: a high power laser source; the high power laser in optical association with a high power laser fiber; the high power laser fiber in optical communication with a first optical package in an electric motor laser bottom hole

25 assembly; the first optical package in optical communication with a second optical package and defining a laser beam path between the first and second optical packages; and, the laser beam path being at least partly located within a section of the electric motor where rotation takes place upon operation of the motor.

**[0030]** Still further, there is provided a method of laser-mechanical directional

30 drilling including: providing an electric motor laser bottom hole assembly system to a borehole at a borehole site, the system including an electric motor laser bottom hole

assembly and a high power laser source, the electric motor bottom hole assembly including a pair of optical wedges; lowering the laser bottom hole assembly into the borehole; configuring the optical wedges to define an angled laser beam path; delivering a high power laser beam having at least about 20 kW to the electrical motor laser  
5 bottom hole assembly, in this manner the high power laser beam is transmitted through the configured optical wedges; in this manner the angled beam path correlates with a directional drilling path and thus the borehole is advanced along the directional drilling path.

**[0031]** Moreover, there is also provided a method of advancing a borehole by:  
10 providing a system for performing high power laser operations including: a high power laser source; the high power laser in optical association with a high power laser fiber; the high power laser fiber in optical communication with a first optical package in an electric motor laser bottom hole assembly; the first optical package in optical  
15 communication with a second optical package and defining a laser beam path between the first and second optical packages; and, the laser beam path being at least partly located within a section of the electric motor where rotation takes place upon operation of the motor; lowering the system into a borehole and rotating the electric motor while propagating a laser beam through the electric motor bottom hole assembly to thereby  
20 advance the borehole.

#### BRIEF DESCRIPTION OF THE DRAWINGS

**[0032]** FIG. 1 is a schematic view of an embodiment of an electric motor laser bottom hole assembly ("EM-LBHA") system in accordance with the present invention.

25 **[0033]** FIG. 1A is an enlarged view of the electric motor laser bottom hole assembly of FIG. 1.

**[0034]** FIG. 2 is a cross-sectional view of an embodiment of an EM-LBHA in accordance with the present invention.

30 **[0035]** FIG. 3 is a schematic view of an embodiment of an EM-LBHA in accordance with the present invention.

**[0036]** FIG. 4 is a schematic view on an embodiment of an EM-LBHA system in accordance with the present invention.

**[0037]** FIG. 5 is a schematic view of an embodiment of a mobile EM-LBHA unit in accordance with the present invention.

5 **[0038]** FIGS. 6, 6A and 6B are schematic views of an embodiment of beam paths and wedges for use in a bent sub configuration in accordance with the present invention.

#### DESCRIPTION OF THE PREFERRED EMBODIMENTS

10 **[0039]** The present inventions relate to downhole electric motor assemblies and systems for use with laser-mechanical bits and to laser-mechanical drilling systems.

**[0040]** Turning to FIG. 1 there is shown a borehole 102 having a well head 104, a BOP 105 and a diverter 106, or other assembly to maintain pressure and handle the return of drilling fluids to the surface 103. Conveyance structure 101, which may be  
15 a line structure, is shown extending into the borehole 102 and down to and being connected with an embodiment of an electric motor laser bottom hole assembly (EM-LBHA) 100. There is also a whipstock 109 and casing 108 in the borehole, and the borehole has been advanced in a primarily horizontal direction from the general location of the whipstock 109 in the borehole 108. The conveyance structure 101 would be  
20 connected to a drilling unit, workover and completion unit, or similar type of unit and laser assembly (not shown in this drawing).

**[0041]** FIG. 1A shows a more detailed view of the EM-LBHA 100 and sets forth the general components that that may make up an EM-LBHA. It being recognized that additional general components may be added or used and that, applying the  
25 teachings of this specification, the order and arrangement of these components may be varied, without departing from the spirit of the inventions.

**[0042]** In FIG. 1A, the EM-LBHA 100 has a conveyance structure 101 in mechanical, and fluid communication with an upper motor section 121 by way of a conveyance structure connector 120. The upper motor section 121 is connected to the  
30 motor section 123, below the motor section is a lower motor section 122, and below the lower motor section 123 is a laser-mechanical bit 124.

**[0043]** In general, and by way of example, the upper section of the EM-LBHA may contain a flow passage, and flow regulator and control devices, for a fluid that is transported down a channel associated with the conveyance structure. The conveyance structure, preferably is a line structure, which may have multiple channels  
5 for transporting different materials, cables, or lines to the EM-LBHA and the borehole. The channels may be in, on, integral with, releasably connected to, or otherwise associated with the line structure, and combinations and variations of these. Further examples of conveyance structures are disclosed and taught in the following US Patent Applications and US Patent Application Publications: Publication No. US 2010/0044106,  
10 Publication No. 2010/0215326, Publication No. 2012/0020631, Serial No. 13/210,581, and Serial No. 61/493,174. The fluid may be a gas, a foam, a supercritical fluid, or a liquid. The fluid may be used to cool the high power optics in the EM-LBHA, to cool the motor, to cool other sections, to keep the laser beam path clear of debris, to remove or assist in removing cuttings and other material from the borehole, the bottom of the  
15 borehole or the work area, and other uses for downhole fluids known to the art. Typically, a liquid may be used to cool the electric motor components.

**[0044]** The upper section of the EM-LBHA may further have an optical package, which may contain optical elements, optics and be a part of an optical assembly, a means to retain the end of the high power optical fiber(s), and an optical  
20 fiber connector(s) for launching the beam(s) from the fiber into the optical assembly, which connector could range from a bare fiber face to a more complex connector. High power laser connectors known to those of skill in the art may be utilized. Further, examples of connectors are disclosed and taught in the following US Patent Application: Serial No. 61/493,174, the entire disclosure of which is incorporated herein by  
25 reference. The upper section of the EM-LBHA may further have electrical cable management means to handle and position the electrical cable(s), which among other uses, are for providing electric power to the motor section. These electric cable(s) may be contained within, or otherwise associated with, the conveyance structure.

**[0045]** The upper section of the EM-LBHA also may contain handling means  
30 for managing any other cables, conduits, conductors, or fibers that are needed to support the operation of the EM-LBHA. Examples of such cables, conduits, conductors,



or fibers would be for connection to, or association with: a sensor, a break detector, a LWD (logging while drilling assembly), a MWD (measuring while drilling assembly), an RSS (rotary steerable system), a video camera, or other section, assembly component or device that may be included in, or with, the EM-LBHA.

5           **[0046]**     In general, the motor section can be any electric motor that is capable, or is made capable of withstanding the conditions and demands found in a borehole, during drilling, and as a result of the drilling process. The electric motor has a hollow rotating drive shaft, *i.e.*, a hollow rotor, or should be capable of accommodating such a hollow rotor. By way of example, an electronic submersible pump ("ESP") may be used,  
10 or adapted to be used as a motor section for a EM-LBHA.

**[0047]**     The general, the lower section contains an optical package, which may contain optical elements, optics and be a part of an optical assembly, for receiving and shaping and directing the laser beam into a particular pattern. The upper section optical package and the lower section optical package may form, or constitute, an optics  
15 assembly. The lower section optical package, in part, launches (*e.g.*, propagates, shoots) the beam into a beam path or beam channel within the drill bit so that the beam can strike the bottom (and/or side) of the borehole without damaging the bit. The lower section may also contain equipment, assemblies and systems that are capable of, for example, logging, measuring, videoing, sensing, monitoring, reaming, or steering.  
20 Additional lower sections may be added to the EM-LBHA, that may contain equipment, assemblies and systems that are capable of, for example, logging, measuring, videoing, sensing, monitoring, reaming, or steering.

**[0048]**     In general, the laser-mechanical bit that is utilized with an electric motor, EM-LBHA or a laser drilling system, may be any mechanical drill bit, such as a  
25 fixed cutter bit or a roller cone bit that has been modified to accommodate a laser beam, by providing a laser beam path, or is associated with a laser beam and/or optics package. Further examples of laser-mechanical bits, their usage, and the laser-mechanical drilling process are disclosed and taught in the following US Patent Applications and US Patent Application Publications: US 2010/0044106, US  
30 2010/0044105, US 2010/0044104, US 2010/0044103, US 2010/0044102, Serial No. 13/211,729, Serial No. 12/896,021, Serial No. 61/446,043, Serial No. 61/446,041, Serial

No. 61/446,312, co-filed US patent application having attorney docket no. 13938/78 (Foro s3a-1) filed contemporaneously herewith, and co-filed US patent application having attorney docket no. 13938/79 (Foro s13a) filed contemporaneously herewith, the entire disclosure of each of which are incorporated herein by reference.

5           **[0049]** In general, an optical assembly, an optical package, an optical component and an optic, that is utilized with an electric motor, EM-LBHA, or a laser drilling system, may be generally any type of optical element and/or system that is capable of handling the laser beam (*e.g.*, transmitting, reflecting, etc. without being damaged or quickly destroyed by the beams energy), that is capable of meeting the  
10 environmental conditions of use (*e.g.*, down hole temperatures, pressures, vibrates, etc.) and that is capable of effecting the laser beam in a predetermined manner (*e.g.*, focus, de-focus, shape, collimate, steer, scan, etc.). Further examples of optical assemblies, optical packages, optical components and optics are disclosed and taught in the following US Patent Applications and US Patent Application Publications: US  
15 2010/0044105, US 2010/0044104, US 2010/0044103, Serial No. 61/446,040, Serial No. 61/446,312 and co-filed US patent application having attorney docket no. 13938/87 (Foro s3b-1) filed contemporaneously herewith, the entire disclosure of each of which are incorporated herein by reference.

**[0050]** Turning to FIG. 2 there is shown a cross-section view of an  
20 embodiment of an EM-LBHA. Thus, there is provided an EM-LBHA 200 having an upper section 217, a motor section 210, and a lower section 212.

**[0051]** The upper section 217 has a channel 218, which may be annular. Channel 218 is in fluid communication with the conveyance structure 202 and motor channel 216, which may be annular. The upper section 217 also may house, or  
25 contain, the distal end 203d of the optical fiber 203, a connector 205 and optical package 207. The laser beam 206 in FIG. 2 is being launched from (*e.g.*, propagated) from connector 205 into optical package 207. In operation, a high power laser (not shown) generates a high power laser beam that is coupled (*e.g.*, launched into) the proximal end (not shown) of the high power optical fiber 203. The high power laser  
30 beam is transmitted down the optical fiber 203 and is launched from the distal end 203d of the optical fiber 203, into a connector 205, and/or into the optical package 207. The

laser beam travels along path 206 as it is launched into the optical package 207. The laser beam leaves, is launched from, the optical package 207 and travels along beam path 206a through an electric motor beam channel 215 to optical package 214.

**[0052]** In the embodiment of FIG. 2, a connector 205 is used, it being  
5 understood that a fiber face or other manner of launching a high power laser beam from a fiber into an optical element or system may also be used. The optical package 207, in this embodiment of FIG. 2, includes collimating optics; and as such, the laser beam traveling along beam path 206a through the electric motor beam channel 215 is collimated, this beam path 206a may also be referred to as collimated space. In this  
10 manner, the electric motor beam channel 215 is in, coincides with, collimated space.

**[0053]** The optical package 214 may be beam shaping optics, as for example are provided in the above incorporated by reference patent applications, or it may contain optics and/or a connector for transmitting the beam into another high power fiber, for example for transmitting the beam through additional lower section and/or over  
15 greater lengths.

**[0054]** The construction of the motor section preferable should take into consideration the tolerances of the various components of the electric motor when operating and under various external and internal conditions, as they relate to the optical assemblies, beam path and the transmission of the laser beam through the  
20 electric motor. Preferably, these tolerances are very tight, so that variations in the electric motor will not adversely, detrimentally, or substantially adversely, affect the transmission of the laser beam through the electric motor. Further, the optical assemblies, including the optical packages, optics, and optical elements and systems and related fixtures, mounts and housing, should take into consideration the electric  
25 motor tolerances, and may be constructed to compensate for, or otherwise address and mitigate, higher electric motor tolerances than may otherwise be preferably desirable.

**[0055]** The first optical package 207 and the second optical package 214, constitute an optical assembly, and should remain in alignment with respect to each other during operation, preferably principally in all three axes. Axial tolerances, *e.g.*,  
30 changes in the length of the motor, *i.e.*, the z axis, when the optical assembly, or the electric motor beam path channel, encompass collimated space, as is the case with the

FIG. 2 embodiment, may be larger than tolerances in the x,y axis and tolerances for tilt along the x,y axis, without detrimentally effecting the transmission of the laser beam through the electric motor. Thus, preferably a centralization means, such as a centralizer, a structural member, etc., can be employed with to the optical package 214.

5 Thus, it is preferable that the motor section 210 be stiff, *i.e.*, provide very little bending. Additionally, the length of the motor section in which the optical packages and the optical assembly are associated, may be limited by the distance over which the laser beam, *e.g.*, 206a, can travel within the beam path channel 215.

**[0056]** The motor 210 has a beam path channel 215, which is contained  
10 within a beam path tube 209. The beam path tube 209 is mechanically and preferably sealing associated with the optical package 207 by attachment means 208, and with optical package 214 by attachment means 213. The beam path tube 209 may rotate, *e.g.*, move with the rotation of the rotor 220, be fixed to, with, the optical package 207 and thus not rotate, or be rotatable but not driven by, or not directly mechanically driven  
15 by the rotor 220.

**[0057]** Preferably, when using a fluid that is not transmissive or substantially not transmissive to the laser beam, or that may have contamination, *e.g.*, oils or dirt, which could foul or harm an optical element, a beam path tube may be utilized. The beam path tube isolates, or separates, the beam path channel, and thus the laser beam  
20 and associated optical elements, from such a laser incompatible fluid. Additionally, flow channels through, around, or entering after, the non-rotating components of the motor section may be used, to provide the fluid to the drill bit, or other components below the motor section, while at the same time preventing that fluid from harming, or otherwise adversely effecting the laser beam path and its associated optical elements.

**[0058]** The attachment means 213 and 208 may be any suitable attachment  
25 device for the particular configuration of beam path tube, *e.g.*, rotating, fixed, rotatable. Thus, various arrangements of seals, bearings and fittings, known to those of skill in the motor and pump arts may be employed. A further consideration, and preferably, is that the attachment means also provides for a sealing means to protect the beam path  
30 channel 215 from contamination, dirt and debris, etc, both from the fluid as well as from the attachment means itself. The faces of the optic elements of the optical packages

214, 207, as well as, the interior of the beam path channel 215 should be kept as free from dirt and debris as is possible, as the present of such material has the potential to heat up, attach to, or otherwise damage the optic when a high power laser beam is used, or propagated through them.

5           **[0059]**    The motor 210 has a rotor 220 that is hollow along its length, and has a rotor channel 216. The rotor channel 216 is in collimated space. The rotor channel 216 is in fluid communication with the upper section channel 218 and the lower section channel 221. During operation the rotor 220 is rotated, and thus rotates the lower section 212 and whatever additional section(s) are mechanically connected to the lower  
10 section, such as for example a bit. The rotor, and/or the motor section are attached to the upper and lower section by way of attachment means 211 and 223. Thus, various arrangements of seals, bearings and fittings, known to those of skill in the motor and pump arts may be employed. Further connecting, attachment and sealing means may be employed between the various sections of the EM-LBHA to meet the pressure,  
15 temperature and other down hole conditions and environments. Thus, various arrangements of seals, bearings and fittings, known to those of skill in the motor and pump arts may be employed.

**[0060]**    By way of example, in a preferred mode of operation electric power from line 204 is provided to the motor 210, which causes rotor 220 to rotate. The  
20 exterior of motor 210 does not rotate. A fluid transported down hole by the conveyance structure 202 flows from the conveyance structure through the first section channel 218, into the rotor channel 216 and into the lower section channel 221 and on to other channels, ports, nozzles, etc. for its intended use(s). The optical package 214 is mechanically fixed with the rotating portions of the lower section 212, and thus, is  
25 rotated, either directly or indirectly, by the rotor 220. For example, the optics may be attached to the lower section by way of spoke-like members extending across channel 221.

**[0061]**    The motor may also be configured such that it operates as an inside-out motor, having the exterior of motor 210 rotate and the rotor 220 remain stationary.  
30 In this situation a corresponding connection for the non-rotation rotor 220 to the conveyance structure, which also is non-rotating, may be employed.

**[0062]** In determining the size of the various channels, the flow requirements for the particular use of the EM-LBHA must be considered. These requirements should also be balanced against the laser power requirements and the size of the beam that will be launched between the non-rotating portions of the EM-LBHA, *e.g.*, 217, 207 and  
5 the rotating portions, *e.g.*, 212, 214.

**[0063]** In the embodiment shown in FIG. 2, the preferred transitional zone between rotation and non-rotating optical components of the optical assembly is the motor section 210. In this section the beams travel through free space, *i.e.*, not within a fiber or waveguide, and further the free space is collimated space. Collimated space for  
10 this transitional zone is preferred; non-collimated space, *e.g.*, defocus, use of an imaging plane, *etc.*, may be also be utilized. A fiber could also be used to convey the laser beam between the rotation and non-rotating components. In this case an optical slip ring type of assembly would be employed, in the rotating or non-rotating sections or between those sections. Examples of such an optical slip ring device for use in  
15 association with the electric motor are disclosed and taught in the following US Patent Applications: Serial No. 61/446,040 and co-filed US patent application having attorney docket no. 13938/87 (Foro s3b-1), the entire disclosures of each of which are incorporated herein by reference. Thus, and preferably, the EM-LBHA is configured such that along its length there is a section wherein an exterior section is not rotating,  
20 an interior section is rotating and the laser beam is in free space at least partially within that section.

**[0064]** Although the components of each section, and each section of the device are shown in the drawings as being completely contained within each section and/or having a clear line of demarcation, such distinctions are only for the purpose of  
25 illustration. Thus, it is contemplated that the various sections may have some overlap, that the components of the various section may extend from one section into the next, or may be located or contained entirely within the next or another section.

**[0065]** In general, the laser-mechanical drilling process, even when advancing the borehole through hard and very hard rock formations, *e.g.*, 25 ksi (thousand pounds per square inch) and greater, very low WOB, and torque may be needed. Thus, the  
30 reactive torque from the rotation of the bit may be managed by the conveyance

structure. If for some reason, it was determined that high(er) WOB and/or torque(s) were needed, or for some other reason it is viewed as undesirable to have some or all of the reactive torque managed by the conveyance structure, stabilizers and/or anchor type devices could be added to the outer sides of the motor section and/or upper  
5 section, which would engage the sides of the borehole, preventing and/or reducing the tendency of that section to rotate in response to the forces created by the bits' rotational engagement with the borehole surface.

**[0066]** Additionally, gearboxes may be used in embodiments of an EM-LBHA. The gearboxes may be included, as part of the motor section, or may be added to the  
10 assembly as a separate section and may include a passage for an optical fiber and or a beam path channel. In addition to the use of a gearbox multiple motor sections may be utilized. Thus, the motors may be stacked, in a modular fashion one, above, or below the other. Electrical power and the high power laser optics may be feed through the central hollow shafts if the stack of motors, for example. Additionally, an "inside out",  
15 e.g., the outside of the motor rotates and the inside hollow shaft remains stationary, motors may be used, in conjunction with a traditional motor. In this manner creating a stack of alternating conventional and inside out motor sections, which a fiber and/or free space beam channel going through the stack.

**[0067]** Further, although use with a line structure, or other continuous type of  
20 tube is preferred as the conveyance structure, the motor sections and/or the EM-LBHA can be used with jointed pipe (to lower and raise the EM-LBHA and to added additional rotational force if needed) and/or with casing, (e.g., for casing while drilling operations).

**[0068]** Turning to FIG. 3 there is provided an embodiment of an EM-LBHA having a tractor section. Thus, there is shown an EM-LBHA 300 having an upper  
25 section 303, a motor section 304, a first lower section, which is a tractor section 305, a second lower section 308, and a bit section 309. There is also shown a conveyance structure connector 302 and conveyance structure 301. The conveyance structure may be any suitable line structure or tubular as described above. The relationship and placement of the optical assemblies and optical paths, with respect to the motor  
30 sections is shown by phantom lines. Thus, three high power optical fibers 312, 313, 314, (one, two, three, four, five or more fibers may be utilized, with each fiber

transmitting a laser beam having about 10 kW, about 15 kW, about 20 kW and greater powers), which were contained within, or otherwise associated with, conveyance structure 301, are optically associated to an optical package 315. The laser beam path, and the laser beam when the laser is fired, travels through a beam path channel that is  
5 formed by beam path tube 316. Beam path tube 316 connects to optical package 317, which connects to a connector 319, which in turn connects to an optical fiber(s) 318. Fiber(s) 318 travel through, are contained within, tractor section 205, and then are optically associated with connector 320, which in turn is optically connected to optical package 321. The laser beam is shaped and focused to a desired and predetermined  
10 pattern by the optical package and launched from the associated optical elements, which could for example be a window, toward the surface of the borehole. In this manner the laser beam would travel from the optical package 321 through a channel within the bit, existing through a beam slit 322, which in this embodiment is framed by beam path blades 311. In this embodiment the bit would utilize PDC cutters, e.g., 310.

15 **[0069]** Tractor section 305 has external blades 306, 307 these blades are configured around the exterior of the section 305, such they engage the side wall of the borehole and when rotated in one direction, (which is also the direction of rotation for the bit to drill) they advance, drive, the EM-LBHA forward, i.e., in a direction toward the bottom of the borehole. Similarly, when the blades 306, 307 are rotated in the other  
20 direction they move the EM-LBHA back, up, or away from the bottom of the borehole.

**[0070]** In the embodiment of FIG. 3 is noted that preferably optical components, 317, 319, 318, 320, and 321 rotate with the sections 305, 308, 309. Thus, the transition for non-rotating optical components to rotating optical components takes place within the motor section 304 and at least partially within the free space of a  
25 beam path channel. Embodiments of EM-LBHA where this transition occurs at other locations are contemplated. For example, an optical fiber could be extended through the motor section 304, and the first lower section 305, where in would enter an optical slip ring type assembly, which would be associated with the rotating optics 321, in the bit section. Still further, those rotating optics 321 could be located in section 308 and  
30 the length of the channel in the bit for transmitting the laser beam through the bit increased.



**[0071]** Turning to FIGS. 6, 6A and 6B there are shown schematics of the beam paths and optical components for a bent sub in association with an EM-LBHA. A fiber 601 launches a laser beam along beam path 610a into a collimating optic 602. The laser beam exists collimating optic 602 and travels along beam path 610b, which is in collimated space and enters steering collar 620. The beam exist steering color 620 and travels along beam path 610c, which is in collimated space, and at an angle to beam path 610b, and enters optics 630 that are rotating in the bent section of the bent sub. The steering collar 620 contains a beam steering assembly that has two wedges 621 and 622. These wedges, or at least one of these wedges are movable with respect to each other. Thus, as shown in FIG. 6A, the wedges 621, 622 are positioned to provide for a straight, coaxial propagation of the laser beam along beam path 610d. As shown in FIG. 6B the wedges 620, 621 are configured to provide for an angled propagation of the laser beam, that would be utilized for example during direction drilling with a bent sub. In this manner the wedge, or wedges can be configured, positioned or adjusted to direct a collimated laser beam along a beam path that follows the shape of a bent sub or directional drilling assembly. In this manner the optical wedge(s) may be adjusted in parallel with, or in concert with, the mechanical wedges, or other mechanical means for determining the angle of the bend for the bent sub. Further, connectors, optics and fibers may be associated with the wedge assemblies to transmit the laser beam further, over greater lengths, before or after the mechanical bend in the assembly.

**[0072]** The following table sets forth exemplary characteristics for an EM-LBHA, and in particular exemplary features of an embodiment(s) of the motor section of an EM-LBHA.

**[0073]**

General Exemplary Performance Criteria and Characteristics

Motor Type	Permanent Magnet Synchronous motor
Motor Back-EMF	To Suit Drive
Mode of operation	Continuous (Powered from a motor drive to constant speed)
Orientation	Generally vertical but investigate effect of horizontal operation (primarily on shaft life) 45 -65 from vertical
Pole Number	4
Outside Diameter	3.80" ( 96.52 mm) Maximum.

Inside Diameter of Shaft bore	Largest possible diameter subject to maximum torque; preferably about 1.125"
Active Length	Target Output = 50kW/meter.
Motor Cooling	Oil – Sealed Heat exchange to pump assembly walls (typically, liquid drilling fluid)
Thrust Load	80 kN (300kW system)
Control Mode	Sensorless
Rotation	CW and ACW
<b>Input</b>	
Configuration	3 phase motor drive
Voltage	3500V for 300kW unit
Current	100 amps
Frequency	120Hz
Supply Voltage Profile	Sinewave
dv/dt Excitation	5kV/us
Supply Cable	1500 to 2500meters
<b>Output</b>	
Ambient Temperature	176C Expected (240C maximum)
Storage Temperature	-40C to +65C
Pressure	5000psi
Corrosion Resistance	H2S and CO2
<b>Protection</b>	
Motor input	Over-current protection on drive
Stator Temperature	RTD Sensor
<b>Design Life</b>	
Service	>40,000 hours
<b>External Flow</b>	
Production	6000bpd for 300kW
	3000bpd (min) for 300kW

**[0074]** Further the motor section of the EM-LBHA may be made utilizing an ESP or down hole motor have permanent magnets made from rare earth materials. This permanent magnet motor may have its rotor shaft modified to provide a channel in the rotor, i.e., a hollow rotor, for passage of an optical fiber, or free space laser beam transmission.

**[0075]** In FIG. 4 there is provided an embodiment of a high power laser drilling workover and completion system as deployed in the field for conducting drilling operations, using a LBHA, that is powered by an electric motor. A control system as

disclosed and taught in the following US Patent Applications: Serial No. 61/446,412, and co-filed patent application attorney docket no. 13938/82 (Foro s20a), the entire disclosures of each of which are incorporated herein by reference, may be used with this system. The control system may be expanded, or networked with other control  
5 systems, to provide an integrated control network for some, or all of the components disclosed in that deployment. Thus, the laser drilling system 4000 is shown as deployed in the field in relation to the surface of the earth 4030 and a borehole 4001 in the earth 4002. There is also an electric power source 4003, e.g. a generator, electric cables 4004, 4005, a laser 4006, a chiller 4007, a laser beam transmission means, e.g.,  
10 an optical fiber, optical cable, or conveyance device 4008, a spool or reel 4009 for the conveyance device, a source of working fluid 4010, a pipe 4011 to convey the working fluid, a down hole conveyance device 4012, a rotating optical transition device 4013, a high power laser tool 4014, a support structure 4015, e.g., a derrick, mast, crane, or tower, a handler 4016 for the tool and down hole conveyance device, e.g., an injector, a  
15 diverter 4017, a BOP 4018, a system to handle waste 4019, a well head 4020, a bottom 4021 of the borehole 4001, a connector 4022.

**[0076]** In addition to the injector, gravity, pressure, fluids, differential pressure, buoyancy, a movable packer arrangement, and tractors, other motive means may be  
20 used to advance the EM-LBHA to its location of operation, such as for example to a predetermined location in a borehole, for example, the bottom of the borehole so that it may be laser-mechanically drilled to drill and advance the borehole.

**[0077]** In FIG. 5 there is provided an embodiment of a mobile high power laser beam delivery system 5100 for use with an EM-LBHA for advancing boreholes.  
25 In the embodiment there is shown a laser room 5101. The laser room 5101 houses a 60 kW source of laser energy, which may be one, two, three or more fiber lasers, a chiller (or chiller interface, so that the larger heat exchanger and management section of the chiller unit can be located outside of the laser room either), a source of electrical power 5102, and a laser system controller, which is preferably capable of being  
30 integrated with a control system for the EM-LBHA. One, two or several, high power fiber(s) 5104 leaves the laser room 5101 and enters an electrical slip ring/optical slip

ring assembly 5103, (for the purposes of illustration both the high power optical fiber(s) 5104 and the electrical power line 5110 are shown going into the same side of the spool 5105; it is noted that the fiber and the electrical line could connect on different or opposites sides of the spool). There is also shown an electrical line to power the lasers 5 5109. (It being understood that a separate generator, not on the truck may be employed, and in some configurations may be preferable to reduce or eliminate vibration, noise, and to reduce the overall foot print or area of the laser unit 5100.) The conveyance structure 5106, e.g. a composite tube having electrical lines and optical fibers built into its wall is wound around spool 5105. Within the electrical/optical slip ring 10 the laser beam is transmitted from a non-rotating optical fiber to the rotating optical fiber that is contained within the conveyance device 5106 that is wrapped around spool 5105. Similarly, the electricity from electric power line 5110 is transferred by the electrical slip ring to the electric power lines in conveyance device 5106.

**[0078]** The conveyance device 5106 is associated with injector 5111 for 15 advancing and retrieving the conveyance device, which injector is associated with a handling device 5107. Within the injector 5111 there is a path of travel 5112 that has a minimum radius of curvature when the conveyance device 5106 is run through the injector 5111. This minimum radius should be such as to reduce or eliminate bending losses to the laser beam energy. When determining the size of the minimum radius, the 20 spool, or other conveyance device handling devices care should be taken to avoid unnecessary bending losses to the optical fiber associated with the conveyance device.

**[0079]** The conveyance device should have at least one high power optical fiber, may have an electric power source for the electric motor and may have additional fibers, as well as, other conduits, cables etc. for providing and receiving material, data, 25 instructions to and from the electric motor bottom hole assembly, optics and/or bit. Although this system is shown as truck mounted, it is recognized the system could be mounded on or in other mobile or moveable platforms, such as a skid, a shipping container, a boat, a barge, a rail car, a drilling rig, a work boat, a work over rig, a work over truck, a drill ship, or it could be permanently installed at a location.

30 **[0080]** In general, and by way of example a laser room may contain a high power beam switch, a high power laser source (which could be a number of lasers, a

single laser, or laser modules, collectively having at least about 5 kW, 10 kW, 20 kW, 30 kW 40 kW, 70 kW or more power), a chiller or a connection to a chiller assembly for the laser unit and a control counsel that preferably is in control communication with a control system and network. Examples of control systems and networks are disclosed and taught in the following US Patent Applications: Serial No. 61/446,412, and co-filed patent application attorney docket no. 13938/82 (Foro s20a) filed contemporaneously herewith, the entire disclosures of each of which are incorporated herein by reference. The controller may also be in communication with a first spool of high power laser cable, a second spool of high power laser cable and a third spool of high power laser cable, etc. Preferably, the larger components of the chiller, such as the heat exchanger components, will be located outside of the laser room, both for space, noise and heat management purposes. In higher power systems, e.g., greater than 20 kW the use of multiple fibers and other multiple component type systems may be employed. The optical fiber in the conveyance device is then capable of being attached to a high power EM-LBHA, optics and/or bit. Electrical power can be supplied from the location where the laser room is located, from the mobile unit that transported the laser room, from separate generators, separate mobile generators, or other sources of electricity at the work site or brought to the work site. Separate or the same sources of electric for the laser and the EM-LBHA may be employed, depending upon, such factors as cost, availability power requirements, type of power needed etc.

**[0081]** When using a conveyance structure that is made from a composite material, an injector may not be required in some applications. Thus the EM-LBHA may be advanced by its own weight, the weight of drill collars, or a tractor section from a reel and retrieved by winding the composite tubing back onto the reel.

**[0082]** Further embodiments and teachings regarding high power optical fiber cable, fibers and the systems and components for delivering high power laser energy over great distances from the laser to a remote location for use by a tool are disclosed and set forth in detail in the following US Patent Applications and US Patent Application Publications: US 2010/0044106, US 2010/0044014, 2010/0044103, US 2010/0215326, US 2012/0020631 and Serial No. 13/210,581, the entire disclosures of each of which are incorporated herein by reference. These embodiments may be used in conjunction

with an EM-LBHA and electric motor laser drilling systems set forth in and contemplated by this specification.

**[0083]** One or more high power optical fibers, as well as, lower power optical fibers may be used or contained in a single cable that connects the tool to the laser system, this connecting cable could also be referred to herein as a tether, an umbilical, 5 wire line, or a line structure. The optical fibers may be very thin on the order of hundreds of  $\mu\text{m}$  (microns), *e.g.*, greater than about 100  $\mu\text{m}$ . These high power optical fibers have the capability to transmit high power laser energy having many kW of power (*e.g.*, 5kW, 10 kW, 20 kW, 50 kW or more) over many thousands of feet, *e.g.*, over 10 1,000 ft, over about 2,000 ft, over about 5,000 ft, over about 10,000 ft and greater. The high power optical fibers further provides the ability, in a single fiber, although multiple fibers may also be employed, to convey high power laser energy to the tool, convey control signals to the tool, and convey back from the tool control information and data (including video data). In this manner the high power optical fiber has the ability to 15 perform, in a single very thin, less than for example 1000  $\mu\text{m}$  diameter fiber, the functions of transmitting high power laser energy for activities to the tool, transmitting and receiving control information with the tool and transmitting from the tool data and other information (data could also be transmitted down the optical cable to the tool). As used herein the term "control information" is to be given its broadest meaning possible and would include all types of communication to and from the laser tool, system or 20 equipment.

**[0084]** The laser systems of the present invention may utilize a single high power laser, or they may have two or three high power lasers, or more. The high power laser beam, or beams, may have 10 kW, 20 kW, 40 kW, 80 kW or more power; and 25 have a wavelength in the range of from about 445 nm (nanometers) to about 2100 nm, preferably in the range of from about 800 to 1900 nm, and more preferably in the ranges of from about 1530 nm to 1600 nm, from about 1060 nm to 1080 nm, and from about 1800 nm to 1900 nm. Further, the types of laser beams and sources for providing a high power laser beam may be the devices, systems, optical fibers and beam shaping and delivery optics that are disclosed and taught in the following US Patent Applications 30 and US Patent Application Publications: Publication No. US 2010/0044106, Publication

No. US 2010/0044105, Publication No. US 2010/0044103, Publication No. US 2010/0044102, Publication No. US 2010/0215326, Publication No. 2012/0020631, Serial No. 13/210,581, and Serial No. 61/493,174, the entire disclosures of each of which are incorporated herein by reference. The high power lasers for example may be  
5 fiber lasers or semiconductor lasers having 10 kW, 20 kW, 50 kW or more power and, which emit laser beams with wavelengths preferably in about the 1064 nm range, about the 1070 nm range, about the 1360 nm range, about the 1455 nm range, about the 1550 nm range, about the 1070 nm range, about the 1083 nm range, or about the 1900 nm range (wavelengths in the range of 1900 nm may be provided by Thulium lasers).  
10 Thus, by way of example, there is contemplated the use of four, five, or six, 20 kW lasers to provide a laser beam in a bit having a power greater than about 60 kW, greater than about 70 kW, greater than about 80 kW, greater than about 90 kW and greater than about 100 kW. One laser may also be envisioned to provide these higher laser powers. By way of example, there is also contemplated the use of a 10 kW laser, the  
15 use of a 20 kW, the use of a 40 kW laser, as a laser source to provide a laser beam having a power of from about 5 kW to about 40 kW, greater than about 8 kW, greater than about 18 kW, and greater than about 38 kW at the work location, or location where the laser processing or laser activities, are to take place.

**[0085]** High powered optical cables, spools of cables, creels, and reels of  
20 cables of the type disclosed and taught in the following US Patent Applications and US Patent Application Publications: 2010/0044104, 2010/0044103, 2010/0215326, 2012/0020631, Serial No. 13/366,882, and Serial No. 13/210,581, the entire disclosures of each of which are incorporated herein by reference, may be used in conjunction with the present systems. Thus, the conveyance structure may be: a single high power  
25 optical fiber; it may be a single high power optical fiber that has shielding; it may be a single high power optical fiber that has multiple layers of shielding; it may have two, three or more high power optical fibers that are surrounded by a single protective layer, and each fiber may additionally have its own protective layer; it may contain other conduits such as a conduit to carry materials to assist a laser cutter, for example  
30 oxygen; it may have other optical or metal fiber for the transmission of data and control

information and signals; it may be any of the combinations set forth in the forgoing patents and combinations thereof.

5       **[0086]**    By way of example, in a high power laser system a controller may be in communication, via a network, cables fiber or other type of factory, marine or industrial data and control signal communication medium with the laser tool and potentially other systems at a work site. The controller may also be in communication with a first spool of high power laser cable, a second spool of high power laser cable and a third spool of high power laser cable, etc.

10       **[0087]**    The components, systems and operations provided in the various figures and embodiments set forth in this specification may be used with each other and the scope of protection afforded the present inventions should not be limited to a particular embodiment, configuration or arrangement that is set forth in a particular example or a particular embodiment in a particular Figure.

15       **[0088]**    Many other uses for the present inventions may be developed or released and thus the scope of the present inventions is not limited to the foregoing examples of uses and applications. Thus, for example, in addition to the forgoing examples and embodiments, the implementation of the present inventions may also be utilized in laser systems for hole openers, perforators, reamers, whipstocks, and other types of boring tools.

20       **[0089]**    The present inventions may be embodied in other forms than those specifically disclosed herein without departing from its spirit or essential characteristics. The described embodiments are to be considered in all respects only as illustrative and not restrictive.

25



What is claimed:

1. A high power laser electric motor assembly comprising:
  - a. a first section associated with a second section;
  - b. the second section rotationally associated with a third section;
  - 5 c. the first section comprising a means for receiving a high power laser beam, a means for collimating the laser beam, and a first fluid cavity;
  - d. the second section comprising an inner cavity and a second fluid cavity;
  - 10 e. a laser beam path extending through the inner cavity, wherein the laser beam path is in collimated space; and,
  - f. the third section comprising an optics assembly, and a third fluid cavity;
  - g. a first rotary sealing means associating the first and second
  - 15 sections;
  - h. a second rotary sealing means associating the second and the third sections;
  - i. wherein, the means for collimating the laser beam, the second section inner cavity and the third section optics assembly are in
  - 20 optical communication, and wherein the first fluid cavity, the second fluid cavity and the third fluid cavity are in fluid communication.
2. The assembly of claim 1, wherein the second section comprises an electric motor.
3. The assembly of claim 2, wherein the electric motor comprises a hollow rotor
- 25 defining the inner cavity.
4. The assembly of claim 1, wherein the inner cavity is in fluid isolation from the second cavity.

5. The assembly of claim 1, wherein the second cavity is formed between a rotor and a stator.
6. The assembly of claim 1, wherein the inner cavity is partially defined by a beam path tube.
- 5 7. The assembly of claim 1, wherein the inner cavity is defined by a beam path tube.
8. The assembly of claim 1, wherein the means for receiving the high power laser beam is in optical communication with a high power optical laser fiber that is in optical communication with a high power laser beam source.
- 10 9. The assembly of claim 2, wherein the means for receiving the high power laser beam is in optical communication with a high power optical laser fiber that is in optical communication with a high power laser beam source.
10. The assembly of claim 3, wherein the means for receiving the high power laser beam is in optical communication with a high power optical laser fiber that is in optical communication with a high power laser beam source.
- 15 11. The assembly of claim 6, wherein the means for receiving the high power laser beam is in optical communication with a high power optical laser fiber that is in optical communication with a high power laser beam source.
12. The assembly of claim 6, wherein the means for receiving the high power laser beam is in optical communication with a conveyance structure that is in optical communication with a high power laser beam source having greater than about 10 kW of power.
- 20 13. The assembly of claim 3, wherein the means for receiving the high power laser beam is in optical communication with a conveyance structure that is in optical communication with a high power laser beam source having greater than about 10 kW of power.
- 25 14. The assembly of claim 6, wherein the means for receiving the high power laser beam is in optical communication with a conveyance structure that is in

optical communication with a high power laser beam source having greater than about 10 kW of power.

- 5 15. The assembly of claim 1, wherein the means for receiving the high power laser beam is in optical communication with a conveyance structure that is in optical communication with a high power laser beam source having greater than about 80 kW of power.
- 10 16. The assembly of claim 3, wherein the means for receiving the high power laser beam is in optical communication with a conveyance structure that is in optical communication with a high power laser beam source having greater than about 80 kW of power.
17. The assembly of claim 2, wherein the electric motor is a rare earth permanent magnet motor.
18. The assembly of claim 3, wherein the electric motor is a rare earth permanent magnet motor.
- 15 19. The assembly of claim 4, wherein the electric motor is a rare earth permanent magnet motor.
- 20 20. The assembly of claim 4, wherein the electric motor is a rare earth permanent magnet motor.
21. The assembly of claim 5, wherein the electric motor is a rare earth permanent magnet motor.
- 20 22. The assembly of claim 13, wherein the electric motor is a rare earth permanent magnet motor.
23. The assembly of claim 15, wherein the electric motor is a rare earth permanent magnet motor.
- 25 24. The assembly of claim 3, wherein the means for receiving the high power laser beam is in optical communication with a high power optical laser fiber that is in optical communication with a high power laser beam source having greater than about 20 kW of power.

25. The assembly of claim 3, wherein the means for receiving the high power laser beam is in optical communication with a high power optical laser fiber that is in optical communication with a high power laser beam source having greater than about 60 kW of power.
- 5 26. The assembly of claim 3 wherein the means for receiving the high power laser beam is in optical communication with a high power optical laser fiber that is in optical communication with a high power laser beam source, and wherein the high power laser beam source comprises a plurality of high power lasers.
- 10 27. The assembly of claim 3, wherein the means for receiving the high power laser beam is in optical communication with a high power optical laser fiber that is in optical communication with a high power laser beam source having greater than about 60 kW of power, and wherein the high power laser beam source comprises a plurality of high power lasers.
- 15 28. The assembly of claim 3, wherein the means for receiving the high power laser beam is in optical communication with a high power optical laser fiber that is in optical communication with a high power laser beam source having greater than about 80 kW of power, and wherein the high power laser beam source comprises a plurality of high power lasers.
- 20 29. The assembly of claim 1, comprising a bent sub and a means for transmitting the high power laser beam across the bent sub.
30. The assembly of claim 29, wherein the bent sub has an optical wedge assembly.
- 25 31. The assembly of claim 2, comprising a bent sub and a means for transmitting the high power laser beam across the bent sub.
32. The assembly of claim 31, wherein the bent sub has an optical wedge assembly.
33. The assembly of claim 3, comprising a bent sub and a means for transmitting the high power laser beam across the bent sub.

34. The assembly of claim 33, wherein the bent sub has an optical wedge assembly.
35. The assembly of claim 4, comprising a bent sub and a means for transmitting a high power laser beam across the bent sub.
- 5 36. The assembly of claim 35, wherein the bent sub has an optical wedge assembly.
37. The assembly of claim 5, comprising a bent sub and a means for transmitting the high power laser beam across the bent sub.
38. The assembly of claim 37, wherein the bent sub has an optical wedge assembly.
- 10 39. The assembly of claim 7, comprising a bent sub and a means for transmitting the high power laser beam across the bent sub.
40. The assembly of claim 39, wherein the bent sub has an optical wedge assembly.
- 15 41. The assembly of claim 14, comprising a bent sub and a means for transmitting the high power laser beam across the bent sub.
42. The assembly of claim 41, wherein the bent sub has an optical wedge assembly.
43. An electric motor laser bottom hole assembly drilling system comprising:
- 20 a. a high power laser source, having the capability to provide a laser beam having a power of greater than about 50 kW;
- b. an electrical power source;
- c. a conveyance structure,
- d. an electric motor bottom hole assembly;
- 25 e. the conveyance structure optically associating the laser source and the electric motor bottom hole assembly, and the conveyance

- structure electrically associating the electrical power source and the electric motor bottom hole assembly;
- f. the electric motor bottom hole assembly comprising: an electric motor having a hollow rotor, and a laser-mechanical bit; and,
- 5 g. a laser beam path extending through the hollow rotor, whereby the laser beam from the laser source is transmitted through the hollow rotor to a laser-mechanical bit.
44. The system of claim 43, wherein the laser beam path in the hollow rotor is in collimated space.
- 10 45. The system of claim 43, wherein the laser beam path in the hollow rotor is in free space.
46. The system of claim 43, comprising a bent sub having an optical wedge assembly.
47. The system of claim 43, wherein the conveyance structure comprises three  
15 high power optical fibers.
48. The system of claim 43, wherein the laser source is capable of providing a laser beam having a power of at least about 90 kW and the conveyance structure comprises five high power optical fibers.
49. The system of claim 48, wherein the conveyance structure comprises four  
20 high power optical fibers.
50. An electric motor laser bottom hole assembly drilling system comprising:
- a. a high power laser source, having the capability to provide a laser beam having a power of greater than about 50 kW;
- b. an electrical power source;
- 25 c. a conveyance structure,
- d. an electric motor bottom hole assembly;

- e. the conveyance structure optically associating the laser source and the electric motor bottom hole assembly, and the conveyance structure electrically associating the electrical power source and the electric motor bottom hole assembly;
- 5 f. the electric motor bottom hole assembly comprising: a first optical package, a second optical package, an electric motor having a hollow rotor, and a laser-mechanical bit, wherein the first optical package comprises a collimating optic;
- 10 g. a beam path tube partially within the hollow rotor and optically and sealingly associating the first optics package and the second optics package;
- h. the second optical package optically associated with the laser-mechanic bit; and,
- 15 i. a laser beam path extending through the beam path tube, whereby the laser beam from the laser source is transmitted through the beam path tube in collimated space to the second optical package and to the laser-mechanical bit.

51. A system for performing high power laser operations comprising:

- a. a high power laser source;
- 20 b. the high power laser in optical association with a high power laser fiber;
- c. the high power laser fiber in optical communication with a first optical package in an electric motor laser bottom hole assembly;
- 25 d. the first optical package in optical communication with a second optical package and defining a laser beam path between the first and second optical packages; and,

- e. the laser beam path being at least partly located within a section of the electric motor where rotation takes place upon operation of the motor.

52. The assembly of claim 1, comprising a tractor.

5 53. The assembly of claim 3, comprising a tractor.

54. The assembly of claim 5, comprising a tractor.

55. The assembly of claim 27, comprising a tractor.

56. The assembly of claim 43, comprising a tractor.

57. The system of claim 48, comprising a tractor.

10 58. The system of claim 51, comprising a tractor.

59. A method of laser-mechanical directional drilling comprising:

- a. providing an electric motor laser bottom hole assembly system to a borehole at a borehole site, the system comprising an electric motor laser bottom hole assembly and a high power laser source, the electric motor bottom hole assembly comprising a pair of optical wedges;

15

- b. lowering the laser bottom hole assembly into the borehole;

- c. configuring the optical wedges to define an angled laser beam path;

- d. delivering a high power laser beam having at least about 20 kW to the electrical motor laser bottom hole assembly, wherein the high power laser beam is transmitted through the configured optical wedges;

20

- e. wherein the angled beam path correlates with a directional drilling path and whereby the borehole is advanced along the directional drilling path.

25

60. A method of advancing a borehole comprising:

- providing a system for performing high power laser operations comprising:



- a. a high power laser source;
- b. the high power laser in optical association with a high power laser fiber;
- 5 c. the high power laser fiber in optical communication with a first optical package in an electric motor laser bottom hole assembly;
- d. the first optical package in optical communication with a second optical package and defining a laser beam path between the first and second optical packages; and,
- 10 e. the laser beam path being at least partly located within a section of the electric motor where rotation takes place upon operation of the motor; lowering the system into a borehole and rotating the electric motor while propagating a laser beam through the electric motor bottom hole assembly to thereby advance the borehole.

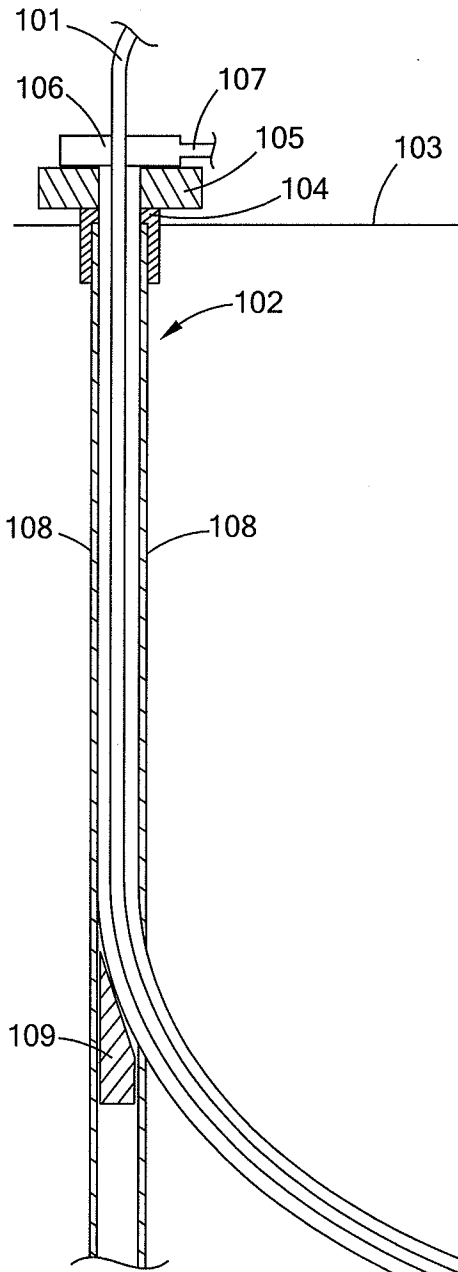

Fig. 1

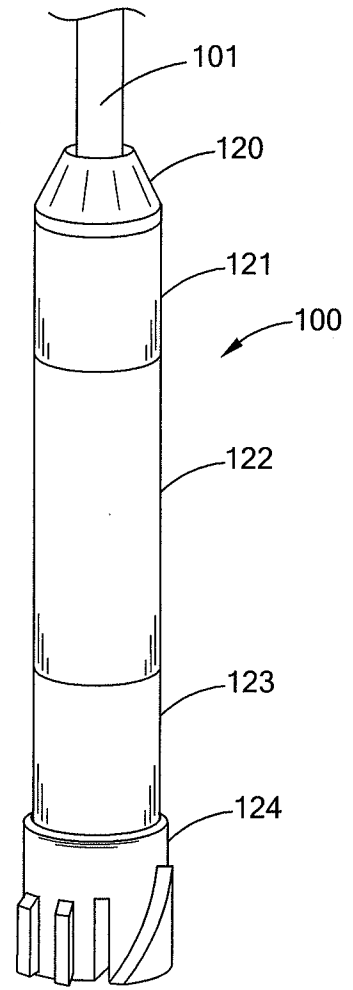

Fig. 1A

100



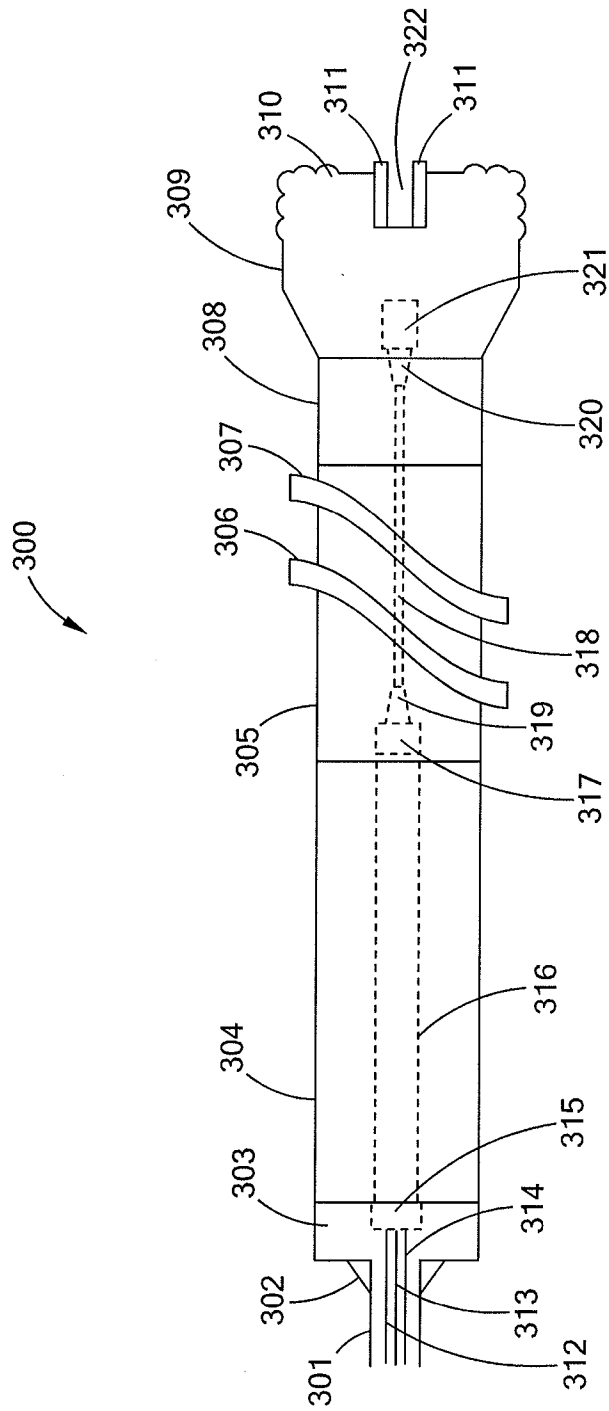

Fig. 3



5/6

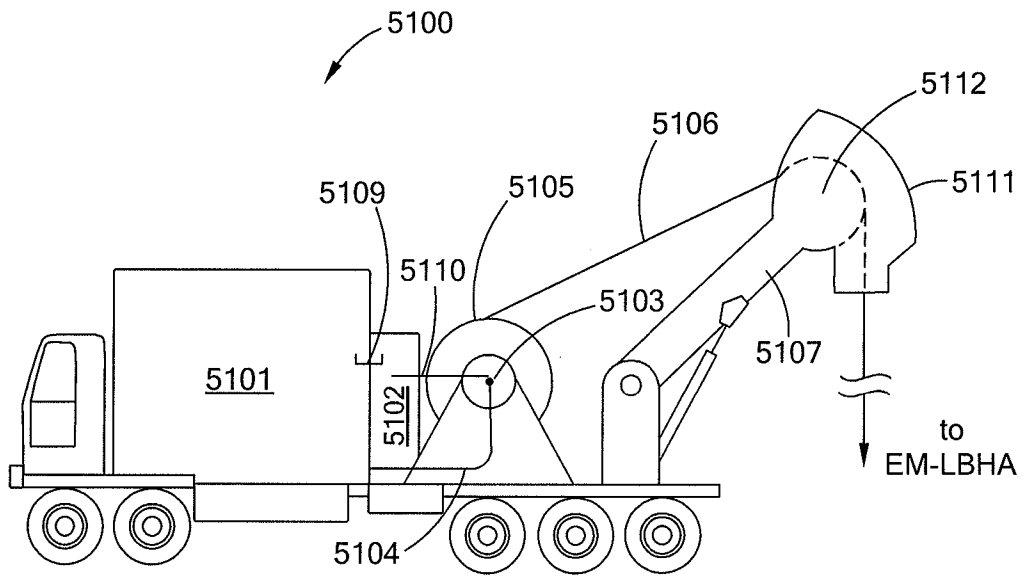

Fig. 5

6/6

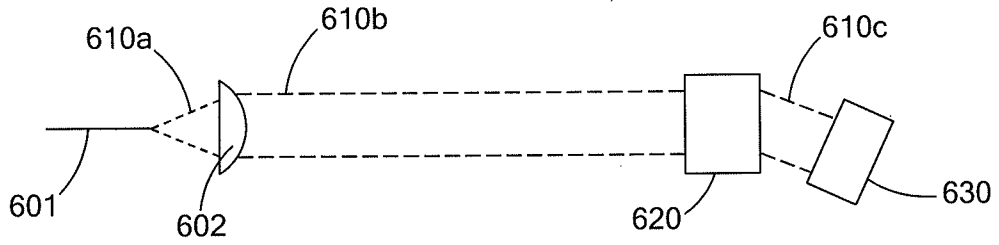

Fig. 6

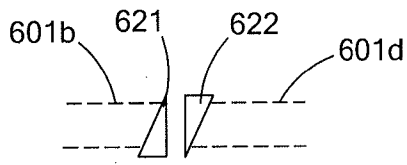

Fig. 6A

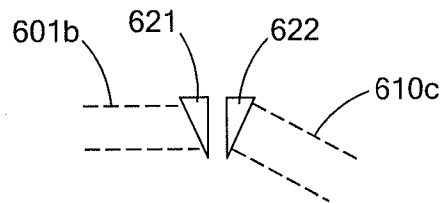

Fig. 6B

## INTERNATIONAL SEARCH REPORT

International application No.

PCT/US2012/026280

## A. CLASSIFICATION OF SUBJECT MATTER

IPC(8) - E21B 7/15 (2012.01)

USPC - 175/16

According to International Patent Classification (IPC) or to both national classification and IPC

## B. FIELDS SEARCHED

Minimum documentation searched (classification system followed by classification symbols)

IPC(8) - 166/60, 65.1, 248; 175/11, 15, 16 (2012.01)

USPC - E21B 7/14, 7/15

Documentation searched other than minimum documentation to the extent that such documents are included in the fields searched

Electronic data base consulted during the international search (name of data base and, where practicable, search terms used)

PatBase

## C. DOCUMENTS CONSIDERED TO BE RELEVANT

Category*	Citation of document, with indication, where appropriate, of the relevant passages	Relevant to claim No.
Y	US 2008/0245568 A1 (JEFFRYES) 09 October 2008 (09.10.2008) entire document	1-60
Y	US 2010/0078414 A1 (PERRY et al) 01 April 2010 (01.04.2010) entire document	1-58, 60
Y	US 2004/0206505 A1 (BATARSEH) 21 October 2004 (21.10.2004) entire document	1-42, 44, 50, 52-55
Y	US 4,090,572 A (WELCH) 23 May 1978 (23.05.1978) entire document	12-16, 22-25, 27-50, 55-57, 59

 Further documents are listed in the continuation of Box C.

\* Special categories of cited documents:

"A" document defining the general state of the art which is not considered to be of particular relevance

"E" earlier application or patent but published on or after the international filing date

"L" document which may throw doubts on priority claim(s) or which is cited to establish the publication date of another citation or other special reason (as specified)

"O" document referring to an oral disclosure, use, exhibition or other means

"P" document published prior to the international filing date but later than the priority date claimed

"T" later document published after the international filing date or priority date and not in conflict with the application but cited to understand the principle or theory underlying the invention

"X" document of particular relevance; the claimed invention cannot be considered novel or cannot be considered to involve an inventive step when the document is taken alone

"Y" document of particular relevance; the claimed invention cannot be considered to involve an inventive step when the document is combined with one or more other such documents, such combination being obvious to a person skilled in the art

"&amp;" document member of the same patent family

Date of the actual completion of the international search

16 May 2012

Date of mailing of the international search report

30 MAY 2012

Name and mailing address of the ISA/US

Mail Stop PCT, Attn: ISA/US, Commissioner for Patents  
P.O. Box 1450, Alexandria, Virginia 22313-1450

Facsimile No. 571-273-3201

Authorized officer:

Blaine R. Copenheaver

PCT Helpdesk: 571-272-4300  
PCT OSP: 571-272-7774