



US 20100211140A1

(19) **United States**

(12) **Patent Application Publication**
BARBUT et al.

(10) **Pub. No.: US 2010/0211140 A1**

(43) **Pub. Date: Aug. 19, 2010**

(54) **METHODS AND DEVICES FOR
NON-INVASIVE CEREBRAL AND SYSTEMIC
COOLING**

(60) Provisional application No. 60/681,068, filed on May 13, 2005, provisional application No. 60/717,590, filed on Sep. 16, 2005, provisional application No. 60/737,025, filed on Nov. 15, 2005.

(76) Inventors: **DENISE BARBUT**, New York, NY (US); **Allan Rozenberg**, San Diego, CA (US); **John K. Hoffman**, Poway, CA (US)

Publication Classification

(51) **Int. Cl.**
A61F 7/12 (2006.01)

(52) **U.S. Cl.** **607/105**

Correspondence Address:
O'Melveny & Myers LLP
IP&T Calendar Department LA-13-A7
400 South Hope Street
Los Angeles, CA 90071-2899 (US)

(57) **ABSTRACT**

A method for providing and adjusting cerebral cooling in response to changes in a physiological parameter. A spray having a boiling point between 38-300° C. is delivered to the surface of a patient's nasal cavities. The spray causes cooling by direct heat transfer through the nasopharynx and hematogenous cooling through the carotids and the Circle of Willis. A physiological parameter, such as cerebral temperature, changes in cerebral blood flow or brain oxygenation is monitored. The delivery rate of the spray is adjusted in response to the physiological parameter.

(21) Appl. No.: **12/703,425**

(22) Filed: **Feb. 10, 2010**

Related U.S. Application Data

(63) Continuation-in-part of application No. 11/432,285, filed on May 10, 2006.

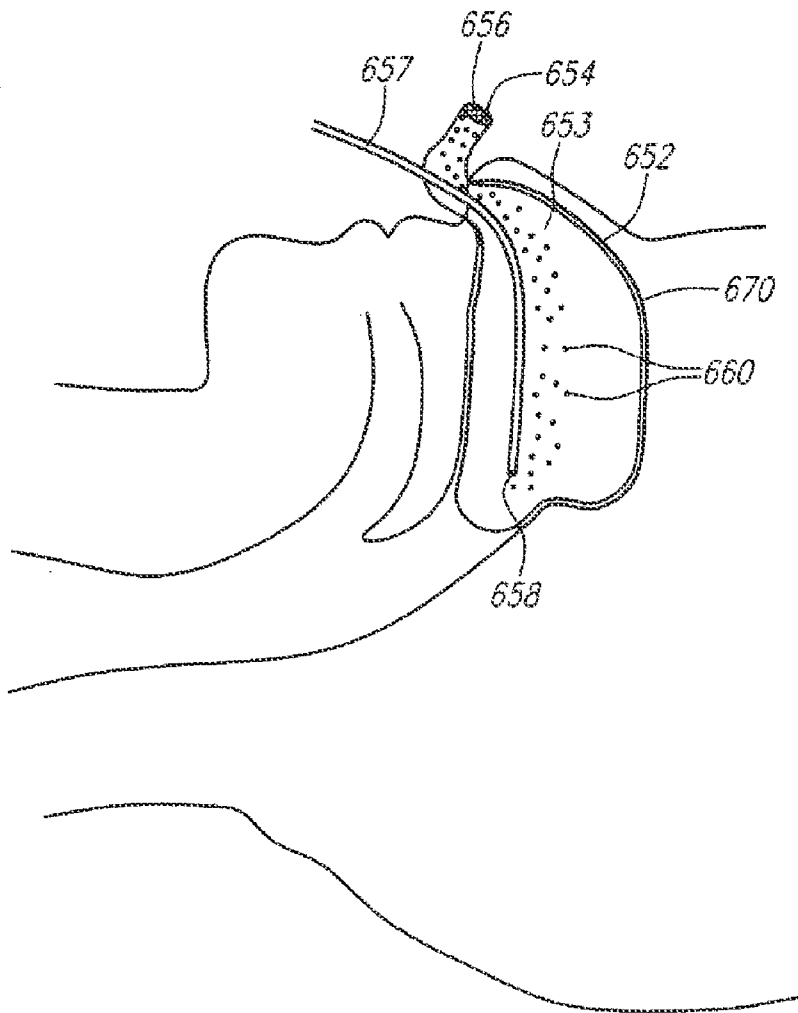

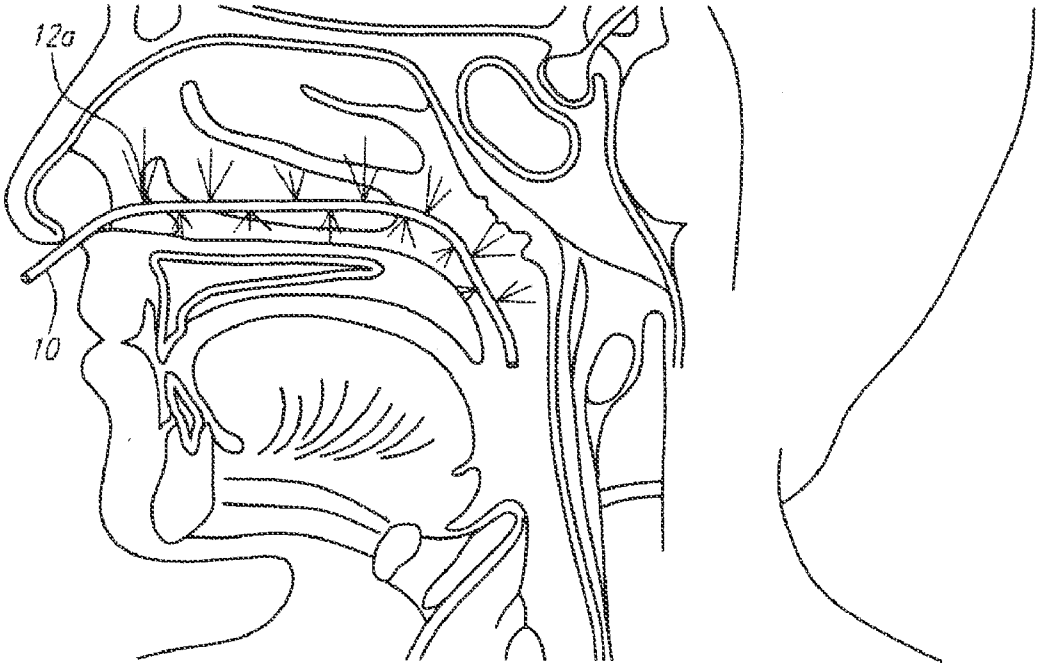

FIG. 1

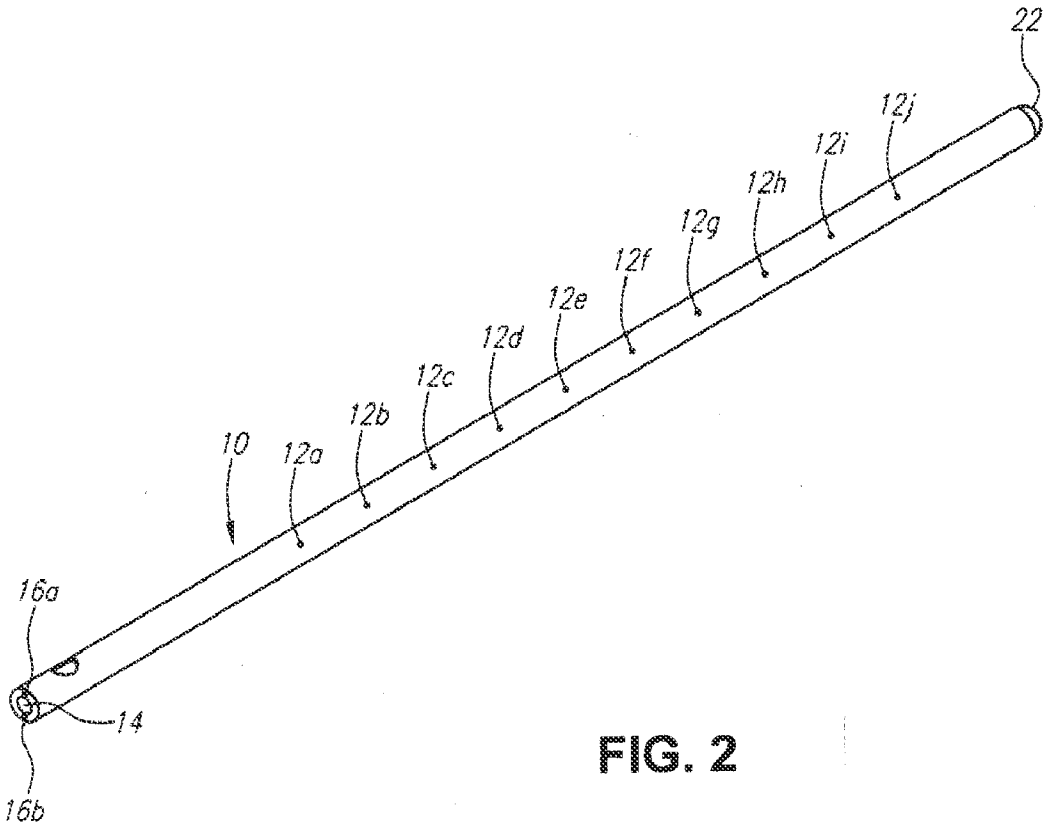

FIG. 2

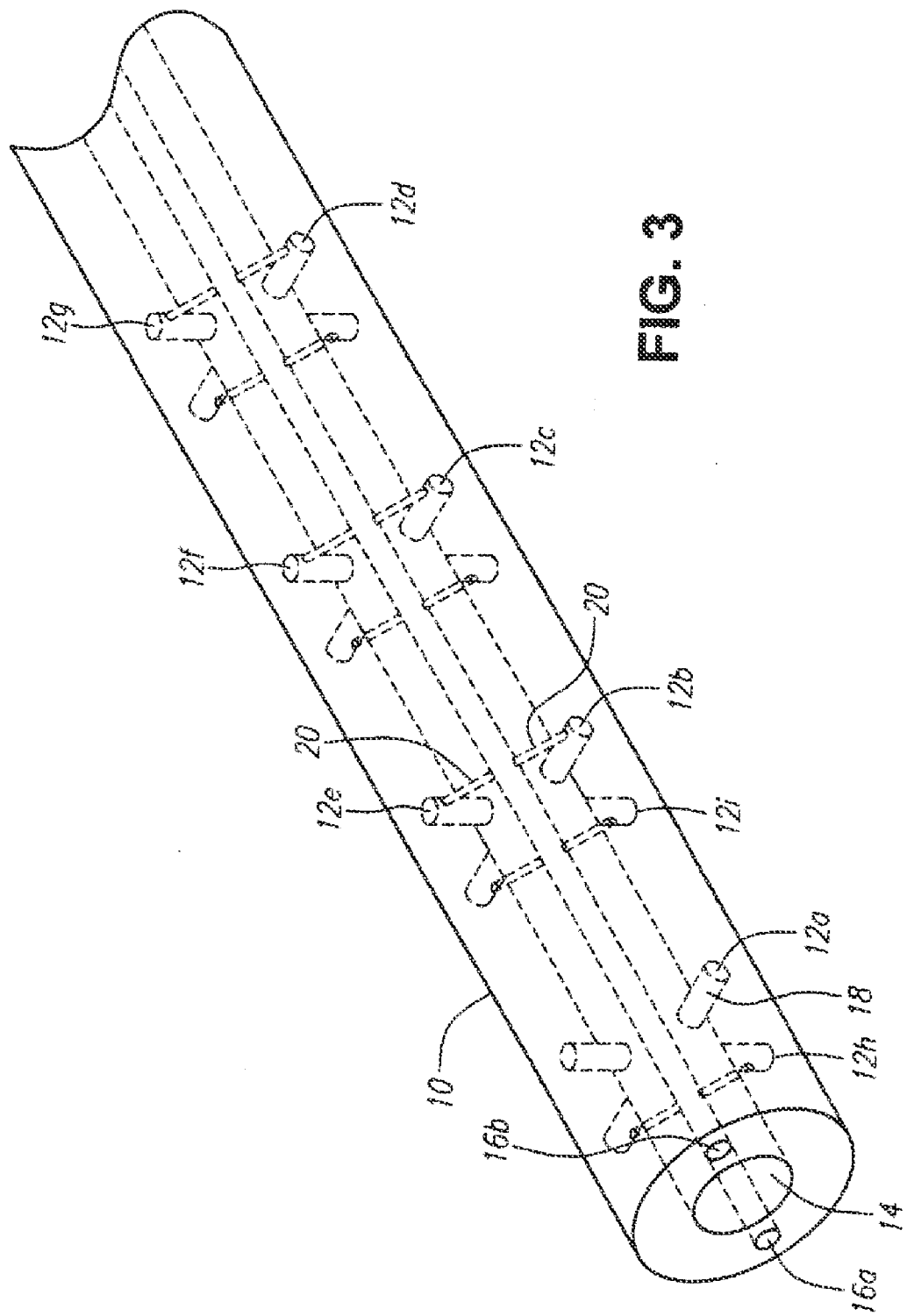

FIG. 3

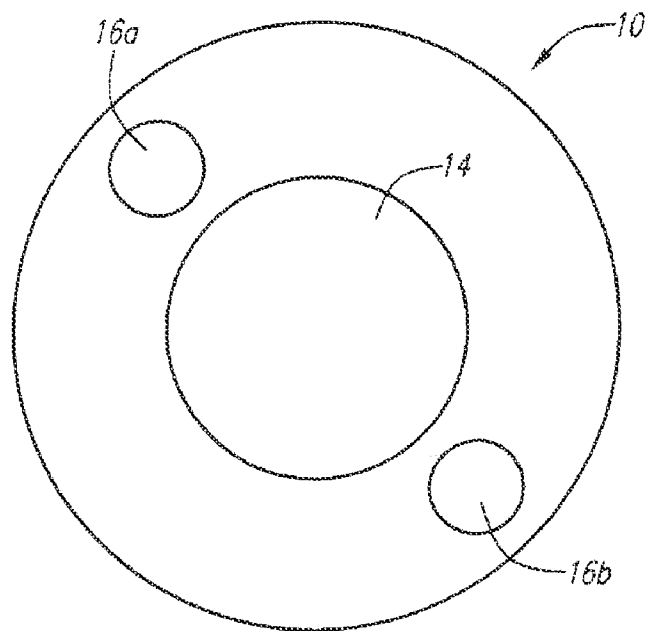

FIG. 4

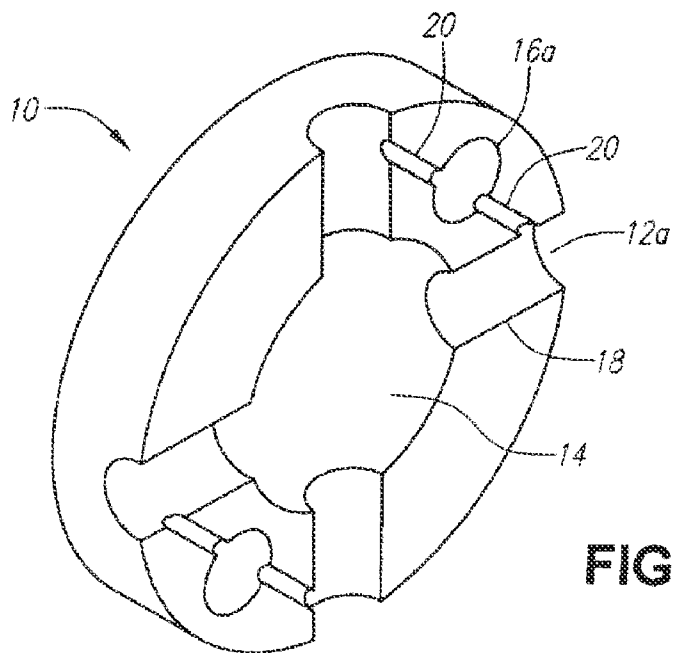

FIG. 5

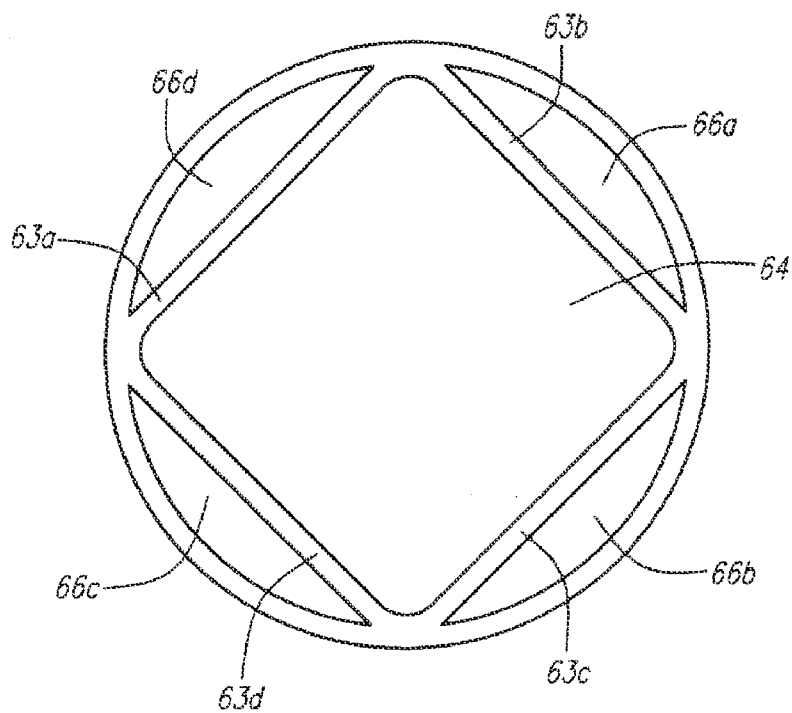

FIG. 6A

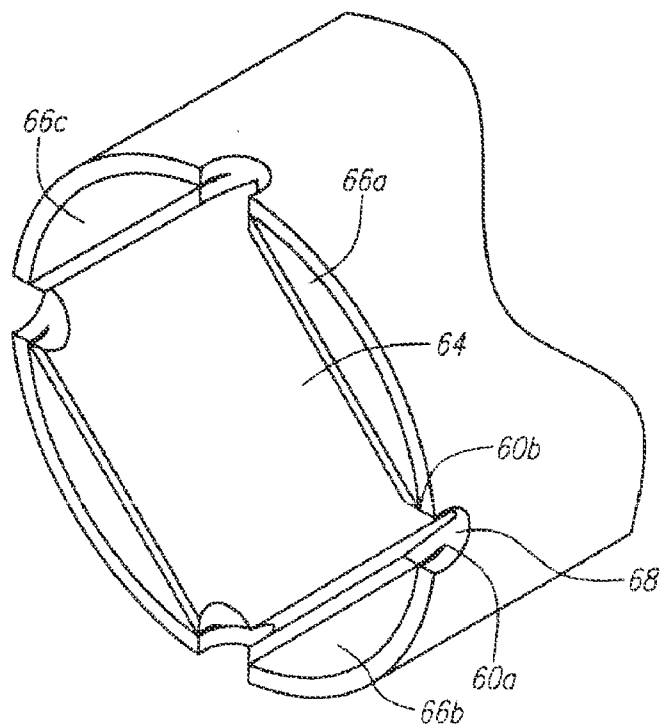

FIG. 6B

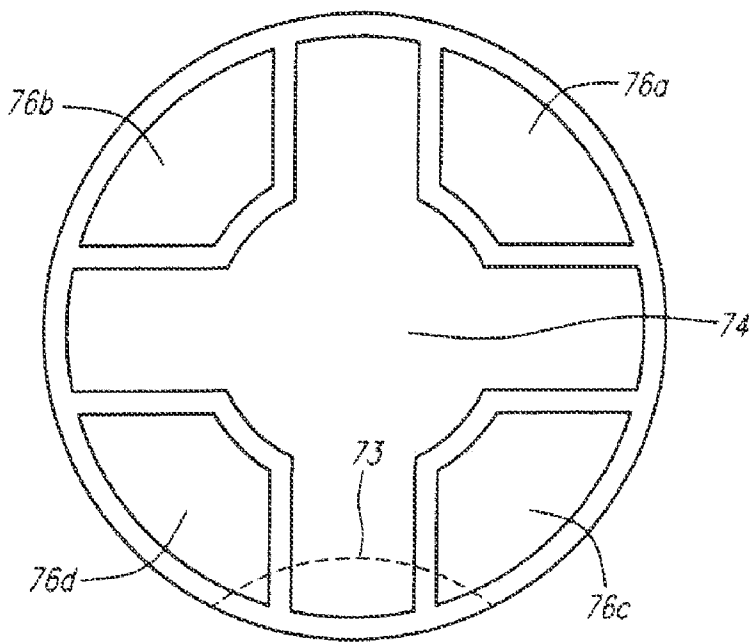

FIG. 7A

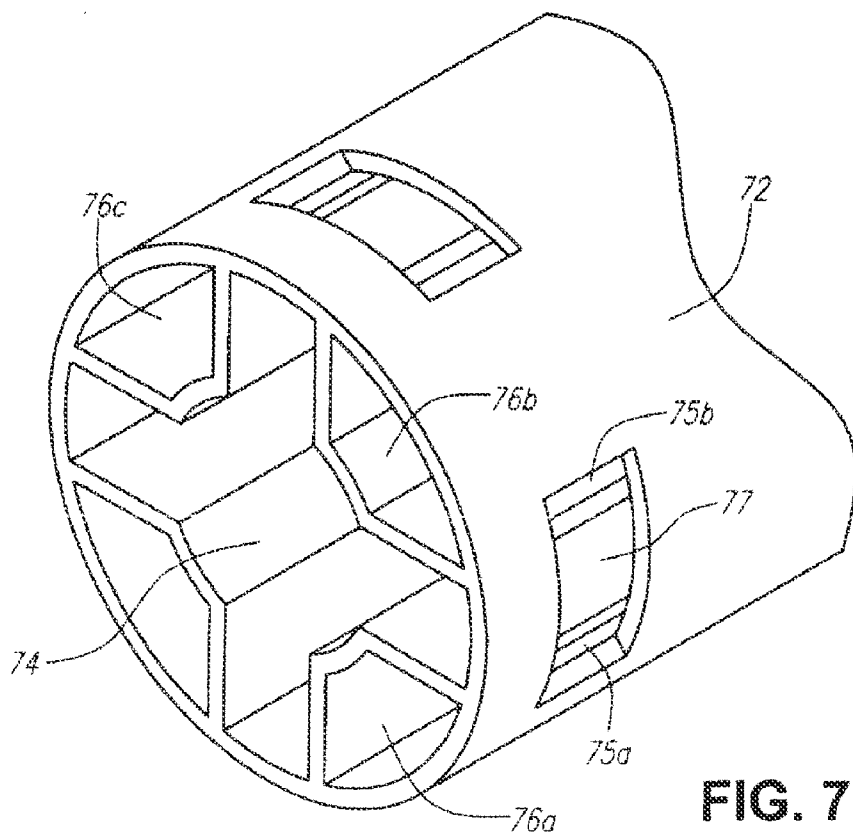

FIG. 7B

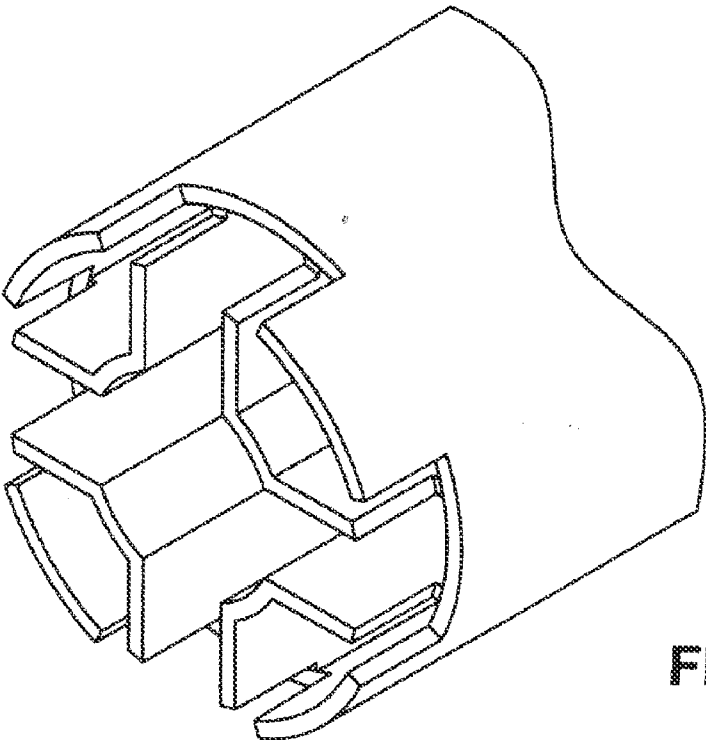

FIG. 7C

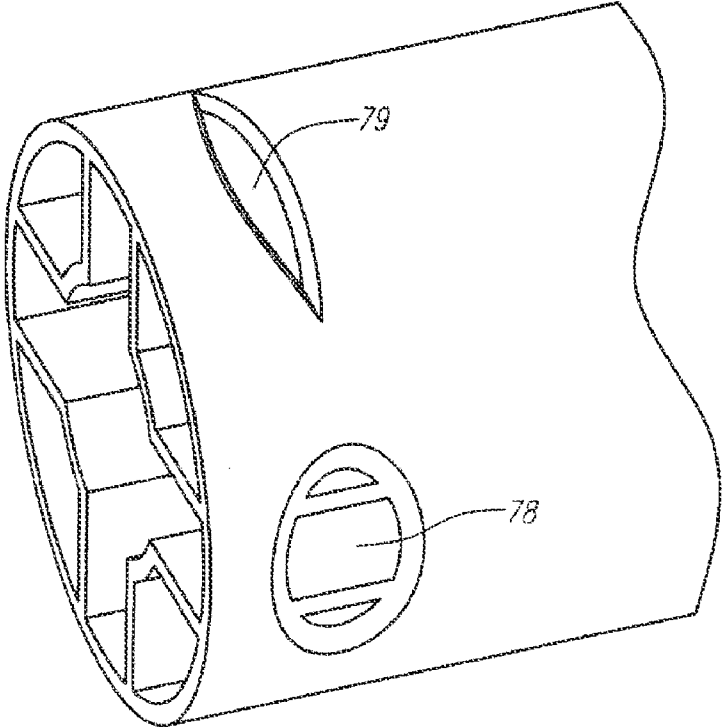

FIG. 7D

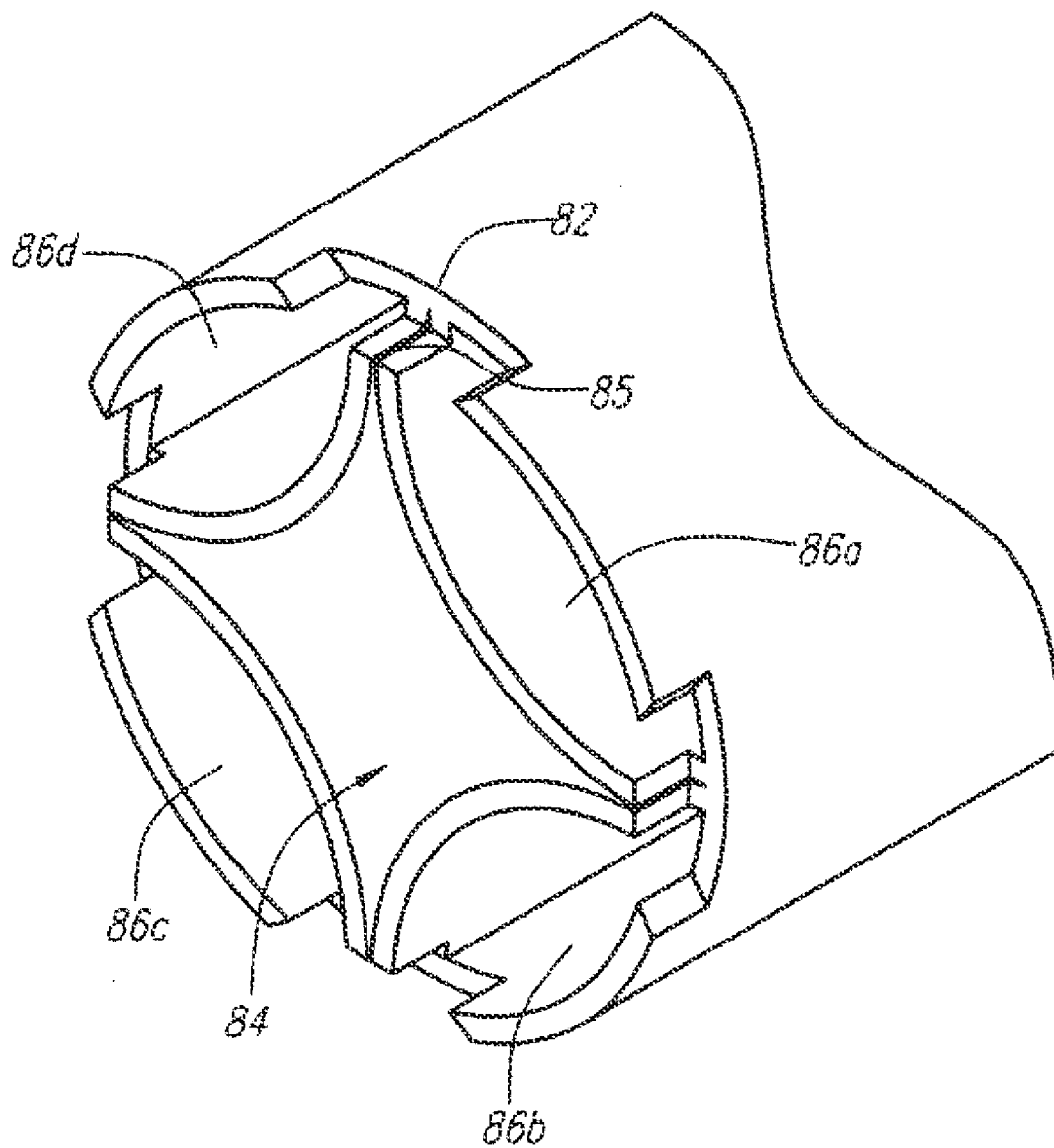

FIG. 8

Q O ₂ = 40 L/min		
Q liq (mL/min)	Temperature	Observations
10	23	No
20.1	13.2	No
30.8	7.2	No
40.3	6.5	No
50.7	7.5	Yes - slight
60.5	8.9	Yes - stream
70.1	10.1	Yes - stream
80.4	10.7	Yes - spray
90.1	11.1	Yes - spray
100	11.5	Yes - spray

Q O ₂ = 30 L/min		
Q liq (mL/min)	Temperature	Observations
10.1	23	No
20.4	16.7	No
30.3	12.7	No
40.1	9.5	Yes - slight
50.7	9.9	Yes - slight
59.8	11.1	Yes - spray
70.4	11.7	Yes - spray
80.4	12.6	Yes - spray
90	12.6	Yes - spray
100.1	13.3	Yes - spray

Q O ₂ = 50 L/min		
Q liq (mL/min)	Temperature	Observations
10	22.2	No - air
20.8	13.2	No - air
30.5	5.3	No - air
40.6	4.9	No - air
50.2	6.6	No - air
60.9	7.7	Yes- drops
69.6	8.4	Yes - drops/trickle
80.3	9.5	Yes - spray
91.1	9.8	Yes - spray
100.9	10.2	Yes - spray

FIG. 9

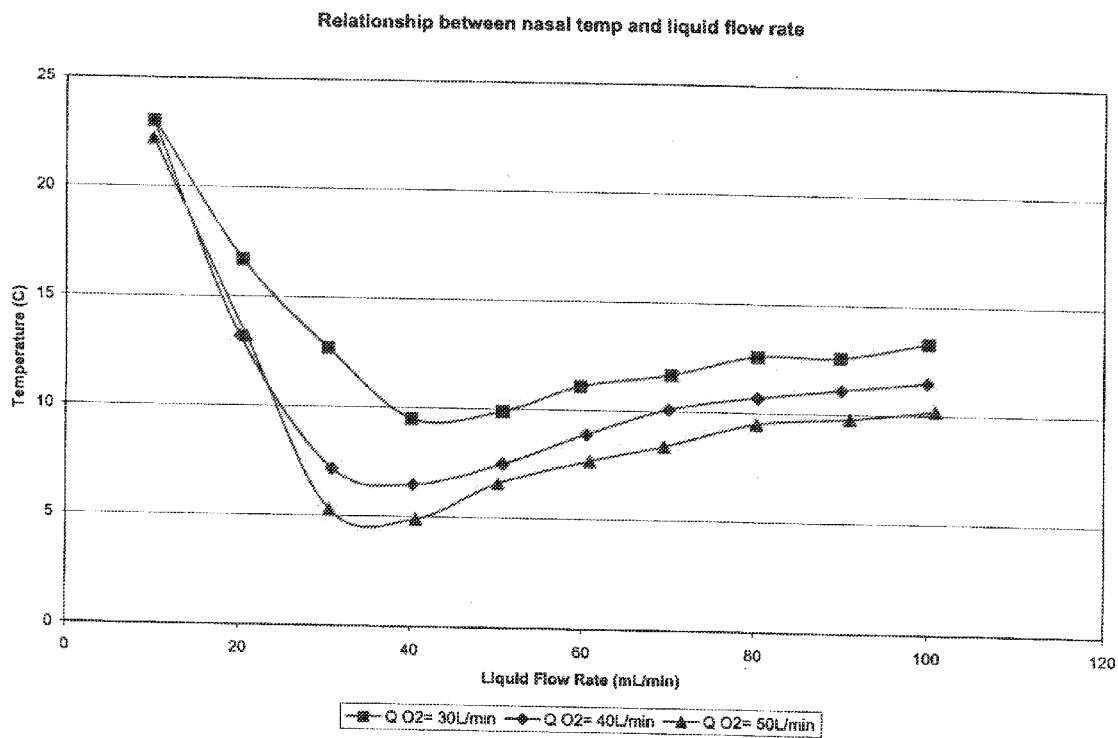

FIG. 10

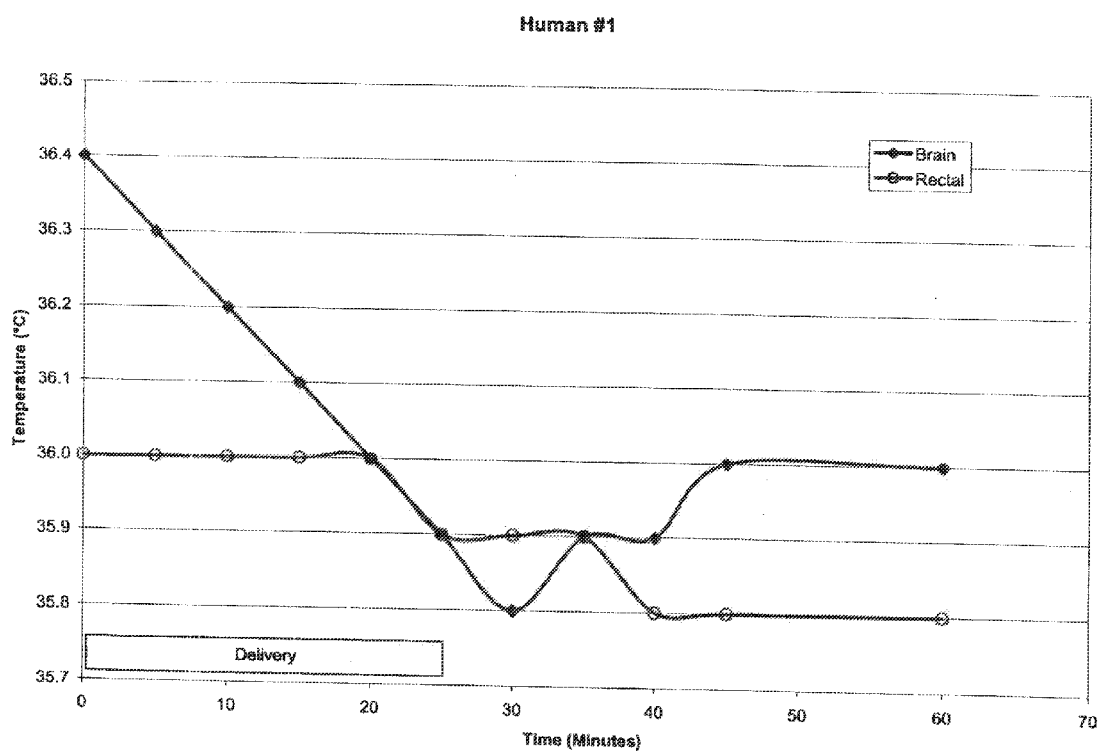

FIG. 11

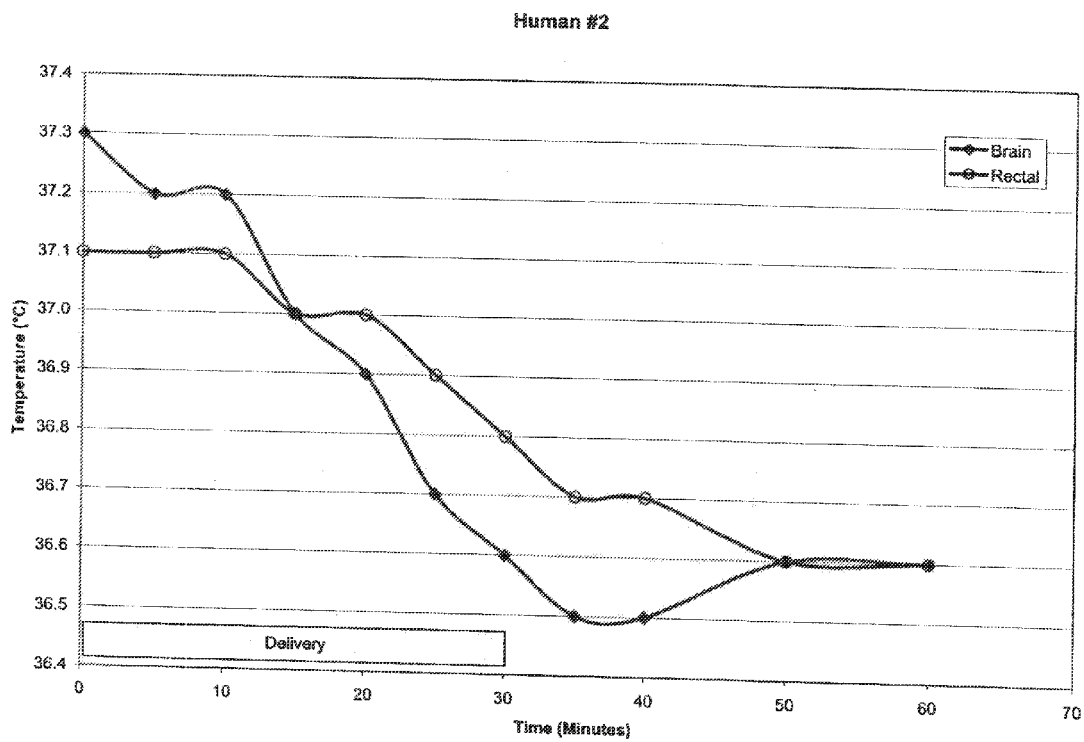

FIG. 12

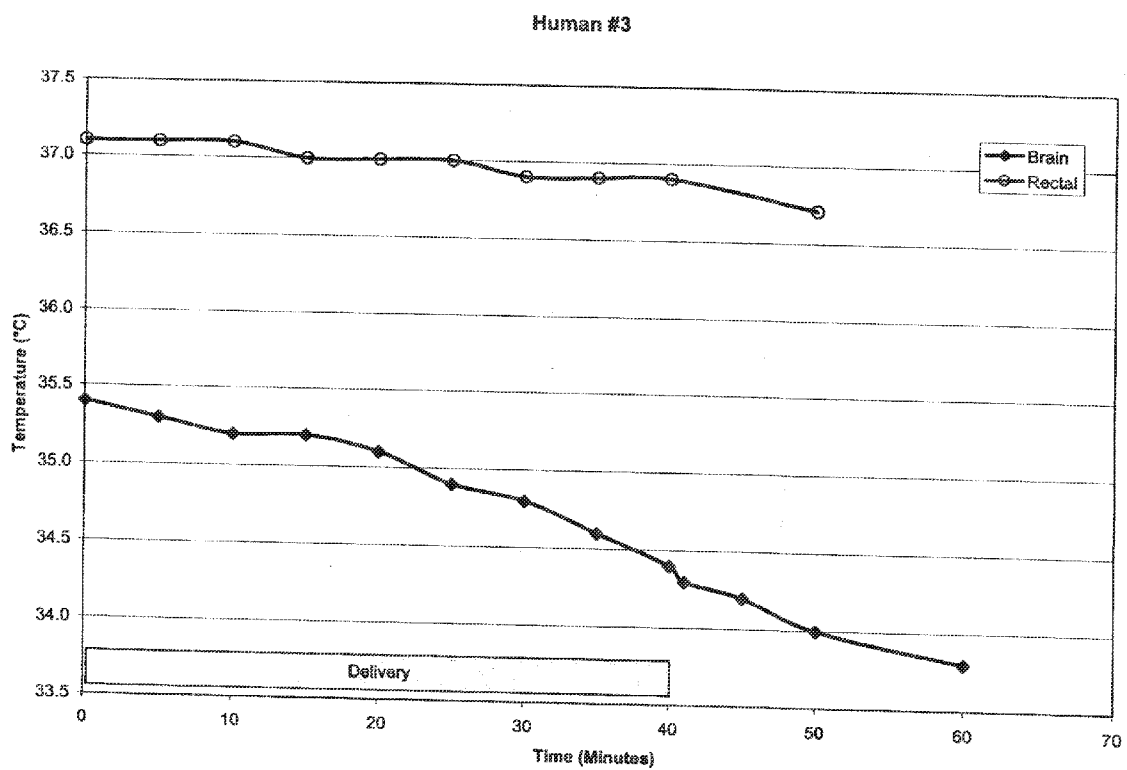

FIG. 13

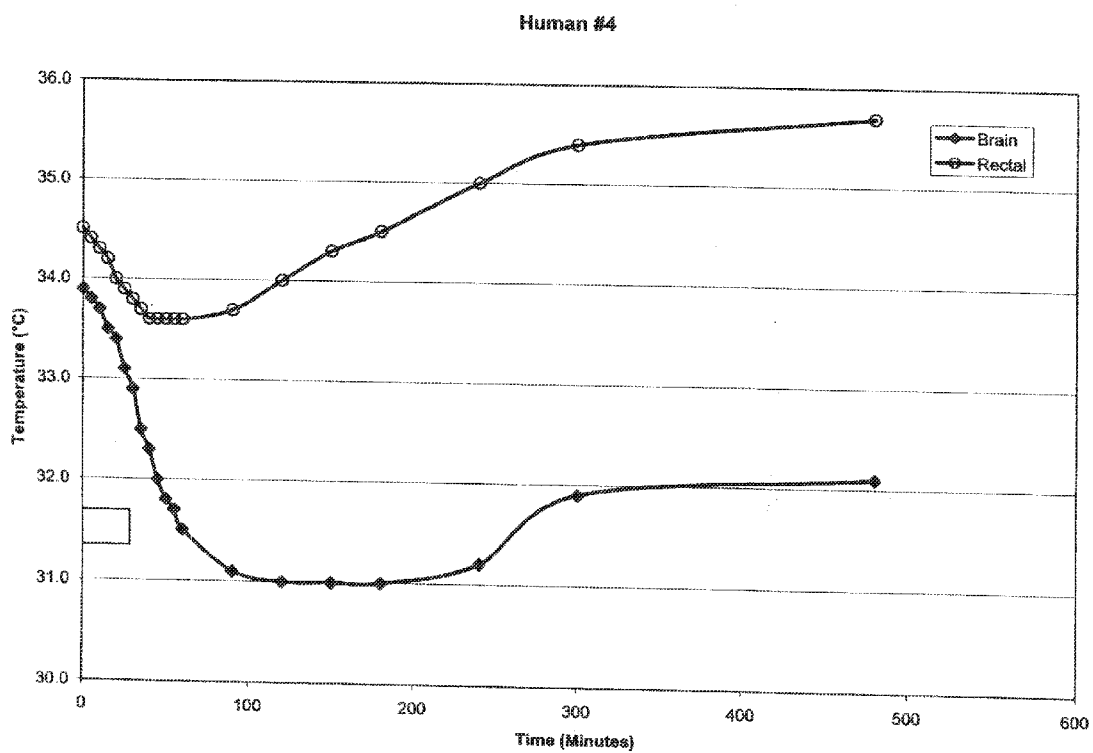

FIG. 14

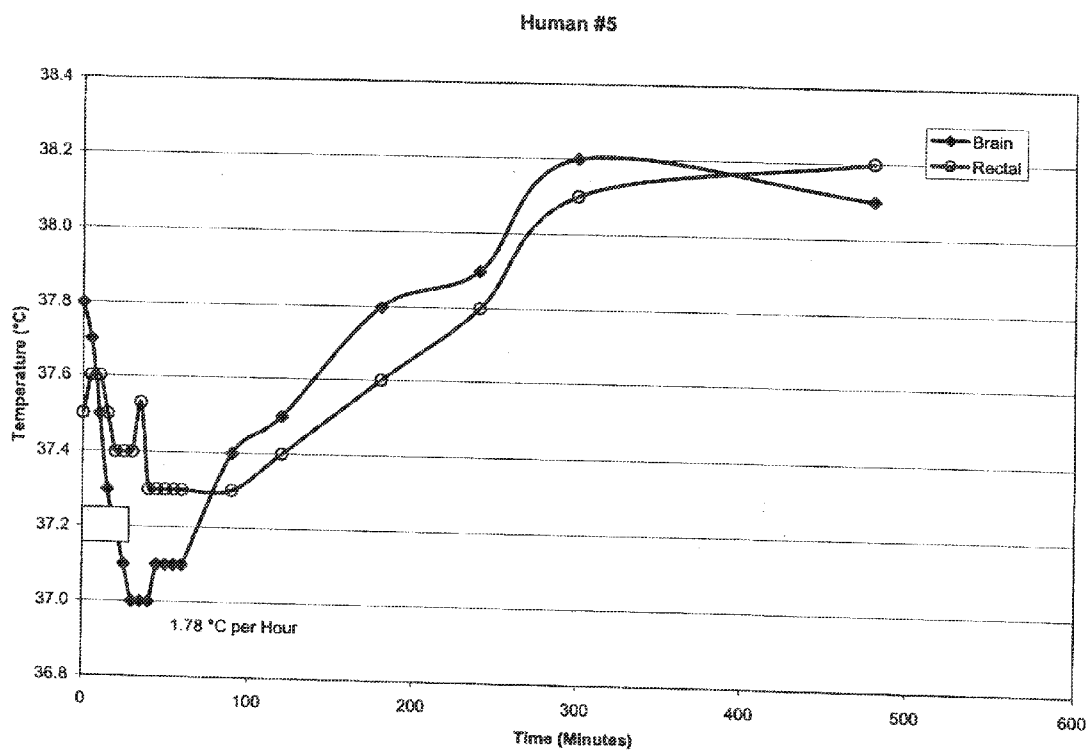

FIG. 15

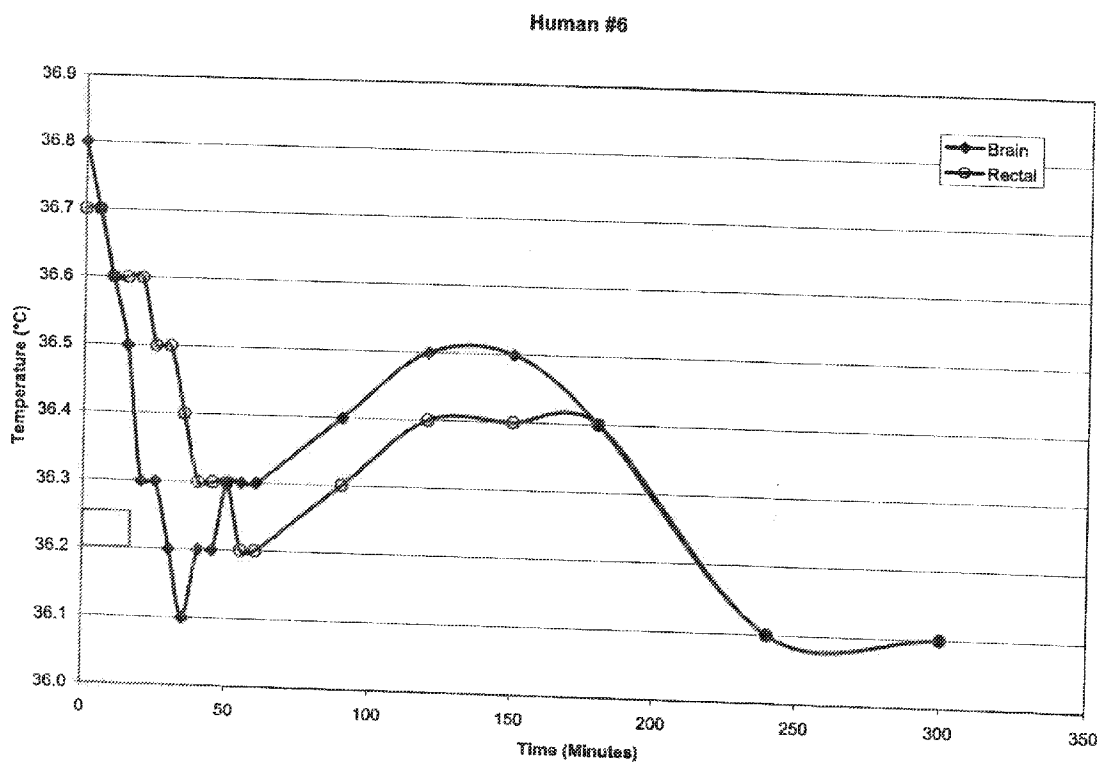

FIG. 16

Human #7

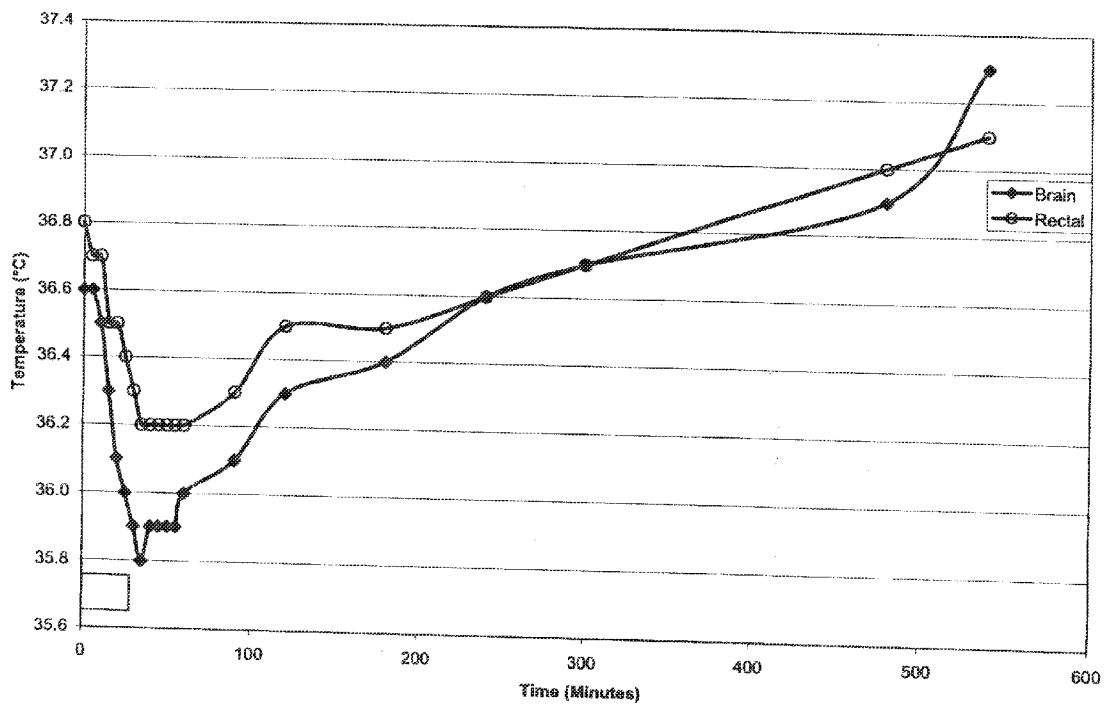

FIG. 17

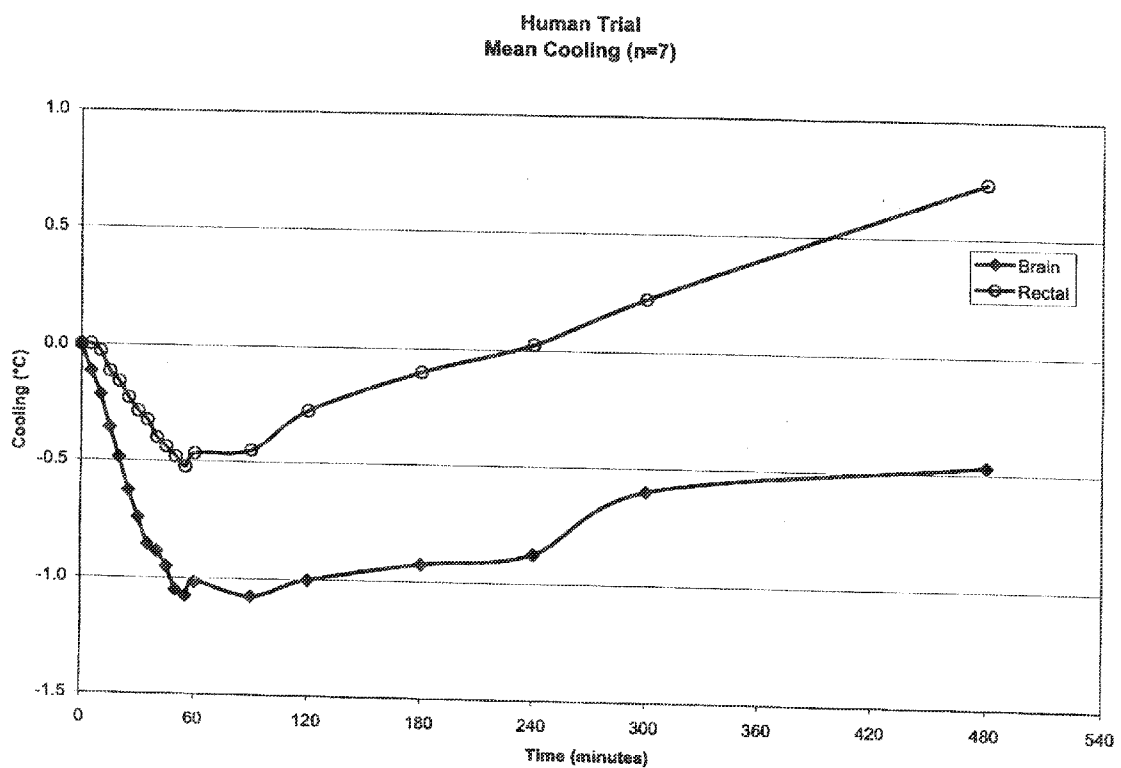

FIG. 18

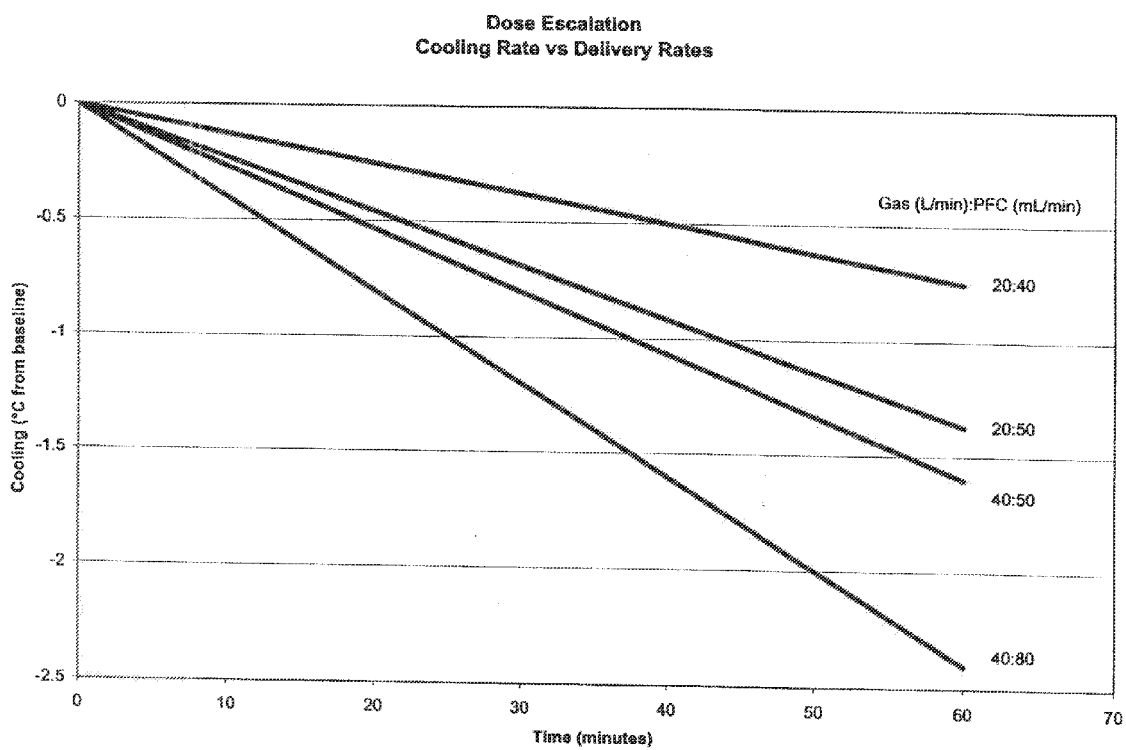

FIG. 19

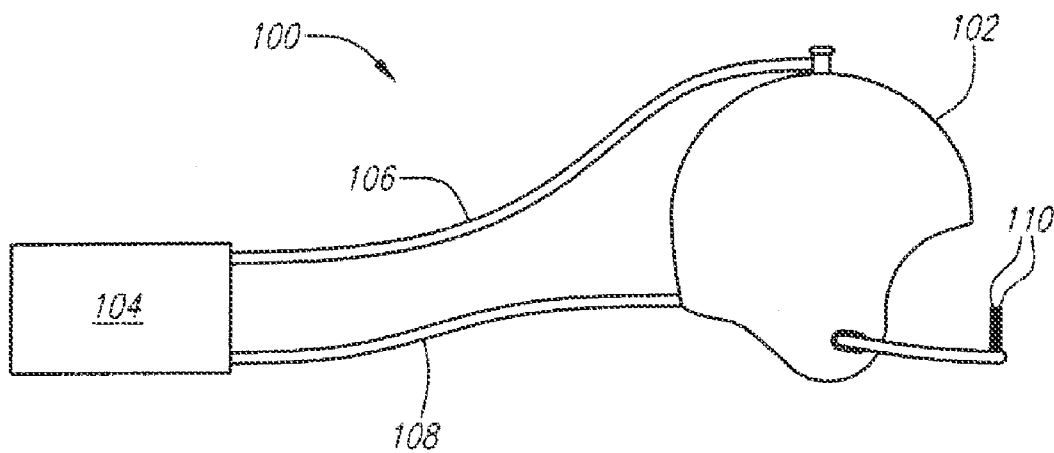

FIG. 20

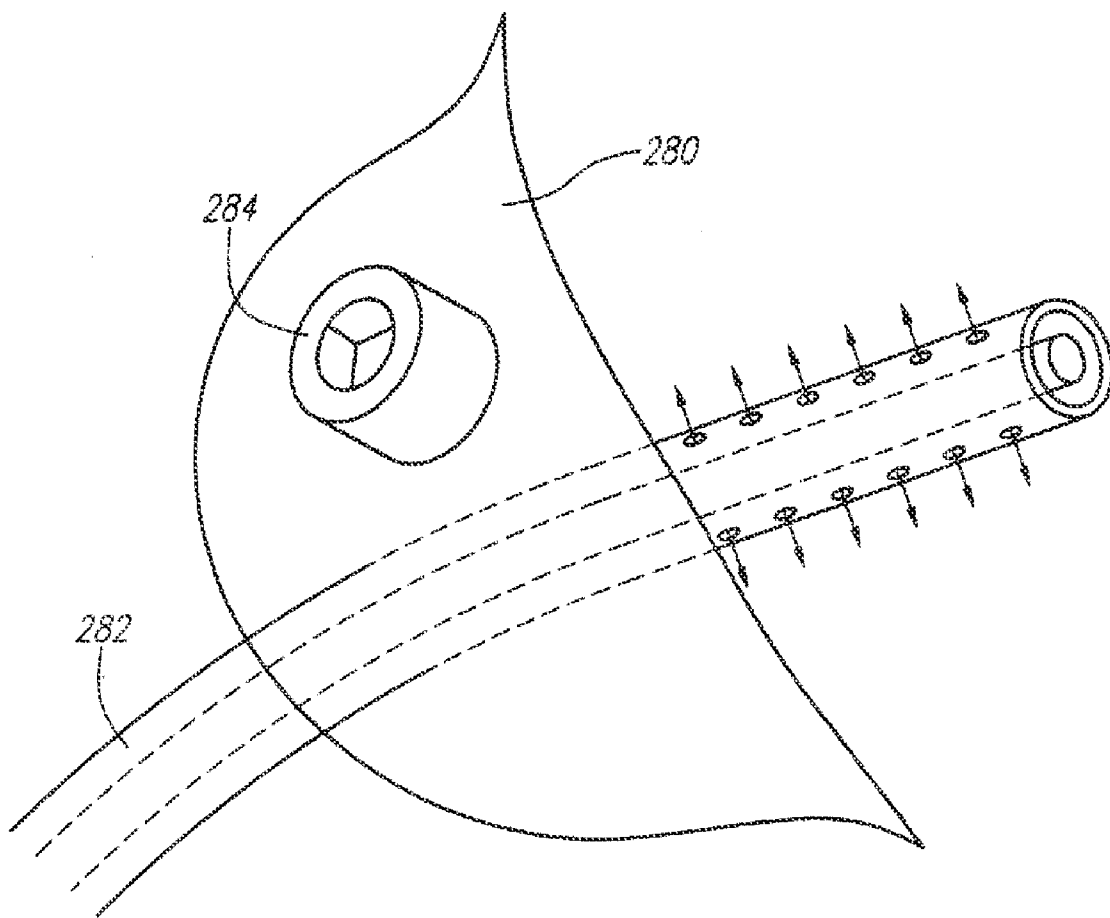

FIG. 21

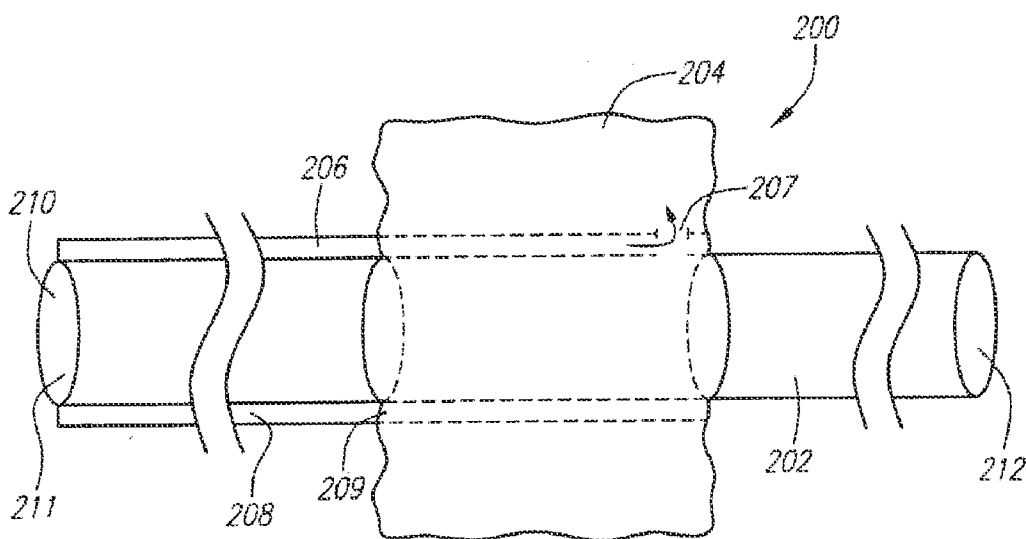

FIG. 22A

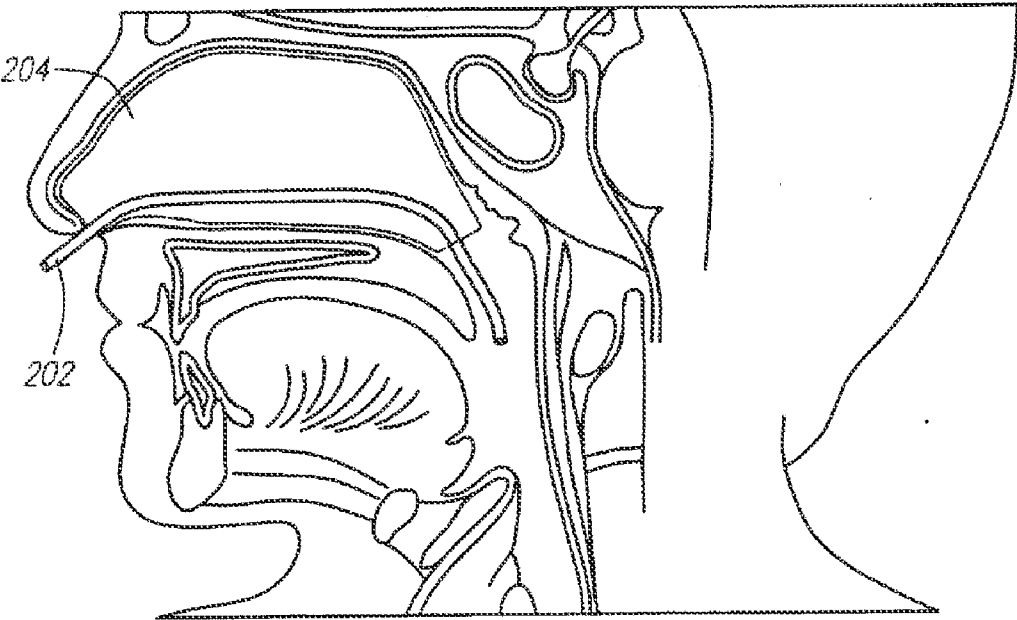

FIG. 22B

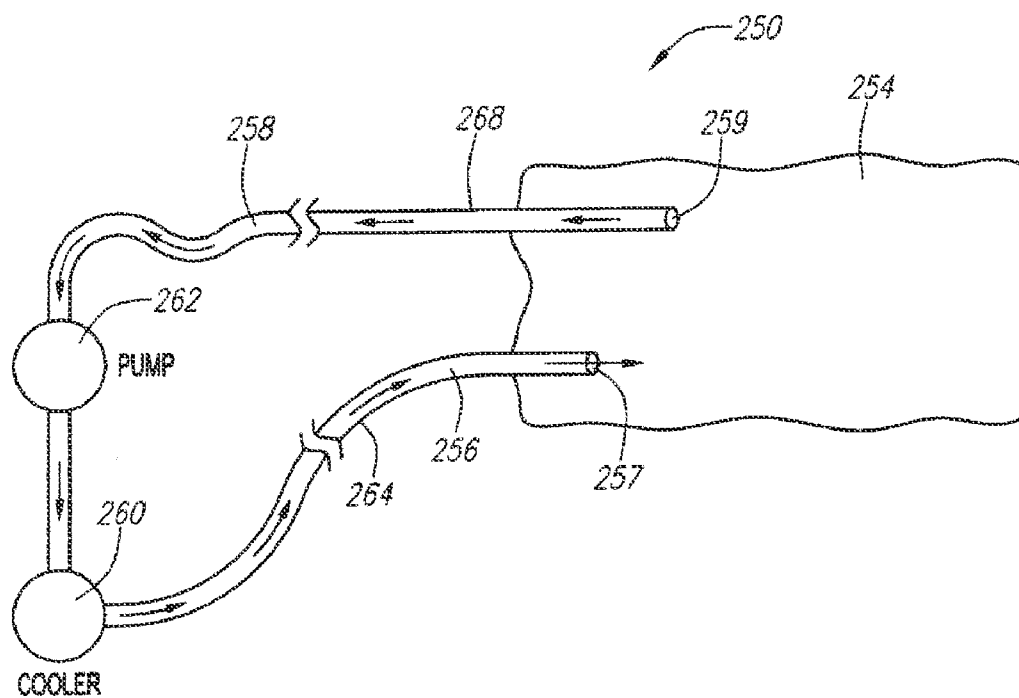

FIG. 23A

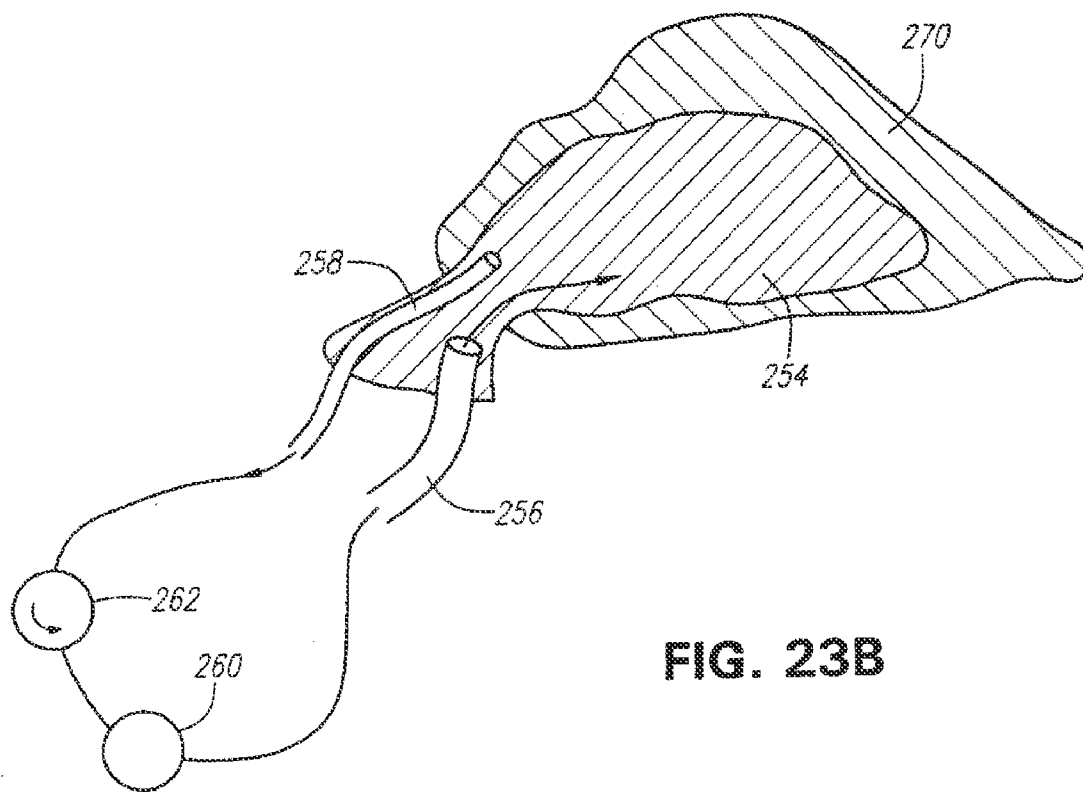

FIG. 23B

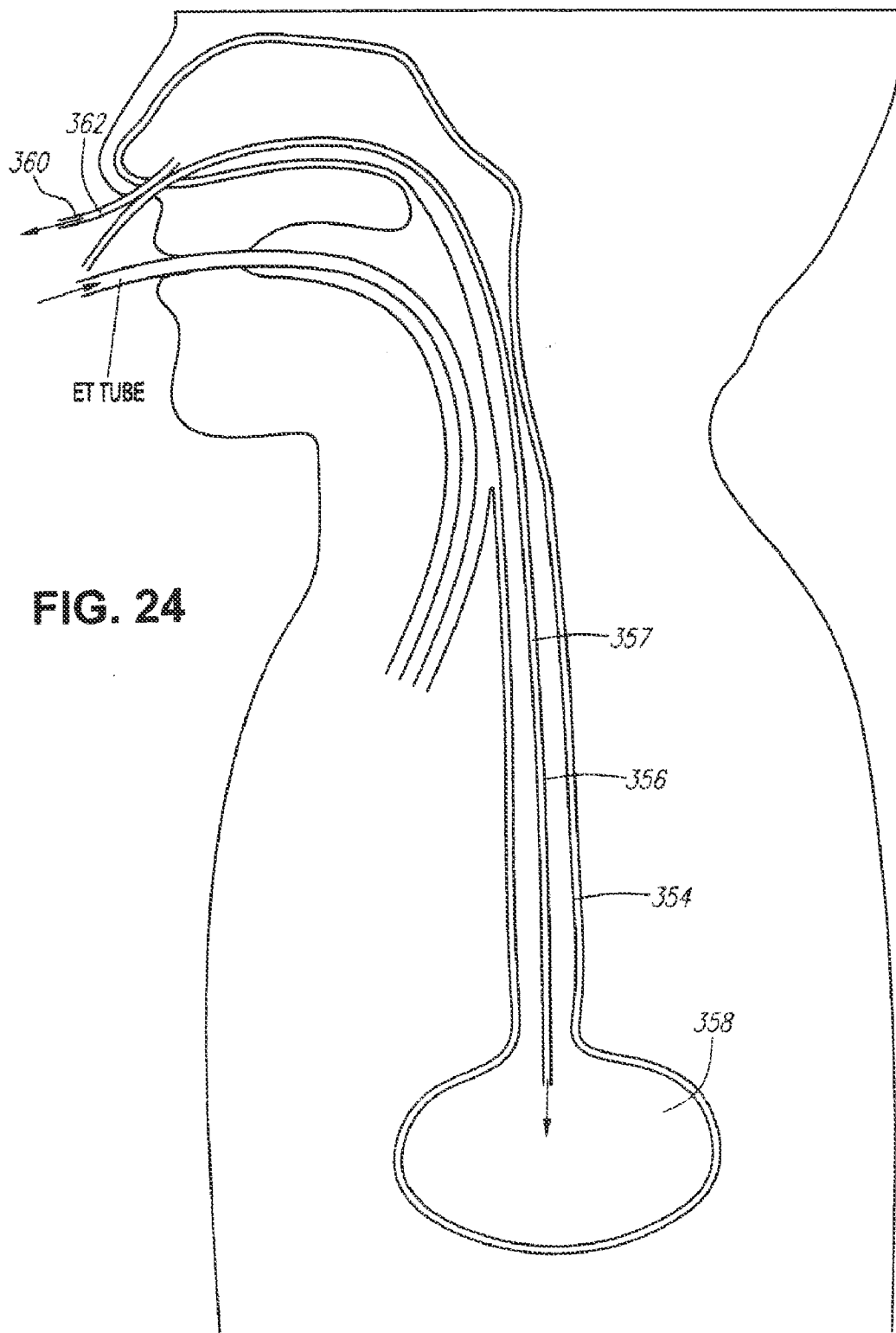

FIG. 24

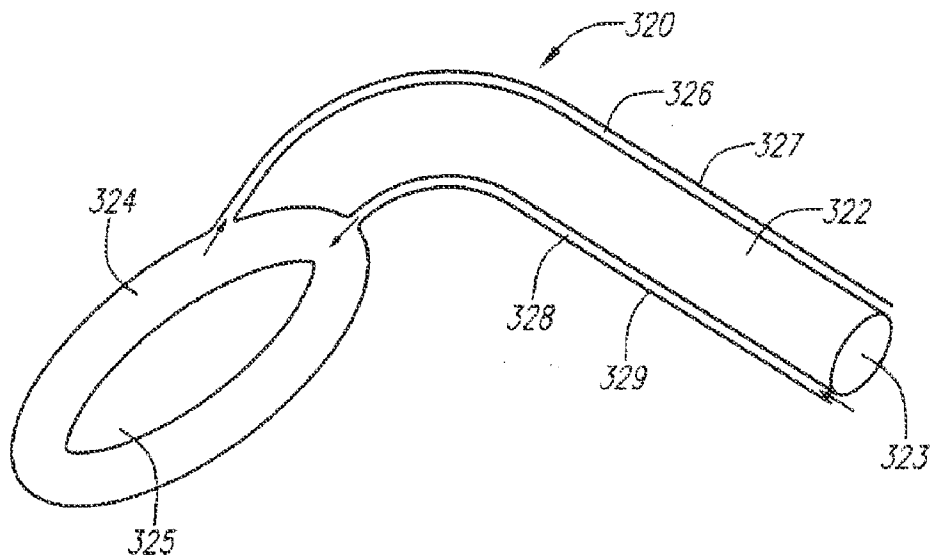

FIG. 25A

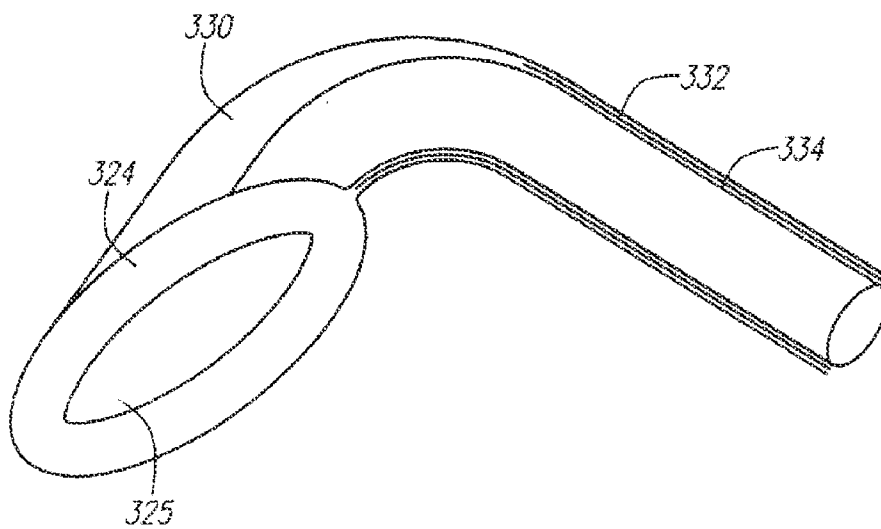

FIG. 25B

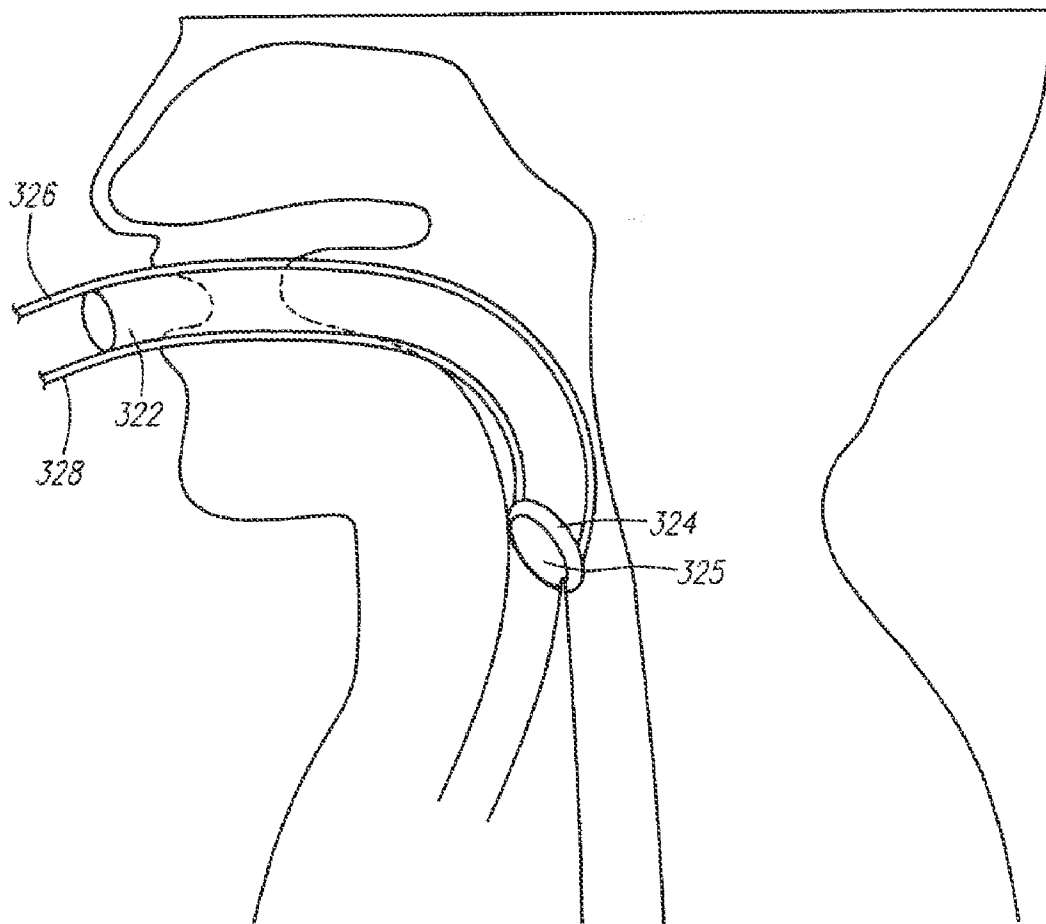

FIG. 25C

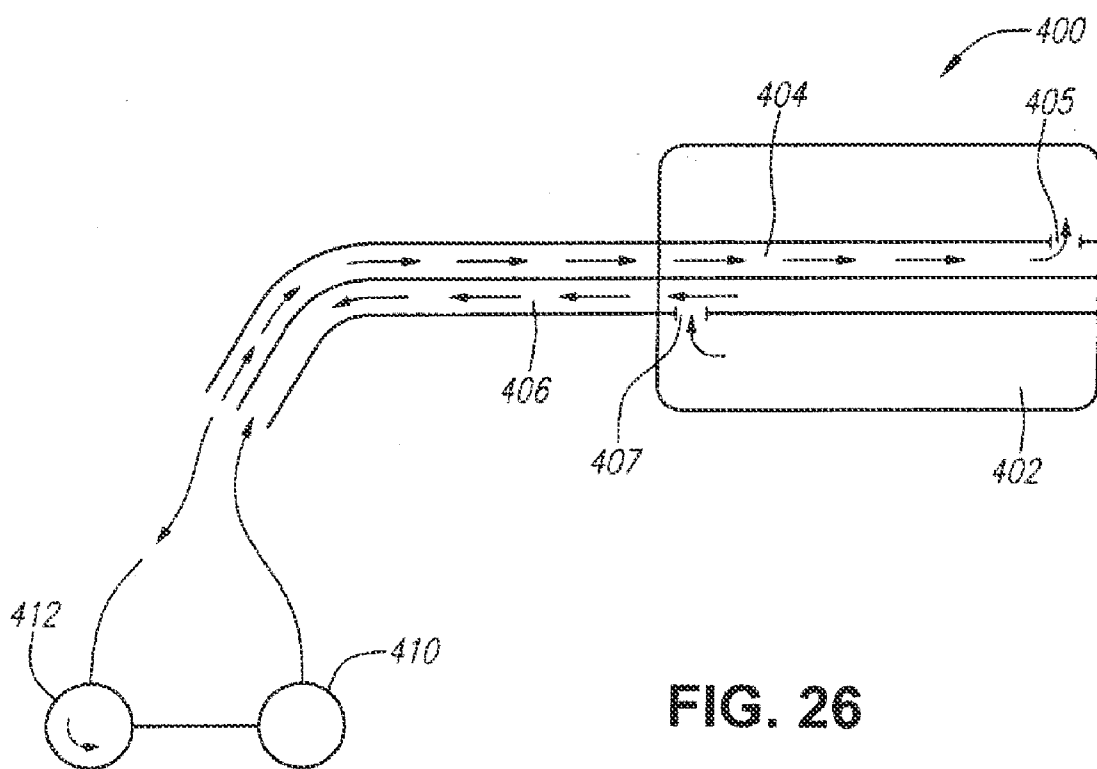

FIG. 26

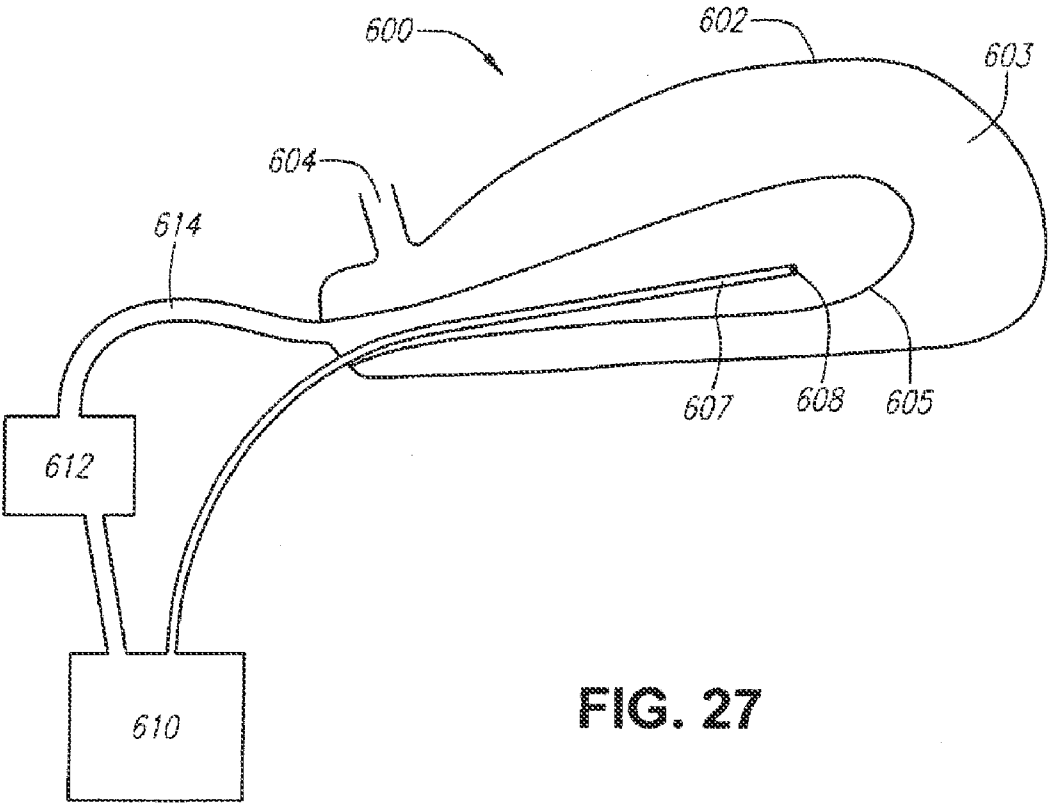
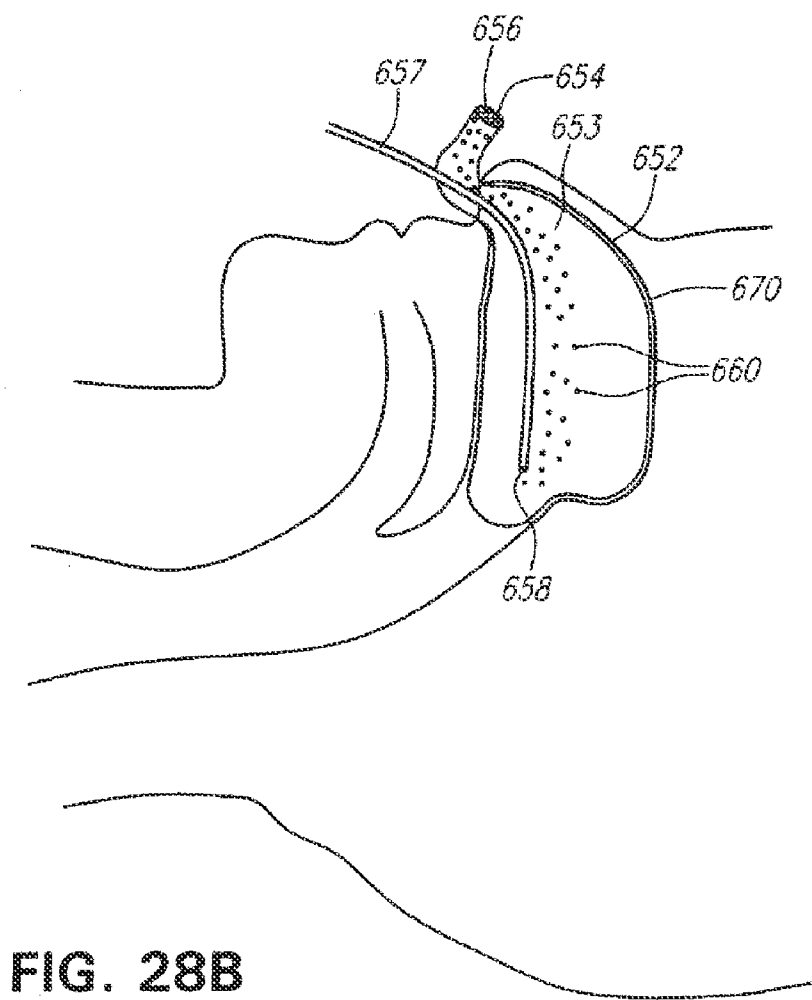
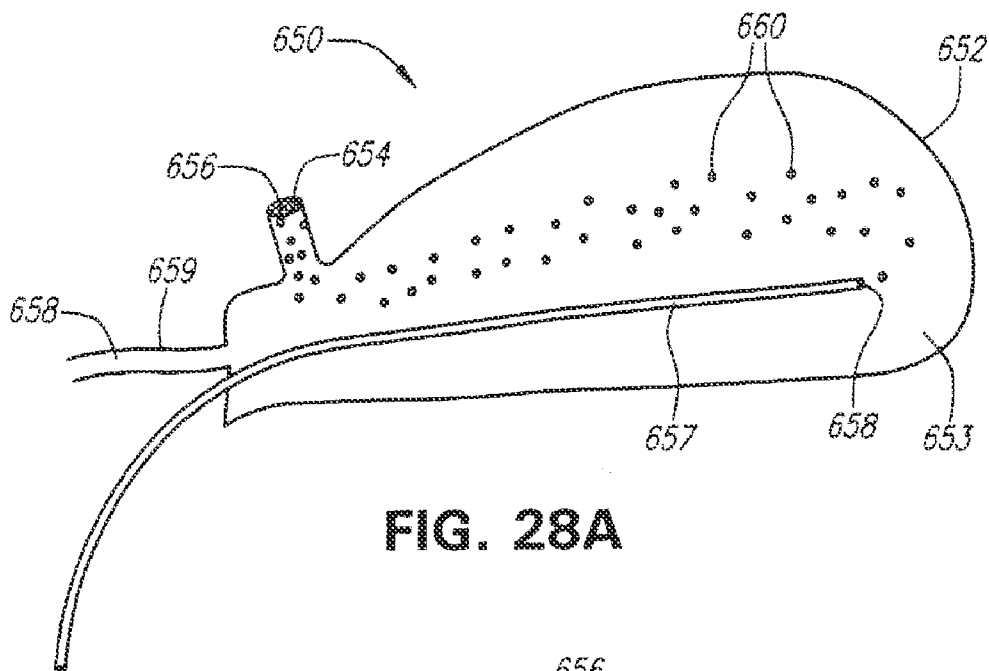

FIG. 27



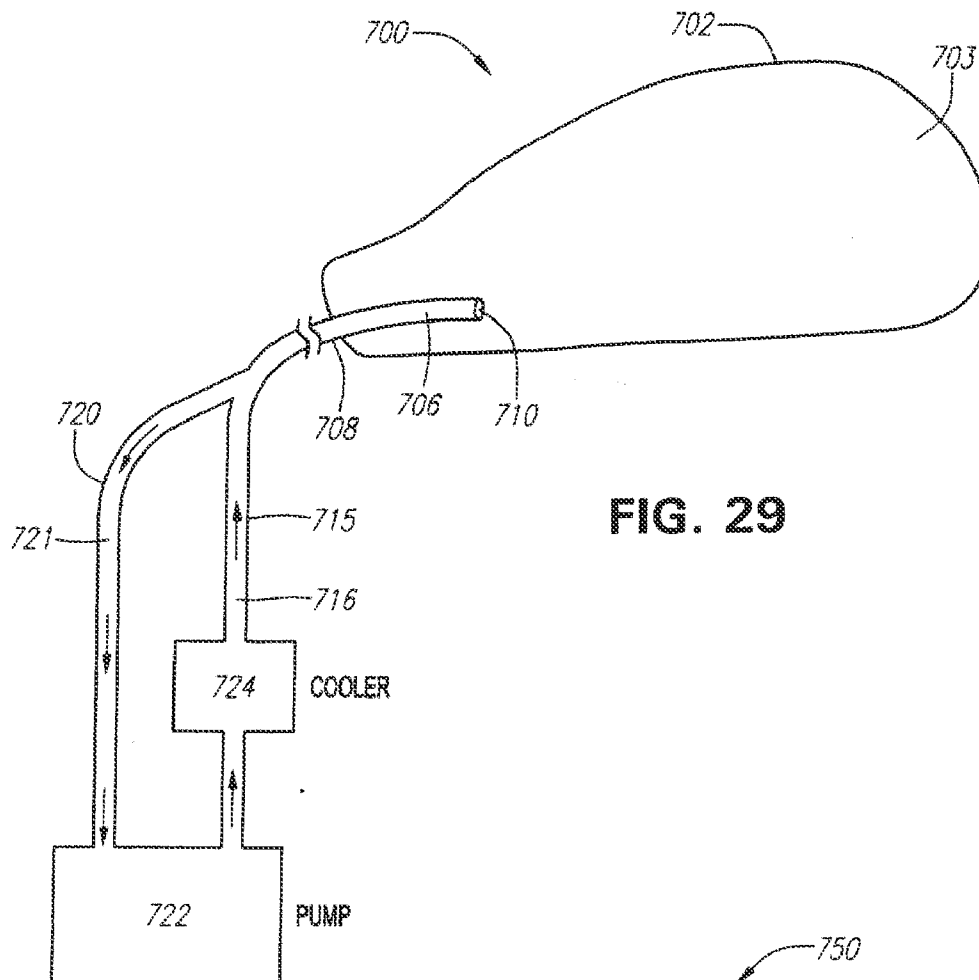

FIG. 29

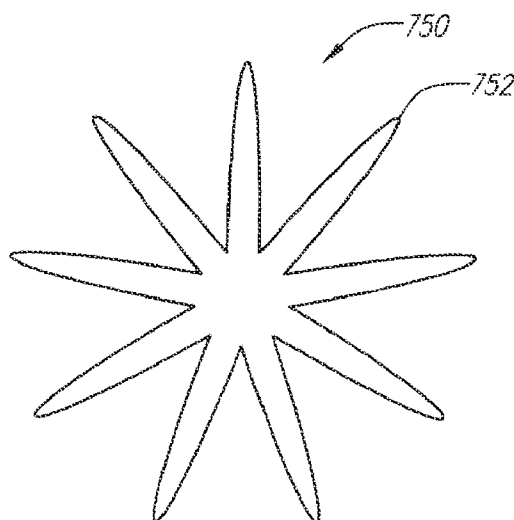

FIG. 30

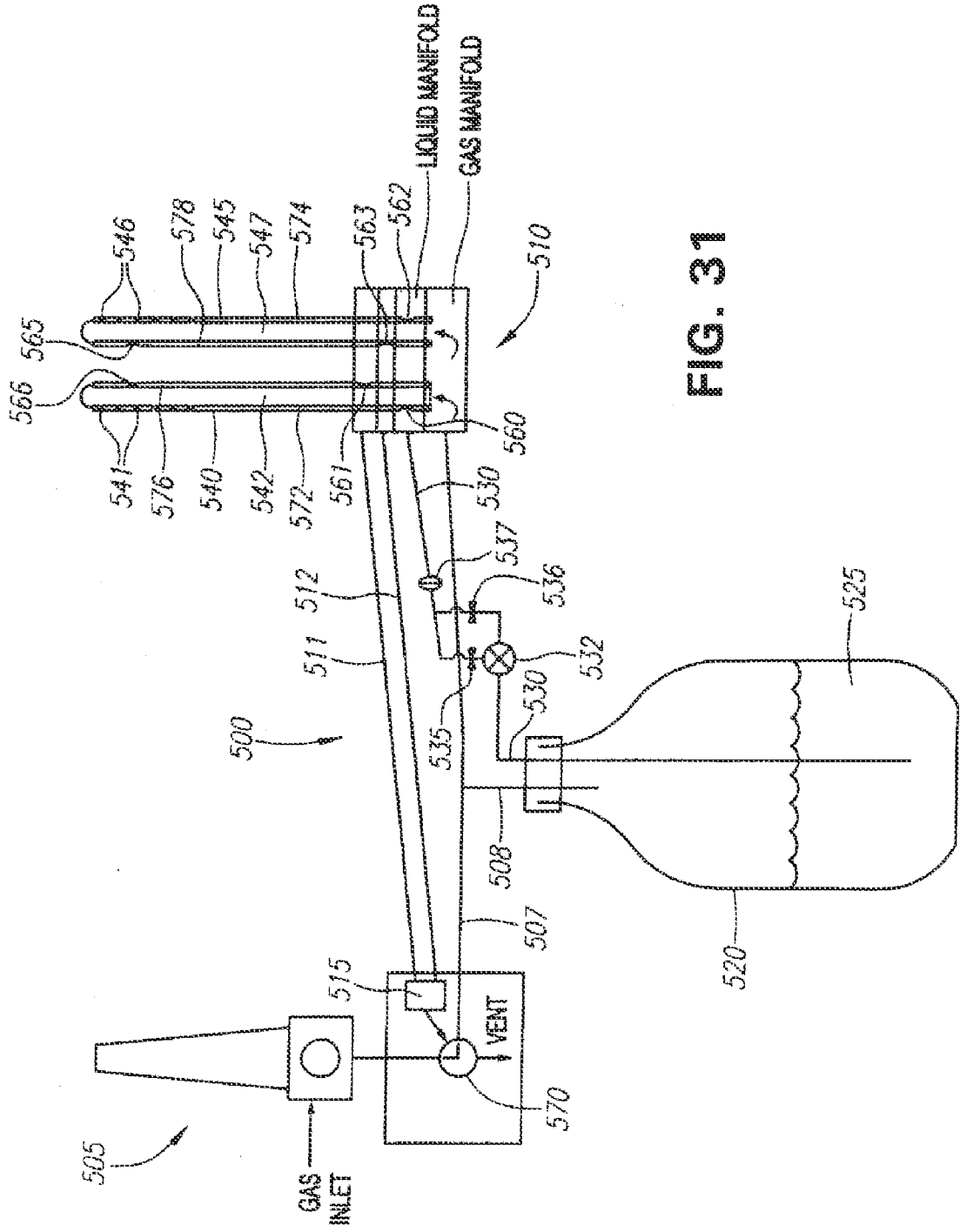

FIG. 31

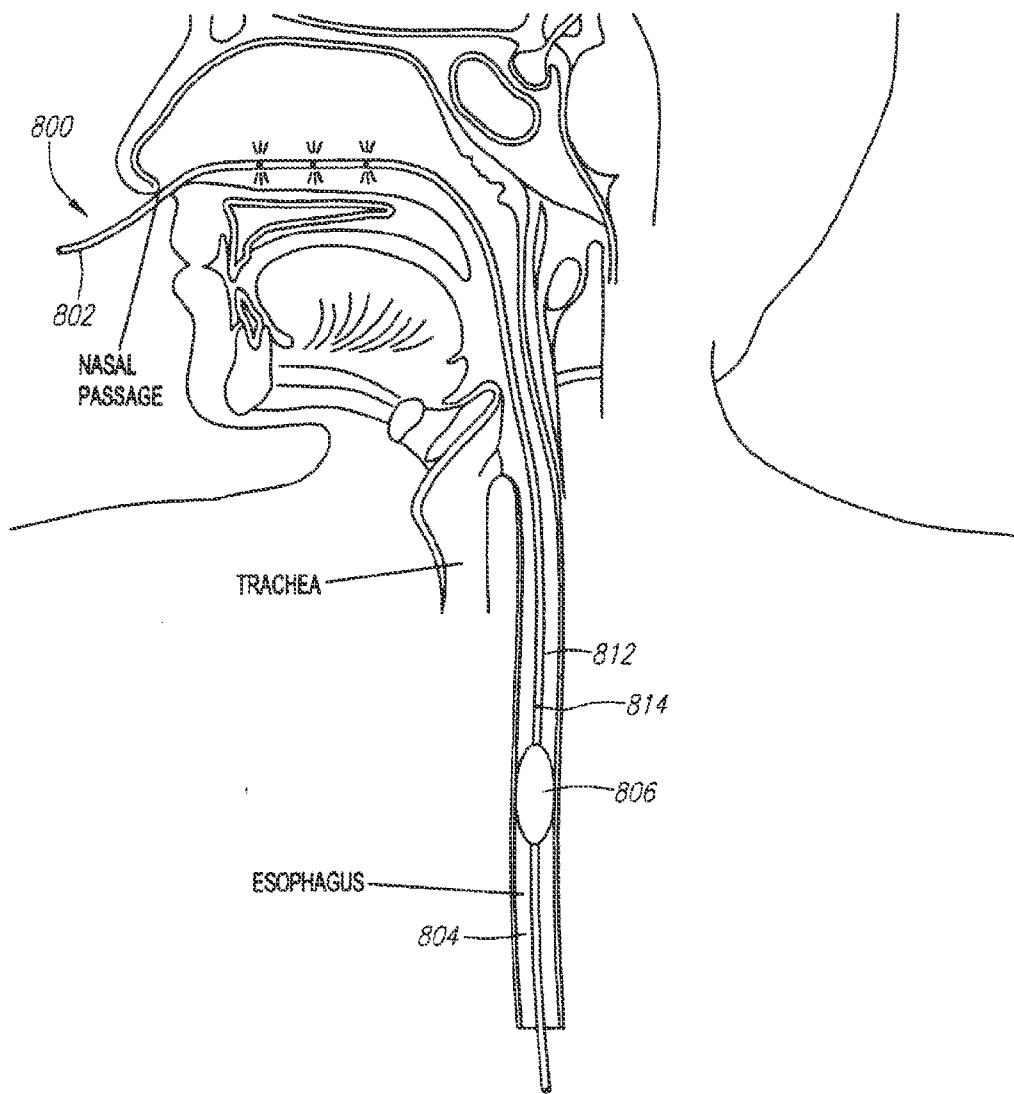

FIG. 32A

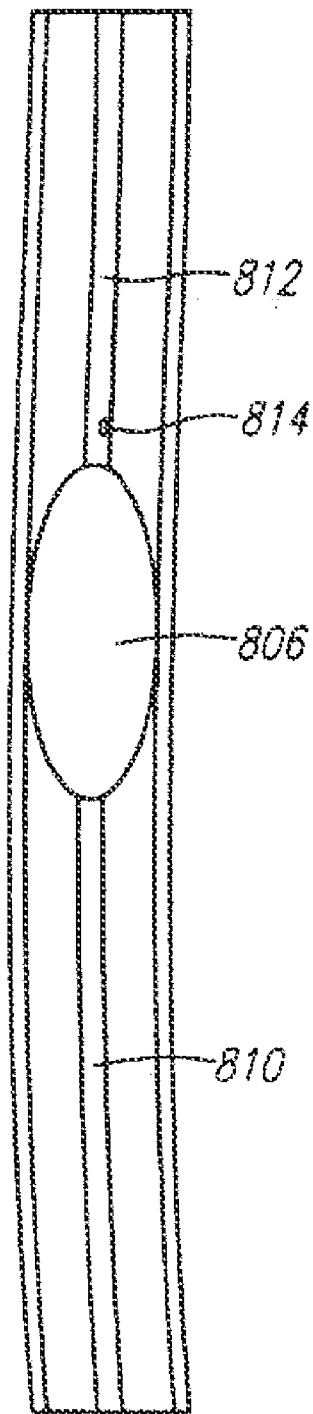

FIG. 32B

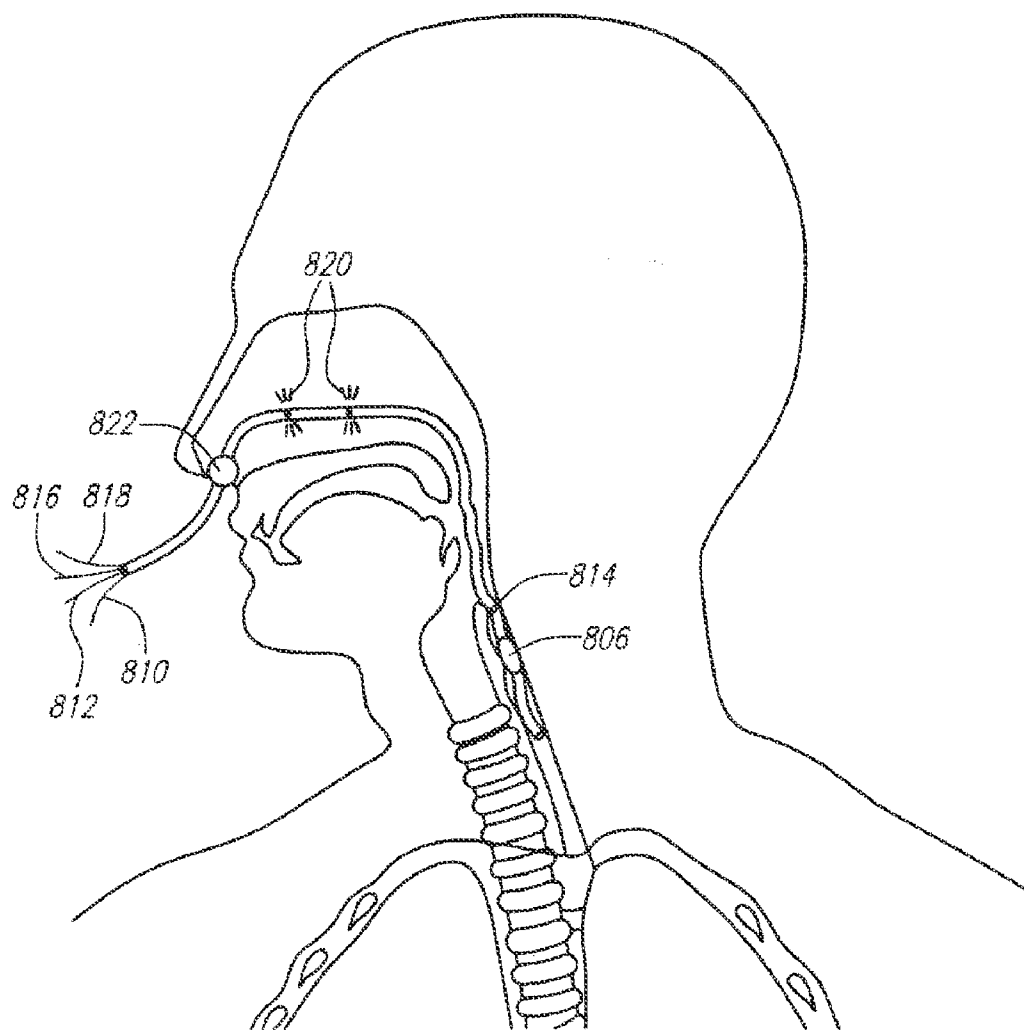

FIG. 33

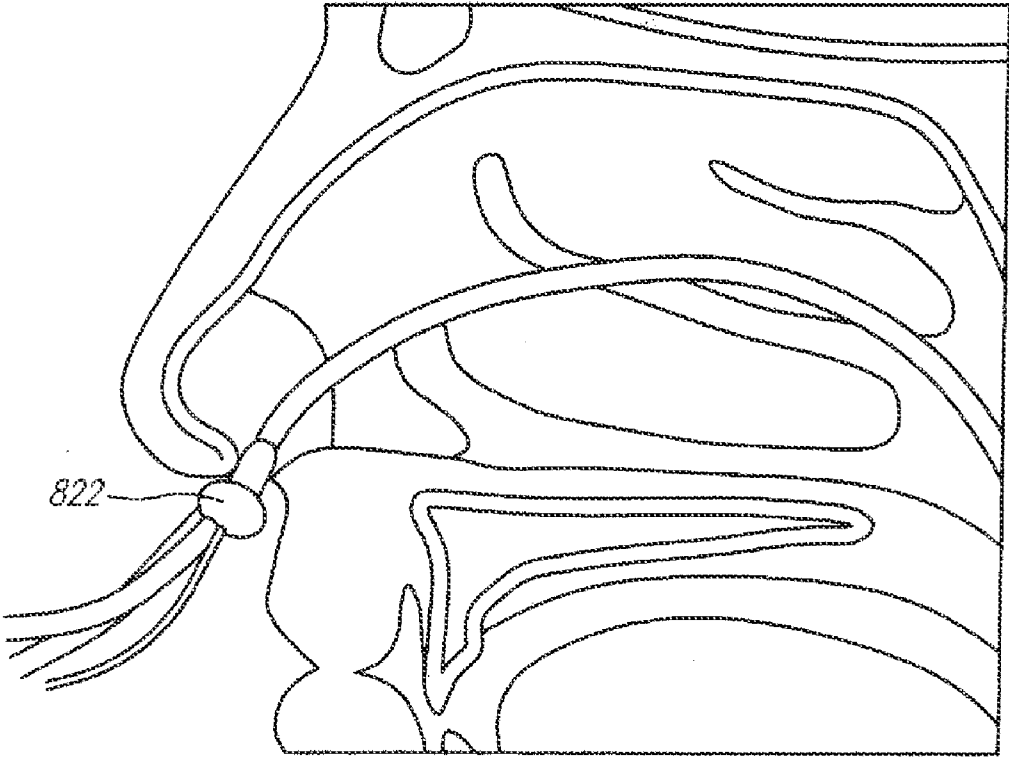

FIG. 34

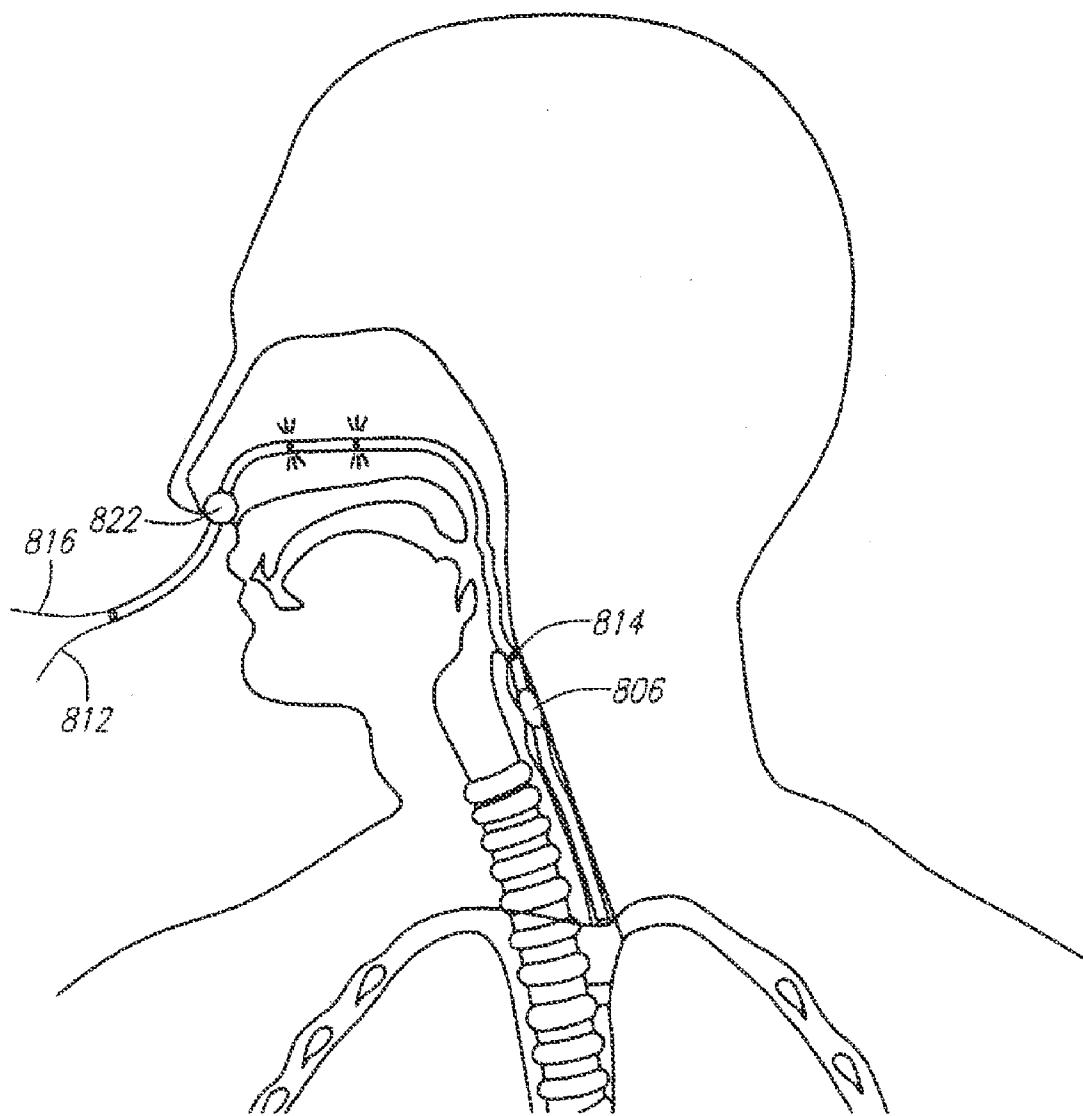

FIG. 35

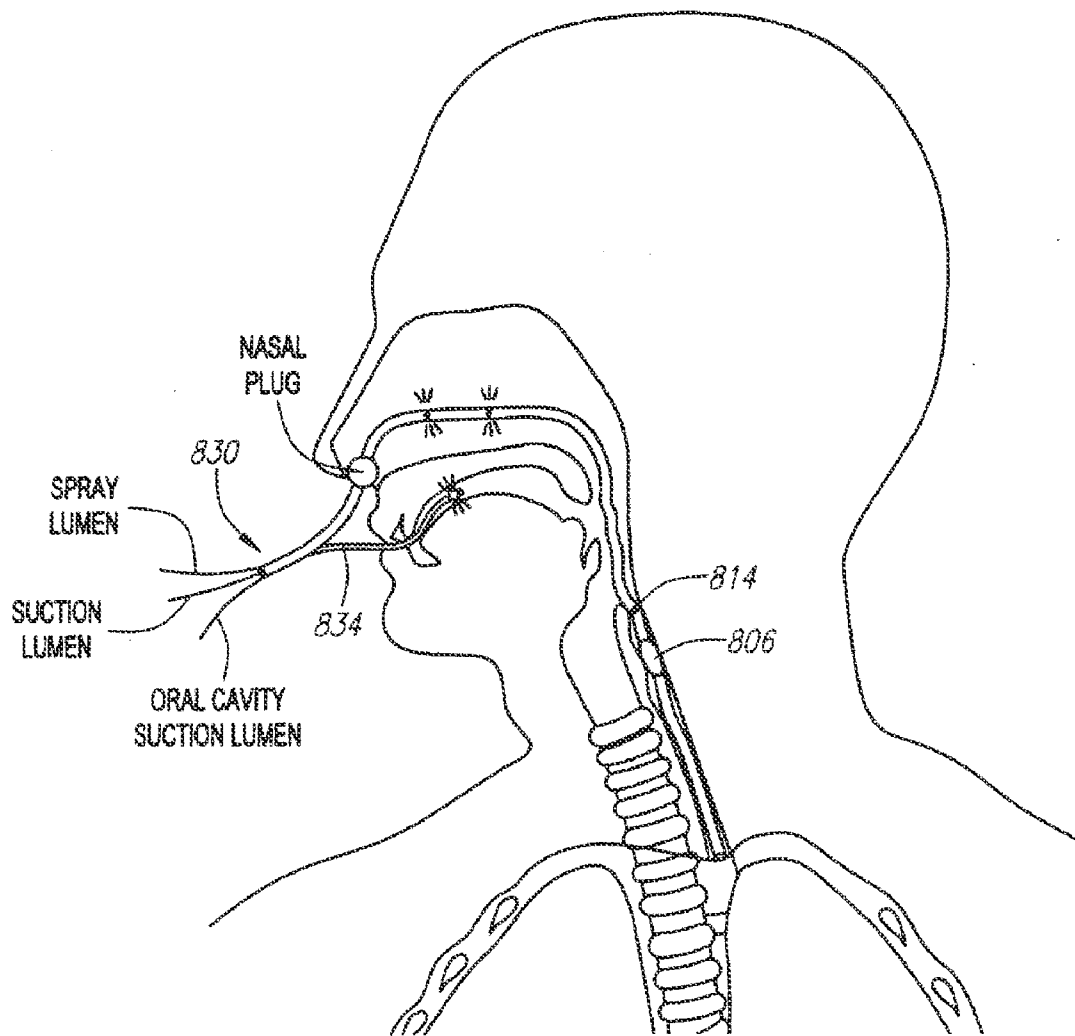

FIG. 36

Nasal PFC Spray Cooling Summary

Run #	PFC	PFC Flow (mL/min)	O2 Flow (L/min)	Bias Flow (L/min)	Cooling Rate (°C/hr)				Notes	V/Q
					Head--F	Head--V	Head--S	Vasc		
11a	PP1	40	16	8	30	31	—	10.6	2.7	400
11b	PP1	25	18	8	26	26	—	5	2.1	720
12a	PP2	35	18	8	30	20	12.6	3	2.8	514
12b	PP2	32	18	8	8.6	10	8.2	7.3	4.4	563
13a	PP2	35	20	0	15.2	12.4	7.4	2.6	1.4	571
13b	PP2	26	18	8	20	15	8	2.4	2.5	692
14a	PP1	19	10	20	17	1.3	1.4	0.6	1.3	526
14b	PP1	47	10	20	3.9	3.3	3.3	1.3	1.2	213
14c	PP1	39	20	8	5.9	6.2	6.2	1.7	1.8	513
15	PP1	26	25	20						962
16	PP1	32.8	20	10					TGI flow decreased after gas on, Q changed when PFC added	610

FIG. 37

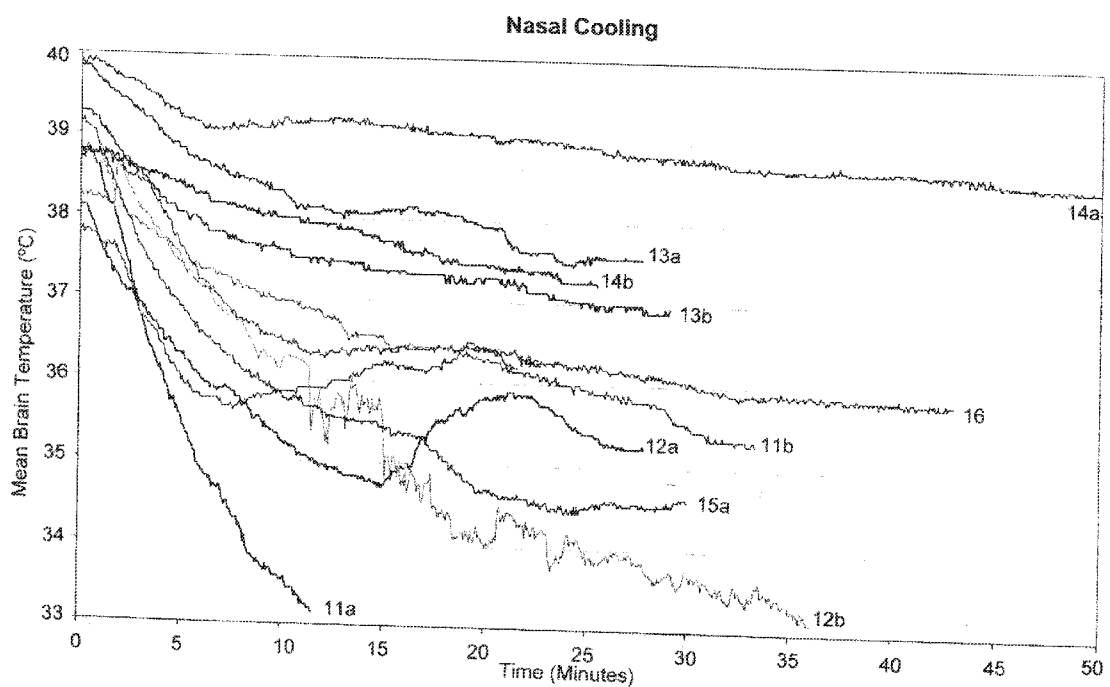

FIG. 38

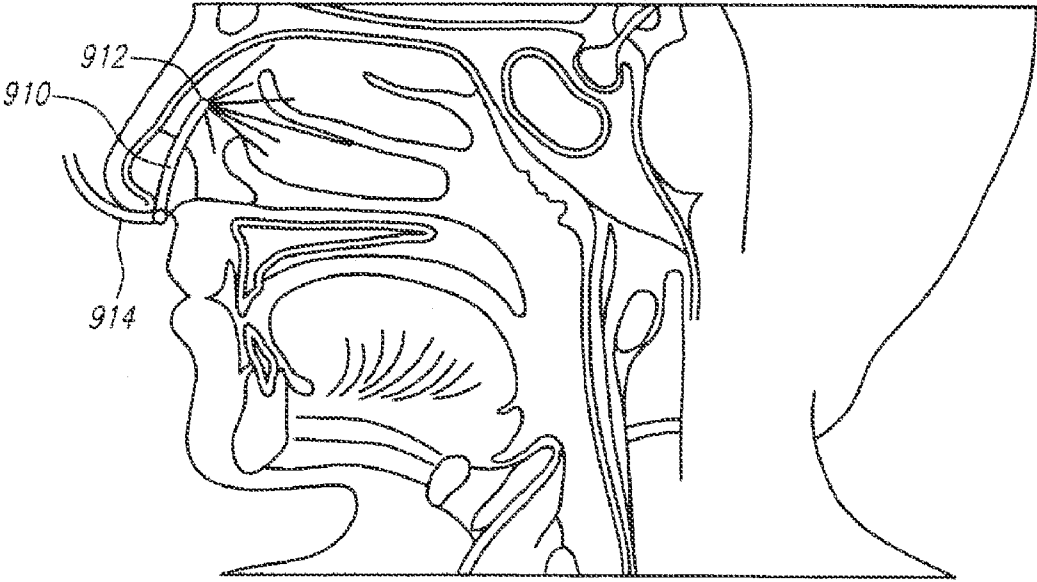

FIG. 39

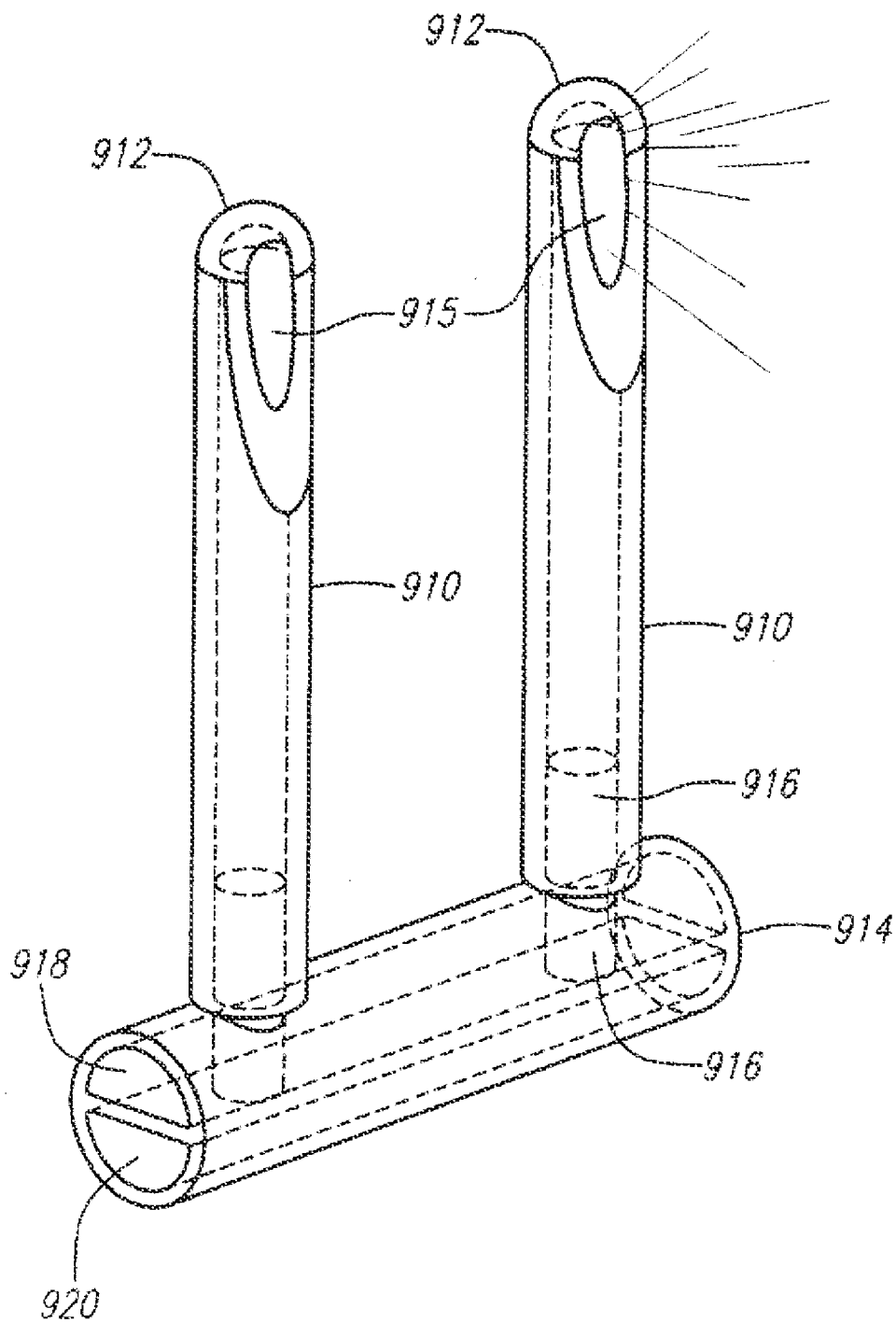

FIG. 40

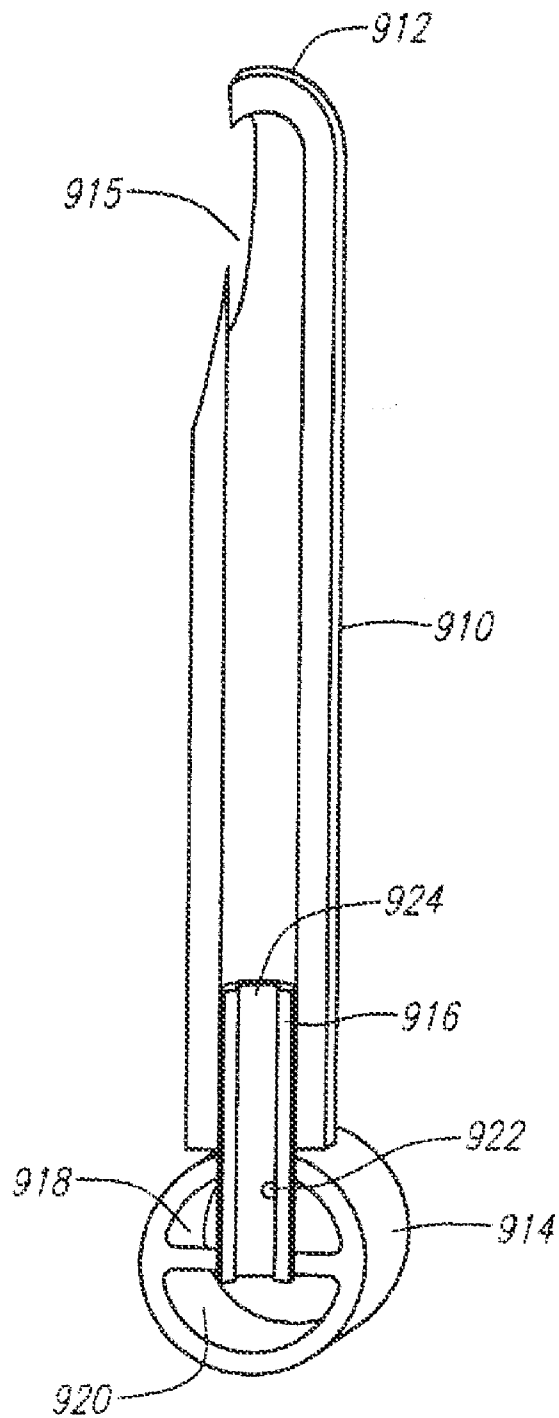

FIG. 41

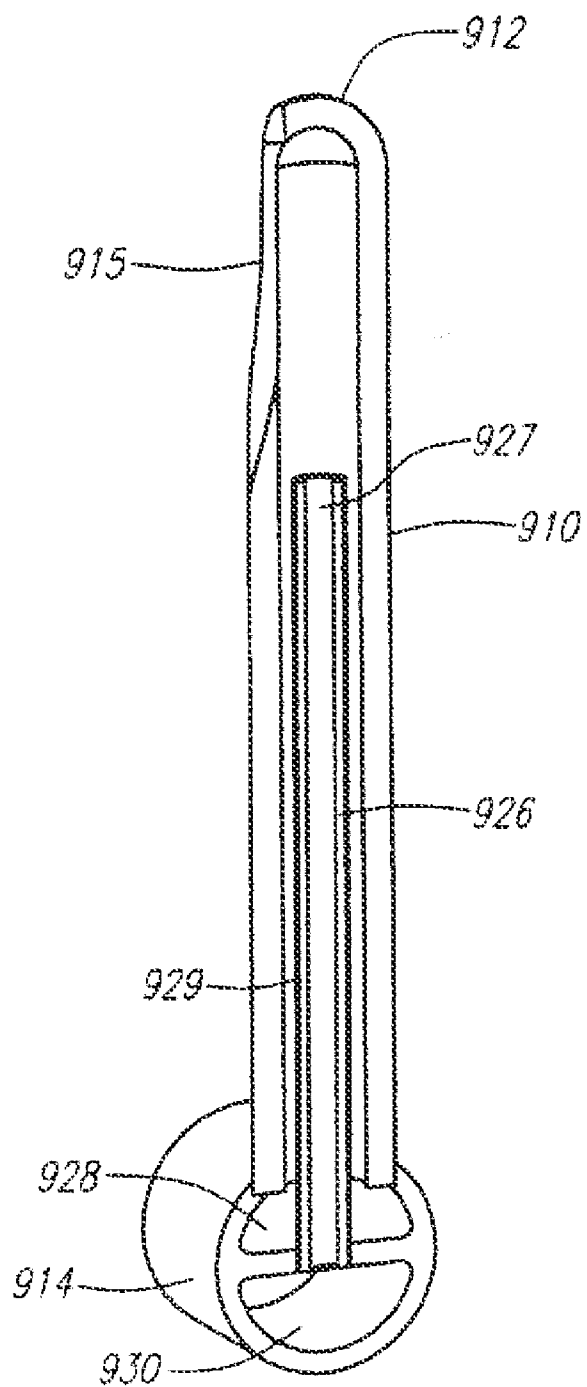

FIG. 42

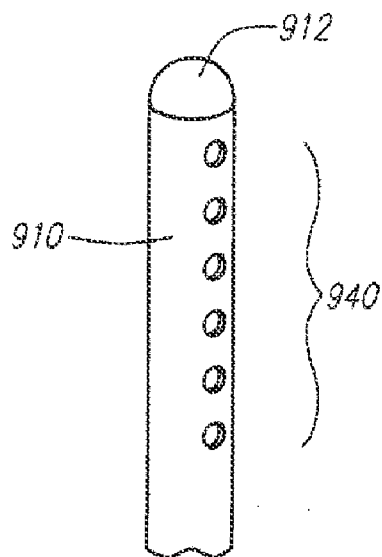

FIG. 43A

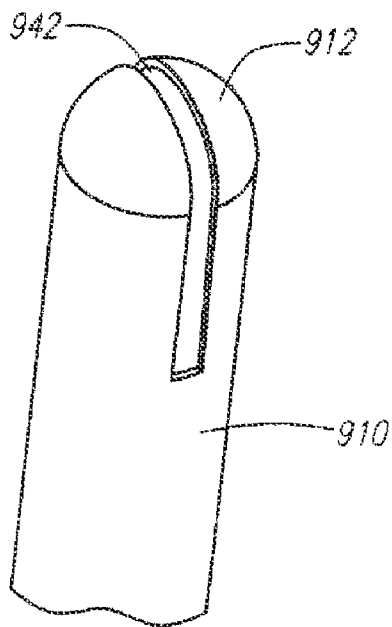

FIG. 43B

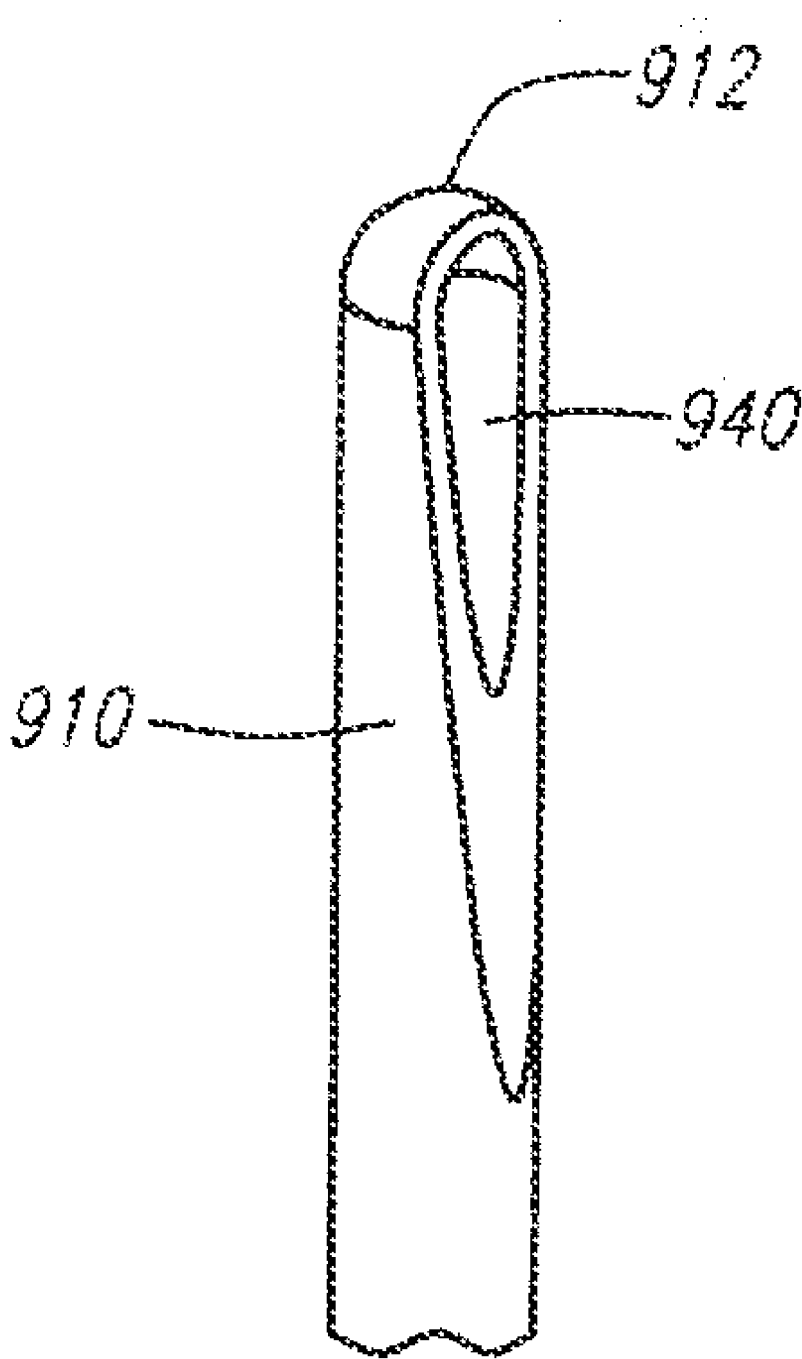

FIG. 43C

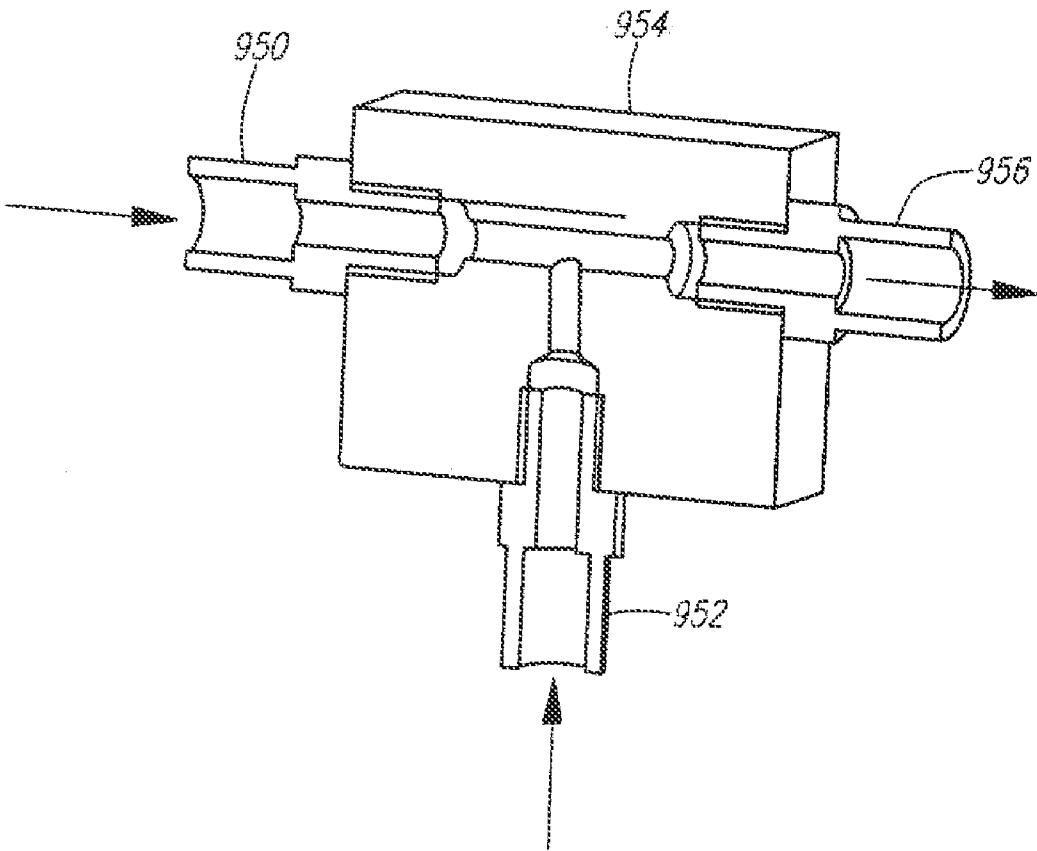

FIG. 44

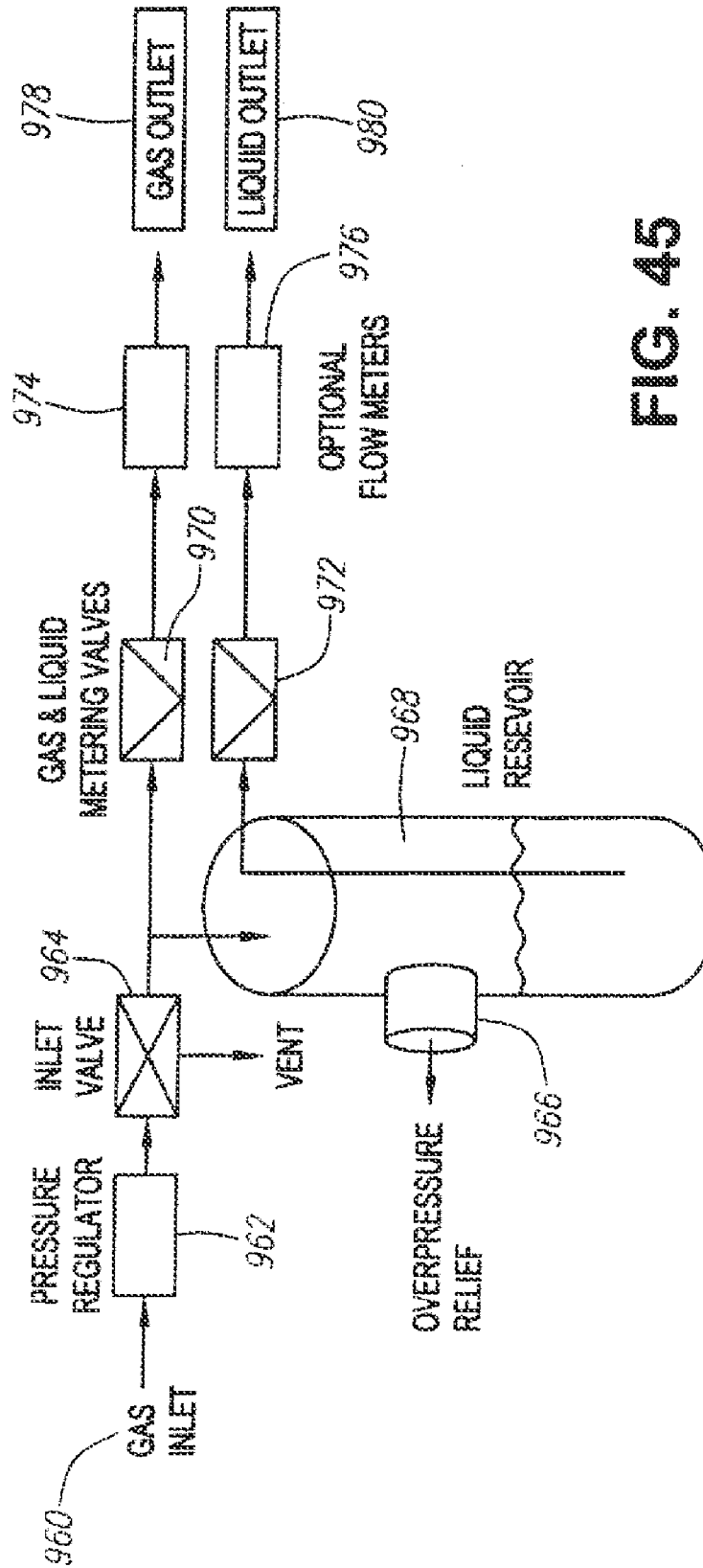

FIG. 45

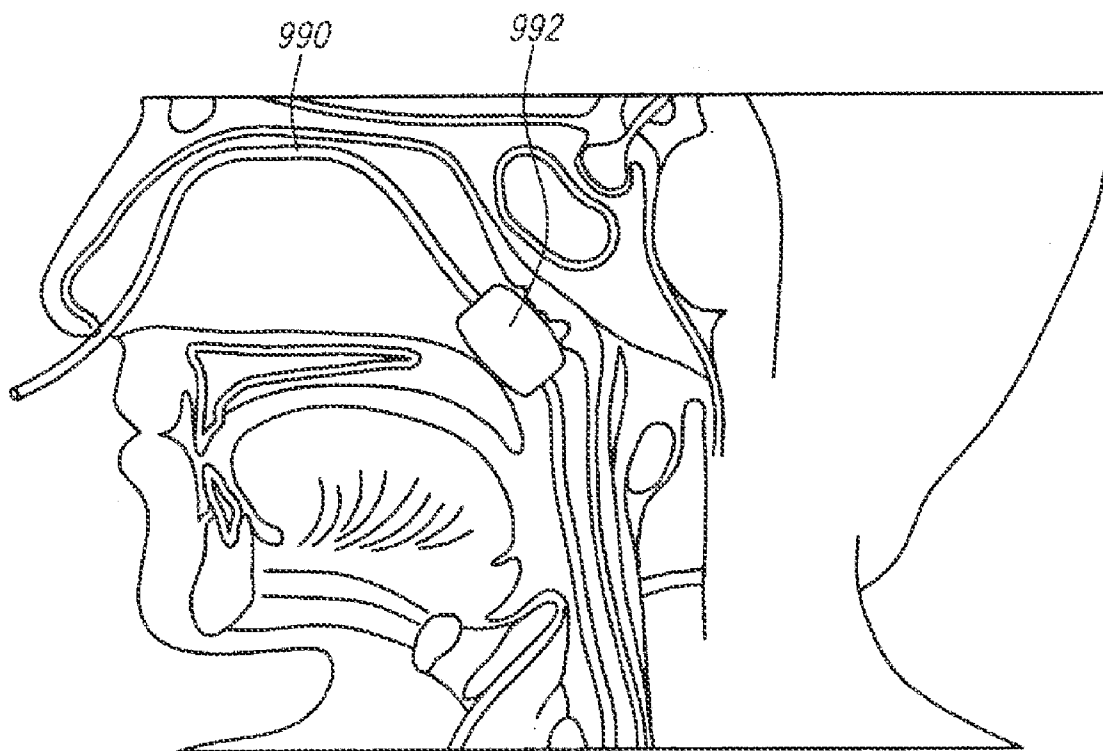

FIG. 46

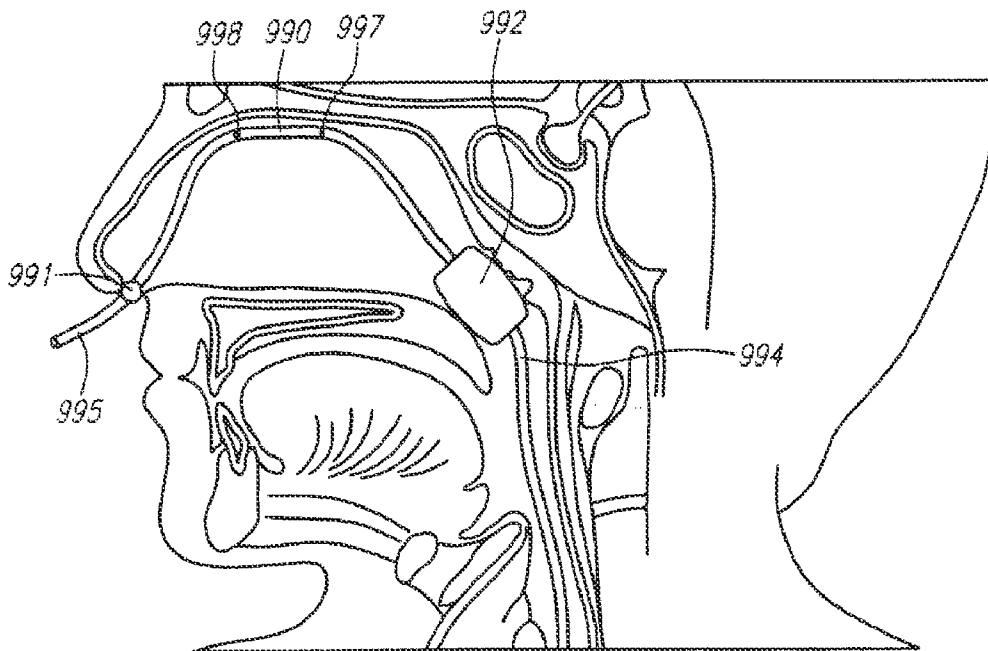

FIG. 47

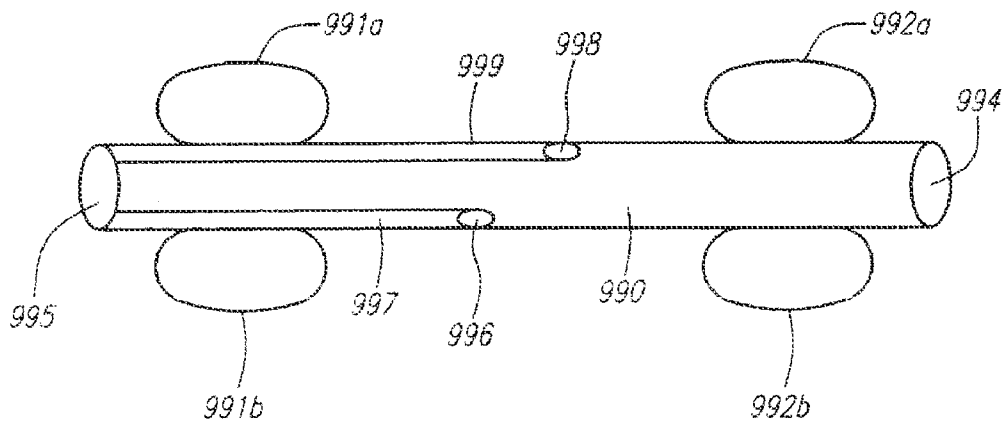

FIG. 48

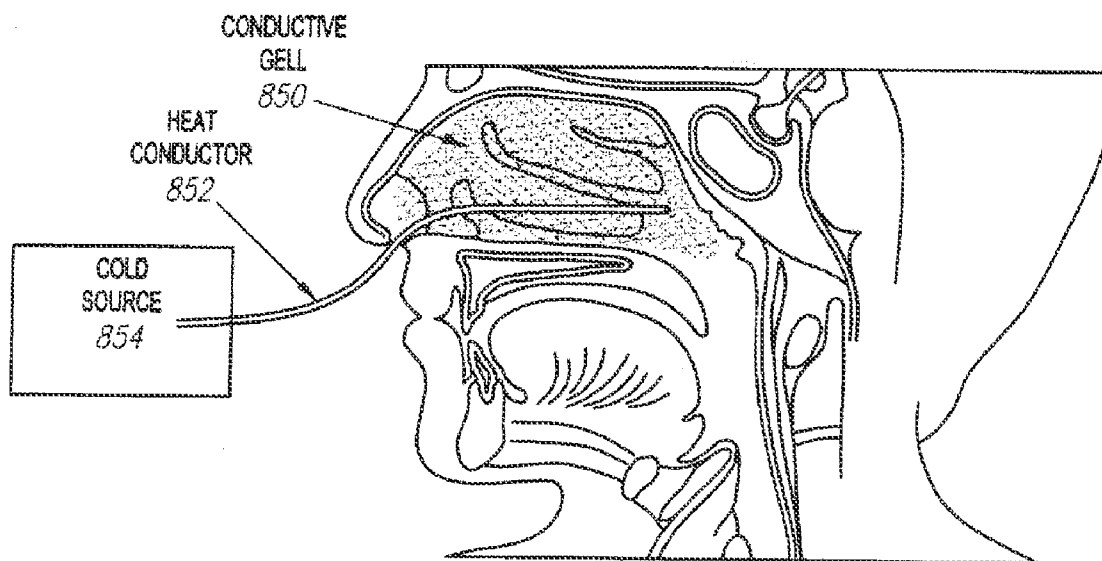

FIG. 49

**METHODS AND DEVICES FOR
NON-INVASIVE CEREBRAL AND SYSTEMIC
COOLING**

[0001] This application is a continuation in part of U.S. application Ser. No. 11/432,285, entitled “Methods and Devices for Non-Invasive Cerebral and Systemic Cooling,” filed Dec. May 10, 2006, which claims the benefit of the following provisional applications: U.S. provisional patent application Ser. No. 60/681,068, entitled “Methods and Devices for Non-Invasive Cerebral and Systemic Cooling,” filed May 13, 2005; U.S. provisional patent application Ser. No. 60/717,590, entitled “Methods and Devices for Non-Invasive Cerebral and Systemic Cooling,” filed Sep. 16, 2005; and U.S. provisional patent application Ser. No. 60/737,025, entitled “Methods and Devices for Non-Invasive Cerebral and Systemic Cooling,” filed Nov. 15, 2005, all of which are expressly incorporated herein by reference in their entirety for all purposes.

FIELD OF THE INVENTION

[0002] The invention relates to cerebral and systemic cooling via the nasal cavity, oral cavity, and other parts of the body, and more particularly to methods and devices for cerebral and systemic cooling using liquids or liquid mists with boiling points above body temperature and for delivering liquid mists to the nasopharyngeal cavity.

BACKGROUND OF THE INVENTION

[0003] Patients experiencing cerebral ischemia often suffer from disabilities ranging from transient neurological deficit to irreversible damage (stroke) or death. Cerebral ischemia, i.e., reduction or cessation of blood flow to the central nervous system, can be characterized as either global or focal. Global cerebral ischemia refers to reduction of blood flow within the cerebral vasculature resulting from systemic circulatory failure caused by, e.g., shock, cardiac failure, or cardiac arrest. Within minutes of circulatory failure, tissues become ischemic, particularly in the heart and brain.

[0004] The most common form of shock is cardiogenic shock, which results from severe depression of cardiac performance. The most frequent cause of cardiogenic shock is myocardial infarction with loss of substantial muscle mass. Pump failure can also result from acute myocarditis or from depression of myocardial contractility following cardiac arrest or prolonged cardiopulmonary bypass. Mechanical abnormalities, such as severe valvular stenosis, massive aortic or mitral regurgitation, acutely acquired ventricular septal defects, can also cause cardiogenic shock by reducing cardiac output. Additional causes of cardiogenic shock include cardiac arrhythmia, such as ventricular fibrillation. With sudden cessation of blood flow to the brain, complete loss of consciousness is a sine qua non in cardiac arrest. Cardiac arrest often progresses to death within minutes if active interventions, e.g., cardiopulmonary resuscitation (CPR), defibrillation, use of inotropic agents and vasoconstrictors such as dopamine, dobutamine, or epinephrine, are not undertaken promptly. The most common cause of death during hospitalization after resuscitated cardiac arrests is related to the severity of ischemic injury to the central nervous system, e.g., anoxic encephalopathy. The ability to resuscitate patients of

cardiac arrest is related to the time from onset to institution of resuscitative efforts, the mechanism, and the clinical status of the patient prior to the arrest.

[0005] Focal cerebral ischemia refers to cessation or reduction of blood flow within the cerebral vasculature resulting in stroke, a syndrome characterized by the acute onset of a neurological deficit that persists for at least 24 hours, reflecting focal involvement of the central nervous system. Approximately 80% of the stroke population is hemispheric ischemic strokes, caused by occluded vessels that deprive the brain of oxygen-carrying blood. Ischemic strokes are often caused by emboli or pieces of thrombotic tissue that have dislodged from other body sites or from the cerebral vessels themselves to occlude in the narrow cerebral arteries more distally. Hemorrhagic stroke accounts for the remaining 20% of the annual stroke population. Hemorrhagic stroke often occurs due to rupture of an aneurysm or arteriovenous malformation bleeding into the brain tissue, resulting in cerebral infarction. Other causes of focal cerebral ischemia include vasospasm due to subarachnoid hemorrhage from head trauma or iatrogenic intervention.

[0006] Current treatment for acute stroke and head injury is mainly supportive. A thrombolytic agent, e.g., tissue plasminogen activator (t-PA), can be administered to non-hemorrhagic stroke patients. Treatment with systemic t-PA is associated with increased risk of intracerebral hemorrhage and other hemorrhagic complications. Aside from the administration of thrombolytic agents and heparin, there are no therapeutic options currently on the market for patients suffering from occlusion focal cerebral ischemia. Vasospasm may be partially responsive to vasodilating agents. The newly developing field of neurovascular surgery, which involves placing minimally invasive devices within the carotid arteries to physically remove the offending lesion, may provide a therapeutic option for these patients in the future, although this kind of manipulation may lead to vasospasm itself.

[0007] In both stroke and cardiogenic shock, patients develop neurological deficits due to reduction in cerebral blood flow. Thus treatments should include measures to maintain viability of neural tissue, thereby increasing the length of time available for interventional treatment and minimizing brain damage while waiting for resolution of the ischemia. New devices and methods are thus needed to minimize neurologic deficits in treating patients with either stroke or cardiogenic shock caused by reduced cerebral perfusion.

[0008] Research has shown that cooling the brain may prevent the damage caused by reduced cerebral perfusion. Initially research focused on selective cerebral cooling via external cooling methods. Studies have also been performed that suggest that the cooling of the upper airway can directly influence human brain temperature, see for example *Direct cooling of the human brain by heat loss from the upper respiratory tract*, Zenon Mariak, et al. 8750-7587 *The American Physiological Society* 1999, incorporated by reference herein in its entirety. Furthermore, because the distance between the roof of the nose and the floor of the anterior cranial fossa is usually only a fraction of a millimeter, the nasal cavity might be a site where respiratory evaporative heat loss or convection can significantly affect adjacent brain temperatures, especially because most of the warming of inhaled air occurs in the uppermost segment of the airways. Thus, it would be

advantageous to develop a device and method for achieving cerebral cooling via the nasal and/or oral cavities of a patient.

SUMMARY OF THE INVENTION

[0009] The invention relates to methods, devices, and compositions for cerebral cooling, preferably via the nasal and/or oral cavities. The cooling occurs by direct heat transfer through the nasopharynx as well as by hematogenous cooling through the carotids as they pass by the oropharynx and through the Circle of Willis, which lies millimeters away from the pharynx. The direct cooling will be obtained through evaporative heat loss of a nebulized liquid in the nasal cavity, oral cavity, and/or throat. Additionally, cooling may occur through convection in the nasal cavity. Such cerebral cooling may help to minimize neurologic deficits in treating patients with either stroke or cardiogenic shock caused by reduced cerebral perfusion or in the treatment of migraines. In the following description, where a cooling assembly, device, or method is described for insertion into a nostril of a patient, a second cooling assembly or device can optionally also be inserted into the other nostril to maximize cooling.

[0010] In one embodiment, the invention provides a method for cerebral cooling. An elongate member can be inserted into a nasal cavity of a patient through the patient's nostril. The elongate member may have a proximal end, a distal end, a first lumen extending therebetween, and a plurality of ports in fluid communication with the first lumen. A perfluorocarbon spray and a gas is then delivered onto a surface of the patient's nasal cavity through the plurality of ports in the elongate member. The evaporation of the perfluorocarbon from the nasal cavity, which is enhanced by the gas, results in reduction of the cerebral temperature of the patient by at least 1° C. in one hour. Alternatively, the cerebral temperature may be reduced by at least 2° C., alternatively at least 3° C., alternatively at least 4° C., alternatively at least 5° C., alternatively at least 6° C., alternatively at least 7° C., alternatively at least 8° C., alternatively at least 9° C., alternatively at least 10° C. The elongate member may further comprise a second lumen extending between the proximal and distal ends. The method may further include the steps of infusing the perfluorocarbon into the first lumen, infusing the gas into the second lumen, and combining the perfluorocarbon and gas at the plurality of ports to form a perfluorocarbon spray. The gas may be oxygen. Additionally, the perfluorocarbon may have a boiling point above 37° C., alternatively between about 0° C. and about 160° C., alternatively between about 25° C. and about 140° C. The spray may be directed towards the roof of the nasal cavity and onto the turbinates. Additionally, water or one or more drugs may also be delivered with the perfluorocarbon spray. The delivery of water may reduce the drying of the nasal tissues.

[0011] In another embodiment, the invention provides an elongate member capable of delivering a nebulized liquid spray to a patient's nasal cavity. The elongate member has a proximal end, a distal end, and a lumen extending therebetween. An outer wall of the elongate member has a plurality of ports that are in fluid communication with the lumen. The plurality of ports may be spaced apart axially and longitudinally along the length of the elongate tubular member such that nebulized spray from the ports will substantially cover the whole nasal cavity. The elongate tubular member may comprise a first lumen extending between the proximal and distal ends for transporting the liquid. The elongate tubular

member may also comprise a second lumen extending between the proximal and distal ends for transporting a compressed gas.

[0012] In use, the elongate member is inserted into a nasal cavity of a patient through one of the patient's nostrils and positioned in the nasal cavity. The elongate member may be positioned in the upper nasopharynx such that the nebulized spray will be delivered over the nasal plexus and the carotids. The proximal end of the elongate member is placed in fluid communication with a liquid source. The liquid is nebulized and a nebulized liquid spray is delivered into the patient's nasal cavity through the plurality of ports. In one embodiment, the liquid is nebulized at each of the plurality of ports on the elongate tubular member. The liquid and compressed gas may be separately transported to the ports via the first and second lumens of the elongate tubular member and only combined at the ports. The volume of liquid delivered may range from about 0.1 to about 20 liters, alternatively about 1 to about 20 liters, alternatively about 1 to about 15 liters, alternatively about 1 to about 10 liters, alternatively about 1 to about 8 liters, alternatively about 2 to about 6 liters. Unevaporated liquid may also be suctioned or otherwise removed from the patient's nasal pharynx. A cooling helmet may also be used to help lower the cerebral temperature of the patient. Furthermore, a warming blanket may be used to maintain the systemic temperature of the patient, or prevent the systemic temperature from decreasing as much as the cerebral temperature. A vasodilator may also be delivered to the patient's nasal cavity to enhance vascular cooling capacity. Additionally or alternatively, a humidifier, such as isotonic saline or water, may also be delivered into the patient's nasal cavity. Additional air or oxygen may be delivered to the patient to enhance the evaporative process through a mask placed over the nose of the patient, such as a CPAP nasal mask.

[0013] The patient's cerebral, systemic, and nasal temperatures may also be monitored during this method. The nebulized spray may be delivered at a flow rate sufficient to achieve a gradient of not greater than about 0.5° C. between the outer surface of the brain and the inner core of the brain. The nebulized spray may also be delivered at a flow rate sufficient to achieve a gradient of at least about 1.0° C. between the cerebral temperature and the systemic temperature. The nebulized spray may also be delivered at a flow rate sufficient to achieve cerebral cooling at a rate greater than about 1.0° C. in hour. The nebulized spray may also be delivered at a flow rate sufficient to achieve a temperature in the nasal cavity of about 4.0° C. or less.

[0014] In an alternative embodiment according to this invention, a nasal catheter may be used to deliver a spray of liquid to the nasal cavity of a patient. The nasal catheter may be placed in the nares of the patient's nose and may be angled to direct the spray outlet at the desired structures of the nose, for example, the nasal conchae. In addition, the distal end of the nasal catheter and may be designed to cause the spray to spread in a pattern which will allow the gas and liquid mixture to contact as much of the desired tissue as possible. Spreading the spray will also minimize the potential of medical trauma that could result from a high velocity stream of liquid directed at the tissue of the nasal cavity. In addition, the distal end of the catheter may be 'tipped', i.e., sealed off in a rounded fashion to provide a smooth surface to avoid damaging the sensitive nasal tissues.

[0015] A number of methods for spreading the spray pattern are contemplated. For example, the spray pattern may be

formed by creating one or more holes along opposite sides of the catheter tip, which would create a broad, flat spray perpendicular to the axis of the catheter. This pattern may be further altered by changing the size, location and number of holes in the catheter. In addition, this pattern may further include a hole in the tip of the catheter to produce some additional flow in the axial direction. An alternative spray pattern may be formed by making a slit in the tip of the catheter to produce a fan shaped spray centered on the axial direction of the catheter. This pattern may be further altered by varying the width of the slit and the length the slit extends down the sides of the catheter. In addition, multiple, intersecting slits may be made in the catheter tip. Another alternative spray pattern may be formed by making a straight or curved cut along opposite sides of the catheter wall. The skived cut may extend from and include a portion of the tip. This configuration will produce a wide 'fan' shaped spray covering a broad angle from the perpendicular to the axial direction of the catheter. In addition, any of the above described patterns could be combined to create additional spray patterns for the nasal catheter.

[0016] In an alternative embodiment, the invention provides a cooling assembly for insertion into a nasal cavity of a patient through a patient's nostril. The cooling assembly includes a flexible balloon defining a chamber, a first elongate tubular member having a lumen in fluid communication with the chamber, and a second elongate tubular member having a lumen in fluid communication with the chamber. The cooling assembly may further comprise a third elongate tubular member having a lumen extending from a proximal end to a distal end, wherein the flexible balloon is mounted circumferentially about the third elongate tubular member.

[0017] In use, the cooling assembly is inserted into a nasal cavity of a patient through the patient's nostril. A liquid having a temperature between about -20°C . and about 37°C . is infused through the lumen of the first elongate tubular member into the chamber of the flexible balloon. The liquid is then withdrawn, suctioned, or drained from the chamber through the lumen of the second tubular member. During this process, the chamber of the flexible balloon expands to place the flexible balloon in contact with the nasal cavity. The method may further include the step of recirculating the liquid by infusing the liquid through the lumen of the first elongate tubular member and withdrawing the liquid through the lumen of the second elongate tubular member. The liquid may be infused using a pump at a flow rate of between about 5 ml/min and about 5 L/min, alternatively between about 100 ml/min and about 1 L/min, alternatively between about 200 ml/min and about 800 ml/min, alternatively between about 300 ml/min and about 700 ml/min, alternatively between about 400 ml/min and about 600 ml/min, alternatively between about 450 ml/min and about 550 ml/min, alternatively about 500 ml/min. Where the cooling assembly comprises a flexible balloon mounted circumferentially about a third elongate tubular member having a lumen, the third elongate tubular member should be positioned such that the lumen is in fluid communication with the patient's nasopharynx, oropharynx, larynx, and/or esophagus, such that the patient can breathe through the lumen of the third elongate tubular member. Alternatively, a medical device could be passed through the lumen of the third elongate tubular member. A drug may also be eluted from a surface of the flexible balloon.

[0018] In an alternative embodiment, the invention provides a cooling assembly for insertion into a nasal cavity of a

patient through a patient's nostril. The cooling assembly includes a first balloon defining a chamber and having a port and a second balloon defining a chamber inside of the chamber of the first balloon. A first elongate tubular member has a lumen in fluid communication with the chamber of the second balloon and a second elongate tubular member also has a lumen in fluid communication with the chamber of the second balloon.

[0019] In use, the cooling assembly is inserted into a patient's nostril. The chamber of the first balloon is filled with a first liquid through the port to place the balloon in contact with the nasal cavity. A second liquid having a temperature between about -5°C . and about 5°C . is then infused through the lumen of the first elongate tubular member into the chamber of the second balloon. The second liquid exits the chamber of the second balloon through the lumen of the second elongate tubular member. The second liquid also reduces the temperature of the first liquid, such that a cerebral temperature of the patient is reduced by at least 1°C . in about one hour. A second cooling assembly could be inserted into the patient's other nostril to maximize cerebral cooling. The first liquid could be water or saline. The second liquid could be a PFC, anti-freeze solution, or a combination thereof.

[0020] In an alternative embodiment, the invention provides an alternative cooling assembly for insertion into a nasal cavity of a patient through a patient's nostril. The cooling assembly includes a balloon defining a chamber and having a first port with a gas-venting filter and a second port. A first elongate tubular member has a lumen in fluid communication with the chamber of the balloon.

[0021] In use, the cooling assembly is inserted into a patient's nostril. The chamber of the balloon is filled with a first liquid through the second port to place the balloon in contact with the nasal cavity. A second liquid having a temperature between about -5°C . and about 5°C . is then infused through the lumen of the first elongate tubular member into the first liquid in the chamber. After contact with the first liquid, the second liquid undergoes a phase transition to gas, and the gas is vented through the gas-venting filter. The second liquid also reduces the temperature of the first liquid, such that a cerebral temperature of the patient is reduced by at least 1°C . in about one hour. A second cooling assembly could be inserted into the patient's other nostril to maximize cerebral cooling. The first liquid could be water or saline. The second liquid could be a fluorocarbon having a boiling point below about 37°C ., such as Freon or other refrigerant.

[0022] In an alternative embodiment, the invention provides a cooling assembly for insertion into a nasal cavity of a patient through a patient's nostril. The cooling assembly includes a balloon defining a chamber. A branched tubular member comprises a first tubular member that branches into a second and a third tubular member, all of which have lumens. The lumen of the first tubular member is in fluid communication with the chamber and with the lumens of the second and third tubular members. A pump is connected to the second tubular member. A cooler is connected to the pump and to the third tubular member.

[0023] In use, the cooling assembly is inserted into a patient's nostril. The chamber of the balloon is infused with a liquid having a temperature between about -20°C . and about 37°C . through the lumens of the third and first tubular members. The liquid is then withdrawn from the chamber through the lumens of the first and second tubular members. The chamber of the balloon expands to place the surface of the

balloon in contact with the nasal cavity when the chamber is infused with liquid, such that a cerebral temperature of the patient is reduced by at least 1° C. in about one hour. A second cooling assembly could be inserted into the patient's other nostril to maximize cerebral cooling. The liquid can be continuously recirculated through the chamber of the balloon using a pump or other means. The liquid could be water, saline, PFC, anti-freeze solution, or a combination thereof.

[0024] In an alternative embodiment, the invention provides a cooling assembly for insertion into a nasal cavity of a patient through a patient's nostril. The cooling assembly includes a first elongate tubular member, a flexible balloon, and a second elongate tubular member. The first elongate tubular member, e.g., a nasogastric tube, has a proximal end, a distal end, a lumen therebetween, and a port at the distal end in fluid communication with the lumen. The flexible balloon is mounted circumferentially about the first elongate tubular member to the distal end, wherein the flexible balloon defines a chamber that is in fluid communication with the port and lumen of the first elongate tubular member. The second elongate tubular member has a proximal end, a distal end, and a lumen therebetween, wherein the lumen is in fluid communication with the chamber of the flexible balloon. The flexible balloon is sized such that, upon expansion, it will substantially fill the adjacent anatomy. For instance, the distal end of the flexible balloon is sized such that it can substantially fill the stomach upon expansion. Alternatively, a second flexible balloon having a chamber in fluid communication with the first flexible balloon and the port and lumen of the first elongate tubular member may be attached at the distal end of the flexible balloon. This second flexible balloon may be sized to substantially fill the patient's stomach upon expansion.

[0025] In use, the cooling assembly is inserted into a patient through a patient's nostril. The first elongate tubular member is advanced down the patient's throat, through the patient's esophagus, and into the patient's stomach. A liquid having a temperature between about -20° C. and about 37° C. is infused through the lumen of the first elongate tubular member into the chamber of the flexible balloon. The liquid is then withdrawn, drained, or suctioned from the chamber through the lumen of the second elongate tubular member. During this process, the chamber of the flexible balloon expands to place the flexible balloon in contact with the adjacent anatomy. The method may further include the step of recirculating the liquid by infusing the liquid through the lumen of the first elongate tubular member and withdrawing the liquid through the lumen of the second elongate tubular member. The liquid may be infused using a pump at a flow rate of between about 5 mL/min and about 5 L/min, alternatively between about 100 mL/min and about 1 L/min, alternatively between about 200 mL/min and about 800 mL/min, alternatively between about 300 mL/min and about 700 mL/min, alternatively between about 400 mL/min and about 600 mL/min, alternatively between about 450 mL/min and about 550 mL/min, alternatively about 500 mL/min. A drug may also be eluted from a surface of the flexible balloon.

[0026] In an alternative embodiment, the invention provides a modified laryngeal mask cooling assembly for insertion into a patient's throat. The cooling assembly includes a first elongate tubular member, a flexible toroidal balloon, and a second elongate tubular member. The first elongate tubular member has a proximal end, a distal end, a lumen therebetween, and a port at the distal end in fluid communication with the lumen. The flexible toroidal balloon defines a chamber

and is mounted at the distal end of the elongate tubular member. The second elongate tubular member has a proximal end, a distal end, and a lumen therebetween in fluid communication with the chamber of the flexible toroidal balloon. The third elongate tubular member has a proximal end, a distal end, and a lumen therebetween in fluid communication with the chamber of the flexible toroidal balloon. The assembly may also include a second flexible balloon located on the distal end of the first elongate tubular member, opposite of the flexible toroidal balloon.

[0027] In use, the cooling assembly is inserted into a patient's throat and positioned such that the flexible toroidal balloon is located over the larynx. A liquid having a temperature between about -20° C. and about 37° C. is infused through the lumen of the second elongate tubular member into the chamber of the flexible toroidal balloon. The liquid is then withdrawn, drained, or suctioned from the chamber through the lumen of the third elongate tubular member. During this process, the chamber of the flexible toroidal balloon expands to place the flexible balloon in contact with the adjacent anatomy, i.e., the epiglottis. The method may further include the step of recirculating the liquid by infusing the liquid through the lumen of the second elongate tubular member and withdrawing the liquid through the lumen of the third elongate tubular member. The liquid may be infused using a pump at a flow rate of between about 5 mL/min and about 5 L/min, alternatively between about 100 mL/min and about 400 mL/min, alternatively between about 150 mL/min and about 200 mL/min. A drug may also be eluted from a surface of the flexible toroidal balloon. Where the cooling system comprises a second flexible balloon, the second flexible balloon will also be infused with the liquid, either through the lumens of the second and third elongate members or through lumens of a fourth and a fifth elongate tubular member.

[0028] In an alternative embodiment, the invention provides a cooling assembly for insertion into a patient's oral cavity. The cooling assembly includes a flexible balloon or pad, a first tubular member, and a second tubular member. The flexible balloon or pad defines a chamber. The first tubular member has a proximal end, a distal end, a lumen therebetween, and a port in fluid communication with the lumen of the first tubular member and the chamber of the flexible balloon. The second tubular member has a proximal end, a distal end, a lumen therebetween, and a port in fluid communication with the lumen of the second tubular member and the chamber of the flexible balloon.

[0029] In use, the cooling assembly is inserted into a patient's mouth and positioned such that the flexible balloon or pad covers the retromandibular area or the peritonsillar region. A liquid having a temperature between about -20° C. and about 37° C. is infused through the lumen of the first tubular member into the chamber of the flexible balloon. The liquid is then withdrawn, drained, or suctioned from the chamber through the lumen of the second tubular member. During this process, the chamber of the flexible balloon or pad expands to place the flexible balloon in contact with the adjacent anatomy, i.e., the retromandibular area or the peritonsillar region. The method may further include the step of recirculating the liquid by infusing the liquid through the lumen of the first tubular member and withdrawing the liquid through the lumen of the second tubular member. The liquid may be infused using a pump at a flow rate of between about 5 mL/min and about 5 L/min, alternatively between about 100 mL/min and about 400 mL/min, alternatively between about

150 ml/min and about 200 ml/min. A drug may also be eluted from a surface of the flexible balloon.

[0030] In another embodiment, the invention provides a gas and liquid delivery system. The delivery system includes a flow meter for delivering a gas, a mixing manifold in fluid communication with the flow meter, and a reservoir containing a liquid portion and a gas portion. The gas portion of the reservoir is in fluid communication with the flow meter and the mixing manifold and the liquid portion independently communicates with the mixing manifold. The system may further comprise a flow restrictor that regulates a flow of liquid from the reservoir to the mixing manifold. The liquid may be a perfluorocarbon such as perfluorohexane or 2-methyl-perfluoropentane. The gas being delivered may be oxygen, air, or a combination thereof.

[0031] In an alternative embodiment, the invention provides a gas and liquid delivery system with the following characteristics. The delivery system includes a flow meter for delivering a gas, a mixing manifold in communication with the flow meter through a lumen of a first elongate tubular member, and a sealed reservoir containing a fluid. A lumen of a second elongate tubular member is in communication with the interior of the sealed reservoir and also with the lumen of the first elongate tubular member. The fluid from the sealed reservoir is in communication with the mixing manifold through a third elongate tubular member. The delivery system may further include a flow restrictor coupled to the third elongate tubular member capable of regulating a flow rate of fluid from the reservoir to the mixing manifold. The liquid may be a perfluorocarbon such as perfluorohexane or 2-methyl perfluoropentane. The gas being delivered may be oxygen, air, or a combination thereof.

[0032] In use, the delivery systems described above deliver gas from the flow meter to the mixing manifold and to the gas portion of the reservoir. Liquid is delivered from the liquid portion of the reservoir to the mixing manifold as a result of pressure from the gas building within the gas portion of the reservoir, thereby displacing liquid from the liquid portion of the reservoir into the mixing manifold. The method may further include the step of regulating a flow of the liquid from the liquid portion of the reservoir to the mixing manifold with a flow restrictor. The liquid and gas in the mixing manifold can then be delivered into a nasal cavity of a patient through a port in a catheter.

[0033] In an alternative embodiment of this invention, thin impermeable membranes surrounding a space may be placed over the carotid arteries externally. For example, the membranes may extend from clavicle to the ear lobe and be approximately 4 cm in width. The membranes may be cooled using a liquid perfluorocarbon, preferably with a boiling point less than 37° C., delivered cold or at room temperature. The membrane must be filled such that vapor can still escape. The membranes may be of a radiator shape to increase surface area. In addition, the membranes may have an inlet and a larger bore outlet. Adhesive may be used to stick the membranes to the neck, e.g., like an EKG patch. Alternatively, a collar with cold patches confined to the carotid region may be used. The liquid in the membranes may be cold saline, refrigerants, or perfluorocarbons with a boiling point of above or below 37° C. Additionally, a vasodilator cream may be applied behind the cooling membrane to dilate vessels maximally.

[0034] In an alternative embodiment of this invention, a thin impermeable membrane may be placed inside the oral

cavity over each carotid behind the tonsils with adhesive. The membrane may be for example, 4 cm length and 1.5 cm width. These membranes may cool in the same way as described above. The membrane may be of a radiator shape to increase surface area. In addition, the membranes may have an inlet and a larger bore outlet. The liquid in the membranes may be cold saline, refrigerants, or perfluorocarbons with a boiling point of above or below 37° C. The membrane should be sized sufficiently small so as not to obstruct the airway or induce gagging as it expands with vapors.

[0035] In another alternative embodiment, nasal prongs and/or mouthpiece may be used to circulate cold perfluorocarbon gas, for example, SF₆ jet, perfluoropropane or butane, about 1 or 2 degrees in about one hour, to rapidly cool the nasopharynx. The patient could be hyperventilated at 12 L/min, 6 L gas, 6 L oxygen mixture for a few minutes or longer with the addition of CO₂ or dead space. This embodiment may be combined with an external carotid pad, as previously described, or with a cooling helmet for additional cerebral cooling.

[0036] In another embodiment according to this invention, a nasal catheter is used to deliver a mist or spray of a nebulized liquid into the nasal cavity of a patient. In a preferred embodiment, the catheter may be a multi lumen tube inserted through the nose containing a plurality of lumens. A first lumen is dedicated to spraying liquid and/or oxygen into the nasal cavities. This may have specialized features for creating small droplets. In an alternative embodiment, the catheter may have a spray nozzle secured to the distal end of the catheter and the spray or mist may be delivered into the nasal cavity via a spray nozzle for fanning or swirling the spray or mist. A second suction tube may be inserted through a second lumen in the catheter and positioned in the esophagus of the patient for suctioning out any vapors of the nebulized liquid that enter the esophagus. The suction tube may have slits or openings along its length for communicating with the lumen of the esophagus and may be on intermittent or continuous suction for removing the vapors. The geometry allows 'flow through' cooling as the liquid is introduced in the nose and then suctioned out of the upper esophagus. Some of this liquid will evaporate and be exhaled as vapor. This phase change will draw significant energy from the body. Indirect cooling will be also obtained as some of the liquid evaporates in the spray plume, chilling the inhaled gas. In an alternative embodiment, the liquid may be pre-cooled to further facilitate cerebral cooling.

[0037] In an alternative embodiment, a specialized nasal catheter is described for the application of a nebulized liquid, preferably a perfluorocarbon (PFC), for cerebral and systemic cooling. This embodiment comprises a multi-lumen elongate member with a length operable to extend a patient's esophagus to be inserted through the nose, and into the esophagus. An inflatable external balloon is located near the distal end, which may be used to occlude the esophagus. A first lumen of the elongate member may then be used for suctioning vapor and/or liquid from the stomach. A second lumen may be exposed proximal to balloon, to allow suctioning vapor or liquid that enters the upper esophagus. In operation, the catheter is placed and the balloons inflated to occlude the respective passages. Gastric suction can be applied per clinical practice. Air (or oxygen) is introduced to the patient through the spray lumen in the nose. A PFC liquid is added to the spray lumen; this will produce a fog of droplets in the nasal cavity. Much of the PFC liquid will impact and coalesce

on the walls of the nasal cavity and associated passages. This liquid will then drain down to the throat, the majority of which will enter the esophagus where it can be suctioned through the proximal suction port and reused. Some may enter the lungs either directly as liquid or as droplets carried on the inhaled breath. In addition, a plug or balloon may be located at the entrance to the nasal cavity to prevent any retrograde flow out of the nose. In an alternate embodiment, the elongate member may be bifurcated outside the nose, with an additional prong and balloon for the other nostril.

[0038] In an alternative embodiment according to this invention, a nasal catheter may be used to deliver a spray of liquid to the nasal cavity of a patient. The nasal catheter may be placed in the nares of the patient's nose and may be angled to direct the spray outlet at the desired structures of the nose, for example, the nasal conchae. In addition, the distal end of the nasal catheter and may be designed to cause the spray to spread in a pattern which will allow the gas and liquid mixture to contact as much of the desired tissue as possible. Spreading the spray will also minimize the potential of medical trauma that could result from a high velocity stream of liquid directed at the tissue of the nasal cavity. In addition, the distal end of the catheter may be 'tipped', i.e., sealed off in a rounded fashion to provide a smooth surface to avoid damaging the sensitive nasal tissues.

[0039] A number of methods for spreading the spray pattern are contemplated. For example, the spray pattern may be formed by creating one or more holes along opposite sides of the catheter tip, which would create a broad, flat spray perpendicular to the axis of the catheter. This pattern may be further altered by changing the size, location and number of holes in the catheter. In addition, this pattern may further include a hole in the tip of the catheter to produce some additional flow in the axial direction. An alternative spray pattern may be formed by making a slit in the tip of the catheter to produce a fan shaped spray centered on the axial direction of the catheter. This pattern may be further altered by varying the width of the slit and the length the slit extends down the sides of the catheter. In addition, multiple, intersecting slits may be made in the catheter tip. Another alternative spray pattern may be formed by making a straight or curved cut along opposite sides of the catheter wall. The skewed cut may extend from and include a portion of the tip. This configuration will produce a wide 'fan' shaped spray covering a broad angle from the perpendicular to the axial direction of the catheter. In addition, any of the above described patterns could be combined to create additional spray patterns for the nasal catheter.

[0040] In an alternative embodiment, the proximal end of the nasal catheter may be designed to further include one or more expandable members mounted on the distal end. In use, the nasal catheter may be inserted into one of the patient's nostrils and positioned in the posterior aspect of the nasal cavity, proximal to the opening to the nasopharynx. Once positioned in posterior aspect of the nasal cavity, the expandable member may be expanded to conform to the posterior aspect of the nasal cavity and form a seal isolating the nasal cavity from the nasopharynx and the rest of the patient's airways in order to prevent non-vaporized liquid from leaking into the pharynx. Once isolated, the spray of liquid may be delivered into one of the patient's nostrils and circulated through the nasal cavity to allow for rapid cooling of the patient's head. The non-vaporized liquid may then be allowed to run out the patient's other nostril. In an alternative embodi-

ment, the elongate tubular member may further comprise a second lumen having a port proximal to the expandable member whereby the excess liquid may be suctioned from the patient's nasal cavity. This suctioned liquid may be continuously recycled for a successive delivery into the patient's nasal cavity without interrupting delivery.

[0041] At the proximal end, the nasal catheter may be attached to a liquid delivery system whereby the liquid and the gas are delivered to the catheter through their own tubes and mixed at the point of administration to the patient, rather than prior to use. This ensures that even an unstable spray can be delivered to the desired region. Furthermore, since the liquid begins to evaporate immediately upon contact with the gas, mixing at the point of use in the patient will ensure efficient use of all available cooling. In an embodiment according to this invention, the mixing device may be a mixing block, machined from metal or plastic or molded from plastic, including at least two input flow channels and a single output flow channel. The two input flow channels may be connected to two separate tubes containing a liquid and a compressed gas. These input channels may then be joined in the mixing block so that the liquid and gas carried by the input tubes will be combined, after which the combined liquid/gas mixture may then flow through the output channel. The nasal catheter may be attached to the output channel for delivery of the combined liquid/gas mixture to the patient's nasal cavity.

[0042] In an alternative embodiment according to this invention, a dual lumen mixing catheter may be used to individually transport the liquid and the gas to a nasal catheter. The mixing catheter may be constructed as a single ended device, or alternatively made into a loop similar to the standard nasal cannula for oxygen therapy. The loop configuration aids in placement on the patient, as it may be routed over and behind the ears to hold it in place. In addition, in an alternative embodiment where two nasal catheters, i.e., one for each nostril, are connected to the mixing catheter, the loop configuration also helps ensure equal flow to both nasal catheters.

[0043] The dual lumen tubing, comprising lower and upper lumens, may be attached to the nasal catheter via a connecting tube. The connecting tube is a hollow, open ended tube with an outer diameter sized to fit tightly in the inner diameter of the nasal catheter. The connecting tube may be made from metal 'hypodermic' tubing or a suitable plastic. One end of the connecting tube resides in the lower lumen of the dual lumen tubing and while the other end of the connecting tube is positioned in the nasal catheter, thus placing the nasal catheter in fluid communication with the lower lumen of the mixing catheter. In addition, a small hole may be drilled in the wall of the connecting tube for placing the connecting tube in fluid communication with the upper lumen of the dual lumen tubing. In use, the gas is supplied through the lower lumen, i.e., the gas channel, of the dual lumen tubing. The gas flows through the connecting tube into the nasal catheter. A liquid is supplied through the upper lumen, i.e., liquid channel, of the dual lumen tubing and flows through the small hole into the connecting tube. At this point, the gas is moving at a high velocity and the liquid experiences high shear forces, breaking the liquid stream into small droplets and creating a nebulized liquid for delivery via the nasal catheter. The inner diameter of the connecting tube and the size of the fluid hole are important parameters and may be varied to vary the size of the liquid droplets and to optimize the spray pattern of the nasal catheter, for example the diameter of the connecting

tube may vary between 0.050-0.150 inches and the diameter of the fluid hole may vary between 0.010-0.090 inches. In addition, a second fluid hole may be added to further optimize the spray pattern.

[0044] In an alternative embodiment according to this invention, the mixing of the liquid and gas occurs in the distal region of the nasal catheter, proximal to the spray nozzle. Here, the lower lumen of the dual lumen tubing is the liquid channel and the upper lumen is the gas delivery channel. The lower lumen is connected to an open ended liquid delivery tube extending perpendicularly from an outlet port in the outer wall of the upper lumen. When the nasal catheter is secured to the outlet port in the upper lumen, the liquid delivery tube will extend coaxially inside the lumen of the nasal catheter. The liquid delivery tube is sized to extend to the distal region of the nasal catheter and has a diameter smaller than the inner diameter of the nasal catheter. In use, the liquid flows through from the liquid channel of the dual lumen tubing through the liquid delivery tube to the distal region of the nasal catheter at a rate of approximately 25-200 ml/min, while the gas flows into the lumen of the nasal catheter at the proximal end by flowing through the outlet port and in the annular space between the liquid delivery tube and the inside diameter of the nasal catheter. When the liquid and gas are combined at the end of the liquid tube, turbulence and other flow effects, for example Bernoulli pressure, cause the fluid to be broken up into small droplets. The advantages of this embodiment are that less pressure is required to drive the liquid which may aid in matching liquid and gas flow rates.

[0045] In an alternative embodiment according to this invention, the mixing catheter may further include a second connecting tube or a second outlet port and liquid delivery tube combination so that a second nasal catheter, for the patient's second nostril, may be connected to the mixing catheter. When two nasal catheters are used, the connecting tubes or outlet ports may be spaced apart an appropriate distance for the nares of the patient. In addition, the length of the nasal catheters may be varied to accommodate for varying nasal cavity size in order to be able to target specific tissues in the nasal cavity.

[0046] In an alternative embodiment according to this invention, the mixing catheter may further include a liquid delivery system for using the pressure from the compressed gas source to deliver the liquid to the nasal catheter. In this device, both the gas and the liquid are delivered strictly using the pressure from the compressed gas source without the use of pumps or electronics. Here, an inlet valve is connected to a compressed gas source, typically oxygen or an oxygen and air mixture regulated to about 50 psi. The inlet valve blocks or allows the pressurized gas into the rest of the system. When the inlet valve is in the "blocked" position, the valve also may vent pressure from the system. When the inlet valve is in the "allow" position, the gas flow splits in two directions, one flow is connected to the gas flow channel of the dual lumen tubing and the other flow is connected to a fluid reservoir container which is designed to hold the desired dose of a liquid. The fluid control reservoir is rated to withstand the pressure of the compressed gas, for example the fluid control reservoir may be a poly ethylene terephthalate (PET) container tested to pressures in excess of 150 psi. In addition, a burst disk or relief valve, set at a value exceeding the expected operating pressure, for example 60 psi, alternatively 70 psi, alternatively 80 psi, alternatively 90 psi may be added to the fluid reservoir container as a safety means for venting gas in

the event of over pressurization. Alternatively, an extra layer of material, such as a flexible membrane, mesh bag, etc may be attached to the fluid reservoir container to contain the pieces of the container in the event of a container rupture.

[0047] When the pressurized gas flows into the fluid reservoir, the fluid is routed through an outlet port in the reservoir that is in fluid communication with the liquid channel of the dual lumen tubing. In addition, the outlet port may include a fluid flow controlling device, such as a needle type valve or a variable diameter aperture to adjust the flow rate of fluid into the liquid channel of the dual lumen tubing. In addition, the flow channel to the gas channel of the dual lumen tubing may also include a flow controlling device such as a needle type valve or a variable diameter aperture to adjust the flow rate of gas into the gas channel of the dual lumen tubing. The flow control valves of the gas and liquid channels may be independently controlled by the operator to allow full flexibility in varying the gas and/or liquid flow to optimize the gas/liquid flow ratio. The gas and liquid flow control devices may have fixed orifices which produce a known constant flow for the gas and the liquid, or alternatively, the control devices may include a selector which would allow the operator to choose one of several sets of orifices in order to provide the operator with a number of choices for the flow, for example low flow, medium flow, high flow, induction and maintenance flow rates. Here, each set point on the selector would use a predetermined orifice for the gas flow and a matched orifice for the liquid such that the gas/liquid flow rates and ratios would be optimized for each condition. In an alternative embodiment, the flow rate generated by the fixed orifices may be further altered while maintaining the constant gas/liquid ratio, by using pressure regulator to regulate the input pressure of the gas source. The pressure regulator may also allow better control of the gas pressure delivered to the liquid delivery system and to the nasal catheter.

[0048] In addition, liquid and gas flow meters may be used in the liquid and gas flow channels to further monitor and regulate the liquid and gas flow rates. The flow meter may be any standard flow technology such as turbines, paddlewheels, variable area Rota meters or mass flow meters. In addition, in line filters may be used for both the gas and liquid channels to prevent particulate matter from being introduced to the patient.

[0049] In an alternative embodiment, a nasal catheter may be designed to include an elongate tubular member extending into the patient's nasopharynx and further including having one or more parallel lumens and one or more expandable members mounted on the distal end. In use, the nasal catheter may be inserted into one of the patient's nostrils and positioned in the posterior aspect of the nasal cavity, proximal to the opening to the nasopharynx. Once positioned in posterior aspect of the nasal cavity, the one or more expandable members may be expanded to conform to the posterior aspect of the nasal cavity and form a seal isolating the nasal cavity from the nasopharynx and the rest of the patient's airways in order to prevent liquid from leaking into the throat. Once isolated, a cooled liquid, for example cold saline, may be delivered into one of the patient's nostrils via a first lumen and circulated through the nasal cavity to allow for rapid cooling of the patient's head. The saline may then be allowed to run out the patient's other nostril.

[0050] In an alternative embodiment, the elongate tubular member may further comprise a second lumen having a port proximal to the expandable member whereby the excess liq-

uid may be suctioned from the patient's nasal cavity. In addition, this suctioned liquid may be recycled for successive delivery into the patient's nasal cavity. In addition, the elongate tubular member may further comprise a set of two expandable members located on the proximal end to occlude the nostrils and thus further isolate the nasal cavity and prevent fluid from leaking out of the patient's nostrils. In this embodiment, the elongate member may further include a third lumen extending between the distal and proximal ends of the elongate member and having an opening at the distal and proximal ends and for providing a breathing passage through the nasal cavity while it is occluded by the expandable members. In use, the catheter may be inserted into one of the patient's nostrils and positioned in the posterior aspect of the nasal cavity, proximal to the opening to the nasopharynx. Once positioned in posterior aspect of the nasal cavity, the one or more distal expandable members may be expanded to conform to the posterior aspect of the nasal cavity and form a seal isolating the nasal cavity from the nasopharynx while the two proximal expandable members may be expanded to occlude the patient's nostrils and isolate the nasal cavity. Once isolated, a cold liquid, for example cold saline or a PFC, may be delivered to the nasal cavity via a delivery lumen and suctioned out of the nasal cavity via a suction lumen. The nasal cavity is completely isolated so none of the liquid may leak to the throat or run out the patient's nostrils however the suction lumen allows used saline to be removed from the nasal cavity so that cold saline can be continuously introduced. Use of the distal and proximal expandable members to isolate the nasal cavity, however, may cause a pressure build up in the nasal cavity. To prevent such a pressure build-up, the expandable members may be made of a somewhat porous material such as cork, wool, cotton or any other slightly porous material known to those skilled in the art. The slightly porous material may prevent pressure build up while still preventing most fluid leakage. In addition, the third lumen with openings on the proximal and distal ends of the elongate tubular member permits the patient to continue breathing through his nose even while the nasal cavity is isolated for treatment.

[0051] In an alternative embodiment, anesthetics, such as lidocaine or marcaine, vasodilators, such as beta blockers, Nitric Oxide or nitroglycerin, neuroprotective agents and any other drugs for systemic absorption, such as insulin, may also be delivered to the nasal cavity with this device. It is further contemplated that these drugs may be delivered unaccompanied or may be delivered in addition to a cooling agent to facilitate cerebral cooling.

[0052] In an alternative embodiment, a conductive gel may be delivered to the isolated nasal cavity via the delivery lumen. Once the gel has been delivered to the nasal cavity, a conductive device that conducts heat may be inserted to the nasal cavity via either the delivery lumen or a fourth lumen to cool the conductive gel in place. The conductive device could be a metal, such as copper. Alternatively, the conductive device may be a probe through which a chilled fluid is circulated, a probe in which a fluid undergoes a phase change, or a heat pipe, which is a sealed system utilizing an internal fluid that boils on one end and condenses on the other end in order to transmit heat. In the case of the probe with the fluid undergoing a phase change, the fluid may have a boiling point below body temperature, such as Freon. Additionally, an external cooling source, such as a refrigeration system, ther-

moelectric heat pump, ice bath, or evaporative cooler, will be connected to the proximal end of the probe.

[0053] In an alternative embodiment, a second nasal catheter comprising an elongate tubular member with an expandable member mounted on the distal end may be inserted in the patient's second nostril. In this embodiment, the balloons may be positioned on either side of the nasal cavity before the septum and expanded to isolate the nasal cavity from the rest of the patient's airways.

[0054] The compositions of the invention include liquids having a boiling point of 38-300° C., more preferably a boiling point of 38-200° C., more preferably a boiling point of 60-150° C., more preferably a boiling point of 70-125° C., more preferably a boiling point of 75-110° C., more preferably a boiling point of 60-70° C. Compounds having suitable characteristics for use herein include hydrocarbons, fluorocarbons, perfluorocarbons, and perfluorohydrocarbons. Saline is another example of a substance having suitable characteristics for use herein. As used in this specification, the terms "fluorocarbon," "perfluorocarbon," and "perfluorohydrocarbon" are synonymous. In addition to containing carbon and fluorine, these compounds may also contain other atoms. In one embodiment, the compounds could contain a heteroatom, such as nitrogen, oxygen, or sulfur, or a halogen, such as bromine or chlorine. These compounds may be linear, branched, or cyclic, saturated or unsaturated, or any combination thereof.

[0055] In another embodiment, the compounds are highly fluorinated compounds, which are compounds containing at least three fluorine atoms. These highly fluorinated compounds may also contain other atoms besides carbon and fluorine. These other atoms include, but are not limited to, hydrogen; heteroatoms such as oxygen, nitrogen, and sulfur; and halogens such as bromine or chlorine. In one embodiment, the number of the atoms that are not carbon or fluorine comprise a minority of the total number of atoms in the compound. These highly fluorinated compounds may be linear, branched, or cyclic, saturated or unsaturated, or any combination thereof. Examples of these compounds include, but are not limited to, C_4F_9Br (b.p. 43° C.), $CF_3CF(CF_3)CF=CF_2$ (b.p. 51° C.), or $CF_3CF(CF_3)CH=CH_2$.

[0056] In another embodiment, the compounds are hydrofluorocarbons, which are compounds where the number of hydrogen atoms exceeds the number of fluorine atoms. These hydrofluorocarbons may also contain other atoms besides hydrogen, carbon, and fluorine. These other atoms include, but are not limited to, heteroatoms such as oxygen, nitrogen, and sulfur and halogens such as chlorine and bromine. For example, hydrofluorocarbons include, but are not limited to, hydrochlorofluorocarbons, more specifically, hydrochlorofluoroalkanes. In one embodiment, the number of the atoms other than carbon and fluorine comprise a minority of the total number of atoms in the compound. These hydrofluorocarbons may be linear, branched, or cyclic, saturated or unsaturated, or any combination thereof.

[0057] A mixture of two or more highly fluorinated compounds, hydrofluorocarbons, light fluorocarbons, hydrocarbons, fluorocarbons, perfluorocarbons, perfluorohydrocarbons, or any of the above-mentioned compounds may also be used. The mixture may contain any of the previously mentioned compounds in different phases (e.g., one gas, one liquid). The mixture has a boiling point above 37° C., even though any individual component of the mixture may have a boiling point below 37° C.

[0058] Light fluorocarbons are fluorocarbons that have a boiling point below 37° C. These light fluorocarbons may also contain other atoms besides carbon, and fluorine. These other atoms include, but are not limited to, hydrogen; heteroatoms such as oxygen, nitrogen, and sulfur; and halogens such as chlorine and bromine. For example, light fluorocarbons include, but are not limited to perfluorobutane and perfluoropentane. In one embodiment, the number of the atoms other than carbon and fluorine comprise a minority of the total number of atoms in the compound. These light fluorocarbons may be linear, branched, or cyclic, saturated or unsaturated, or any combination thereof.

[0059] In certain methods, a liquid having a boiling point of 38-300° C., more preferably having a boiling point of 38-200° C., more preferably having a boiling point of 38-150° C., is selected. The liquid is nebulized to form a mist. The droplets preferably range in size from 0.1-100 microns, more preferably 1-5 microns, more preferably 2-4 microns. The mist is optionally cooled below body temperature and delivered to the airway of a patient so that the patient inhales the mist. Inhalation of the mist causes systemic cooling by heat transfer from the lungs to the cooler mist and/or by evaporative heat loss as the mist evaporates. The liquid is delivered at a rate to achieve 3-4° C. cerebral cooling in one hour or alternatively 2° C. body cooling in one hour. The liquid delivery rate preferably ranges from 10-500 cc/min, more preferably between 50-350 cc/min, more preferably between 150-220 cc/min, more preferably about 175 cc/min. The administration of the liquid is continued until the systemic temperature is reduced to 35° C. or below, more preferably to 34° C. or below, more preferably to 33° C. or below. The rate of cooling can be adjusted by varying the temperature of the inhaled, the concentration of the responsible compound or compound mixture, the rate of delivery, the particle size, and the percentage of each compound in the mixture.

[0060] Nitric oxide or adrenergic agents, such as adrenaline (epinephrine) or albuterol, may be added in minute doses to the compositions described in any of the previously described embodiments. The NO or other agent is inhaled and acts as a potent nasal vasodilator, which improves the rate of action of the cooling mist and counteracts nasal vasoconstriction caused by administering cold substances to the nasal cavity. The NO may be included in an amount of about 2 to about 80 parts per million, in other cases in an amount of about 3 to about 20 parts per million, in other cases in an amount of about 4 to about 10 parts per million, in other cases in an amount of about 5 to about 8 parts per million, in other cases in an amount of about 5 parts per million.

[0061] In other methods, administration of cold mists will occur in cycles with intervening cycles of administering another gas, preferably a cold dry gas such as dry air or dry heliox, e.g., a mixture of helium and oxygen. With continuous administration of perfluorocarbon mist, the gaseous phase in the nasal cavity may become saturated with gaseous PFC, thereby slowing the rate of evaporative heat loss. In order to accelerate the rate of evaporative heat loss, it may be desired to periodically purge nasal cavity of perfluorocarbon. This can be done by cycling administration of cold mists with administering another gas, preferably a dry gas such as dry air or dry heliox.

[0062] Where cycling is desired, it is recommended that the cycles occur for about 3 seconds or more, in other cases for about 30 seconds or more, in other cases for about one minute or more, in other cases for about two minutes or more, in other

cases for about five minutes or more, in other cases for about ten minutes or more, in other cases for about 30 minutes or more. The intervening cycle of dry gas may last for an equal period (e.g., about 3 seconds of cold mist followed by about 3 seconds of dry gas, about 30 seconds of cold mist followed by about 30 seconds of dry gas, about one minute of cold mist followed by about one minute of dry gas, about two minutes of cold mist followed by about two minutes of dry gas, about five minutes of cold mist followed by about five minutes of dry gas, about ten minutes of cold mist followed by about ten minutes of dry gas, about 30 minutes of cold mist followed by about 30 minutes of dry gas, or for a shorter or longer period (about ten minutes of cold mist followed by about two minutes of dry gas).

[0063] In certain methods, a liquid having a boiling point of 38-300° C. is selected. The liquid is nebulized to form a mist. The droplets preferably range in size from 1-5 microns. The mist is delivered to the nasal and/or oral cavities of a patient so that the mist causes cerebral cooling by heat transfer to the cooler mist and/or by evaporative heat loss. In addition indirect hematogenous cooling occurs through the carotids as they pass by the oropharynx and through the Circle of Willis which lies millimeters away from the pharynx. The administration of the liquid is continued until the cerebral temperature is reduced to 35° C. or below, more preferably to 34° C. or below, more preferably to 33° C. or below. In certain methods, the administration of the liquid may be continued to provide for systemic cooling as well as cerebral cooling. In certain methods, the liquid may be cooled to below body temperature before delivery. The mist droplets may range in size from 1-5 microns.

BRIEF DESCRIPTION OF THE DRAWINGS

[0064] FIG. 1 illustrates an embodiment of a device having multiple ports for delivering a liquid inserted into the nasopharyngeal cavity according to the present invention for non-invasive cerebral and systemic cooling.

[0065] FIG. 2 illustrates an embodiment of a device having multiple ports for delivering a liquid to the nasopharyngeal cavity according to the present invention for non-invasive cerebral and systemic cooling.

[0066] FIG. 3 illustrates an embodiment of a device having multiple ports for delivering a liquid to the nasopharyngeal cavity according to the present invention for non-invasive cerebral and systemic cooling.

[0067] FIG. 4 illustrates a cross-section of a nasal catheter having a plurality of lumens for separately transporting a liquid and a compressed gas according to the present invention.

[0068] FIG. 5 illustrates a cross-section of a nasal catheter having a plurality of ports for separately nebulizing a liquid and delivering a nebulized liquid spray to the nasal cavity according to the present invention.

[0069] FIG. 6A illustrates a cross-section of an alternative embodiment of nasal catheter having a plurality of lumens for separately transporting a liquid and a compressed gas according to the present invention.

[0070] FIG. 6B illustrates a cross-section of an alternative embodiment of a nasal catheter having a plurality of ports for nebulizing a liquid and delivering a nebulized liquid spray to the nasal cavity according to the present invention.

[0071] FIG. 7A illustrates a cross-section of an alternative embodiment of nasal catheter having a plurality of lumens for separately transporting a liquid and a compressed gas according to the present invention.

[0072] FIG. 7B illustrates a cross-section of an alternative embodiment of a nasal catheter having a plurality of ports for nebulizing a liquid and delivering a nebulized liquid spray to the nasal cavity according to the present invention.

[0073] FIG. 7C illustrates a cross-section of an alternative embodiment of a nasal catheter having a plurality of ports for nebulizing a liquid and delivering a nebulized liquid spray to the nasal cavity according to the present invention.

[0074] FIG. 7D illustrates a cross-section of an alternative embodiment of a nasal catheter having a plurality of ports for nebulizing a liquid and delivering a nebulized liquid spray to the nasal cavity according to the present invention.

[0075] FIG. 8 illustrates a cross-section of an alternative embodiment of nasal catheter having a plurality of lumens for separately transporting a liquid and a compressed gas according to the present invention.

[0076] FIG. 9 is a table of parameters and results for cerebral cooling trials performed wherein the compressed gas flow rate was maintained while the liquid flow rates were varied.

[0077] FIG. 10 is a graph of the nasal temperatures against liquid flow rate for the different compressed gas flow rates listed in FIG. 9.

[0078] FIG. 11 is a graph illustrating the gradient between cerebral and systemic cooling achieved using a method according to the present invention in a human.

[0079] FIG. 12 is a graph illustrating the gradient between cerebral and systemic cooling achieved using a method according to the present invention in a human.

[0080] FIG. 13 is a graph illustrating the gradient between cerebral and systemic cooling achieved using a method according to the present invention in a human.

[0081] FIG. 14 is a graph illustrating the gradient between cerebral and systemic cooling achieved using a method according to the present invention in a human.

[0082] FIG. 15 is a graph illustrating the gradient between cerebral and systemic cooling achieved using a method according to the present invention in a human.

[0083] FIG. 16 is a graph illustrating the gradient between cerebral and systemic cooling achieved using a method according to the present invention in a human.

[0084] FIG. 17 is a graph illustrating the gradient between cerebral and systemic cooling achieved using a method according to the present invention in a human.

[0085] FIG. 18 is a graph illustrating the gradient between mean cerebral and mean systemic cooling achieved using a method according to the present invention.

[0086] FIG. 19 is a graph illustrating the cooling rates achieved using a method according to the present invention for various delivery rates.

[0087] FIG. 20 illustrates an embodiment of a device having a cooling helmet or cap with attached nasal prongs according to the present invention for non-invasive cerebral and systemic cooling.

[0088] FIG. 21 illustrates an embodiment of a device having a mask with a nasal catheter inserted therethrough.

[0089] FIG. 22A illustrates an embodiment of a device having a flexible balloon mounted on an elongate tubular member for insertion into the nasal cavity.

[0090] FIG. 22B illustrates the device of FIG. 22A inserted into a nasal cavity.

[0091] FIG. 23A illustrates an alternative embodiment of a flexible balloon device for insertion into a nasal cavity.

[0092] FIG. 23B illustrates the device of FIG. 23A inserted into a nasal cavity.

[0093] FIG. 24 illustrates an embodiment of a device having a flexible balloon mounted on an elongate tubular member inserted down the esophagus.

[0094] FIG. 25A illustrates a modified laryngeal mask.

[0095] FIG. 25B illustrates an alternative embodiment of a modified laryngeal mask.

[0096] FIG. 25C illustrates use of the device of FIG. 25A.

[0097] FIG. 26 illustrates an embodiment of a flexible balloon device for insertion into the oral cavity.

[0098] FIG. 27 illustrates an embodiment of a device having a flexible balloon and a cold probe for insertion into the nasal cavity.

[0099] FIG. 28A illustrates an alternative embodiment of a device having a flexible balloon and a cold probe for insertion into the nasal cavity.

[0100] FIG. 28B illustrates the device of FIG. 28A inserted into a nasal cavity.

[0101] FIG. 29 illustrates an embodiment of a device having a flexible balloon mounted on a branched elongate tubular member for insertion into the nasal cavity.

[0102] FIG. 30 illustrates an alternative balloon shape.

[0103] FIG. 31 illustrates a fluid and gas delivery system.

[0104] FIG. 32A illustrates an embodiment of a device having an expandable member constructed according to the present invention for non-invasive cerebral and systemic cooling.

[0105] FIG. 32B illustrates an embodiment of a device having an esophageal suction tube constructed according to the present invention.

[0106] FIG. 33 illustrates an embodiment of a device having an esophageal suction tube and a gastric suction tube constructed according to the present invention.

[0107] FIG. 34 illustrates an embodiment of a device having a nasal plug constructed according to the present invention.

[0108] FIG. 35 illustrates an alternative embodiment of a device having an expandable member constructed according to the present invention for non-invasive cerebral and systemic cooling.

[0109] FIG. 36 illustrates an embodiment of a device for delivering a liquid to the nasal and oral cavity according to the present invention.

[0110] FIG. 37 is a table of experimental data from cerebral cooling trials performed wherein the cooling liquid used and the flow rate were varied.

[0111] FIG. 38 is a graph of is of brain temperatures against time for different runs listed in FIG. 37.

[0112] FIG. 39 illustrates an embodiment of a device having a spray nozzle constructed according to the present invention for non-invasive cerebral and systemic cooling via the nasal cavity.

[0113] FIG. 40 illustrates an embodiment of a delivery system constructed according to the present invention for delivery of a liquid and gas for non-invasive cerebral and systemic cooling of the nasal cavity.

[0114] FIG. 41 illustrates an embodiment of a connecting tube for connecting the nasal catheter to the liquid delivery system constructed according to the present invention.

[0115] FIG. 42 illustrates an embodiment of a connecting tube for connecting the nasal catheter to the liquid delivery system constructed according to the present invention.

[0116] FIG. 43A illustrates an embodiment of a spray nozzle for use with the present invention.

[0117] FIG. 43B illustrates an embodiment of a spray nozzle for use with the present invention.

[0118] FIG. 43C illustrates an embodiment of a spray nozzle for use with the present invention.

[0119] FIG. 44 illustrates a mixing block for mixing the liquid and gas at the point of administration constructed according to the present invention.

[0120] FIG. 45 illustrates a liquid delivery system for delivering the liquid to the point of administration constructed according to the present invention.

[0121] FIG. 46 illustrates an embodiment of a device having an expandable member constructed according to the present invention for non-invasive cerebral and systemic cooling via the nasal cavity.

[0122] FIG. 47 illustrates an embodiment of a device having proximal and distal expandable members constructed according to the present invention for non-invasive cerebral and systemic cooling via the nasal cavity.

[0123] FIG. 48 illustrates an embodiment of a device having proximal and distal expandable members constructed according to the present invention for non-invasive cerebral and systemic cooling via the nasal cavity.

DETAILED DESCRIPTION

Evaporative Cooling in the Nasal Cavity

[0124] FIGS. 1-3 illustrate nasal catheter 10 with multiple delivery ports 12a-m for non-invasive cerebral and systemic cooling of the nasal cavity. Nasal catheter 10 is operably sized to extend through the patient's nasal cavity and into the nasal pharynx and has a plurality of lumens 14 and 16a-b extending between the proximal and distal ends of catheter 10 for separately delivering a liquid and a compressed gas. Nasal catheter 10 also has rounded sealed tip 22 on the distal end, which seals the distal end of lumens 14 and 16a-b and provides a smooth surface to avoid damaging sensitive tissues. FIGS. 4-7 depict several possible designs for the lumens of nasal catheter 10. FIG. 4 shows catheter 10 with a large, circular central lumen 14 that may be used for transporting the compressed gas through catheter 10 while one or more smaller lumens 16a-b may be used for transporting the liquid through catheter 10. In FIGS. 6-8, more complex, geometric extruded tubes are used to simplify the mixing process at each delivery port. In FIGS. 6A-B, square central lumen 64 is provided for transporting the compressed gas through the catheter while the liquid may be transported in four outer sections 66a-d. FIGS. 7A-D depict an alternative embodiment where the gas lumen is a central geometric shape 74 and the four outer sections 76a-d form the channels for transporting the liquid. In an alternative embodiment, additional lumens (not shown) may be provided, for example, to permit inflation of an expandable member located on the distal end of the catheter or to permit suction of the non-evaporated liquid from the nasal cavity.

[0125] As shown in FIG. 3, a plurality of ports 12a-m are located along the outer wall of catheter 10. These ports 12a-m are spaced apart longitudinally and axially along the outer walls of catheter 10 and are in fluid communication with lumens 14 and 16a-b transporting the liquid and compressed

gas through catheter 10. For example, there may be about 10-40 delivery ports distributed around the circumference of the catheter and spaced apart to cover the distance from about 3 cm to about 12 cm along the length of catheter 10. In use, when catheter 10 is placed in the nasal cavity of a patient, this distribution would provide full coverage of the nasal cavity. Furthermore, each delivery port will be designed so that the liquid and gas flowing through the catheter lumens will be combined near the delivery port and the liquid will then be nebulized just prior to entering the nasal cavity. As shown in FIG. 5, each of ports 12a-m is formed by drilling mixing channel 18 in the outer wall of nasal catheter 10 connecting to central lumen 14 transporting the compressed gas. In addition, separate liquid connecting tubes 20 are formed in the outer wall of catheter 10 to connect liquid lumens 16a-b with each of mixing channels 18 drilled between ports 12 a-b and compressed gas lumen 14. This provides for the ability to separately nebulize the liquid into a spray at each delivery port. Specifically, mixing channels 18 provide for gas flow outward from central gas lumen 14 while liquid connecting tubes 20 permit addition of the liquid to the gas stream in channel 18. At this point, the gas is moving at a high velocity and the liquid experiences high shear forces, breaking the liquid stream into small droplets and creating a nebulized liquid for delivery via ports 12a-b. The inner diameter of connecting tubes 20 and the shape and size of the ports 12a-b are important parameters and may be altered to vary the size of the liquid droplets and to optimize the spray pattern of delivery ports 12a-b.

[0126] FIGS. 6A-B and 7A-D depict alternative configurations for the liquid and gas channels within the nasal catheter and delivery ports on the outer walls of the catheter that may provide for easier mixing of the liquid and compressed gas at the delivery port. In FIGS. 6A-B, the nasal catheter is formed of a length of extruded tubing with interior side walls 63a-d creating a central square lumen 64 in which the compressed gas may be transported and four separate outer channels 66a-d in which the liquid may be transported. Here, when mixing channel 68 is drilled through the outer wall of the catheter at one of the corners where two of side walls 63a-b of the central lumen 64 connect with the outer wall of the catheter, openings 60a and 60b are created in each of the adjacent interior channels 66a-b through which liquid can enter the gas stream flowing through mixing channel 68. This design simplifies the construction of the device by eliminating the need for a separate connecting tube to connect the liquid lumens with the mixing channel. Moreover, the size of mixing channels 60a-b may be altered to provide for a desired liquid flow rate by adjusting the diameter of mixing channel 68. FIGS. 7A-D depict an alternative embodiment of a nasal catheter with a shaped central lumen 74 for transporting the compressed gas surrounded by four outer channels 76a-d for transporting the liquid. Delivery ports 72 are created by making skyved cuts 73 in the outer wall of the catheter, which creates aperture 77 from the gas lumen 74 and openings 75a-b into the outer channels 76a-d transporting the liquid from which the liquid can enter into the gas stream. As depicted in FIG. 7B-D, the skyved cuts may be rectangular 73, circular 78, or V-shaped 79, and may be of varying sizes to affect both the velocity of the nebulized liquid, flow rate, and size of the spray particles.

[0127] In another alternative embodiment, depicted in FIG. 8, central lumen 84 may be used to transport the liquid, while four outer channels 86a-d are used to transport the com-

pressed gas. Delivery port **82** is created by making a skyved cut in the outer wall of the catheter at the junction of the central lumen **84** and two adjacent liquid channels **86a-d**. The skyved cut provides an aperture through which the compressed gas from outer gas channels **86a-d** can escape and also creates central slit **85** in fluid communication with central lumen **84** for introducing the liquid from central lumen **84** into the gas stream. In addition to reducing the manufacturing complexity by eliminating the need for a separate channel between the liquid and gas lumens, this may be advantageous for providing a wider dispersion of flow from each delivery port **82**.

[0128] The liquids used with this catheter include liquids having a boiling point of about 38-300° C., more preferably a boiling point of about 38-200° C., more preferably a boiling point of about 60-150° C., more preferably a boiling point of about 70-125° C., more preferably a boiling point of about 75-110° C., more preferably a boiling point of about 60-70° C. Compounds having suitable characteristics for use herein include hydrocarbons, fluorocarbons, perfluorocarbons, and perfluorohydrocarbons. Saline is another example of a substance having suitable characteristics for use herein. As used in this specification, the terms “fluorocarbon,” “perfluorocarbon,” and “perfluorohydrocarbon” are synonymous. In addition to containing carbon and fluorine, these compounds may also contain other atoms. In one embodiment, the compounds could contain a heteroatom, such as nitrogen, oxygen, sulfur, or a halogen, such as bromine or chlorine. These compounds may be linear, branched, or cyclic, saturated or unsaturated, or any combination thereof. Exemplary perfluorocarbons include perfluoropropane, perfluorobutane, perfluoropentane, 2-methyl-perfluoropentane, perfluorohexane, perfluorohexane, and perfluorooctane.

[0129] The liquids delivered through the catheter (single or multi-lumen) may also comprise a humidifier. Alternatively, the humidifier may be delivered separately through the catheter or using an alternative delivery device. When used in conjunction with the cooling liquid, the humidifier would have to be cooled or else it would counteract the cooling effect of the other liquid. Where the humidifier was used independently for humidification, it could also be warmed. The humidifiers may be delivered through the same ports in the catheter as the cooling liquid. Alternatively, a different lumen and/or port in the catheter may be used to deliver the humidifier. The purpose of the humidification is to prevent the sensation of dryness, the crusting and trauma that could result from the dryness, the nasal congestion and mucous production that could result from dryness imparted by the high gas flow rates or from the evaporation of the liquid (e.g., PFC). The congestion and mucous production reduce the effectiveness of the cooling by limiting the cavity in which the evaporation occurs and by directly blocking holes in the catheter. This phenomenon may account for rapid initial cooling rates observed, followed by slower cooling rates beyond the first 20 to 30 minutes.

[0130] The humidifier may be, but is not limited to isotonic saline, or water. Where water is used as the humidifier, the quantity needed to be added for full saturation is about 41 micrograms/L of gas. Alternative nasal inhalers, such as but not limited to, ephedrine, pseudoephedrine (e.g., Afrin), antihistamines, ipratropium (e.g., Atrovent), and anticholinergics, may also be used to saturate the air in the nasal cavity.

[0131] The gases used with the catheter include any gas capable of evaporating the liquid. The gas can include, but is not limited to, nitrogen, air, oxygen, argon, or mixtures thereof.

[0132] In use, as seen in FIG. 1, this catheter is intended to be placed through the patient's nostrils and extend through the narices of the nose to the nasopharyngeal region of the nasal cavity. The length of catheter **10**, which extends to the nasal pharyngeal region of the nasal cavity and multiple ports **12a-m** located longitudinally and axially along the outer wall of the catheter enable catheter **10** to disperse the liquid spray perpendicular to the longitudinal axis of catheter **10** and over the entire nasal cavity region. This is in contrast to simply directing the spray through a single spray nozzle at a catheter tip, which would have the spray limited to a particular area along the longitudinal axis of catheter. This distinction is critical in that dispersing the spray over a larger region permits greater cooling through evaporative heat loss.

[0133] In addition, the ability to nebulize the liquid at each delivery port ensures that the distribution of varying sizes of liquid particles will be uniform throughout the nasal cavity. Specifically, when a liquid is nebulized, a spray with liquid particles of various sizes is created. If the liquid was nebulized at the proximal end of the nasal catheter or outside of the catheter and then transported as a nebulized liquid spray through the catheter lumen to the multiple delivery ports, the smaller liquid particles would flow through the proximal delivery ports while the larger liquid particles would be carried to the distal end of the tube before being delivered to the nasal cavity via one of the delivery ports near the distal end of the nasal catheter. This would result in an uneven distribution of the liquid particles within the nasal cavity. Conversely, when the liquid is transported through the nasal catheter and nebulized separately at each delivery port just prior to delivery, the size distribution of liquid particles distributed at any given point in the nasal cavity is uniform. This is critical because an even distribution of the varying sized liquid particles provides for better evaporation of the liquid spray, which results in better cooling through evaporative heat loss and is more tolerable to the patient. Furthermore, since the liquid begins to evaporate immediately upon contact with the gas, mixing at the point of use in the patient will ensure efficient use of all available cooling.

[0134] The liquid flow rate is also a critical factor for cerebral cooling. FIG. 10 depicts the amount of nasal cooling per different liquid flow rates. The gradient between the cerebral and systemic cooling that forms over time is desirable in order to minimize damage to other organs and hypothermia during the cerebral cooling. In order to create a gradient between the cerebral and systemic temperature, the cerebral cooling must be induced rapidly, for example at a rate of at least about 1° C. in hour, alternatively at least about 1.5° C. in hour, alternatively at least about 2° C. in hour, alternatively at least about 3° C. in hour, alternatively at least about 4° C. in hour, alternatively at least about 5° C. in hour between the cerebral temperature and the systemic temperature. This sudden initial exposure to cold induces a vasoconstriction response in the carotid arteries causing the carotid arteries to constrict, which helps isolate the cerebral vasculature and prevent warmer blood from the heart traveling to the brain and the cooler blood in the brain from traveling to and thereby cooling the rest of the body. This initial vasoconstriction response thus further aids the cooling process by preventing warmer blood from traveling to the head. In addition, the initial cooling

lowers the metabolic demand of the head, thus the carotid artery can further constrict and further isolate the head. After the initial induction, in order to maintain sufficient cooling, the spray may be delivered at a lower flow rate. The lower flow rate may result in a gradient between the cerebral and systemic temperature of at least about 0.1° C., alternatively at least about 0.2° C., alternatively at least about 0.3° C., alternatively at least about 0.4° C., alternatively at least about 0.5° C., alternatively at least about 0.6° C., alternatively at least about 1.0° C., alternatively at least about 1.5° C., alternatively at least about 2.0° C., alternatively at least about 2.5° C., alternatively at least about 3.0° C., alternatively at least about 3.5° C., alternatively at least about 4.0° C., alternatively at least about 4.5° C., alternatively at least about 5.0° C.

[0135] In addition to the liquid flow rate, it has also been shown that the ratio of gas flow rate to liquid flow rate is a critical factor affecting the cerebral cooling within the nasal cavity. Initially, it was thought that increasing the liquid flow rate would increase cooling. The cooling rate, however, only increases if the gas flow is concurrently increased to evaporate the nebulized liquid. This is necessary because the cooling within the nasal cavity is achieved through evaporative heat loss as nebulized liquid evaporates. If the nasal cavity becomes saturated with the evaporated liquid, however, then the evaporation rate decreases and consequently, the cooling rate decreases. Thus, the rate of evaporation is dependant on the concentration of the liquid within the nasal cavity as well as the flow rate of the liquid. Therefore, increasing the liquid flow rate to the nasal cavity only increases the cooling rate if the gas flow rate is also increased to evaporate off the nebulized liquid. The ratio for the liquid delivery rate:gas delivery rate to optimize the evaporation and maintain a constant rate of evaporation preferably ranges from 1:25 mL-1:5000 mL, more preferably from 1:500 mL-1:2000 mL, more preferably from 1:700 mL-1:1500 mL. FIGS. 9-10 depict the varying cooling in an artificial nasal cavity at three different gas flow rates (40 L/min, 30 L/min, and 50 L/min) as the liquid flow rate is varied. The goal is to have 100% evaporation (i.e., "spray"). It is desirable to have the maximum amount of cooling with the least amount of liquid used. Therefore, the gas flow rate should be at least about 30 L/min, alternatively at least about 40 L/min, alternatively at least about 50 L/min. The liquid flow rate should be at least about 40 mL/min, alternatively at least about 50 mL/min, alternatively at least about 60 mL/min, alternatively at least about 70 mL/min, alternatively at least about 80 mL/min, alternatively at least about 90 mL/min, alternatively at least about 100 mL/min.

[0136] The flow rate of the gas and liquid can be altered during the process according changes in a physiological parameter such as the amount of cooling achieved or changes in cerebral blood flow. Feedback can be provided in the form of nose temperature, body temperature, tympanic temperature, brain temperature, rectal temperature, etc. For example, an alarm could be triggered when the body temperature falls below 35° C. and delivery of the fluids and gas could be stopped. Additionally, feedback in the form of the brain temperature or tympanic temperature could be provided such that the rate of delivery of the fluids and gases increases if the cooling rate of the brain is less than about 5° C. in one hour, alternatively less than about 4° C. in one hour, alternatively less than about 3° C. in one hour, alternatively less than about 2° C. in one hour, alternatively less than about 1° C. in one hour. The brain temperature can be measured externally, internally, ultrasonically, by infrared or other waveform. In

the alternative, feedback in the form of changes in cerebral blood flow (CBF) or a surrogate for CBF such as brain oxygenation, MR perfusion, transcranial doppler (TCD) flow rates, could be provided such that the rate of delivery of the fluids and gases can be adjusted in response to the changes in cerebral blood flow.

Cooling Calculations

[0137] The following calculations estimate the maximum cooling that can be obtained using a unit dose of 2 liters of perfluorohexane. The cooling effect of PFH is related to two aspects of thermodynamics: (1) heat capacity of the liquid, as it is warmed from its temperature at application to that of the body and (2) heat of vaporization as it changes from the liquid to the gas state. The relevant properties of perfluorohexane are as follows:

[0138] p, Density: 1.68 grams/ml

[0139] c, Specific Heat: 1.09 kJ/kg ° C.=0.26 cal/g° C.

[0140] h, Latent Heat: 85.5 kJ/kg=20.4 cal/g

[0141] The calculation for heat transfer due to warming the liquid is:

$$Q=c*m*(T2-T1) \text{ or } Q=cm\Delta T \quad \text{Equation 1}$$

[0142] Where m=the mass of the liquid administered

[0143] T1 is the temperature of the liquid at administration

[0144] T2 is the temperature to which the liquid is warmed

[0145] In the patient case, the heat removed is calculated using the following assumptions: (1) a unit dose quantity of 2 liters is used; (2) the PFC is administered at 0° C.; and (3) the PFC is warmed completely to body temperature of 37° C.

$$Q=2000 \text{ ml} * 1.68 \text{ g/ml} * 0.26 \text{ cal/g}^\circ \text{ C.} * (37^\circ \text{ C.} - 0^\circ \text{ C.}) = 32,300 \text{ calories}$$

[0146] The calculation for heat transfer due to evaporation of the liquid is:

$$Q=h*m \quad \text{Equation 2}$$

Therefore, assuming a dose of 2 liters,

$$Q=2000 \text{ ml} * 1.68 \text{ g/ml} * 20.5 \text{ cal/g} = 68,900 \text{ calories}$$

[0147] For a 2 liter quantity of liquid, the maximum heat removal=100,000 calories or 100 Kcal. The amount of cooling to the body can be calculated using the following assumptions: (1) patient weight of 70 Kg, (2) specific heat of patient=0.83 cal/g° C., (3) heat generated by metabolism or other sources is negligible, and (4) other heat added or removed from the patient is negligible. After rearranging Equation 1 ($\Delta T=Q/(c*m)$), the net change in temperature of the whole body of the patient can be calculated as follows:

$$\Delta T=100 \text{ kcal}/(0.83 \text{ cal/g}^\circ \text{ C.} * 70 \text{ kg}) = 1.72^\circ \text{ C.}$$

Therefore, the maximum whole body cooling that could occur from a 2 liter dose is approximately 1.7° C. This should result in a body temperature no lower than 35° C., which should not cause any cold related complications.

[0148] The sensitivity, i.e., the resultant temperature change experienced by the patient, will depend on the size of the patient. For a very small patient of 40 Kg (88 pounds), the resultant temperature change is $\Delta T=100 \text{ kcal}/(0.83 \text{ cal/g}^\circ \text{ C.} * 40 \text{ kg})=2.1^\circ \text{ C.}$ For a very large patient of 100 Kg, the resultant temperature change is $\Delta T=100 \text{ kcal}/(0.83 \text{ cal/g}^\circ \text{ C.} * 100 \text{ kg})=0.83^\circ \text{ C.}$

[0149] By applying the cooling spray to the nasal cavity, there will be more cooling in the head than the remainder of the body. Calculations can be done to determine how cold the head might become if all the cooling is focused solely in the head. The amount of cooling to the head can be calculated using the following assumptions: (1) mass of head=5 kg, (2) specific heat of head=0.83 (same as rest of body), and (3) heat transfer from body (warming from cerebral blood flow) is negligible.

$$\Delta T = q / (s * m) = 100 \text{ kcal} / (0.83 \text{ cal/g}^\circ \text{C} * 5 \text{ kg}) = 24 \text{ Degrees C.}$$

This corresponds to a potential minimum head temperature of 13° C.

[0150] The above calculations assume that every bit of the liquid is warmed fully to body temperature and evaporates completely. It is likely that in a clinical setting, there will be incomplete warming and evaporation. Specifically, some of the gas and vapor leaving the body will not be at 37° C., and some of the liquid will trickle out of the patient without contributing to heat transfer. These effects will tend to reduce the cooling from the calculated values.

[0151] The head cooling calculation assumes that absolutely no heat will be added to the head from the body. This is, however, a poor assumption. The cerebral blood flow is on the order of 1 L per minute, and assuming that this blood is cooled by only 2 degrees while in the head, the calculation becomes as follows:

$$\text{Net heat removal} = 100 \text{ Kcal} - 1000 \text{ ml/min} * 30 \text{ min} * 0.83 \text{ cal/g}^\circ \text{C} * 2^\circ \text{C} = 50 \text{ Kcal}$$

Therefore, the cooling in the head is reduced by at least half of the previously calculated value to 12° C., for a minimum possible 25° C. head temperature

Experimental Data

[0152] In use, the nasal catheter of the present invention was inserted through the nose into the nasal cavity. Temperature was measured at baseline (3 times over 10 minutes) and at every minute or continuously at the ventricle or epidural space, where available, and bladder or rectum during the procedure. A suction catheter was positioned in the patient's mouth to prevent pharyngeal liquid from entering the esophagus and a nasogastric (NG) tube was placed in the patient's stomach to suction any liquid PFC or PFC vapor. NG suction was continuous. Nasal cooling was administered via a nasal catheter with one oxygen/PFC mixer and fan spray nozzle per naris. Nasal prongs were positioned in the narices and secured to the nose by tape. After measurement of baseline temperatures, cooling was initiated. Temperature was monitored until it returned to the baseline value. A portion of the PFC was recovered from the oral suction catheter placed in the back of the patient's throat. This recovered PFC can be reused and recycled. The following parameters were used for the human studies.

[0153] Oxygen was delivered at about 20 L/min throughout the delivery period, alternatively at about 30 L/min throughout the delivery period, alternatively at about 40 L/min throughout the delivery period, depending on the patient.

[0154] The PFC (e.g., perfluorohexane) was delivered at a rate of about 15 mL/min, alternatively at about 25 mL/min, alternatively at about 35 mL/min, alternatively at about 45 mL/min, alternatively at about 50 mL/min, alternatively at about 55 mL/min, alternatively at about 65 mL/min, alternatively at about 75 mL/min, alternatively at about 80 mL/min,

alternatively at about 85 mL/min, alternatively at about 95 mL/min, alternatively at about 100 mL/min, depending on the patient. The liquid flow rate was sometimes started at a lower flow rate (e.g., about 15 mL/min or about 25 mL/min) and increased to a faster flow rate (e.g., about 45 mL/min, about 50 mL/min, or about 100 mL/min). Alternatively, the liquid flow rate was started at a faster flow rate (e.g., about 50 mL/min) and gradually reduced to a slower flow rate (e.g., about 25 mL/min). A total of amount of about 1.0 L of PFC was delivered, alternatively about 1.5 L, alternatively about 2.0 L, depending on the patient.

[0155] The delivery period was approximately 20 minutes, alternatively approximately 25 minutes, alternatively approximately 30 minutes, alternatively approximately 35 minutes, alternatively approximately 40 minutes, alternatively approximately 45 minutes.

[0156] In one method, oxygen is delivered at about 40 L/min and PFC is delivered at about 80 mL/min throughout the delivery period. A total of about 2 L of PFC is delivered. The delivery period is approximately 20 to 25 minutes.

[0157] FIGS. 11-17 illustrate the gradient between the cerebral and systemic temperatures achieved using the methods described above. The rectangles at the bottom of the graphs indicate the delivery periods for that particular therapy. FIG. 18 illustrates the mean cerebral and systemic cooling achieved from the experiments illustrated in FIGS. 11-17. FIG. 19 illustrates the cooling temperatures achieved using various delivery rates. As apparent from the figures, selective cooling of the brain is achieved and maintained over time, even after delivery of the cooling agents has stopped. Typically, a gradient between cerebral and systemic temperature of at least about 0.5° C. can be achieved, alternatively about 1.0° C. can be achieved, alternatively about 1.5° C. can be achieved, alternatively about 2.0° C. can be achieved, alternatively about 2.5° C. can be achieved.

[0158] The catheter of the present invention can also be used in combination with other cooling or heating devices. For example, the catheter may be used in combination with a helmet or cooling cap for synergistic cooling as seen in, for example, U.S. Pat. No. 6,962,600, which is hereby expressly incorporated by reference in its entirety. As seen in FIG. 20, a cooling system 100 comprising a cooling helmet or cap 102 with the nasal catheters or prongs 110 of the present invention attached directly to the cooling helmet or cap. Alternatively, the nasal catheters or prongs may not be attached to the cooling cap or helmet, and still be used in conjunction with the cooling cap or helmet for synergistic cooling (not shown). The cooling system 100 includes a re-circulating liquid refrigerant container 104 with an input line 106 and an output line 108 running from the container 104 to the cooling helmet or cap 102. Alternatively, the helmet may only have an input line where cooling is accomplished through evaporation of the liquid refrigerant within the walls of the cooling helmet or cap (not shown). Additionally, the nasal catheters may be used in combination with a warming blanket to enhance the gradient between the cerebral temperature and the systemic temperature where systemic cooling is inadequate to bring down the brain temperature. In one embodiment, a heat pump could be used in conjunction with a cooling helmet or cap and a warming blanket. The heat pump could take heat from the liquid being circulated to the cooling helmet or cap and pump the heat into the warming blanket. The heat pump could use a refrigerant or thermoelectric cycle.

[0159] In another alternative embodiment, a mask can be used in conjunction with the catheter (single or multi-lumen) to increase the amount of air/oxygen/gas delivered to the nasal cavity. This would result in an increase in the rate of liquid evaporation, and therefore the rate of cooling, without increasing the intranasal pressure. As see in FIG. 21, mask 280, such as a continuous positive airway pressure (CPAP) nasal mask, can have catheter 282 fitted therethrough. The positive pressure is given through mask 280. The pressures given through the mask may be about 0 to about 200 cm H₂O, alternatively about 0 to about 150 cm H₂O, alternatively about 0 to about 100 cm H₂O, alternatively about 0 to about 75 cm H₂O, alternatively about 0 to about 60 cm H₂O, alternatively about 0 to about 50 cm H₂O, alternatively about 0 to about 40 cm H₂O. Valve 284, preferably a one-way valve, at the side of mask 280 can open at a given pressure, thereby releasing excess gas into the atmosphere. Valve 284 acts as a safeguard against high intranasal pressures that could conceivably lead to gas entrapment in the tissue or entry into the venous vasculature, resulting in a pulmonary embolism. Valve 284 may open when the pressure inside the mask reaches about 55 cm H₂O, alternatively about 60 cm H₂O, alternatively about 65 cm H₂O. In use, mask 280 is placed over the nose and nasal catheter 282 is inserted into the nasal cavity, as described previously. Air and gas are expired through the mouth, as in standard CPAP treatment.

[0160] The catheters of the present invention can also be used as drug delivery catheters for delivery of nebulized drugs to the nasal cavity. It is further contemplated that these drugs may be delivered unaccompanied or may be delivered in addition to a cooling agent to facilitate cerebral cooling. As discussed previously, the ability to nebulize the liquid at each delivery port ensures that the distribution of varying sizes of liquid particles will be uniform throughout the nasal cavity, which provides for better evaporation of the liquid spray. The drug delivery catheter may include, but is not limited to, at least 20 delivery ports, alternatively at least 30 delivery ports, alternatively at least 40 delivery ports, alternatively at least 50 delivery ports, alternatively at least 60 delivery ports. Use of such a drug delivery catheter with nebulizing delivery ports may provide more accurate dosing than existing nasal delivery systems, which suffer from problems of liquid dripping down the patient's throat.

[0161] The drug could be provided in a liquid suspension or a mixture. The liquid suspension could utilize various liquid carriers, depending on the drug. Liquid carriers include, but are not limited to, water, saline, PFC, and combinations thereof. Use of saline as a carrier has an advantage in that many drugs are already sold with saline as the carrier. Additionally, there are no suspension problems. Use of a PFC as a carrier has an advantage in that, because the PFC would evaporate, the drug would not be diluted.

[0162] Drugs that may be delivered using an intranasal delivery catheter include, but are not limited to, neuroprotective agents and malignant hyperthermia, insulin, β -blockers, β -agonists, antihistamines, contraceptives, anesthetics, painkillers, antibiotics, steroids, aspirin, sumatriptan, Viagra, nitroglycerin, hormones, neurodrugs, anti-convulsants, prozac, anti-epileptics, analgesics, NMDA antagonists, naran, noxone, naltrexone, anxiolytics, and muscle relaxants.

Other Nasal Catheter Designs

[0163] In an alternative embodiment, as seen in FIGS. 32A-B and 33-36, specialized nasal catheter 800 is described

for the application of a nebulized liquid, preferably a perfluorocarbon (PFC), for cerebral and systemic cooling. This embodiment comprises a multi-lumen elongate member 802 with a length operable to extend a patient's esophagus to be inserted through the nose, and into the esophagus 804. Here, balloon 806 is located near the distal end. This may be used to occlude the esophagus 804. Catheter 800 includes at least a first, second, and third lumen. First lumen 810 of the elongate member may then be used for suctioning vapor and or liquid from the stomach. Second lumen 812 may be exposed proximal to balloon through port 814, to allow suctioning vapor or liquid which enters the upper esophagus. Third lumen 816, which is in fluid communication with multiple ports along catheter 800, may be used as a spray lumen. Fourth lumen is a balloon inflation lumen and is in fluid communication with a chamber defined by balloon 806. In operation, catheter 800 is placed and balloon 806 inflated to occlude the respective passage, i.e., the esophagus. Gastric suction through lumen 810 can be applied per clinical practice. Air (or oxygen) is introduced to the patient through the spray lumen 816 and multiple ports 820 positioned in the nasal cavity. A PFC liquid is added to spray lumen 816; this will produce a fog of droplets in the nasal cavity. Much of the PFC liquid will impact and coalesce on the walls of the nasal cavity and associated passages. This will then drain down to the throat, the majority of which will enter the esophagus where it can be suctioned through the proximal suction port and reused. Some of the PFC may enter the lungs either directly as liquid or as droplets carried on the inhaled breath.

[0164] In addition, as seen in FIGS. 33-36, plug or balloon 822 may be located at the entrance to the nasal cavity to prevent any retrograde flow out of the nose. In an alternate embodiment, the elongate member may be bifurcated outside the nose, with an additional prong and balloon (not shown) for the other nostril. Furthermore, as seen in FIG. 36, catheter 830 may be bifurcated near the proximal end into two tubular members 832 and 834 for delivery of liquid and/or oxygen to the nasal and oral cavities, respectively. With respect to the oral cavity, a second elongate member could be slidably inserted into tubular member 834 for delivering liquid and/or oxygen to the oral cavity. Alternatively, the elongate tubular member inserted into the oral cavity may be independent of the nasal catheter (not shown).

[0165] The advantages of this invention include: relative ease of placement; available port provides same function as nasogastric tube; similarity to standard nasogastric tubes in design and use; ease of breathing, speaking, etc., through mouth for the patient; liquid flow rate is not dependant on ventilation and can be set by clinician; high turnover flow through cooling enabled; utilization of well perfused anatomical features; perfluorocarbon is well tolerated in lungs; perfluorocarbon in the stomach is also tolerated, and can be easily suctioned with the gastric portion of the catheter.

[0166] The compositions of the invention include liquids having a boiling point of about 38-300° C., more preferably a boiling point of about 38-200° C., more preferably a boiling point of about 60-150° C., more preferably a boiling point of about 70-125° C., more preferably a boiling point of about 75-110° C., more preferably a boiling point of about 60-70° C. Compounds having suitable characteristics for use herein include hydrocarbons, fluorocarbons, perfluorocarbons, and perfluorohydrocarbons. Saline is another example of a substance having suitable characteristics for use herein. As used in this specification, the terms "fluorocarbon," "perfluorocar-

bon,” and “perfluorohydrocarbon” are synonymous. In addition to containing carbon and fluorine, these compounds may also contain other atoms. In one embodiment, the compounds could contain a heteroatom, such as nitrogen, oxygen, or sulfur, or a halogen, such as bromine or chlorine. These compounds may be linear, branched, or cyclic, saturated or unsaturated, or any combination thereof.

[0167] In another embodiment, the compounds are highly fluorinated compounds, which are compounds containing at least three fluorine atoms. These highly fluorinated compounds may also contain other atoms besides carbon and fluorine. These other atoms include, but are not limited to, hydrogen; heteroatoms such as oxygen, nitrogen, and sulfur; and halogens such as bromine or chlorine. In one embodiment, the number of the atoms that are not carbon or fluorine comprise a minority of the total number of atoms in the compound. These highly fluorinated compounds may be linear, branched, or cyclic, saturated or unsaturated, or any combination thereof. Examples of these compounds include, but are not limited to, C_2F_9Br (b.p. $43^\circ C.$), $CF_3CF(CF_3)CF=CF_2$ (b.p. $51^\circ C.$), and $CF_3CF(CF_3)CH=CH_2$.

[0168] In another embodiment, the compounds are hydrofluorocarbons, which are compounds where the number of hydrogen atoms exceeds the number of fluorine atoms. These hydrofluorocarbons may also contain other atoms besides hydrogen, carbon, and fluorine. These other atoms include, but are not limited to, heteroatoms such as oxygen, nitrogen, and sulfur and halogens such as chlorine and bromine. For example, hydrofluorocarbons include, but are not limited to, hydrochlorofluorocarbons, more specifically, hydrochlorofluoralkanes. In one embodiment, the number of the atoms other than carbon and fluorine comprise a minority of the total number of atoms in the compound. These hydrofluorocarbons may be linear, branched, or cyclic, saturated or unsaturated, or any combination thereof.

[0169] A mixture of two or more highly fluorinated compounds, hydrofluorocarbons, light fluorocarbons, hydrocarbons, fluorocarbons, perfluorocarbons, perfluorohydrocarbons, or any of the above-mentioned compounds may also be used. The mixture may contain any of the previously mentioned compounds in different phases (e.g., one gas, one liquid). The mixture has a boiling point above $37^\circ C.$, even though any individual component of the mixture may have a boiling point below $37^\circ C.$

[0170] Light fluorocarbons are fluorocarbons that have a boiling point below $37^\circ C.$ These light fluorocarbons may also contain other atoms besides carbon, and fluorine. These other atoms include, but are not limited to, hydrogen; heteroatoms such as oxygen, nitrogen, and sulfur; and halogens such as chlorine and bromine. For example, light fluorocarbons include, but are not limited to perfluorobutane and perfluoropentane. In one embodiment, the number of the atoms other than carbon and fluorine comprise a minority of the total number of atoms in the compound. These light fluorocarbons may be linear, branched, or cyclic, saturated or unsaturated, or any combination thereof.

[0171] In certain methods, a liquid having a boiling point of $38-300^\circ C.$, more preferably having a boiling point of $38-200^\circ C.$, more preferably having a boiling point of $38-150^\circ C.$, is selected. The liquid is nebulized to form a mist. The droplets preferably range in size from 0.1-100 microns, more preferably 1-5 microns, more preferably 2-4 microns. The mist is optionally cooled below body temperature and delivered to the airway of a patient so that the patient inhales

the mist. Inhalation of the mist causes systemic cooling by heat transfer from the lungs to the cooler mist and/or by evaporative heat loss as the mist evaporates. The administration of the liquid is continued until the systemic temperature is reduced to $35^\circ C.$ or below, more preferably to $34^\circ C.$ or below, more preferably to $33^\circ C.$ or below. The rate of cooling can be adjusted by varying the temperature of the inhaled, the concentration of the responsible compound or compound mixture, the rate of delivery, the particle size, and the percentage of each compound in the mixture.

[0172] Nitric oxide or adrenergic agents, such as adrenaline (epinephrine) or albuterol, may be added in minute doses to the compositions described in any of the previously described embodiments. The NO or other agent is inhaled and acts as a potent nasal vasodilator, which improves the rate of action of the cooling mist and counteracts nasal vasoconstriction caused by administering cold substances to the nasal cavity. The NO may be included in an amount of about 2 to about 80 parts per million, in other cases in an amount of about 3 to about 20 parts per million, in other cases in an amount of about 4 to about 10 parts per million, in other cases in an amount of about 5 to about 8 parts per million, in other cases in an amount of about 5 parts per million.

[0173] In other methods, administration of cold mists will occur in cycles with intervening cycles of administering another gas, preferably a cold dry gas such as dry air or dry heliox, e.g., a mixture of helium and oxygen. With continuous administration of perfluorocarbon mist, the gaseous phase in the nasal cavity may become saturated with gaseous PFC, thereby slowing the rate of evaporative heat loss. In order to accelerate the rate of evaporative heat loss, it may be desired to periodically purge nasal cavity of perfluorocarbon. This can be done by cycling administration of cold mists with administering another gas, preferably a dry gas such as dry air or dry heliox.

[0174] Where cycling is desired, it is recommended that the cycles occur for about 3 seconds or more, in other cases for about 30 seconds or more, in other cases for about one minute or more, in other cases for about two minutes or more, in other cases for about five minutes or more, in other cases for about ten minutes or more, in other cases for about 30 minutes or more. The intervening cycle of dry gas may last for an equal period (e.g., about 3 seconds of cold mist followed by about 3 seconds of dry gas, about 30 seconds of cold mist followed by about 30 seconds of dry gas, about one minute of cold mist followed by about one minute of dry gas, about two minutes of cold mist followed by about two minutes of dry gas, about five minutes of cold mist followed by about five minutes of dry gas, about ten minutes of cold mist followed by about ten minutes of dry gas, about 30 minutes of cold mist followed by about 30 minutes of dry gas, or for a shorter or longer period (about ten minutes of cold mist followed by about two minutes of dry gas).

[0175] In certain methods, a liquid having a boiling point of $38-300^\circ C.$ is selected. The liquid is nebulized to form a mist. The droplets preferably range in size from 1-5 microns. The mist is delivered to the nasal and/or oral cavities of a patient so that the patient inhales the mist. Inhalation of the mist causes cerebral cooling by heat transfer to the cooler mist and/or by evaporative heat loss. In addition indirect hematogenous cooling occurs through the carotids as they pass by the oropharynx and through the Circle of Willis which lies millimeters away from the pharynx. The administration of the liquid is continued until the cerebral temperature is reduced to $35^\circ C.$ or below, more preferably to

34° C. or below, more preferably to 33° C. or below. In certain methods, the administration of the liquid may be continued to provide for systemic cooling as well as cerebral cooling. In certain methods, the liquid may be cooled to below body temperature before delivery. The mist droplets may range in size from 1-5 microns.

[0176] The table in FIG. 37 lists the parameters and results for cerebral cooling trials where the perfluorocarbon mixture used and the flow rate at which it was provided were varied. The column entitled “PFC” lists the perfluorocarbon used and the column entitled “PFC flow mL/min” lists the flow rate at which the PFC was administered. As seen from the “Cooling Rate” data, the faster the rate of administration of PFC, the greater the cooling. The gas flow rate is listed in the column entitled “O₂ Flow L/min;” the greater the gas flow rate, the greater the cooling. In this experiment, the gas joined the liquid in a box and generated a spray. The spray was then delivered to the nasal cavity. Possible nasal trauma limited the speed of delivery; for example, nasal bleeding may be rate

limiting. The ratio between the gas and the liquid was varied (e.g., 1:1, 1:2, 1:3) with varying effect on cooling rates. The column entitled “BIAS flow” is CPAP (continuous positive airway pressure) air under several atmospheres of pressure to enhance spray entry during inspiration. Cooling was measured in Head-F (frontal lobe of the brain), Head V (ventricle of the brain), Head-S (superficial, cortical, and posterior portions of the brain), Vasc (vascular column), and Rectal (rectal column). Systemic column was measured in the vascular column. From the measurements it appears that Head F cools first and the fastest. Subsequently, the cold diffuses back to the ventricle and then to surface. A gradient is created within the brain and between brain and blood, such that brain cooling is more marked early on (20-30 degrees in one hour) than blood (10 degrees in one hour), systemic cooling, or rectal cooling. This gradient eventually disappears.

[0177] FIG. 38 shows a plot of brain temperatures against time for different runs listed in FIG. 37. Table 1 (below) shows additional experimental data wherein the cooling liquid and the flow rate were varied.

TABLE 1

TIME	1:HEAD-F	1:HEAD-V	HEAD-S	1:ESOPH	1:IM	1:SUBQ	1:RECTAL	1:VASC
12:26:52	37.7	38.1	38.5	36.8	38.5	36.7	38.4	37.7
12:26:56	37.7	38.1	38.5	36.7	38.5	36.7	38.4	37.7
12:27:01	37.7	38.1	38.5	36.5	38.4	36.7	38.4	37.6
12:27:05	37.7	38.1	38.5	35.8	38.4	36.7	38.4	37.6
12:27:09	37.7	38.1	38.5	35.2	38.4	36.7	38.3	37.6
12:27:13	37.6	38.1	38.5	35	38.4	36.7	38.4	37.5
12:27:17	37.6	38	38.4	34.6	38.4	36.7	38.3	37.3
12:27:21	37.6	37.9	38.4	34.2	38.4	36.7	38.3	37.3
12:27:26	37.5	37.8	38.4	34	38.4	36.7	38.4	37.1
12:27:30	37.4	37.8	38.5	33.3	38.5	36.7	38.4	37.1
12:27:34	37.3	37.7	38.5	33.1	38.4	36.7	38.3	37
12:27:38	37.3	37.7	38.4	32.9	38.4	36.7	38.3	36.9
12:27:42	37.2	37.6	38.4	32.8	38.3	36.7	38.3	36.8
12:27:46	37.1	37.6	38.4	32.5	38.3	36.7	38.3	36.7
12:27:50	37.1	37.5	38.3	32.5	38.4	36.7	38.4	36.7
12:27:55	37	37.5	38.3	32.3	38.4	36.7	38.3	36.7
12:27:59	36.9	37.4	38.3	32.2	38.4	36.7	38.3	36.7
12:28:03	36.9	37.4	38.3	32.2	38.4	36.7	38.3	36.6
12:28:07	36.8	37.4	38.3	32.2	38.5	36.7	38.3	36.6
12:28:11	36.7	37.3	38.3	32.1	38.4	36.7	38.4	36.5
12:28:15	36.7	37.3	38.3	31.8	38.4	36.7	38.3	36.6
12:28:20	36.7	37.3	38.3	31.7	38.4	36.7	38.4	36.7
12:28:24	36.6	37.2	38.3	31.6	38.4	36.8	38.4	36.8
12:28:28	36.4	37.2	38.2	31.5	38.4	36.7	38.4	36.9
12:28:32	36.5	37.2	38.3	31.3	38.5	36.7	38.3	36.8
12:28:36	36.5	37.1	38.2	31.2	38.4	36.7	38.4	36.8
12:28:40	36.5	37.1	38.2	31.1	38.4	36.7	38.3	36.8
12:28:44	36.4	37.1	38.2	31.1	38.4	36.8	38.4	36.7
12:28:49	36.3	37.1	38.2	31	38.4	36.7	38.3	36.8
12:28:53	36.3	37	38.1	30.9	38.4	36.7	38.3	37
12:28:57	36.2	37	38.1	30.9	38.4	36.7	38.4	36.8
12:29:01	36.2	37	38.1	30.8	38.4	36.7	38.3	36.8
12:29:05	36.2	37	38.1	30.7	38.4	36.7	38.3	36.8
12:29:09	36.1	36.9	38.1	29.9	38.4	36.7	38.3	36.8
12:29:13	36.1	36.9	38.1	29.8	38.4	36.7	38.3	36.6
12:29:18	36.1	37	38.1	30	38.4	36.7	38.3	36.5
12:29:22	36	37	38.1	30.1	38.4	36.7	38.3	36.7
12:29:26	36.1	37	38.1	30.5	38.4	36.7	38.3	36.5
12:29:30	36	37	38	30.5	38.4	36.7	38.3	36.6
12:29:34	36	37	38	30.5	38.5	36.7	38.3	36.5
12:29:38	36	36.9	38	30.6	38.4	36.7	38.3	36.5
12:29:43	36	36.9	38	30.6	38.4	36.7	38.3	36.4
12:29:47	35.9	36.8	38	30.2	38.4	36.7	38.3	36.5
12:29:51	35.9	36.8	38	30.3	38.4	36.7	38.3	36.7
12:29:55	35.9	36.8	38	30.2	38.4	36.7	38.3	36.7
12:29:59	35.8	36.8	37.9	30.3	38.4	36.7	38.3	36.7
12:30:03	35.8	36.8	38	30.3	38.4	36.7	38.3	36.7
12:30:07	35.8	36.7	37.9	30.5	38.4	36.7	38.3	36.7

TABLE 1-continued

12:30:12	35.7	36.7	37.8	30.5	38.4	36.7	38.3	36.7
12:30:16	35.7	36.7	37.9	30.6	38.5	36.7	38.3	36.7
12:30:20	35.7	36.7	37.8	30.6	38.4	36.7	38.3	36.7
12:30:24	35.7	36.6	37.8	30.6	38.4	36.7	38.3	36.7
12:30:28	35.6	36.6	37.8	30.5	38.4	36.7	38.3	36.7
12:30:32	35.6	36.6	37.8	30.2	38.4	36.7	38.3	36.6
2:30:36	35.6	36.6	37.8	30.5	38.4	36.7	38.3	36.7
12:30:41	35.6	36.6	37.7	30.5	38.4	36.7	38.3	36.7
12:30:45	35.5	36.5	37.7	30.3	38.4	36.7	38.2	36.7
12:30:49	35.5	36.5	37.7	30.2	38.4	36.7	38.3	36.7
12:30:53	35.5	36.5	37.7	30.2	38.4	36.7	38.3	36.6
12:30:57	35.5	36.5	37.7	30.1	38.4	36.7	38.2	36.6
12:31:01	35.3	36.4	37.6	30.2	38.3	36.6	38.2	36.7
12:31:06	35.3	36.4	37.6	30.1	38.4	36.7	38.2	36.7
12:31:10	35.3	36.5	37.6	30.1	38.4	36.7	38.2	36.7
12:31:14	35.3	36.5	37.6	30	38.4	36.6	38.2	36.6
12:31:18	35.3	36.5	37.6	30.1	38.4	36.7	38.3	36.6
12:31:22	35.2	36.4	37.6	30.2	38.4	36.7	38.2	36.7
12:31:26	35.2	36.4	37.6	30.2	38.4	36.7	38.2	36.7
12:31:30	35.2	36.3	37.6	30.2	38.4	36.7	38.2	36.7
12:31:35	35.1	36.3	37.5	30.1	38.4	36.6	38.2	36.6
12:31:39	35.1	36.3	37.5	30.1	38.3	36.6	38.2	36.7
12:31:43	35.1	36.3	37.5	30.2	38.4	36.7	38.2	36.7
12:31:47	35.1	36.3	37.5	30.1	38.4	36.6	38.2	36.6
12:31:51	35.1	36.3	37.5	30.1	38.3	36.7	38.2	36.6
12:31:55	35.1	36.3	37.4	30.2	38.4	36.6	38.2	36.6
12:31:59	35.1	36.3	37.5	30.2	38.3	36.6	38.2	36.5
12:32:04	35	36.2	37.4	30.1	38.4	36.6	38.2	36.6
12:32:08	35	36.2	37.4	30.1	38.4	36.6	38.2	36.6
12:32:12	35	36.2	37.4	30.1	38.4	36.6	38.2	36.6
12:32:16	34.9	36.2	37.4	30.1	38.4	36.6	38.2	36.6
12:32:20	34.9	36.2	37.4	30.1	38.4	36.6	38.2	36.6
12:32:24	34.9	36.1	37.3	30.1	38.4	36.6	38.2	36.6
12:32:29	34.8	36.1	37.3	30.1	38.4	36.6	38.2	36.6
12:32:33	34.8	36.1	37.3	30	38.4	36.7	38.2	36.5
12:32:37	34.8	36.1	37.3	30	38.3	36.6	38.1	36.6
12:32:41	34.8	36.1	37.2	29.8	38.3	36.6	38.1	36.6
12:32:45	34.8	36.1	37.2	29.8	38.3	36.6	38.2	36.6
12:32:49	34.8	36	37.2	29.8	38.4	36.6	38.2	36.6
12:32:53	34.7	36	37.2	29.8	38.4	36.6	38.2	36.6
12:32:58	34.7	36	37.2	29.8	38.3	36.6	38.2	36.7
12:33:02	34.7	36	37.1	29.8	38.3	36.6	38.1	36.6
12:33:06	34.7	36	37.1	29.5	38.3	36.6	38.1	36.6
12:33:10	34.7	36	37.1	29.5	38.3	36.6	38.1	36.5
12:33:14	34.7	36	37.1	29.5	38.3	36.6	38.2	36.6
12:33:18	34.6	35.9	37.1	29.5	38.3	36.6	38.1	36.6
12:33:23	34.6	36	37.1	29.5	38.4	36.6	38.1	36.7
12:33:27	34.6	36	37.1	29.5	38.4	36.6	38.1	36.7
12:33:31	34.6	35.9	37.1	29.5	38.3	36.6	38.1	36.7
12:33:35	34.6	35.9	37.1	29.4	38.3	36.6	38.1	36.6
12:33:39	34.6	35.9	37	29.3	38.3	36.6	38.1	36.6
12:33:43	34.6	36	37	29.4	38.4	36.6	38.1	36.6
12:33:47	34.6	36	37	29.3	38.3	36.6	38.1	36.6
12:33:52	34.6	36	37	29.3	38.3	36.6	38.1	36.6
12:33:56	34.6	36	37	29.2	38.3	36.6	38.1	36.6
12:34:00	34.7	36	37	29.2	38.3	36.6	38.1	36.6
12:34:04	34.7	36	37	29.2	38.4	36.7	38.2	36.6
12:34:08	34.6	36	37	29.1	38.3	36.6	38.1	36.5
12:34:12	34.6	36	37	29.2	38.3	36.6	38.1	36.6
12:34:16	34.6	36	37	29.1	38.3	36.6	38.1	36.5
12:34:21	34.6	36	36.9	29.1	38.3	36.6	38.1	36.6
12:34:25	34.6	36	36.9	29	38.3	36.6	38.1	36.5
12:34:29	34.6	35.9	37	29	38.4	36.6	38.1	36.5
12:34:33	34.5	35.9	36.9	29	38.3	36.6	38.1	36.5
12:34:37	34.5	35.9	36.9	28.9	38.3	36.6	38.1	36.4
12:34:41	34.5	35.9	36.9	28.9	38.3	36.6	38.1	36.5
12:34:46	34.5	35.9	36.9	28.9	38.3	36.6	38.1	36.5
12:34:50	34.5	35.8	36.8	28.8	38.3	36.6	38.1	36.5
12:34:54	34.5	35.8	36.8	28.8	38.3	36.6	38.1	36.4
12:34:58	34.5	35.8	36.8	29	38.3	36.6	38.1	36.3
12:35:02	34.4	35.8	36.8	29.1	38.3	36.6	38.1	36.3
12:35:06	34.5	35.8	36.8	29.1	38.3	36.6	38.1	36.3
12:35:11	34.4	35.7	36.8	29	38.3	36.5	38.1	36.3
12:35:15	34.3	35.7	36.8	29	38.3	36.6	38	36.3
12:35:19	34.3	35.7	36.8	29	38.3	36.6	38.1	36.4
12:35:23	34.2	35.6	36.7	28.9	38.3	36.6	38	36.3

TABLE 1-continued

12:35:27	34.2	35.6	36.7	29	38.3	36.5	38	36.3
12:35:31	34.2	35.6	36.7	29.1	38.3	36.5	38	36.3
12:35:35	34.2	35.7	36.7	29.1	38.3	36.5	38	36.3
12:35:40	34.2	35.7	36.7	29.1	38.3	36.5	38.1	36.3
12:35:44	34.2	35.7	36.7	29.2	38.3	36.5	38	36.3
12:35:48	34.2	35.6	36.7	29.2	38.3	36.5	38	36.4
12:35:52	34.2	35.6	36.6	29.2	38.3	36.5	38	36.5
12:35:56	34.1	35.5	36.6	29.2	38.3	36.5	38	36.4
12:36:00	34.1	35.6	36.7	29.1	38.3	36.5	38	36.4
12:36:04	34.1	35.5	36.6	29.2	38.3	36.5	38.1	36.5
12:36:09	34.1	35.5	36.6	29.2	38.3	36.5	38	36.4
12:36:13	34.1	35.5	36.6	29.2	38.3	36.5	38	36.3
12:36:17	34	35.5	36.6	29.2	38.3	36.5	38	36.4
12:36:21	34	35.5	36.6	29.2	38.3	36.5	38	36.4
12:36:25	34	35.5	36.6	29.3	38.3	36.5	37.9	36.4
12:36:29	34	35.5	36.5	28.9	38.3	36.5	38	36.4
12:36:34	34	35.5	36.5	29	38.3	36.5	38	36.4
12:36:38	34	35.5	36.5	29.1	38.3	36.5	38	36.3
12:36:42	33.9	35.4	36.5	29.1	38.3	36.5	38	36.4
12:36:46	33.9	35.4	36.5	29.2	38.3	36.5	38	36.3
12:36:50	33.9	35.3	36.5	29.2	38.3	36.5	38	36.3
12:36:54	33.8	35.4	36.5	29.2	38.3	36.5	38	36.3
12:36:58	33.8	35.3	36.5	29.2	38.2	36.5	38	36.3
12:37:03	33.8	35.4	36.5	29.2	38.3	36.5	38	36.4
12:37:07	33.8	35.3	36.5	29.2	38.3	36.4	38	36.3
12:37:11	33.8	35.3	36.5	29.2	38.3	36.5	38	36.3
12:37:15	33.8	35.3	36.4	29.2	38.2	36.4	37.9	36.3
12:37:19	33.8	35.3	36.5	29.3	38.3	36.5	38	36.3
12:37:23	33.8	35.3	36.4	29.2	38.3	36.5	38	36.3
12:37:28	33.8	35.3	36.4	29.2	38.2	36.5	37.9	36.3
12:37:32	33.8	35.3	36.4	29.2	38.2	36.4	37.9	36.3
12:37:36	33.7	35.2	36.3	29.2	38.2	36.4	37.9	36.2
12:37:40	33.7	35.2	36.4	29.2	38.2	36.4	38	36.2
12:37:44	33.7	35.2	36.4	29.2	38.2	36.5	38	36.2
12:37:48	33.7	35.2	36.3	29.2	38.2	36.4	37.9	36.2
12:37:53	33.7	35.2	36.3	28.7	38.3	36.4	37.9	36.2
12:37:57	33.7	35.2	36.3	28.7	38.2	36.4	37.9	36.2
12:38:01	33.7	35.2	36.3	28.7	38.3	36.5	37.9	36.1
12:38:05	33.7	35.2	36.3	28.7	38.3	36.5	38	36.1
12:38:09	33.6	35.2	36.3	28.6	38.2	36.4	37.9	36
12:38:13	33.6	35.2	36.3	28.6	38.2	36.4	37.9	36.1
12:38:17	33.6	35.2	36.2	28.6	38.2	36.4	37.8	36
12:38:21	33.6	35.2	36.3	28.6	38.2	36.5	37.9	36.1
12:38:25	33.6	35.2	36.3	28.6	38.3	36.5	37.9	36.1
12:38:30	33.6	35.1	36.2	28.5	38.2	36.4	37.8	36
12:38:34	33.6	35.2	36.2	28.5	38.3	36.4	37.9	36
12:38:38	33.6	35.1	36.2	28.5	38.2	36.4	37.8	36.1
12:38:42	33.6	35.1	36.1	28.4	38.2	36.3	37.8	36.1
12:38:46	33.6	35.1	36.2	28.3	38.2	36.4	37.8	36.1
12:38:50	33.6	35.1	36.2	28.4	38.2	36.5	37.9	36.2
12:38:55	33.6	35.1	36.2	28.3	38.2	36.4	37.9	36
12:38:59	33.6	35.1	36.1	28.4	38.2	36.4	37.8	36.1
12:39:03	33.6	35.1	36.2	28.3	38.2	36.4	37.8	36.1
12:39:07	33.5	35.1	36.1	28.3	38.2	36.3	37.8	36.1
12:39:11	33.6	35.1	36.1	28.3	38.2	36.3	37.8	36.1
12:39:15	33.6	35.1	36.1	28.3	38.2	36.4	37.8	36.1
12:39:19	33.6	35.1	36.1	28.3	38.2	36.4	37.8	36.1
12:39:24	33.5	35.1	36.1	28.2	38.2	36.3	37.8	36
12:39:28	33.6	35.1	36.1	28.2	38.2	36.4	37.8	36.1
12:39:32	33.5	35.1	36.1	28.1	38.2	36.3	37.8	36
12:39:36	33.6	35.1	36.1	28.2	38.2	36.4	37.8	36
12:39:40	33.5	35	36.1	28.1	38.2	36.3	37.8	36
12:39:44	33.6	35	36	28.1	38.2	36.3	37.8	36.1
12:39:49	33.6	35	36	28.1	38.2	36.3	37.8	36.1
12:39:53	33.5	35	36	28.1	38.2	36.3	37.8	36
12:39:57	33.5	35	36	28	38.2	36.3	37.8	36.1
12:40:01	33.5	35	36	28	38.2	36.3	37.8	36
12:40:05	33.5	35	36	27.9	38.2	36.3	37.8	36
12:40:09	33.5	35	36	28	38.2	36.3	37.8	36.1
12:40:13	33.5	35	36	27.9	38.2	36.3	37.8	36.2
12:40:18	33.5	35	36	27.9	38.2	36.3	37.8	36
12:40:22	33.5	35	36	27.9	38.2	36.3	37.8	36
12:40:26	33.5	35	36	27.9	38.2	36.3	37.8	36
12:40:30	33.5	35	36	27.9	38.2	36.3	37.7	36
12:40:34	33.5	35	36	27.9	38.2	36.3	37.7	36
12:40:38	33.5	35	35.9	27.8	38.2	36.3	37.7	36

TABLE 1-continued

12:40:42	33.5	35	36	27.8	38.2	36.3	37.7	36
12:40:47	33.5	35	35.9	27.8	38.1	36.3	37.8	36
12:40:51	33.5	35	36	27.7	38.2	36.3	37.7	35.9
12:40:55	33.6	34.9	35.9	27.8	38.2	36.3	37.8	35.9
12:40:59	33.5	34.9	35.9	27.8	38.2	36.3	37.7	35.9
12:41:03	33.5	34.9	35.9	27.7	38.2	36.3	37.7	36
12:41:07	33.5	34.9	35.9	27.8	38.2	36.3	37.7	35.9
12:41:12	33.6	34.9	35.9	27.7	38.2	36.3	37.7	36
12:41:16	33.5	34.9	35.9	27.7	38.2	36.3	37.7	36
12:41:20	33.5	34.9	35.9	27.6	38.2	36.3	37.7	35.9
12:41:24	33.6	34.9	35.8	27.6	38.1	36.3	37.7	36
12:41:28	33.5	34.9	35.8	27.6	38.1	36.3	37.7	36
12:41:32	33.6	34.9	35.8	27.6	38.1	36.3	37.7	35.8
12:41:36	33.5	34.8	35.8	27.6	38.1	36.2	37.7	35.8
12:41:41	33.6	34.9	35.8	27.6	38.1	36.3	37.7	35.9
12:41:45	33.5	34.8	35.8	27.7	38.1	36.2	37.7	35.9
12:41:49	33.6	34.8	35.8	27.7	38.1	36.3	37.7	35.8
12:41:53	33.6	34.8	35.8	27.8	38.1	36.3	37.7	35.9
12:41:57	33.6	34.9	35.8	28	38.1	36.3	37.7	35.8
12:42:01	33.6	35	35.8	28	38.1	36.3	37.7	35.8
12:42:05	33.7	35	35.7	28.6	38.1	36.3	37.7	35.7
12:42:10	33.7	35	35.8	28.3	38.1	36.3	37.7	35.9
12:42:14	33.7	35	35.7	28.2	38.1	36.2	37.7	35.8
12:42:18	33.8	35.1	35.8	28	38.1	36.2	37.7	35.8
12:42:22	33.8	35.1	35.8	27.8	38.1	36.3	37.7	35.8
12:42:26	33.9	35.1	35.7	27.7	38.1	36.3	37.7	35.8
12:42:30	33.9	35.1	35.7	27.6	38.1	36.2	37.7	35.8
12:42:35	34	35.1	35.8	27.6	38.1	36.3	37.7	35.9
12:42:39	34	35.1	35.7	27.5	38.1	36.3	37.7	35.9
12:42:43	34	35.1	35.8	27.5	38.1	36.3	37.7	35.8
12:42:47	34	35.1	35.7	27.4	38.1	36.3	37.7	35.7
12:42:51	34	35.1	35.7	27.3	38.1	36.2	37.7	35.8
12:42:55	34	35.1	35.7	27.2	38.1	36.3	37.7	35.8
12:42:59	34.1	35.1	35.8	27.2	38.1	36.3	37.7	35.8
12:43:04	34.1	35.1	35.8	27.2	38.1	36.3	37.7	35.9
12:43:08	34	35.1	35.7	27.2	38.1	36.2	37.6	35.8
12:43:12	34.1	35.1	35.7	27.3	38	36.2	37.6	35.7
12:43:16	34.1	35.1	35.7	27.5	38.1	36.2	37.6	35.6
12:43:20	34.2	35.2	35.7	27.5	38.1	36.2	37.6	35.7
12:43:24	34.3	35.3	35.7	27.6	38.1	36.2	37.6	35.7
12:43:28	34.3	35.5	35.7	27.6	38.1	36.2	37.6	35.8
12:43:33	34.4	35.5	35.7	27.5	38.1	36.2	37.6	35.8
12:43:37	34.5	35.5	35.7	27.5	38.1	36.2	37.6	35.8
12:43:41	34.7	35.5	35.7	27.4	38.1	36.2	37.6	35.7
12:43:45	34.7	35.5	35.8	27.4	38.1	36.2	37.6	35.7
12:43:49	34.7	35.5	35.8	27.4	38.1	36.2	37.6	35.8
12:43:53	34.7	35.5	35.8	27.3	38	36.2	37.6	35.7
12:43:58	34.7	35.4	35.7	27.4	38.1	36.2	37.6	35.6
12:44:02	34.8	35.5	35.8	27.4	38.1	36.2	37.6	35.8
12:44:06	34.8	35.6	35.8	27.5	38.1	36.2	37.6	35.7
12:44:10	34.8	35.6	35.8	27.5	38	36.2	37.6	35.6
12:44:14	34.9	35.6	35.8	27.5	38	36.2	37.6	35.5
12:44:18	35	35.6	35.8	27.5	38	36.2	37.6	35.6
12:44:22	35	35.6	35.8	27.6	38	36.2	37.6	35.8
12:44:27	35.1	35.7	35.8	27.7	38.1	36.2	37.6	35.8
12:44:31	35.1	35.6	35.8	27.7	38	36.2	37.6	35.8
12:44:35	35.1	35.7	35.8	27.7	38	36.2	37.6	35.8
12:44:39	35.1	35.6	35.8	27.7	38	36.2	37.5	35.7
12:44:43	35.1	35.6	35.9	27.8	38.1	36.2	37.5	35.6
12:44:47	35.1	35.6	35.9	27.8	38	36.2	37.6	35.7
12:44:52	35.1	35.6	35.8	27.7	38	36.2	37.6	35.8
12:44:56	35.1	35.7	35.8	27.6	38	36.1	37.5	35.7
12:45:00	35.1	35.7	35.8	27.6	38	36.2	37.6	35.5
12:45:04	35.2	35.7	35.9	27.5	38	36.2	37.6	35.6
12:45:08	35.2	35.7	35.9	27.6	38	36.2	37.6	35.7
12:45:12	35.2	35.8	35.8	27.5	38	36.2	37.6	35.7
12:45:17	35.2	35.8	35.8	27.5	38	36.2	37.5	35.7
12:45:21	35.2	35.8	35.9	27.5	38	36.1	37.6	35.7
12:45:25	35.3	35.8	35.9	27.5	38	36.1	37.6	35.6
12:45:29	35.3	35.8	35.9	27.5	38	36.1	37.5	35.5
12:45:33	35.3	35.8	35.9	27.5	38	36.2	37.6	35.6
12:45:37	35.3	35.8	36	27.5	38	36.2	37.6	35.8
12:45:41	35.3	35.7	35.9	27.5	38	36.1	37.5	35.7
12:45:46	35.2	35.7	35.9	27.6	38	36.1	37.5	35.6
12:45:50	35.2	35.7	36	27.6	38	36.1	37.6	35.6
12:45:54	35.2	35.7	35.9	27.6	38	36.1	37.5	35.7

TABLE 1-continued

12:45:58	35.2	35.7	36	27.6	38	36.1	37.5	35.7
12:46:02	35.3	35.8	35.9	27.6	38	36.1	37.5	35.7
12:46:06	35.3	35.8	36	27.6	38	36.1	37.5	35.6
12:46:10	35.3	35.8	36	27.6	38	36.2	37.5	35.6
12:46:15	35.3	35.8	35.9	27.6	38	36.1	37.5	35.6
12:46:19	35.3	35.9	36	27.8	38	36.1	37.5	35.7
12:46:23	35.3	35.9	36	27.7	38	36.1	37.5	35.6
12:46:27	35.4	35.9	36	27.7	38	36.2	37.6	35.7
12:46:31	35.4	35.9	36	27.6	38	36.1	37.5	35.7
12:46:35	35.5	35.9	36	27.5	38	36.1	37.5	35.6
12:46:40	35.5	35.9	36	27.5	38	36.1	37.5	35.5
12:46:44	35.5	35.9	36	27.5	38	36.1	37.5	35.6
12:46:48	35.5	35.9	36	27.5	38	36.1	37.5	35.6
12:46:52	35.5	36	36	27.5	38	36.1	37.5	35.6
12:46:56	35.5	35.9	36	27.5	38	36.1	37.5	35.6
12:47:00	35.5	36	36	27.4	38	36.1	37.4	35.7
12:47:04	35.5	35.9	36	27.3	38	36.1	37.5	35.7
12:47:08	35.5	35.9	36	27.3	38	36.1	37.5	35.7
12:47:13	35.5	35.9	36	27.2	38	36.1	37.5	35.6
12:47:17	35.5	35.9	36.1	27.1	38	36.1	37.5	35.7
12:47:21	35.5	35.9	36.1	27.1	38	36.1	37.4	35.6
12:47:25	35.5	35.9	36	27.1	38	36.1	37.5	35.5
12:47:29	35.5	36	36.1	27.1	38	36.1	37.4	35.6
12:47:33	35.5	35.9	36	27.1	38	36.1	37.4	35.7
12:47:37	35.5	36	36.1	27	38	36	37.4	35.7
12:47:42	35.5	36	36	27	38	36.1	37.4	35.7
12:47:46	35.5	36	36.1	27	38	36	37.4	35.7
12:47:50	35.5	35.9	36	27	38	36.1	37.5	35.7
12:47:54	35.5	36	36	26.8	38	36	37.4	35.7
12:47:58	35.6	36	36.1	26.9	38	36	37.4	35.7
12:48:02	35.6	36	36.1	26.8	38	36.1	37.4	35.6
12:48:07	35.6	36	36.1	26.9	37.9	36	37.4	35.6
12:48:11	35.6	36	36.1	26.9	38	36	37.4	35.5
12:48:15	35.6	36	36.1	26.9	38	36	37.4	35.5
12:48:19	35.5	36	36	26.9	37.9	36	37.3	35.6
12:48:23	35.5	35.9	36.1	26.9	38	36	37.3	35.6
12:48:27	35.5	36	36.1	26.9	38	36	37.4	35.6
12:48:32	35.5	36	36.1	27.2	37.9	36	37.4	35.6
12:48:36	35.5	36	36.1	27.3	38	36.1	37.4	35.5
12:48:40	35.5	35.9	36.1	27.1	37.9	36	37.3	35.5
12:48:44	35.5	36	36.1	27.2	38	36	37.4	35.5
12:48:48	35.5	36	36.1	27.5	37.9	36	37.3	35.5
12:48:52	35.5	36	36.1	27.5	38	36	37.4	35.6
12:48:56	35.5	35.9	36.1	27.5	37.9	36	37.3	35.5
12:49:00	35.5	36	36.1	27.6	37.9	36	37.3	35.5
12:49:05	35.5	35.9	36.1	27.4	37.9	36	37.3	35.3
12:49:09	35.5	36	36.1	27.1	37.9	36	37.3	35.4
12:49:13	35.5	35.9	36.1	27	38	36	37.3	35.6
12:49:17	35.5	35.9	36.1	26.8	37.9	36	37.3	35.5
12:49:21	35.4	35.9	36.1	26.8	37.9	36	37.3	35.5
12:49:25	35.4	35.9	36.1	26.8	37.9	36	37.3	35.5
12:49:30	35.4	35.8	36.1	26.8	37.9	36	37.3	35.5
12:49:34	35.3	35.8	36.1	26.7	37.9	36	37.3	35.5
12:49:38	35.3	35.8	36.1	26.6	37.9	36	37.3	35.5
12:49:42	35.3	35.8	36.1	26.5	37.9	36	37.3	35.6
12:49:46	35.3	35.8	36.1	26.3	37.9	36	37.3	35.6
12:49:50	35.3	35.8	36.1	26.2	37.9	36	37.3	35.6
12:49:55	35.3	35.8	36.1	26.1	37.9	36	37.3	35.6
12:49:59	35.3	35.8	36.1	25.9	37.9	36	37.3	35.5
12:50:03	35.2	35.8	36.1	25.9	37.9	36	37.3	35.5
12:50:07	35.2	35.8	36.1	26	37.9	36	37.3	35.5
12:50:11	35.2	35.8	36.1	26	37.9	36	37.3	35.6
12:50:15	35.2	35.7	36.1	25.8	37.9	36	37.3	35.5
12:50:20	35.1	35.7	36.1	25.7	37.9	36	37.3	35.5
12:50:24	35.1	35.7	36.1	25.7	37.9	35.9	37.2	35.5
12:50:28	35.1	35.7	36.1	25.7	37.8	36	37.3	35.5
12:50:32	35.1	35.7	36.1	25.6	37.8	35.9	37.3	35.5
12:50:36	35.1	35.7	36.1	25.6	37.8	35.9	37.2	35.5
12:50:40	35.1	35.7	36.1	25.7	37.9	36	37.3	35.5
12:50:44	35	35.7	36.1	25.6	37.9	36	37.3	35.5
12:50:49	35	35.6	36.1	25.7	37.9	36	37.2	35.5
12:50:53	35	35.6	36	25.7	37.8	35.9	37.2	35.3
12:50:57	35	35.6	36	25.6	37.8	35.9	37.2	35.3
12:51:01	34.9	35.6	36	25.7	37.8	35.9	37.2	35.5
12:51:05	34.9	35.6	36	25.7	37.8	35.8	37.2	35.5
12:51:10	34.8	35.6	36	25.7	37.8	35.9	37.2	35.4

TABLE 1-continued

12:51:14	34.8	35.6	36	25.7	37.8	35.9	37.2	35.3
12:51:18	34.8	35.6	36.1	25.7	37.9	35.9	37.2	35.3
12:51:22	34.8	35.6	36	25.7	37.8	36	37.3	35.4
12:51:26	34.8	35.5	36	25.6	37.8	35.9	37.3	35.3
12:51:30	34.8	35.5	36	25.5	37.8	35.9	37.2	35.3
12:51:34	34.8	35.5	36	25.5	37.8	35.9	37.2	35.3
12:51:39	34.7	35.5	36	25.5	37.8	35.9	37.2	35.3
12:51:43	34.7	35.5	36	25.6	37.8	35.9	37.2	35.3
12:51:47	34.7	35.5	36	25.6	37.8	35.9	37.2	35.3
12:51:51	34.7	35.5	36	25.6	37.8	35.8	37.2	35.3
12:51:55	34.7	35.5	36	25.6	37.8	35.9	37.2	35.3
12:51:59	34.7	35.5	36	25.6	37.8	35.8	37.2	35.3
12:52:04	34.7	35.5	36	25.6	37.8	35.9	37.2	35.3
12:52:08	34.7	35.5	36	25.6	37.8	35.9	37.2	35.3
12:52:12	34.7	35.5	36	25.6	37.8	35.8	37.2	35.3
12:52:16	34.7	35.4	36	25.6	37.8	35.9	37.2	35.3
12:52:20	34.7	35.4	36	25.5	37.8	35.8	37.2	35.3
12:52:24	34.7	35.4	36	25.5	37.8	35.8	37.2	35.3
12:52:28	34.6	35.5	36	25.5	37.8	35.8	37.2	35.2
12:52:32	34.6	35.4	35.9	25.5	37.8	35.9	37.2	35.3
12:52:37	34.6	35.4	35.9	25.5	37.8	35.8	37.2	35.3
12:52:41	34.6	35.4	35.9	25.5	37.8	35.8	37.2	35.2
12:52:45	34.6	35.3	35.9	25.5	37.8	35.8	37.2	35.3
12:52:49	34.6	35.4	35.9	25.5	37.8	35.9	37.2	35.3
12:52:53	34.6	35.4	35.9	25.5	37.8	35.8	37.1	35.2
12:52:58	34.6	35.3	35.9	25.4	37.8	35.8	37.2	35.2
12:53:02	34.6	35.3	35.9	25.6	37.8	35.8	37.2	35.2
12:53:06	34.6	35.3	35.9	25.5	37.8	35.8	37.1	35.3
12:53:10	34.6	35.4	35.9	25.5	37.8	35.8	37.1	35.3
12:53:14	34.6	35.3	35.9	25.5	37.8	35.8	37.2	35.3
12:53:18	34.6	35.3	35.9	25.6	37.8	35.8	37.2	35.2
12:53:22	34.6	35.3	35.8	25.6	37.8	35.8	37.2	35.2
12:53:27	34.6	35.3	35.9	25.6	37.8	35.8	37.2	35.2
12:53:31	34.6	35.3	35.9	25.7	37.8	35.8	37.2	35.2
12:53:35	34.6	35.3	35.8	25.7	37.8	35.8	37.1	35.2
12:53:39	34.6	35.3	35.9	25.6	37.8	35.8	37.2	35.2
12:53:43	34.6	35.3	35.8	25.6	37.8	35.8	37.2	35.2
12:53:47	34.6	35.3	35.8	25.6	37.8	35.8	37.1	35.1
12:53:51	34.6	35.3	35.8	25.6	37.8	35.8	37.1	35.3
12:53:55	34.6	35.3	35.8	25.5	37.8	35.8	37.1	35.4
12:54:00	34.6	35.3	35.8	25.6	37.8	35.8	37.2	35.5
12:54:04	34.6	35.3	35.8	25.5	37.8	35.8	37.2	35.4
12:54:08	34.6	35.3	35.8	25.4	37.7	35.8	37.1	35.4
12:54:12	34.6	35.3	35.8	25.5	37.8	35.8	37.1	35.4
12:54:16	34.6	35.3	35.8	25.4	37.8	35.8	37.1	35.1
12:54:20	34.6	35.3	35.8	25.4	37.7	35.8	37.1	35
12:54:24	34.6	35.3	35.8	25.4	37.8	35.8	37.1	35
12:54:29	34.6	35.3	35.8	25.5	37.7	35.8	37.1	34.8
12:54:33	34.6	35.4	35.7	25.5	37.7	35.8	37.1	34.8
12:54:37	34.7	35.3	35.8	25.6	37.7	35.8	37.1	34.9
12:54:41	34.6	35.3	35.8	26	37.7	35.8	37.1	35
TIME	1:AIRWAY	1:EAR	MINUTES	HEAD-M	COOLING	NOSE		
12:26:52	30.3	32.3	0	38.1	0	26.6		
12:26:56	30	32.3	0.066667	38.1	0	27.9		
12:27:01	29.6	32.2	0.15	38.1	0	27		
12:27:05	29.1	32.2	0.216667	38.1	0	15		
12:27:09	28.9	32.3	0.283333	38.1	0	14		
12:27:13	29.3	32.3	0.35	38.06667	-0.03333	12.8		
12:27:17	29.8	32.3	0.416667	38	-0.1	12.9		
12:27:21	30.1	32.3	0.483333	37.96667	-0.13333	12.6		
12:27:26	29.7	32.3	0.566667	37.9	-0.2	11.8		
12:27:30	29.4	32.3	0.633333	37.9	-0.2	12		
12:27:34	29	32.3	0.7	37.83333	-0.26667	11.7		
12:27:38	28.9	32.3	0.766667	37.8	-0.3	12		
12:27:42	29.2	32.3	0.833333	37.73333	-0.36667	11.5		
12:27:46	29.7	32.3	0.9	37.7	-0.4	11.7		
12:27:50	29.7	32.3	0.966667	37.63333	-0.46667	11.8		
12:27:55	29.6	32.3	1.05	37.6	-0.5	11.7		
12:27:59	29.2	32.3	1.116667	37.53333	-0.56667	11.4		
12:28:03	28.8	32.2	1.183333	37.53333	-0.56667	11.2		
12:28:07	28.8	32.3	1.25	37.5	-0.6	11		
12:28:11	29	32.3	1.316667	37.43333	-0.66667	10.8		
12:28:15	29.5	32.3	1.383333	37.43333	-0.66667	10.8		
12:28:20	29.8	32.3	1.466667	37.43333	-0.66667	11		

TABLE 1-continued

12:28:24	29.6	32.3	1.533333	37.36667	-0.73333	11.2
12:28:28	29.3	32.3	1.6	37.26667	-0.83333	11.1
12:28:32	28.8	32.3	1.666667	37.33333	-0.76667	11.1
12:28:36	28.7	32.3	1.733333	37.26667	-0.83333	11.2
12:28:40	29	32.3	1.8	37.26667	-0.83333	11.1
12:28:44	29.5	32.3	1.866667	37.23333	-0.86667	11
12:28:49	29.9	32.3	1.95	37.2	-0.9	11.2
12:28:53	29.6	32.3	2.016667	37.13333	-0.96667	11.2
12:28:57	29.2	32.3	2.083333	37.1	-1	11.1
12:29:01	28.8	32.3	2.15	37.1	-1	11.2
12:29:05	29.2	32.3	2.216667	37.1	-1	11.2
12:29:09	29.2	32.3	2.283333	37.03333	-1.06667	11.3
12:29:13	29.6	32.3	2.35	37.03333	-1.06667	10.8
12:29:18	29.2	32.2	2.433333	37.06667	-1.03333	10.9
12:29:22	28.7	32.3	2.5	37.03333	-1.06667	10.5
12:29:26	28.5	32.3	2.566667	37.06667	-1.03333	10.8
12:29:30	28.6	32.3	2.633333	37	-1.1	10.8
12:29:34	29	32.3	2.7	37	-1.1	11
12:29:38	29.3	32.3	2.766667	36.96667	-1.13333	10.9
12:29:43	29.5	32.3	2.85	36.96667	-1.13333	10.9
12:29:47	29.2	32.3	2.916667	36.9	-1.2	10.8
12:29:51	28.8	32.3	2.983333	36.9	-1.2	10.9
12:29:55	28.5	32.3	3.05	36.9	-1.2	10.8
12:29:59	28.5	32.3	3.116667	36.83333	-1.26667	10.8
12:30:03	29	32.3	3.183333	36.86667	-1.23333	11.1
12:30:07	29.5	32.3	3.25	36.8	-1.3	10.9
12:30:12	29.4	32.3	3.333333	36.73333	-1.36667	10.9
12:30:16	29.1	32.3	3.4	36.76667	-1.33333	11
12:30:20	28.7	32.3	3.466667	36.73333	-1.36667	11.1
12:30:24	28.5	32.3	3.533333	36.7	-1.4	10.9
12:30:28	28.9	32.3	3.6	36.66667	-1.43333	11
12:30:32	29.4	32.3	3.666667	36.66667	-1.43333	11.1
2:30:36	29.5	32.3	3.733333	36.66667	-1.43333	11.1
12:30:41	29.1	32.3	3.816667	36.63333	-1.46667	10.8
12:30:45	28.7	32.3	3.883333	36.56667	-1.53333	11
12:30:49	28.4	32.3	3.95	36.56667	-1.53333	11.1
12:30:53	28.6	32.3	4.016667	36.56667	-1.53333	11
12:30:57	29.2	32.3	4.083333	36.56667	-1.53333	11
12:31:01	29.4	32.2	4.15	36.43333	-1.66667	11
12:31:06	29.2	32.3	4.233333	36.43333	-1.66667	11
12:31:10	28.7	32.2	4.3	36.46667	-1.63333	10.8
12:31:14	28.3	32.3	4.366667	36.46667	-1.63333	11
12:31:18	28.3	32.3	4.433333	36.46667	-1.63333	11
12:31:22	28.5	32.3	4.5	36.4	-1.7	11.1
12:31:26	29.1	32.2	4.566667	36.4	-1.7	11
12:31:30	29.2	32.3	4.633333	36.36667	-1.73333	11.3
12:31:35	28.9	32.2	4.716667	36.3	-1.8	11.3
12:31:39	28.5	32.2	4.783333	36.3	-1.8	11.2
12:31:43	28.2	32.2	4.85	36.3	-1.8	11.2
12:31:47	28.2	32.3	4.916667	36.3	-1.8	11.2
12:31:51	28.7	32.3	4.983333	36.3	-1.8	11
12:31:55	29.1	32.2	5.05	36.26667	-1.83333	10.9
12:31:59	29.1	32.2	5.116667	36.3	-1.8	11
12:32:04	28.7	32.2	5.2	36.2	-1.9	10.9
12:32:08	28.2	32.2	5.266667	36.2	-1.9	11
12:32:12	28	32.2	5.333333	36.2	-1.9	10.7
12:32:16	28.2	32.2	5.4	36.16667	-1.93333	11.3
12:32:20	28.7	32.2	5.466667	36.16667	-1.93333	11.1
12:32:24	29	32.2	5.533333	36.1	-2	10.8
12:32:29	28.7	32.2	5.616667	36.06667	-2.03333	10.8
12:32:33	28.3	32.2	5.683333	36.06667	-2.03333	10.7
12:32:37	28	32.2	5.75	36.06667	-2.03333	10.8
12:32:41	28	32.2	5.816667	36.03333	-2.06667	10.8
12:32:45	28.2	32.2	5.883333	36.03333	-2.06667	11
12:32:49	28.7	32.2	5.95	36	-2.1	11
12:32:53	28.9	32.2	6.016667	35.96667	-2.13333	11
12:32:58	28.7	32.2	6.1	35.96667	-2.13333	10.8
12:33:02	28.2	32.2	6.166667	35.93333	-2.16667	10.9
12:33:06	28.1	32.2	6.233333	35.93333	-2.16667	10.8
12:33:10	28.5	32.2	6.3	35.93333	-2.16667	10.8
12:33:14	29	32.2	6.366667	35.93333	-2.16667	10.6
12:33:18	29	32.2	6.433333	35.86667	-2.23333	10.9
12:33:23	28.8	32.2	6.516667	35.9	-2.2	10.8
12:33:27	28.4	32.2	6.583333	35.9	-2.2	10.8
12:33:31	28	32.2	6.65	35.86667	-2.23333	10.8
12:33:35	28.1	32.2	6.716667	35.86667	-2.23333	10.8

TABLE 1-continued

12:33:39	28.7	32.2	6.783333	35.83333	-2.26667	10.7
12:33:43	29	32.2	6.85	35.86667	-2.23333	11.1
12:33:47	28.7	32.2	6.916667	35.86667	-2.23333	10.8
12:33:52	28.4	32.2	7	35.86667	-2.23333	10.6
12:33:56	28.1	32.2	7.066667	35.86667	-2.23333	10.6
12:34:00	28	32.2	7.133333	35.9	-2.2	10.7
12:34:04	28.2	32.2	7.2	35.9	-2.2	10.7
12:34:08	28.6	32.2	7.266667	35.86667	-2.23333	10.7
12:34:12	29	32.2	7.333333	35.86667	-2.23333	10.7
12:34:16	28.8	32.2	7.4	35.86667	-2.23333	10.6
12:34:21	28.5	32.2	7.483333	35.83333	-2.26667	10.6
12:34:25	28.1	32.2	7.55	35.83333	-2.26667	10.4
12:34:29	28	32.2	7.616667	35.83333	-2.26667	10.6
12:34:33	28.2	32.2	7.683333	35.76667	-2.33333	10.6
12:34:37	28.6	32.2	7.75	35.76667	-2.33333	10.5
12:34:41	28.9	32.2	7.816667	35.76667	-2.33333	10.4
12:34:46	28.7	32.2	7.9	35.76667	-2.33333	10.5
12:34:50	28.4	32.2	7.966667	35.7	-2.4	10.7
12:34:54	28.2	32.2	8.033333	35.7	-2.4	10.5
12:34:58	27.9	32.2	8.1	35.7	-2.4	10.3
12:35:02	27.9	32.2	8.166667	35.66667	-2.43333	10.3
12:35:06	28.2	32.2	8.233333	35.7	-2.4	10.3
12:35:11	28.6	32.2	8.316667	35.63333	-2.46667	10.3
12:35:15	28.6	32.1	8.383333	35.6	-2.5	10.2
12:35:19	28.3	32.2	8.45	35.6	-2.5	10.3
12:35:23	28	32.2	8.516667	35.5	-2.6	10.3
12:35:27	27.8	32.1	8.583333	35.5	-2.6	10.2
12:35:31	27.8	32.1	8.65	35.5	-2.6	10.2
12:35:35	28.1	32.1	8.716667	35.53333	-2.56667	10.1
12:35:40	28.5	32.2	8.8	35.53333	-2.56667	10.1
12:35:44	28.6	32.2	8.866667	35.53333	-2.56667	9.9
12:35:48	28.5	32.2	8.933333	35.5	-2.6	10
12:35:52	28.2	32.2	9	35.46667	-2.63333	10
12:35:56	28	32.2	9.066667	35.4	-2.7	9.9
12:36:00	27.7	32.1	9.133333	35.46667	-2.63333	9.7
12:36:04	28.1	32.2	9.2	35.4	-2.7	9.9
12:36:09	28.4	32.2	9.283333	35.4	-2.7	9.8
12:36:13	28.6	32.1	9.35	35.4	-2.7	9.8
12:36:17	28.6	32.1	9.416667	35.36667	-2.73333	9.8
12:36:21	28.3	32.2	9.483333	35.36667	-2.73333	9.7
12:36:25	28	32.1	9.55	35.36667	-2.73333	9.8
12:36:29	27.8	32.2	9.616667	35.33333	-2.76667	9.7
12:36:34	27.8	32.1	9.7	35.33333	-2.76667	9.6
12:36:38	27.9	32.1	9.766667	35.33333	-2.76667	9.7
12:36:42	28.3	32.1	9.833333	35.26667	-2.83333	9.7
12:36:46	28.5	32.1	9.9	35.26667	-2.83333	9.6
12:36:50	28.3	32.1	9.966667	35.23333	-2.86667	9.5
12:36:54	28.1	32.1	10.03333	35.23333	-2.86667	9.6
12:36:58	27.8	32.1	10.1	35.2	-2.9	9.6
12:37:03	27.6	32.1	10.18333	35.23333	-2.86667	9.5
12:37:07	27.8	32.1	10.25	35.2	-2.9	9.5
12:37:11	28.2	32.1	10.31667	35.2	-2.9	9.6
12:37:15	28.2	32.1	10.38333	35.16667	-2.93333	9.6
12:37:19	28.1	32.1	10.45	35.2	-2.9	9.4
12:37:23	27.8	32.1	10.51667	35.16667	-2.93333	9.6
12:37:28	27.6	32.1	10.6	35.16667	-2.93333	9.6
12:37:32	27.7	32.1	10.66667	35.16667	-2.93333	9.3
12:37:36	28.1	32.1	10.73333	35.06667	-3.03333	9.4
12:37:40	28.3	32.1	10.8	35.1	-3	9.5
12:37:44	28.3	32.1	10.86667	35.1	-3	9.4
12:37:48	28	32.1	10.93333	35.06667	-3.03333	9.2
12:37:53	27.7	32.1	11.01667	35.06667	-3.03333	9.3
12:37:57	27.5	32.1	11.08333	35.06667	-3.03333	9.3
12:38:01	27.6	32.1	11.15	35.06667	-3.03333	9.3
12:38:05	28	32.1	11.21667	35.06667	-3.03333	9.3
12:38:09	28.2	32.1	11.28333	35.03333	-3.06667	9.3
12:38:13	28.1	32.1	11.35	35.03333	-3.06667	9.3
12:38:17	27.8	32.1	11.41667	35	-3.1	9.3
12:38:21	27.5	32.1	11.48333	35.03333	-3.06667	9.3
12:38:25	27.5	32.1	11.55	35.03333	-3.06667	9.3
12:38:30	27.7	32.1	11.63333	34.96667	-3.13333	9.3
12:38:34	28.1	32.1	11.7	35	-3.1	9.3
12:38:38	28.1	32.1	11.76667	34.96667	-3.13333	9.3
12:38:42	27.8	32.1	11.83333	34.93333	-3.16667	9.4
12:38:46	27.5	32.1	11.9	34.96667	-3.13333	9.5
12:38:50	27.3	32.1	11.96667	34.96667	-3.13333	9.4

TABLE 1-continued

12:38:55	27.5	32.1	12.05	34.96667	-3.13333	9.4
12:38:59	27.8	32.1	12.11667	34.93333	-3.16667	9.5
12:39:03	28.2	32.1	12.18333	34.96667	-3.13333	9.5
12:39:07	28.1	32.1	12.25	34.9	-3.2	9.4
12:39:11	27.8	32.1	12.31667	34.93333	-3.16667	9.4
12:39:15	27.5	32.1	12.38333	34.93333	-3.16667	9.5
12:39:19	27.3	32.1	12.45	34.93333	-3.16667	9.6
12:39:24	27.6	32.1	12.53333	34.9	-3.2	9.4
12:39:28	28	32.1	12.6	34.93333	-3.16667	9.3
12:39:32	28.2	32	12.66667	34.9	-3.2	9.5
12:39:36	28.1	32.1	12.73333	34.93333	-3.16667	9.5
12:39:40	27.8	32.1	12.8	34.86667	-3.23333	9.3
12:39:44	27.5	32	12.86667	34.86667	-3.23333	9.3
12:39:49	27.3	32	12.95	34.86667	-3.23333	9.3
12:39:53	27.6	32	13.01667	34.83333	-3.26667	9.3
12:39:57	28	32	13.08333	34.83333	-3.26667	9.2
12:40:01	28.1	32	13.15	34.83333	-3.26667	9.2
12:40:05	27.8	32	13.21667	34.83333	-3.26667	9.2
12:40:09	27.5	32	13.28333	34.83333	-3.26667	9.2
12:40:13	27.3	32.1	13.35	34.83333	-3.26667	9.2
12:40:18	27.3	32	13.43333	34.83333	-3.26667	9.1
12:40:22	27.8	32	13.5	34.83333	-3.26667	9.2
12:40:26	28.1	32	13.56667	34.83333	-3.26667	9.1
12:40:30	27.9	32	13.63333	34.83333	-3.26667	9.1
12:40:34	27.7	32	13.7	34.83333	-3.26667	9.1
12:40:38	27.3	32	13.76667	34.8	-3.3	9.2
12:40:42	27.2	32	13.83333	34.83333	-3.26667	9
12:40:47	27.5	32	13.91667	34.8	-3.3	8.9
12:40:51	27.9	32	13.98333	34.83333	-3.26667	8.8
12:40:55	28	32	14.05	34.8	-3.3	8.9
12:40:59	27.6	32	14.11667	34.76667	-3.33333	8.9
12:41:03	27.3	32	14.18333	34.76667	-3.33333	8.8
12:41:07	27.1	32	14.25	34.76667	-3.33333	8.8
12:41:12	27.4	32	14.33333	34.8	-3.3	8.8
12:41:16	28	32	14.4	34.76667	-3.33333	8.8
12:41:20	27.7	32	14.46667	34.76667	-3.33333	8.8
12:41:24	27.4	32	14.53333	34.76667	-3.33333	8.7
12:41:28	27.1	32	14.6	34.73333	-3.36667	8.8
12:41:32	27.2	32	14.66667	34.76667	-3.33333	8.8
12:41:36	27.7	32	14.73333	34.7	-3.4	8.9
12:41:41	27.9	32	14.81667	34.76667	-3.33333	8.8
12:41:45	27.7	32	14.88333	34.7	-3.4	8.8
12:41:49	27.4	32	14.95	34.73333	-3.36667	8.8
12:41:53	27.1	32	15.01667	34.73333	-3.36667	8.8
12:41:57	27.1	32	15.08333	34.76667	-3.33333	9
12:42:01	27.5	32	15.15	34.8	-3.3	8.8
12:42:05	27.8	32	15.21667	34.8	-3.3	8.8
12:42:10	27.6	32	15.3	34.83333	-3.26667	8.7
12:42:14	27.3	32	15.36667	34.8	-3.3	8.8
12:42:18	27	32	15.43333	34.9	-3.2	8.8
12:42:22	27.1	32	15.5	34.9	-3.2	8.8
12:42:26	27.3	32	15.56667	34.9	-3.2	8.6
12:42:30	27.7	32	15.63333	34.9	-3.2	8.5
12:42:35	27.7	32	15.71667	34.96667	-3.13333	8.6
12:42:39	27.5	32	15.78333	34.93333	-3.16667	8.5
12:42:43	27.1	32	15.85	34.96667	-3.13333	8.5
12:42:47	27	32	15.91667	34.93333	-3.16667	8.5
12:42:51	27.2	32	15.98333	34.93333	-3.16667	9.2
12:42:55	27.6	32	16.05	34.93333	-3.16667	9.1
12:42:59	27.7	32	16.11667	35	-3.1	9.1
12:43:04	27.5	32	16.2	35	-3.1	8.9
12:43:08	27.2	31.9	16.26667	34.93333	-3.16667	8.9
12:43:12	26.8	31.9	16.33333	34.96667	-3.13333	8.9
12:43:16	27	32	16.4	34.96667	-3.13333	8.9
12:43:20	27.4	32	16.46667	35.03333	-3.06667	8.7
12:43:24	27.8	31.9	16.53333	35.1	-3	8.7
12:43:28	27.5	31.9	16.6	35.16667	-2.93333	8.7
12:43:33	27.3	31.9	16.68333	35.2	-2.9	8.8
12:43:37	27.1	31.9	16.75	35.23333	-2.86667	8.7
12:43:41	26.8	31.9	16.81667	35.3	-2.8	8.7
12:43:45	27.1	31.9	16.88333	35.33333	-2.76667	8.7
12:43:49	27.5	31.9	16.95	35.33333	-2.76667	8.8
12:43:53	27.6	31.9	17.01667	35.33333	-2.76667	8.7
12:43:58	27.5	31.9	17.1	35.26667	-2.83333	8.9
12:44:02	27.1	32	17.16667	35.36667	-2.73333	8.8
12:44:06	26.9	32	17.23333	35.4	-2.7	8.8

TABLE 1-continued

12:44:10	26.8	31.9	17.3	35.4	-2.7	8.8
12:44:14	27.2	31.9	17.36667	35.43333	-2.66667	8.7
12:44:18	27.5	31.9	17.43333	35.46667	-2.63333	8.7
12:44:22	27.6	31.9	17.5	35.46667	-2.63333	8.7
12:44:27	27.3	31.9	17.58333	35.53333	-2.56667	8.6
12:44:31	27.1	31.9	17.65	35.5	-2.6	8.6
12:44:35	26.8	31.9	17.71667	35.53333	-2.56667	8.6
12:44:39	26.8	31.8	17.78333	35.5	-2.6	8.4
12:44:43	27.2	31.8	17.85	35.53333	-2.56667	8.5
12:44:47	27.5	31.9	17.91667	35.53333	-2.56667	8.5
12:44:52	27.5	31.8	18	35.5	-2.6	8.6
12:44:56	27.1	31.8	18.06667	35.53333	-2.56667	8.8
12:45:00	26.8	31.9	18.13333	35.53333	-2.56667	8.8
12:45:04	27	31.8	18.2	35.6	-2.5	8.7
12:45:08	27.4	31.8	18.26667	35.6	-2.5	8.5
12:45:12	27.5	31.8	18.33333	35.6	-2.5	8.5
12:45:17	27.3	31.8	18.41667	35.6	-2.5	8.5
12:45:21	27	31.8	18.48333	35.63333	-2.46667	8.5
12:45:25	26.7	31.8	18.55	35.66667	-2.43333	8.3
12:45:29	26.8	31.8	18.61667	35.66667	-2.43333	8.4
12:45:33	27.4	31.8	18.68333	35.66667	-2.43333	8.6
12:45:37	27.5	31.8	18.75	35.7	-2.4	8.5
12:45:41	27.2	31.8	18.81667	35.63333	-2.46667	8.5
12:45:46	27	31.8	18.9	35.6	-2.5	8.6
12:45:50	26.7	31.8	18.96667	35.63333	-2.46667	8.6
12:45:54	26.8	31.7	19.03333	35.6	-2.5	8.5
12:45:58	27.3	31.8	19.1	35.63333	-2.46667	8.5
12:46:02	27.6	31.8	19.16667	35.66667	-2.43333	8.5
12:46:06	27.3	31.8	19.23333	35.7	-2.4	8.6
12:46:10	27	31.8	19.3	35.7	-2.4	8.5
12:46:15	26.8	31.8	19.38333	35.66667	-2.43333	8.3
12:46:19	26.9	31.8	19.45	35.73333	-2.36667	8.4
12:46:23	27.2	31.8	19.51667	35.73333	-2.36667	8.4
12:46:27	27.6	31.8	19.58333	35.76667	-2.33333	8.5
12:46:31	27.4	31.8	19.65	35.76667	-2.33333	8.5
12:46:35	27.2	31.8	19.71667	35.8	-2.3	8.4
12:46:40	26.9	31.8	19.8	35.8	-2.3	8.3
12:46:44	26.7	31.8	19.86667	35.8	-2.3	8.2
12:46:48	27.1	31.8	19.93333	35.8	-2.3	8.2
12:46:52	27.5	31.8	20	35.83333	-2.26667	8.1
12:46:56	27.5	31.8	20.06667	35.8	-2.3	8.1
12:47:00	27.2	31.8	20.13333	35.83333	-2.26667	8.2
12:47:04	27	31.8	20.2	35.8	-2.3	8.3
12:47:08	26.7	31.8	20.26667	35.8	-2.3	8.2
12:47:13	27	31.8	20.35	35.8	-2.3	8.1
12:47:17	27.2	31.8	20.41667	35.83333	-2.26667	8.1
12:47:21	27.5	31.8	20.48333	35.83333	-2.26667	8.2
12:47:25	27.3	31.8	20.55	35.8	-2.3	8.4
12:47:29	27.1	31.8	20.61667	35.86667	-2.23333	8.3
12:47:33	26.8	31.8	20.68333	35.8	-2.3	8.3
12:47:37	26.7	31.8	20.75	35.86667	-2.23333	8.2
12:47:42	27	31.8	20.83333	35.83333	-2.26667	8.2
12:47:46	27.3	31.8	20.9	35.86667	-2.23333	8.2
12:47:50	27.5	31.8	20.96667	35.8	-2.3	8.2
12:47:54	27.5	31.8	21.03333	35.83333	-2.26667	8.2
12:47:58	27.2	31.8	21.1	35.9	-2.2	8.2
12:48:02	26.9	31.8	21.16667	35.9	-2.2	8.2
12:48:07	26.7	31.8	21.25	35.9	-2.2	8.2
12:48:11	26.8	31.8	21.31667	35.9	-2.2	8.1
12:48:15	27.1	31.8	21.38333	35.9	-2.2	8.2
12:48:19	27.5	31.8	21.45	35.83333	-2.26667	8.1
12:48:23	27.3	31.8	21.51667	35.83333	-2.26667	8.1
12:48:27	27.1	31.8	21.58333	35.86667	-2.23333	8.2
12:48:32	26.8	31.8	21.66667	35.86667	-2.23333	11.1
12:48:36	26.7	31.8	21.73333	35.86667	-2.23333	12.8
12:48:40	27.3	31.8	21.8	35.83333	-2.26667	12.7
12:48:44	27.6	31.8	21.86667	35.86667	-2.23333	13.2
12:48:48	27.4	31.7	21.93333	35.86667	-2.23333	13.8
12:48:52	27	31.7	22	35.86667	-2.23333	14
12:48:56	26.7	31.7	22.06667	35.83333	-2.26667	14.5
12:49:00	26.7	31.7	22.13333	35.86667	-2.23333	10
12:49:05	27.1	31.7	22.21667	35.83333	-2.26667	9.6
12:49:09	27.5	31.7	22.28333	35.86667	-2.23333	8.9
12:49:13	27.3	31.7	22.35	35.83333	-2.26667	8.6
12:49:17	27.2	31.7	22.41667	35.83333	-2.26667	8.5
12:49:21	26.9	31.8	22.48333	35.8	-2.3	8.6

TABLE 1-continued

12:49:25	26.8	31.8	22.55	35.8	-2.3	8.5
12:49:30	27.2	31.7	22.63333	35.76667	-2.33333	8.4
12:49:34	27.6	31.7	22.7	35.73333	-2.36667	8.4
12:49:38	27.5	31.7	22.76667	35.73333	-2.36667	8.5
12:49:42	27.4	31.7	22.83333	35.73333	-2.36667	8.4
12:49:46	27	31.7	22.9	35.73333	-2.36667	8.3
12:49:50	26.8	31.7	22.96667	35.73333	-2.36667	8.3
12:49:55	27	31.7	23.05	35.73333	-2.36667	8.3
12:49:59	27.4	31.7	23.11667	35.73333	-2.36667	8.4
12:50:03	27.6	31.7	23.18333	35.7	-2.4	8.4
12:50:07	27.5	31.7	23.25	35.7	-2.4	8.3
12:50:11	27.2	31.7	23.31667	35.7	-2.4	8.3
12:50:15	26.8	31.7	23.38333	35.66667	-2.43333	8.3
12:50:20	26.8	31.7	23.46667	35.63333	-2.46667	8.3
12:50:24	27.2	31.7	23.53333	35.63333	-2.46667	8.3
12:50:28	27.6	31.7	23.6	35.63333	-2.46667	8.2
12:50:32	27.5	31.7	23.66667	35.63333	-2.46667	8.2
12:50:36	27.3	31.7	23.73333	35.63333	-2.46667	8.3
12:50:40	27	31.7	23.8	35.63333	-2.46667	8.3
12:50:44	26.8	31.7	23.86667	35.6	-2.5	8.2
12:50:49	27.1	31.7	23.95	35.56667	-2.53333	8.5
12:50:53	27.5	31.6	24.01667	35.53333	-2.56667	8.3
12:50:57	27.5	31.6	24.08333	35.53333	-2.6667	8.3
12:51:01	27.3	31.6	24.15	35.5	-2.6	8.2
12:51:05	27	31.7	24.21667	35.5	-2.6	8.2
12:51:10	26.8	31.7	24.3	35.46667	-2.63333	8.2
12:51:14	26.9	31.7	24.36667	35.46667	-2.63333	8.2
12:51:18	27.3	31.7	24.43333	35.5	-2.6	8.1
12:51:22	27.6	31.7	24.5	35.46667	-2.63333	8.2
12:51:26	27.4	31.6	24.56667	35.43333	-2.66667	8.2
12:51:30	27.1	31.7	24.63333	35.43333	-2.66667	8.2
12:51:34	26.9	31.7	24.7	35.43333	-2.66667	8.1
12:51:39	26.8	31.7	24.78333	35.4	-2.7	8.1
12:51:43	27.1	31.6	24.85	35.4	-2.7	8
12:51:47	27.5	31.7	24.91667	35.4	-2.7	8
12:51:51	27.5	31.6	24.98333	35.4	-2.7	8
12:51:55	27.2	31.6	25.05	35.4	-2.7	8
12:51:59	27.1	31.7	25.11667	35.4	-2.7	8.1
12:52:04	26.8	31.6	25.2	35.4	-2.7	8
12:52:08	26.9	31.6	25.26667	35.4	-2.7	8
12:52:12	27.3	31.6	25.33333	35.4	-2.7	8.1
12:52:16	27.6	31.7	25.4	35.36667	-2.73333	8.1
12:52:20	27.4	31.6	25.46667	35.36667	-2.73333	8.1
12:52:24	27.1	31.6	25.53333	35.36667	-2.73333	8
12:52:28	26.8	31.6	25.6	35.36667	-2.73333	8
12:52:32	27.1	31.6	25.66667	35.3	-2.8	8.1
12:52:37	27.5	31.6	25.75	35.3	-2.8	8.1
12:52:41	27.4	31.6	25.81667	35.3	-2.8	8.1
12:52:45	27.2	31.6	25.88333	35.26667	-2.83333	8
12:52:49	26.9	31.6	25.95	35.3	-2.8	8
12:52:53	26.8	31.6	26.01667	35.3	-2.8	8.1
12:52:58	27	31.6	26.1	35.26667	-2.83333	8
12:53:02	27.4	31.6	26.16667	35.26667	-2.83333	7.9
12:53:06	27.5	31.6	26.23333	35.26667	-2.83333	7.9
12:53:10	27.4	31.6	26.3	35.3	-2.8	8.1
12:53:14	27.1	31.6	26.36667	35.26667	-2.83333	8
12:53:18	26.9	31.6	26.43333	35.26667	-2.83333	8
12:53:22	26.8	31.6	26.5	35.23333	-2.86667	8
12:53:27	27.1	31.6	26.58333	35.26667	-2.83333	8
12:53:31	27.5	31.6	26.65	35.26667	-2.83333	7.9
12:53:35	27.5	31.6	26.71667	35.23333	-2.86667	8
12:53:39	27.3	31.6	26.78333	35.26667	-2.83333	8
12:53:43	27	31.6	26.85	35.23333	-2.86667	8
12:53:47	26.8	31.6	26.91667	35.23333	-2.86667	8
12:53:51	26.9	31.6	26.98333	35.23333	-2.86667	8
12:53:55	27.2	31.6	27.05	35.23333	-2.86667	7.9
12:54:00	27.5	31.6	27.13333	35.23333	-2.86667	8
12:54:04	27.4	31.6	27.2	35.23333	-2.86667	8
12:54:08	27.1	31.6	27.26667	35.23333	-2.86667	7.8
12:54:12	26.8	31.6	27.33333	35.23333	-2.86667	7.8
12:54:16	26.8	31.6	27.4	35.23333	-2.86667	7.8

TABLE 1-continued

12:54:20	27.1	31.6	27.46667	35.23333	-2.86667	8
12:54:24	27.5	31.6	27.53333	35.23333	-2.86667	8
12:54:29	27.5	31.6	27.61667	35.23333	-2.86667	7.8
12:54:33	27.3	31.6	27.68333	35.23333	-2.86667	7.8
12:54:37	27	31.6	27.75	35.26667	-2.83333	7.4
12:54:41	26.8	31.6	27.81667	35.23333	-2.86667	8.7

[0178] FIG. 39 illustrates nasal catheter 910 for non-invasive cerebral and systemic cooling of the nasal cavity. The nasal catheter has a rounded sealed tip 912 on the distal end, which provides a smooth surface to avoid damaging sensitive tissues. Tip 912 may be sealed by selective melting of the distal end of the catheter. In use, catheter 910 is intended to be placed in the nares of the nose, so that a spray outlet (not shown) may be directed at the desired structures of the nasal cavity, specifically the nasal conchae. The spray nozzle on the distal end of nasal catheter 10 is designed so as to cause the spray to spread in a pattern which will allow the gas/liquid mixture to contact as much of the desired tissues as possible. By doing this, any mechanical trauma due to a concentrated high velocity jet should be minimized.

[0179] FIGS. 43A-C depict several possible designs for the spray nozzle for creating varying spread spray patterns. FIG. 43A shows nasal catheter 910 wherein the spray nozzle has been formed by drilling multiple holes 940 along the outer wall of nasal catheter 910. In use, this pattern produces will produce a broad, flat spray perpendicular to the axis of the catheter. This pattern may be further customized by drilling corresponding holes in the opposite side of the catheter wall (not show), or by changing the size, location and number of holes drilled in the catheter outer wall. In addition, it may also be possible to include a hole in the catheter tip 12 (hole not shown), to produce some additional flow in the axial direction.

[0180] FIG. 43B shows nasal catheter 910, wherein the spray nozzle has been formed by cutting a rectangular slit 942 in tip 912 of catheter 910. In use, this pattern produces a fan shaped spray centered along the axial direction of the catheter. Here, the width and length of slit 942 will dictate the character of the spray. The pattern may, therefore be customized by varying the width and length of slit 942. In addition, the symmetry of the spray may be altered by cutting slit 942 to extend farther down one side catheter 910 than the other. Alternatively, the spray pattern may be altered by adding one or more additional slits of varying widths and lengths (not shown).

[0181] FIG. 43C shows a nasal catheter 910, wherein the spray nozzle has been formed by making an angled straight cut 944 or a curved cut (not shown) in the side of catheter 910, including a portion of catheter tip 912. In use, this skived cut produces a wide 'fan' shaped spray which covers a broad angle from the perpendicular to the axial directions of catheter 910. In addition, any of the patterns depicted in FIGS. 43A-C could also be combined to further disperse the spray. For example, holes could be cut along the length of a skived tip catheter to cover a wider area, or a slit could be cut in the tip of a the drilled hole catheter to enhance flow in the axial direction.

[0182] FIG. 40 shows a dual-lumen mixing catheter 914 connected to two nasal catheters 910 for separately delivering a liquid and a gas to the proximal end of each nasal catheter

910. In use, nasal catheters 910 will be placed a distance apart appropriate for the nares of the desired patient, and made a length appropriate for administration at the targeted tissues. The dual-lumen mixing catheter 914 comprises an upper lumen 918 and a lower lumen 920 used to separately deliver the liquid and the gas. This mixing catheter may be constructed as a single ended device, or made into a loop (not shown) similar to a standard nasal cannula for oxygen therapy. The 'loop' configuration aids in placement on the patient, as it may be routed over and behind the ears to hold it in place. The loop configuration also helps ensure equal flow when two nasal catheters are used.

[0183] Nasal catheter 910 is connected to mixing catheter 914 by a connecting tube 916. Connecting tube 916 is a hollow, open ended tube for attaching nasal catheter 910 to mixing catheter 914 and for placing nasal catheter 910 in fluid communication with at least the lower lumen 920 of mixing catheter 914. It can be made from metal 'hypodermic' tubing, or a suitable plastic. As shown in FIG. 41, the connecting tube 916 has an outer diameter sized to fit tightly in the lumen of nasal catheter 910 and thus form a seal between nasal catheter 910 and mixing catheter 914. Once assembled, an over layer of glue or other compound such as silicone may be used to ensure a durable connection and smooth texture for patient comfort. In use, open ended, hollow tube 924 of connecting tube 916 places the lumen of nasal catheter 910 in fluid communication with the lower lumen 920 of mixing catheter 910. In this configuration, the gas is supplied through the lower lumen 920 of the dual lumen tubing 914. The gas flows through the lower lumen 920 and up through the lumen 924 of connecting tube 916 into the nasal catheter(s) 910. At the same time, the liquid is supplied through the upper lumen 918 of mixing catheter 914. The liquid passes into the lumen 924 of connecting tube 916 via a small hole 922 drilled in the wall of connecting tube 916. The inner diameter of the tube and the size of fluid hole 922 are important parameters in the optimization of the spray pattern.

[0184] At this point, the gas is moving at a high velocity, and the liquid experiences high shear forces, breaking the stream into small droplets that then flow through the lumen of nasal catheter 910 and are delivered as a spray to the patient's nasal cavity through the spray nozzle 915.

[0185] FIG. 42 illustrates an alternate embodiment of a mixing catheter. The dual lumen tubing 914 is used as above, and catheter tip 912, including a spray nozzle 915 is also as previously described. In this embodiment, however, the mixing of the air and liquid occurs very near tip 912. The liquid is delivered through lower lumen 930 and the gas is delivered through upper lumen 928 of mixing catheter 914. The nasal catheter is secured directly to an aperture in upper lumen 928 so that a small diameter liquid delivery tube 926 extending perpendicularly from lower lumen 930 of mixing catheter 914 is positioned inside the lumen of the nasal catheter 910. Liquid tube 926 is a hollow, open ended tube extending

through the lumen of nasal catheter **910** to the distal region of nasal catheter **910**. Liquid tube **926** has an outer diameter smaller than the inner diameter of nasal catheter **910** and smaller than the aperture connecting nasal catheter **910** to mixing catheter **914**. In use, the liquid flows through lumen **927** of liquid tube **926** while the gas flows through upper lumen **928** and enters nasal catheter **910** via the annular space **929** between liquid tube **926** and the inside diameter of catheter **910**. Turbulence and other flow effects, such as Bernoulli pressure, at the end of liquid tube **926** cause the fluid to be broken up into small droplets. This design requires less pressure to drive the liquid, and may aid in matching the liquid and gas flows.

[0186] FIG. 44 illustrates an alternative embodiment of a gas and liquid delivery system that may be attached the proximal end of the nasal catheter whereby the liquid and the gas are delivered to the catheter through their own tubes **950** and **952** and mixed at the point of administration to the patient, rather than prior to use. This ensures that even an unstable spray can be delivered to the desired region. Furthermore, because the liquid begins to evaporate immediately upon contact with the gas, mixing at the point of use in the patient will ensure efficient use of all available cooling. As seen in FIG. 44, the mixing device may comprise a mixing block **954** including at least two input flow channels **950** and **952** and a single output flow channel **956**. Mixing block **954** may be machined from metal, plastic, or molded from plastic. The two input flow channels **950** and **952** may be connected to two separate tubes containing a liquid and a compressed gas. Input channels **950** and **952** may then be joined in mixing block **954** so that the liquid and gas carried by the input tubes will be combined, after which the combined liquid/gas mixture may then flow through output channel **956**. The nasal catheter may be attached to output channel **956** for delivery of the combined liquid/gas mixture to the patient's nasal cavity.

[0187] FIG. 46 illustrates an alternative nasal catheter for cooling the nasal cavity with cold saline. Here, nasal catheter **990** includes an elongate tubular member, operably sized to extend into the patient's nasopharynx with expandable member **992** mounted on the distal end of catheter **990**. In use, nasal catheter **990** is inserted into one of the patient's nostrils and positioned in the nasopharynx. Once positioned in the nasopharynx, expandable member **992** is expanded to conform to the nasopharynx and form a seal isolating the nasal cavity from the rest of the patient's airways. Once isolated, cold saline is injected into one of the patient's nostrils and circulated through the nasal cavity to allow for rapid cooling of the patient's head. Expandable member **992** prevents the saline from entering the patient's other airways. The saline may then be allowed to run out the patient's other nostril or may be suctioned from the patient's nasal cavity from a suction port (not shown) proximal to expandable member **992**. In addition, a second nasal catheter (not shown), also comprising an elongate tubular member with an expandable member mounted on the distal end, may be inserted in the patient's second nostril. Here, the balloons may be positioned on either side of the nasal cavity before the septum and expanded to isolate the nasal cavity from the rest of the patient's airways.

[0188] FIGS. 47-48 show an alternative nasal catheter for cooling the nasal cavity with a cold liquid. Here, nasal catheter **990** includes an elongate tubular member, operably sized to extend into the patient's nasopharynx and at least one expandable member **992** mounted near the distal end of the elongate tubular member and two expandable members

991a-b mounted near the proximal end of catheter **990**. In use, nasal catheter **990** is inserted into one of the patient's nostrils and positioned in the nasopharynx. Once positioned in the nasopharynx, expandable member **992** is expanded to conform to the nasopharynx and form a seal isolating the nasal cavity from the rest of the patient's airways and the expandable members **991a-b** at the proximal end are positioned in the patient's nostrils to seal the patient's nasal cavity. Alternatively, as depicted in FIG. 48, the distal end may have two expandable members **992a-b** that may be positioned at the posterior aspect of the nasal cavity to isolate the nasal cavity from the pharynx. Catheter **990** also has openings **994** and **995** at the distal and proximal ends, respectively, to provide a breathing passage while the nasal cavity is sealed. Once the nasal cavity is isolated, a cold fluid may be delivered to the nasal cavity via delivery lumen **997**, which is in fluid communication with port **996**. Alternatively, a tube comprising a spray nozzle (not shown) may be inserted in the delivery lumen **997** to deliver a liquid spray to the nasal cavity.

[0189] Expandable members **992a-b** and **991a-b** at the distal and proximal ends of catheter **990** prevent non-vaporized fluid from leaking into the throat or running out the patient's nostrils. The non-vaporized liquid may then be suctioned from the nasal cavity via suction lumen **999**, which is in fluid communication with port **998**. This liquid may be discarded or alternatively it may be recycled for successive use. Because there is a dedicated lumen for delivery and suction, however, delivery of the cooled liquid to the nasal cavity does not need to be interrupted.

Convective Cooling in the Nasal Cavity

[0190] In another aspect of this invention, a catheter with a flexible balloon having a chamber filled with a cooling liquid can be used to cool the brain via the nasal cavity. As seen in FIG. 22A, assembly **200** includes flexible balloon **204** that is mounted circumferentially around catheter **202**. Catheter **202** has ports **211**, **212** at the proximal and distal ends and lumen **210** extending therebetween that enables the patient to breathe while the catheter is in use. Ports **211**, **212** and lumen **210** are in fluid communication with the patient's nasopharynx, pharynx, larynx, and/or esophagus. Catheter **202** is approximately 8 cm in length, alternatively approximately 10 cm in length, alternatively approximately 12 cm in length, alternatively approximately 14 cm in length, alternatively approximately 16 cm in length, alternatively approximately 18 cm in length, alternatively approximately 20 cm in length. Lumens **206**, **208** are in fluid communication with the chamber of the flexible balloon **204** through ports **207**, **209** located at the distal ends. At their proximal ends, lumens **204**, **206** are connected to a refrigerated pump (not shown) that is capable of recycling a cooling fluid through the chamber of the flexible balloon **204**.

[0191] In use, as seen in FIG. 22B, assembly **200** is inserted into the nasal cavity through the patient's nostril such that flexible balloon **204** is within the nasal cavity and the distal end of catheter **202** extends through the narices to the nasopharyngeal region of the nasal cavity. A cooling liquid or fluid can then be used to inflate or infuse the chamber of flexible balloon **204** to a sufficient pressure such that flexible balloon **204** expands and is in contact with a substantial portion of the nasal cavity. The cooling fluid may then be recirculated through the chamber of flexible balloon **204** via lumens **206**, **208** and a refrigerated bath/pump (not shown). Optionally, the cooling fluid can be withdrawn or suctioned

back out of flexible balloon **204** at a rate sufficient to induce or maintain a desired balloon pressure or brain temperature. Additionally, a second assembly can also be inserted into the other nostril such that maximum cooling can be obtained. The cooling of the brain would occur by convection or heat exchange from the cold liquid in the chamber of the balloon to the warm nasal cavity. Lumen **210** of catheter **202** allows the patient to breathe through his nose after the flexible balloon **204** is inflated. Alternatively, when the patient is getting oxygen through alternative means, other medical devices can be passed through lumen **210**. These medical devices include, but are not limited to, oxygen tube, nasogastric tube, fiber optics, laryngoscope, pH probes, and esophageal manometry.

[0192] In an alternative embodiment, a flexible balloon having a chamber filled with a cooling liquid can be used to cool the brain via the nasal cavity. As seen in FIG. 23A, assembly **250** includes flexible balloon **254** that has a chamber that is in fluid communication with lumens **256**, **258** of elongate tubular members **264**, **268** through ports **257**, **259** located at their distal ends. At their proximal ends, elongate tubular members **264**, **268** may be connected to cooler **260** and pump **262** that infuse and/or recirculate the cooling liquid through lumens **256**, **258** and the chamber of flexible balloon **254**. Alternatively, elongate tubular members **264**, **268** may be connected to a refrigerated pump (not shown) that is capable of pumping and/or recirculating the cooling fluid.

[0193] In use, as seen in FIG. 23B, assembly **250** is inserted into the nasal cavity through a nostril such that flexible balloon **254** is within the nasal cavity **270**. A cooling fluid can then be used to inflate flexible balloon **254** to a sufficient pressure such that flexible balloon **254** expands and is in contact with a substantial portion of the nasal cavity. The cooling fluid is then recirculated through flexible balloon **254** via lumens **256**, **258**, cooler **260**, and pump **262**. Optionally, the cooling fluid can be suctioned back out of flexible balloon **254** at a rate sufficient to induce or maintain a desired balloon pressure or brain temperature. Additionally, a second assembly can also be inserted into the other nostril such that maximum cooling can be obtained. The cooling of the brain would occur by convection or heat exchange from the cold liquid in the balloon to the warm nasal cavity.

[0194] In an alternative embodiment, a flexible balloon having a chamber filled with a cooling liquid can be used to cool the brain via the nasal cavity. As seen in FIG. 29, assembly **700** includes flexible balloon **702** that has a chamber **703** that is in fluid communication with lumen **706** of elongate tubular member **708** through port **710** located at its distal end. At a point outside of chamber **703**, elongate tubular member **708** branches into two elongate tubular members **715** and **720** having lumens **716** and **721**, respectively. Elongate tubular members **720** and **715** are in communication with each other through pump **722**, e.g., a piston pump, and cooler **724**, located at or near the proximal ends of elongate tubular members **715** and **720**. Cooler **724** and pump **722** infuse and/or recirculate the cooling liquid through lumens **716** and **721** and the chamber of flexible balloon **254**. This single lumen design may allow for faster inflation and deflation. Alternatively, elongate tubular members **715** and **720** may be connected to a refrigerated pump (not shown) that is capable of pumping and/or recirculating the cooling fluid.

[0195] In use, assembly **700** is inserted into the nasal cavity through a nostril such that flexible balloon **702** is within the nasal cavity. A cooling fluid can then be used to inflate flexible balloon **702** to a sufficient pressure such that flexible balloon

702 expands and is in contact with a substantial portion of the nasal cavity. The cooling fluid is then recirculated through flexible balloon **702** via lumens **706**, **716**, and **721**, cooler **722**, and pump **724**. For instance, cooling liquid may be withdrawn from chamber **703** by having pump **722** withdraw the cooling liquid through lumens **706** and **721** of elongate tubular members **708** and **720**, respectively. Cooling liquid can then be pumped into cooler for further cooling and then pumped back into chamber **703** through lumens **716** and **706** of elongate tubular members **715** and **708**. In order to optimize cooling and minimize tissue damage, it may be desirable to continuously inflate and deflate flexible balloon **702**. Additionally, a second assembly can also be inserted into the other nostril such that maximum cooling can be obtained. The cooling of the brain would occur by convection or heat exchange from the cold liquid in the balloon to the warm nasal cavity.

[0196] In an alternative embodiment, a flexible balloon having a chamber filled with a cooling liquid and a cold finger inside of a second balloon can be used to cool the brain via the nasal cavity. As seen in FIG. 27, assembly **600** includes flexible balloon **602** that has chamber **603** that is in fluid communication with port **604**. A cooling liquid, such as water or saline, can be infused into chamber **603** through port **604**. A second balloon **605** containing a cold probe **607** is contained within chamber **603** to cool the liquid inside flexible balloon **602**. A cooling agent, such as Freon or other PFC, that is approximately 0°C ., alternatively approximately -1°C ., alternatively approximately -2°C ., alternatively approximately -3°C ., alternatively between about -5°C . and 5°C ., alternatively between about -5°C . and 0°C ., will be flowed through cold probe **607**. The flow rate of the cooling agent will depend on the type used. The flow rate will be chosen to produce between about 150 and about 300 watts. Additionally, cold probe **607** may be connected to cooler **610**. Second balloon **605** may be in fluid communication with a port and allowed to vent to the atmosphere (not shown). Alternatively, second balloon **605** may be in fluid communication with a compressor **612** through elongate tubular member **614** to circulate the cooling liquid.

[0197] Cold probe **607** may also have fins surrounding the cold probe (not shown) to increase the surface area of the probe. Alternatively, a heat pipe could be used in place of the cold probe. The heat pipe could be filled with a gas such as freon or ammonia, or alternatively, the heat pipe could be connected to a circulating cooling liquid reservoir or other cooling source (such as a block of ice).

[0198] In use, assembly **600** is inserted into the nasal cavity through the patient's nostril such that flexible balloon **602** is within the nasal cavity. A cooling fluid can then be used to inflate flexible balloon **602** to a sufficient pressure such that flexible balloon **602** expands and is in contact with a substantial portion of the nasal cavity. The cooling agent will then be circulated into second balloon **605** via port **608** at the distal end of cold probe **607** and elongate tubular member **614**. Alternatively, the cooling agent may not be recirculated, but rather be vented out of a port in second balloon **605** (not shown). Additionally, the fluid in the balloon can be agitated to prevent freezing. This may be accomplished by moving cold probe **607** or pulsing the infusion of the cooling agent into second balloon **605**. Additionally, a second assembly can also be inserted into the other nostril such that maximum cooling can be obtained. The cooling of the brain would occur

by convection or heat exchange from the cold liquid in the balloon to the warm nasal cavity.

[0199] In an alternative embodiment, a flexible balloon having a chamber filled with a cooling liquid and a cold finger can be used to cool the brain via the nasal cavity. As seen in FIG. 28A, assembly 650 includes flexible balloon 652 that has chamber 653 that is in fluid communication with port 654 containing a filter 656. A cooling liquid, such as water or saline, can be infused into chamber 653 through lumen 658 of elongate tubular member 659. A cooling agent, such as Freon or other PFC, that is approximately 0° C., alternatively approximately -1° C., alternatively approximately -2° C., alternatively approximately -3° C., alternatively between about -5° C. and 5° C., alternatively between about -5° C. and 0° C., will be flowed through cold probe 657. Additionally, cold probe 657 may be connected to cooler (not shown). The cooling agent will flow out of port 658 of cold probe 657 and produce gas bubbles 660 in the cooling liquid in chamber 653, thereby cooling the liquid further and agitating the liquid to aid in mixing the liquid throughout chamber 653. The gas bubbles can exit chamber 653 through port 654 with air venting filter 656, which allows for the release of gas and not liquid. Additionally, an additional elongate tubular member (not shown) can be inserted into flexible balloon 652 such that a lumen of the elongate tubular member is in fluid communication with chamber 653 of balloon 652. An additional gas, such as oxygen or nitrogen, can be delivered into the cooling liquid to aid in the mixing and agitation of the cooling liquid within the chamber.

[0200] In use, with the patient lying on his back, assembly 650 is inserted into the nasal cavity through the patient's nostril such that flexible balloon 652 is within nasal cavity 670. A cooling fluid can then be used to inflate flexible balloon 652 to a sufficient pressure such that flexible balloon 652 expands and is in contact with a substantial portion of nasal cavity 670. The cooling agent will flow out of port 658 of cold probe 657 and produce gas bubbles 660 in the cooling liquid in chamber 653, thereby cooling the liquid further and agitating the liquid to aid in mixing the liquid throughout chamber 653. The gas bubbles can exit chamber 653 through port 654 with air venting filter 656, which allows for the release of gas and not liquid. Additionally, the fluid in the balloon can be agitated to prevent freezing. This may be accomplished by moving cold probe 657 or pulsing the infusion of the cooling agent into chamber 653. Additionally, a second assembly can also be inserted into the other nostril such that maximum cooling can be obtained. The cooling of the brain would occur by convection or heat exchange from the cold liquid in the balloon to the warm nasal cavity.

[0201] Flexible balloons for use in the nasal cavity are sized such that upon inflation, they are capable of making good contact with the surfaces of the nasal cavity, including the portion of the cavity that lies posterior to the cavernous sinus. In one embodiment, the length of the flexible balloon will depend upon the size of the nasal cavity and may be less than 15 cm long, alternatively less than 14 cm long, alternatively less than 13 cm long, alternatively less than 12 cm long, alternatively less than 11 cm long, alternatively less than 10 cm long, alternatively less than 9 cm long, alternatively less than 8 cm long. The flexible balloons may also have the shape of the nasal cavity. Alternatively, as seen in FIG. 30, flexible balloon 750 may have a shape containing multiple fingers such that, upon inflation, one or more fingers will have the opportunity to extend into and fill the meatus (superior,

middle, and/or inferior) to maximize contact with the tissues in the nasal cavity. Alternatively, the flexible balloon may have multiple lobes to accomplish the same purpose of extending into and filling the meatus. The flexible balloons are also preferably oversized and made of a soft, conformable, elastomeric material to provide maximum surface contact with the nasal cavity. The assemblies may also include a check valve (not shown) that will release fluid, thereby reducing the pressure of the flexible balloons when they reach a certain pressure. Optionally, the flexible balloons may be made of a porous material that allows for the controlled release of drugs to the nasal cavity. Examples of materials for the elastomeric, flexible balloons include, but are not limited to, urethanes, vinyl (PVC), silicone. Examples of non-elastic materials include, but are not limited to, mylar, polyethylene, polypropylene, polystyrene, and polyvinylacetate.

[0202] In use, the pressure in these flexible balloons for use in the nasal cavity can oscillate between lower and higher pressures. In other words, the fluid can be infused to fill the chamber defined by the balloon either slowly or quickly. When expanded at higher pressures, presumably more heat transfer will occur due to increased contact with the nasal cavity. Extended periods at higher pressures, however, may not be desirable due to possible problems with stopping blood flow in the surrounding tissue. Additionally, the act of pulsing the liquid would result in increased circulation of the liquid. Rapid pulsing, for the purposes of mixing the liquid within the balloon chamber, could range from about 0.5 to about 200 Hz, alternatively from about 1 to about 150 Hz, alternatively from about 1 to about 100 Hz, alternatively from about 10 to about 100 Hz, alternatively from about 25 to about 100 Hz. Slower pulsing could be used to effect physiologic responses, such as deflating the balloon to allow blood flow to resume circulation in the cooled area. Slower pulsing could range from about one inflation per second to about one inflation per 10 minutes, alternatively from about one inflation per second to about one inflation per 5 minutes, alternatively from about one inflation per second to about one inflation per 3 minutes. Alternatively, the balloon could be inflated approximately once every 30 seconds, alternatively once every 1 minute, alternatively once every 2 minutes, alternatively once every 3 minutes, alternatively once every 4 minutes, alternatively once every 5 minutes, alternatively once every 6 minutes, alternatively once every 7 minutes, alternatively once every 8 minutes, alternatively once every 9 minutes, alternatively once every 10 minutes. During these slower cycling periods, the balloon could remain inflated for approximately 1% of the cycling period, alternatively approximately 5% of the cycling period, alternatively approximately 10% of the cycling period, alternatively approximately 20% of the cycling period, alternatively approximately 30% of the cycling period, alternatively approximately 40% of the cycling period, alternatively approximately 50% of the cycling period.

Cooling Calculations

[0203] The following calculations estimate the maximum cooling that can be obtained when a chilled liquid is circulated through the nasal cavity, where the chilled fluid is either directly in contact with the nasal tissues or contained in a flexible membrane 'balloon' within the nose.

[0204] A cooling liquid is circulated into and out of the nasal cavity. The following calculations are done assuming that the chilled fluid will be an aqueous fluid. The following are properties of water:

[0205] Density: 1 gram/ml

[0206] Heat capacity: 1 cal/gram-° C.

[0207] The liquid will enter the nasal cavity at a temperature well below body temperature, and exit at a warmer temperature. The warming of the water will be equal to the cooling of the body, so the calculations for heat added to the water is the same as that for heat removed from the body.

$$Q' = c * m * (T_2 - T_1) \text{ or } Q' = cm\Delta T \quad \text{Equation 1}$$

[0208] Q'=the rate of heat transfer

[0209] m=the mass flow rate of the liquid administered

[0210] c=the heat capacity of the liquid

[0211] T1=the temperature of the liquid at administration

[0212] T2=the temperature to which the liquid is warmed

[0213] If the flow rate is 500 ml/min, inlet temperature is 2° C., outlet temperature is 4° C.

$$\text{Heat Transfer} = 500 \text{ ml/min} * 1 \text{ g/ml} * 1 \text{ cal/gm} \text{ } ^\circ \text{C.} * (4^\circ \text{C.} - 2^\circ \text{C.}) = 1000 \text{ cal/min}$$

[0214] Conversion factors: 1 calorie/minute=0.069 78 watt

[0215] 1000 cal/min*0.06978 Watt/cal/min=70 Watts

[0216] The cooling of the whole body can be calculated using the same equation as above. The heat capacity of the human body is generally accepted to be 0.85 cal/gm ° C. For this calculation, other sources of heat entering or leaving the body, and heat generated in the body are neglected, as it is likely those aspects balance out in a stable patient. Cooling therefore reduces to the equation below.

$$\text{Whole body cooling } (\Delta T) = \text{Heat removed} / (\text{mass} * \text{heat capacity})$$

[0217] Continuing the example above, for a 75 kg patient, the temperature change is calculated below to be 0.93° C. per hour, which is close to the target cooling rate for patients.

$$\begin{aligned} \text{Temperature change} &= \frac{1000 \text{ cal/min}}{(75,000 \text{ grams} * 0.85 \text{ cal/gram } ^\circ \text{C.})} \\ &= 0.0157 \text{ } ^\circ \text{C./min} \\ &= 0.93 \text{ } ^\circ \text{C. per hour} \end{aligned}$$

[0218] For whole body cooling (WBC), the following formula can be developed from the above:

$$\text{WBC } (^\circ \text{C./hr}) = \Delta T(\text{liquid, } ^\circ \text{C.}) * \text{Flow rate (ml/min)} / (\text{Patient wt(kg)} * 14.3)$$

or

$$\text{WBC } (^\circ \text{C./hr}) = \text{Cooling (watts)} / \text{Patient Weight (kg)}$$

[0219] The surface of the balloon may be treated or modified to maximize thermal conductance. A gel may also be optionally applied to the exterior of flexible balloons 204, 254 before insertion into the nasal cavity. The gel would preferably have good thermal conduction properties and be a better conductor than air. Additionally, the gel could also act as a lubricant to assist in the insertion. The gel may include, but is not limited to, any aqueous gel, a poloxamer-based gel, a

cellulose gel (such as KY jelly), a nasal-packing jelly, or a thermal gel. Alternatively, sponges may be attached to the surface of the balloon. Sponges, such as PVA sponges, are commonly used as packing material in noses and will conform to the shapes of the nasal cavity when wet. Alternatively, a hydrophilic coating may also be applied to the outer surface of the balloon to prevent beading on the outside.

[0220] Advantages of this apparatus and method include rapid circulation of the cooling fluid, rapid transfer of heat from the flexible balloon to the membranes of the nasal cavity, and flexibility in choice of coolant because the fluid is contained. Heat is transferred through the mucosa from the pool of blood in the cavernous sinus to the cooling fluid in the flexible balloon, thereby cooling the pool of blood in the cavernous sinus. Consequently, the blood in the carotid arteries, which runs through the cavernous sinus, is also cooled as it travels to the brain. In particular, the maximal heat exchange will likely be with the ascending carotid arteries immediately before entry into the intracranial space and the terminal portion of the extracranial internal carotid artery.

[0221] In another aspect of the invention, as seen in FIG. 49, thermoconducting gel 850 may be inserted into the nasal cavity of a patient to substantially fill the cavity. Cooling device 852, such as a cold probe or heat pipe, can then be directly inserted into gel 852 to cool gel 852, thereby cooling the nasal cavity. The conductive device could be a metal, such as copper. Alternatively, conductive device 852 may be a probe through which a chilled fluid is circulated, a probe in which a fluid undergoes a phase change, or a heat pipe, which is a sealed system utilizing an internal fluid that boils on one end and condenses on the other end in order to transmit heat. In the case of the probe with the fluid undergoing a phase change, the fluid may have a boiling point below body temperature, such as a perfluorocarbon or Freon. Additionally, external cooling source 854, such as a refrigeration system, thermoelectric heat pump, ice bath, or evaporative cooler, will be connected to the proximal end of the probe. Consequently, a cerebral temperature of the patient can be reduced by at least 1° C. in one hour, alternatively at least 2° C. in one hour, at least 3° C. in one hour.

[0222] In another aspect of the invention, a sponge may be inserted into the nasal cavity of a patient to substantially fill the cavity. As mentioned previously, the sponge could surround the outside of a balloon to help fill the nasal cavity. The sponges may help to fill the back of the mouth and come into intimate contact with the soft palate and upper pharynx. Alternatively, the sponge could be inserted into the nasal cavity alone. The sponge could be connected to an inlet and outlet tubular member to allow for circulation of fluids within the sponge. In contrast to the balloon, the increased surface area of the sponge would allow for better contact with the interior surfaces of the nasal cavity. Additionally, the sponges could be designed with finger or hair-like extrusions to increase the surface area, thereby increasing contact with the interior surfaces of the nasal cavity. A hollow tube could be inserted through the sponge and/or balloon to facilitate breathing.

Convective Cooling in Other Parts of the Body

[0223] In another aspect of this invention, a modified nasogastric tube with a flexible balloon having a chamber filled with a cooling liquid may be used to cool the brain. As seen in FIG. 24, the assembly includes nasogastric tube 356 having lumen 357, flexible balloon 354 that is mounted circumferentially around nasogastric tube 356 for the length of the

esophagus, and elongate tubular member **360** having lumen **362**. Nasogastric tube **356** is approximately 0.8 m in length, alternatively approximately 1 m in length, alternatively approximately 1.2 m in length, alternatively approximately 1.4 m in length, alternatively approximately 1.6 m in length, alternatively approximately 1.8 m in length, alternatively between about 0.8 m and 1.8 m in length. An additional flexible balloon **358** may be attached at the distal end of the nasogastric tube **356**. Flexible balloon **358** would be in fluid communication with lumen **357** of nasogastric tube **356** and a chamber of flexible balloon **354** and, upon expansion, would be sized to substantially fill the patient's stomach. Alternatively, at its distal end, flexible balloon **354** may be sized and shaped to substantially fill the patient's stomach upon expansion. At their proximal ends, elongate tubular member **360** and nasogastric tube **356** are connected to a pump and a cooler (not shown) or a refrigerated pump (not shown) that is capable of infusing and/or recycling a cooling fluid through flexible balloons **354**, **358**. Flexible balloons **354**, **358** are sized that upon inflation, they are capable of making good contact with the surfaces of the adjacent anatomy, e.g., nasal cavity, esophagus, or stomach. Flexible balloons **354**, **358** are also preferably oversized and made of a soft, conformable, elastomeric material to provide maximum surface contact with the anatomy in which they are positioned. Flexible balloons **354**, **358** may also include a check valve (not shown) that will release fluid, thereby reducing pressure of flexible balloons **354**, **358** when they reach a certain pressure. Optionally, all or a portion of flexible balloons **354**, **358** may be made of a porous material that allows for the controlled release of drugs.

[0224] In use, the patient is intubated and the assembly is inserted through a patient's nostril, down the back of the throat, through the esophagus, and into the stomach. The assembly is positioned such that flexible balloon **354** is located in the nasal cavity and the esophagus and flexible balloon **358** is located in the stomach. A cooling fluid can then be infused into flexible balloons **354**, **358** to expand the balloons such that they substantially fill and contact the nasal cavity, esophagus, and stomach, respectively. The cooling fluid could be pumped in through nasogastric tube **354** and suctioned out of elongate tubular member **360** at a rate sufficient to induce or maintain a desired pressure in the flexible balloons **354**, **358** or a desired brain temperature. The cooling fluid may then be recirculated through flexible balloons **354**, **358** via nasogastric tube **356**, shaft **360**, and a refrigerated pump (not shown).

[0225] In another aspect of this invention, a modified laryngeal mask having a flexible balloon having a chamber filled with a cooling liquid can be used to cool the brain. As seen in FIG. 25A, the laryngeal mask **320** includes an elongate tubular member **322** having a proximal end, a distal end, and a lumen **323** therebetween that communicates with ports at the proximal and distal ends. The elongate tubular member **322** is preferably curved to match the anatomy of the oropharynx. Toroidal balloon **324** has a chamber, and surrounds port **325** at the distal end of elongate tubular member **322**, wherein the chamber is in fluid communication with lumens **326**, **328** of elongate tubular members **327**, **329**. Alternatively, lumens **326**, **328** may be part of elongate tubular member **322**. Elongate tubular members **327**, **329** are also connected to a pump and cooling unit (not shown) or a refrigerated pump (not shown) that is capable of infusing and/or recycling a cooling fluid through flexible toroidal balloon **324**. The cooling fluid may include, but is not limited to, water, saline, PFC, anti-

freeze solution, or a combination thereof. As seen in FIG. 25B, the modified laryngeal mask may also include an additional balloon **330** that is located on the distal region of the backside of elongate tubular member **322**, wherein a chamber of additional balloon **330** is in fluid communication with lumens **332**, **334**. Lumens **332**, **334** may be part of elongate tubular member **322** or part of separate elongate tubular members. Additionally, the chamber of additional balloon **330** may alternatively be in fluid communication with lumens **326**, **328** (not shown). Lumens **332**, **334** would also be connected to a pump and cooling unit (not shown) or a refrigerated pump (not shown) that is capable of recycling the cooling fluid through flexible balloon **330**.

[0226] In use, as seen in FIG. 25C, the modified laryngeal mask **320** is positioned in the patient to sit tightly over the larynx. Toroidal balloon **324** is emptied before insertion and lubricated with a gel. In addition to being a good lubricant, the gel would also preferably have good thermal conduction properties and be a better conductor than air. The gel may include, but is not limited to, a poloxomer-based gel (such as KY jelly) or a packing jelly. The neck of the patient is extended and the mouth is opened widely. The apex of the laryngeal mask **320**, with the port or opening **325** pointing downwards toward the tongue, is pushed backwards toward the uvula. Elongate tubular member **322** follows the natural bend of the oropharynx and the mask comes to rest over the piriform fossa. A cooling fluid can then be used to infuse and/or inflate toroidal balloon **324** to a sufficient pressure such that toroidal balloon **324** sits tightly over the larynx and is in contact with the epiglottis. The cooling fluid may then be recirculated through toroidal balloon **324** via lumens **326**, **328**, cooler (not shown), and pump (not shown). Additionally, the cooling fluid can be withdrawn or suctioned out of toroidal balloon **324** at a rate sufficient to induce or maintain a desired balloon pressure or brain temperature. During the cooling process, the airway is protected by the elongate tubular member **322**.

[0227] In another aspect of this invention, a cooling pad may be used to cool the brain via the oral cavity. As seen in FIG. 26, the assembly **400** includes a flexible balloon or pad **402** having a chamber, tubular members **403**, **405** having lumens **404**, **406** and ports **405**, **407**, wherein the chamber is in fluid communication with port **405**, **407** and lumen **404**, **406**. At their proximal ends, tubular members **403**, **405** are connected to cooler **410** and pump **412**. Alternatively, tubular members **403**, **405** may be connected to a refrigerated pump (not shown) that is capable of infusing and/or recirculating cooling fluid. The pad may be about 2.5 cm in length, alternatively about 3 cm in length, alternatively about 3.5 cm in length.

[0228] In use, the assembly **400** is inserted into the oral cavity through the mouth such that the flexible balloon or pad **402** covers the retromandibular area or peritonsillar region. A cooling fluid can then be infused into the chamber of flexible balloon or pad **402** to expand it to a sufficient pressure such that flexible balloon or pad **402** is substantially in contact with the retromandibular area or peritonsillar region. The cooling fluid may then be recirculated through flexible balloon **402** via lumens **404**, **406**, using pump **412** and cooler **410** or a refrigerated pump. The cooling fluid can also be withdrawn or suctioned out of the flexible balloon **402** at a rate sufficient to induce or maintain a desired balloon pressure or brain temperature. Cooling of the brain may be achieved through con-

vection or heat transfer between flexible balloon or pad **402** and the extracranial carotid artery.

[0229] The cooling fluid used with these inventions may include, but is not limited to, water, saline, PFC, anti-freeze solution, or a combination thereof. The temperature of the cooling fluid will preferably be below body temperature. The temperature of the cooling fluid may be between about 37° C. to about -20° C., alternatively between about 30° C. to about -20° C., alternatively between about 20° C. to about -20° C., alternatively about 0° C., alternatively about 5° C., alternatively about -5° C., alternatively between about -5° C. to about 10° C., alternatively between about -5° C. to about 5° C., alternatively between about 0° C. to about 5° C. When saline is used as the cooling fluid, the saline will preferably be about 0° C. The cooling fluid should recirculate at a fast enough rate to maintain the low temperatures within the balloon. The flow rate of the cooling liquid may be between about 5 and about 5 L/min, alternatively between about 100 and about 400 ml/min, alternatively between about 200 and about 300 ml/min, alternatively between about 150 to about 200 ml/min.

[0230] Optionally, a gel may also be optionally applied to the exterior of flexible balloons before insertion into the oral cavity. The gel would preferably have good thermal conduction properties and be a better conductor than air. Additionally, the gel could also act as a lubricant to assist in the insertion. The gel may include, but is not limited to, any aqueous gel, a poloxamer-based gel, a cellulose gel (such as KY jelly), a nasal-packing jelly, or a thermal gel. Alternatively, sponges may be attached to the surface of the balloon. Sponges, such as PVA sponges, are commonly used as packing material and will conform to the shapes of the oral cavity when wet. The sponges could be designed with finger or hair-like extrusions to increase the surface area, thereby increasing contact with the interior surfaces of the oral cavity. The sponges may fill the back of the mouth and allow for maximal cooling at the soft palate and retropharynx. Alternatively, a hydrophilic coating may also be applied to the outer surface of the balloon to prevent beading on the outside. A tube may also be inserted to allow breathing.

Fluid/Gas Delivery Systems

[0231] In another embodiment, the invention includes a liquid and gas delivery system for the delivery of a fixed, or substantially fixed, ratio of liquid and gas. As seen in FIG. 31, in delivery system **500**, gas flow meter **505** can be set to deliver a set flow of gas to mixing hub or manifold **510** through gas line **507**. As gas is delivered to manifold **510**, gas will also flow to bottle **520** through gas line **508**. Gas lines **507** and **508** may also comprise a single branched tube (not shown). As reservoir or bottle **520** becomes pressurized, liquid **525** in bottle **520** will flow through line **530** to manifold **510**. The flow of the liquid will directly depend on the pressure of the gas being delivered from flow meter **505**—i.e., higher gas pressure will result in a faster flow of liquid. Therefore, a fixed ratio of liquid and gas can be delivered to the manifold. As the flow rate of the gas is increased, a proportional increase in the liquid flow rate occurs, such that the ratio of liquid to gas being delivered to mixing manifold **510** is maintained without having to independently adjust the flow of the liquid. Flow restrictors **535** and **536** can be set to each allow a specific flow of liquid for a specific pressure of gas. For example, flow restrictor **535** may allow a higher flow rate than flow restrictor **536** for a specific pressure of gas.

Stopcock **532** can be connected to line **530**. Stopcock **532** is used to direct flow either to restrictor **535** or **536** or can be used to stop liquid flow altogether. Filter **537** can also be placed in line **530** before mixing manifold **510**. An overpressure safety device **515** within gas flow meter **505** can stop the flow of gas if a certain pressure is detected. Activation of the overpressure safety device **515** would switch valve **570** to stop gas flow and vent gas lines **507** and **508**. Therefore, the pressure in gas lines **507** and **508** and bottle **520** will all be reduced to zero. Therefore, the flow of liquid will also be stopped by the activation of safety device **515**. The gas could be air, oxygen, or a combination thereof. The liquid could include a perfluorocarbon such as perfluorohexane, perfluoropentane, or 2-methyl-perfluoropentane.

[0232] Mixing manifold **510** can be connected to catheters **540** and **545**, each containing multiple delivery ports **541** and **546** for delivery of the gas and liquid mixture to, for instance, the nasal cavity. Liquid can flow from line **530** into liquid lumens **572** and **574** of catheters **540** and **545** through ports **560** and **562**, respectively. Similarly, gas can flow from line **507** into lumens **542** and **547** of catheters **540** and **545** through ports in the distal ends of the respective catheters. The gas and liquid can later be mixed and delivered to the nasal cavity through the multiple ports **541** and **546** as a nebulized spray, as described above. Pressure in the nasal cavity can be measured through pressure lines **511** and **512**, which are in communication with ports **565** and **566** located near the distal ends of catheters **540** and **545** through pressure lumens **576** and **578** and ports **561** and **563**, respectively. Alternatively, a separate catheter could be inserted to measure the pressure in the nasal cavity (not shown). If a pressure measured in the nasal cavity in which the liquid and gas is being delivered is found to be too high, overpressure safety device **515** will stop the flow of gas, and consequently, the flow of liquid, to the nasal cavity. Additionally, the stopcock could be closed when it is desired to only deliver a gas, for instance, oxygen, rather than cool the patient.

[0233] An alternative embodiment of the liquid and gas delivery system is depicted in FIG. 45. The mixing catheter may further include a liquid delivery system for using the pressure from the compressed gas source to deliver the liquid to the nasal catheter. In this device, both the gas and the liquid are delivered strictly using the pressure from the compressed gas source without the use of pumps or electronics. Here, inlet valve **964** is connected to compressed gas source **960**, for example, oxygen or an oxygen and air mixture regulated to about 50 psi. Inlet valve **964** blocks or allows the pressurized gas into the rest of the system. When inlet valve **964** is in the “blocked” position, valve **964** also may vent pressure from the system. Pressure regulator **962** may also allow better control of the gas pressure delivered to the liquid delivery system and to the nasal catheter. When the inlet valve is in the “allow” position, the gas flow splits in two directions, i.e., flow is connected to the gas flow channel **978** of the dual lumen tubing (not shown) and flow is also directed to fluid reservoir container **968** that is designed to hold the desired dose of a liquid.

[0234] The fluid control reservoir **968** is rated to withstand the pressure of the compressed gas, for example the fluid control reservoir may be a poly ethylene terephthalate (PET) container tested to pressures in excess of 150 psi. In addition, a burst disk or relief valve **966**, set at a value exceeding the expected operating pressure, for example 60 psi, alternatively 70 psi, alternatively 80 psi, alternatively 90 psi, may be added

to the fluid reservoir container as a safety means for venting gas in the event of over pressurization. When the pressurized gas flows into fluid reservoir **968**, the fluid is routed through an outlet port in the reservoir that is in fluid communication with liquid channel **980** of the dual lumen tubing (not shown). The outlet port may include fluid flow controlling device **972**, such as a needle type valve or a variable diameter aperture, to adjust the flow rate of fluid into liquid channel **980** of the dual lumen tubing. In addition, gas flow channel **978** of the dual lumen tubing may also include flow controlling device **970**, such as a needle type valve or a variable diameter aperture, to adjust the flow rate of gas into the gas channel of the dual lumen tubing. The flow control valves **970** and **972** of the gas and liquid channels may be independently controlled by the operator to allow full flexibility in varying the gas and/or liquid flow to optimize the gas/liquid flow ratio. The gas and liquid flow control valves **970** and **972** may have fixed orifices that produce a known constant flow for the gas and the liquid, or alternatively, the flow control valves **970** and **972** may include a selector (not shown) that would allow the operator to choose one of several sets of orifices in order to provide the operator with a number of choices for the flow, for example low flow, medium flow, high flow, induction, and maintenance flow rates. Here, each set point on the selector would use a predetermined orifice for the gas flow and a matched orifice for the liquid such that the gas/liquid flow rates and ratios would be optimized for each condition. In an alternative embodiment, the flow rate generated by the fixed orifices may be further altered while maintaining the constant gas/liquid ratio, by using pressure regulator to regulate the input pressure of the gas source. In addition, liquid and gas flow meters **974** and **976** may be placed in the liquid and gas flow channels to further monitor and regulate the liquid and gas flow rates. Flow meters **974** and **976** may be any standard flow technology such as turbines, paddlewheels, variable area Rota meters or mass flow meters. In addition, in-line filters (not shown) may be placed in both the gas and liquid channels to prevent particulate matter from being introduced to the patient.

[0235] Although the foregoing invention has, for the purposes of clarity and understanding, been described in some detail by way of illustration and example, it will be obvious that certain changes and modifications may be practiced which will still fall within the scope of the appended claims.

1. A method for cerebral cooling, comprising the steps of inserting a cooling assembly into a nasal cavity of a patient through a patient's nostril; delivering a spray having a boiling point of between 38-300° C. onto the surface of the patient's nasal cavity through the cooling assembly; monitoring a physiological parameter; adjusting the delivery of the spray through the cooling assembly in response to the physiological parameter.
2. The method of claim 1, wherein the step of monitoring a physiological parameter comprises measuring the patient's temperature, and wherein the step of adjusting delivery of the spray comprises adjusting the delivery of the spray in response to the patient's temperature.
3. The method of claim 2, wherein the step of measuring the patient's temperature comprises measuring one of the patient's cerebral temperature, nose temperature, tympanic temperature, body temperature or rectal temperature.
4. The method of claim 3, wherein the step of measuring the patient's temperature further comprises continuously monitoring the patient's temperature.

5. The method of claim 3, wherein adjusting the delivery of the cooled liquid further comprises using the patient's temperature to stop and/or start delivery of the spray.

6. The method of claim 3, wherein adjusting the delivery of the spray further comprises using the patient's temperature to adjust the rate of delivery of the spray.

7. The method of claim 3, wherein the step of measuring the patient's temperature comprises measuring the patient's cerebral temperature.

8. The method of claim 7, further comprising the step of setting a target temperature for the cerebral temperature, wherein the step of delivering of the spray further comprises delivering a spray onto the surface of the patient's nasal cavity until the cerebral temperature reaches the target temperature.

9. The method of claim 8, further comprising automatically stopping delivery of the spray when the patient's cerebral temperature reaches the target temperature.

10. The method of claim 8, further comprising automatically restarting delivery of the spray when the patient's cerebral temperature rises more than 0.5° C. above the target temperature.

11. The method of claim 8, wherein the target temperature is set by an operator within a range of about 30-37° C.

12. The method of claim 8, wherein the step of adjusting the delivery of the spray further comprises restarting delivery of the spray when the patient's cerebral temperature reaches substantially greater than the target temperature.

13. (canceled)

14. (canceled)

15. (canceled)

16. (canceled)

17. The method of claim 1, wherein the step of monitoring a physiological parameter comprises monitoring the patient's cerebral blood flow, and wherein the step of adjusting delivery of the spray comprises adjusting the delivery of the spray in response to changes in the patient's cerebral blood flow.

18. The method of claim 1, wherein the step of monitoring a physiological parameter comprises monitoring the patient's brain oxygenation, and wherein the step of adjusting delivery of the spray comprises adjusting the delivery of the spray in response to changes in the patient's brain oxygenation.

19. The method of claim 1, wherein delivering a spray further comprises delivering a perfluorocarbon spray and a gas onto a surface of the patient's nasal cavity, wherein the gas enhances evaporation of the perfluorocarbon from the nasal cavity.

20. The method of claim 19, wherein the gas is oxygen.

21. The method of claim 19, wherein the perfluorocarbon has a boiling point above 37° C.

22. (canceled)

23. (canceled)

24. (canceled)

25. A method for cerebral cooling, comprising the steps of: inserting a cooling assembly into a nasal cavity of a patient through a patient's nostril; delivering a cooled liquid having a temperature of between -20° C. and 37° C. to the patient's nasal cavity through the cooling assembly;

measuring a physiological parameter;
adjusting the delivery of the cooled liquid through the cooling assembly in response to the physiological parameter.

26-43. (canceled)

44. The method of claim 1, wherein the cooling assembly comprises:

an elongate comprising a proximal end, a distal end, a first lumen extending therebetween, and a plurality of ports in fluid communication with the first lumen; and wherein the step of delivering a spray further comprises delivering a perfluorocarbon spray and a gas onto a surface of the patient's nasal cavity through the plurality of ports in the elongate member.

* * * * *