

No. 689,707.

Patented Dec. 24, 1901.

H. A. DAVIS.
DRAWING TABLE.

(Application filed Jan. 23, 1901.)

(No Model.)

2 Sheets—Sheet 1.

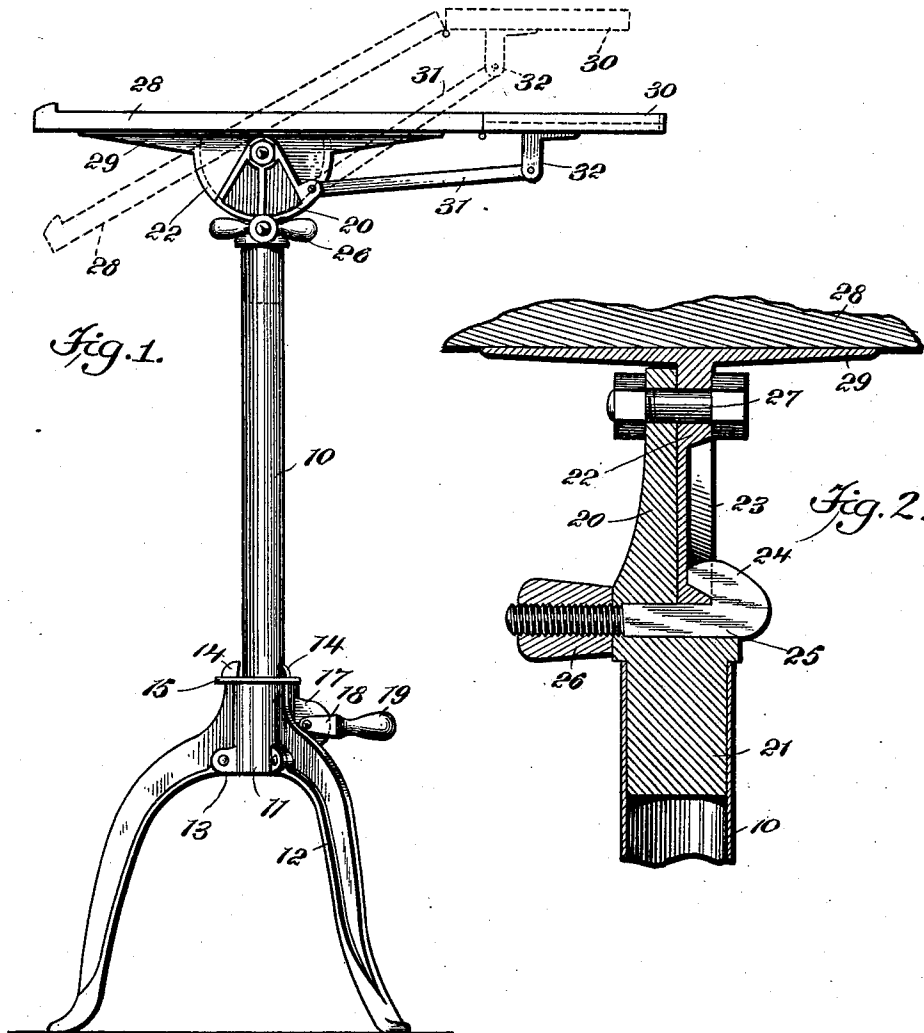

WITNESSES:

A. Appleman
C. R. Ferguson

INVENTOR

Henry A. Davis

BY *Neuman*
ATTORNEYS

No. 689,707.

Patented Dec. 24, 1901.

H. A. DAVIS.
DRAWING TABLE.

(Application filed Jan. 23, 1901.)

(No Model.)

2 Sheets—Sheet 2.

Fig. 3.

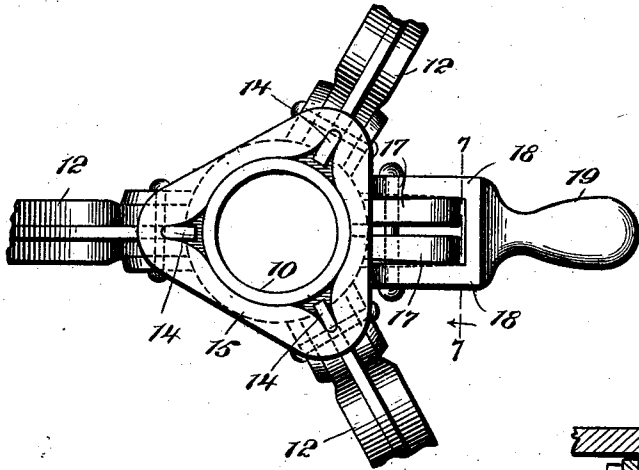

Fig. 8.

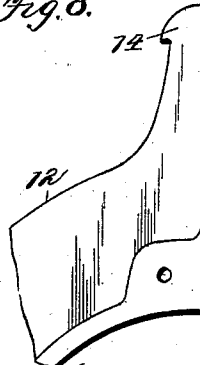

Fig. 5.

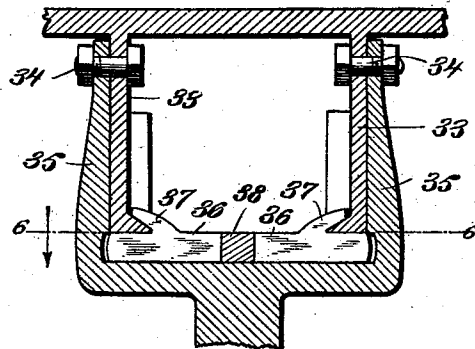

Fig. 4.

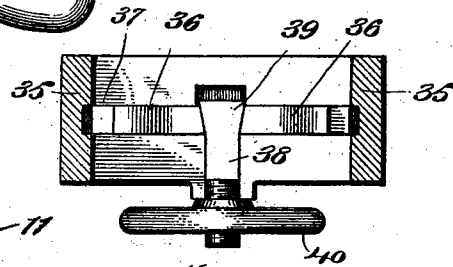
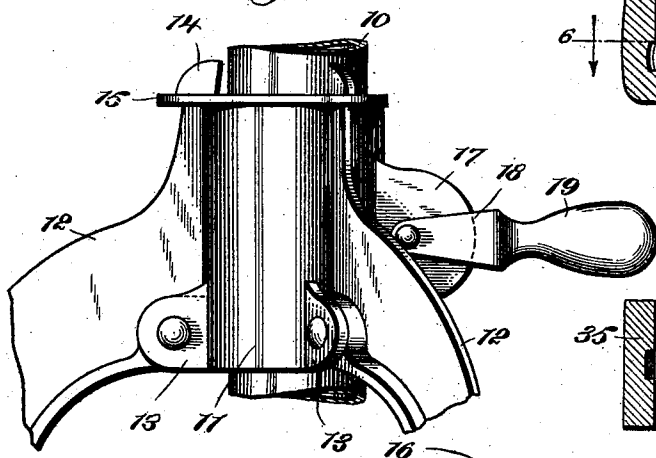

Fig. 6.

WITNESSES:

A. R. Appleman
C. R. Tringwood

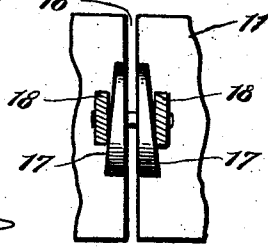

Fig. 7.

INVENTOR
Henry A. Davis
BY *Munn*
ATTORNEYS

UNITED STATES PATENT OFFICE.

HENRY AMON DAVIS, OF MUSKEGON, MICHIGAN.

DRAWING-TABLE.

SPECIFICATION forming part of Letters Patent No. 689,707, dated December 24, 1901.

Application filed January 23, 1901. Serial No. 44,449. (No model.)

To all whom it may concern:

Be it known that I, HENRY AMON DAVIS, a citizen of the United States, and a resident of Muskegon, in the county of Muskegon and State of Michigan, have invented a new and Improved Drawing-Table, of which the following is a full, clear, and exact description.

This invention relates to improvements in drawing-tables; and the object is to provide a table of very simple construction and particularly cheap to manufacture, that may be quickly and easily adjusted as to height and pitch or incline, and that when not in use may be folded in compact form.

I will describe a drawing-table embodying my invention and then point out the novel features in the appended claims.

Reference is to be had to the accompanying drawings, forming a part of this specification, in which similar characters of reference indicate corresponding parts in all the figures.

Figure 1 is a side elevation of a table embodying my invention. Fig. 2 is a sectional view showing an adjusting device employed. Fig. 3 is a plan view of the base. Fig. 4 is a side view thereof. Fig. 5 is a section showing a modified form of adjusting device. Fig. 6 is a section on the line 6 6 of Fig. 5. Fig. 7 is a section on the line 7 7 of Fig. 3, and Fig. 8 is a detail showing the upper portion of one of the legs.

Referring to the drawings, 10 designates a standard which for the sake of lightness and strength will be made of tubular metal. This standard is adjustable vertically in a base, comprising a sleeve 11, open longitudinally at one side, so that it may be clamped upon the standard, and supported by legs 12. These legs 12 are pivotally connected to lugs 13, extended outward from the lower end of the sleeve, and at their upper ends the legs are provided with hook portions 14, designed to be engaged by a holding-ring 15. There will be sufficient play between the upwardly-projected portions of the legs and the sleeve 11 to permit said upper portions to be moved inward to pass through the holding-ring, so as to prevent an accidental upward movement of said ring, as it is to be understood that the ring is to hold the legs in their extended position should the table be lifted

for movement from place to place. Upon removing this ring, with its connections with the legs, the legs may be swung inward or toward each other, so as to take up but very little room in packing for the transportation of the device.

Extended outward from the opposite sides of the opening 16 of the sleeve are lugs 17, and pivoted to these lugs are clamping-arms 18, which are connected at the outer end by a handle 19. The pivot for the arms will be loosely extended through the lugs 17, and the outer surfaces of these lugs are inclined downward and outward, while the inner surfaces of the arms 18 are correspondingly shaped. Therefore when it is desired to clamp the sleeve upon the standard 10 it is only necessary to force the arms 18 downward, which will draw the sleeve closely against the standard, and it is obvious that by a reverse movement of the arms the standard will be released, so that it may be adjusted.

On the upper end of the standard 10 is a head 20, of cast metal. This head may be securely fastened to the standard 10 by shrinking said standard upon the stem portion 21 of the head. Pivotaly connected to the head 20 is a clamping-plate 22. This clamping-plate is provided with an outwardly-extended segmental flange 23, designed to be engaged by the hook portion 24 of a clamping-bolt 25, movable through an opening in the head 20, and on the screw-threaded portion of this bolt is a thumb or set nut 26. The plate 22 is pivoted to the head 20 by means of a bolt 27, and obviously the said plate may be rotated or turned on this bolt to secure any desired angle of the table-top 28, which is secured to said plate. After the adjustment by tightening the nut 26 the hook portion 24 of the bolt will be drawn tightly into engagement with the flange 23. The table-top 28 is secured by screws or otherwise which pass through a top plate 29 on said plate 22.

Hinged to one edge of the table-top 28 is a platform 30 for ink-bottles, drawing materials, and the like. This platform is designed to maintain a horizontal position, while the table-top is placed at any desired angle. To cause the said platform to maintain its horizontal position, I provide a link connection 31 between

the head 20 and a lug 32, extended downward from the platform, this link of course being pivoted to the head and to said lug.

In the example of my invention shown in Figs 1 and 2 I provide but one clamping-plate, while in the example shown in Figs 5 and 6 there are two segmental clamping-plates 33, which are pivoted by bolts 34 to a head comprising upright members 35. Two clamping-bolts 36 are movable on the base of the head and have hook portions 37 for engaging over the flanges of the clamping-plates. These bolts are moved outward by means of an adjusting-bolt 38, having divergent sides at its inner end 39, which engage with the beveled inner ends of said bolts, and on the outer end of this bolt 38 is an adjusting nut or wheel 40.

Having thus described my invention, I claim as new and desire to secure by Letters Patent—

1. A drawing-table, comprising a standard, a head on said standard, a table-top, a segmental plate attached to said top and having a curved flange on one side, and a clamping-bolt movable relatively to the head and having members for engaging the opposite sides of said flange, substantially as specified.
2. A drawing-table, comprising a standard,

a head on said standard, a table-top, a segmental plate attached to said top and having a flange at one side, and a clamping-bolt movable relatively to the head and having a hook portion to engage with said flange, substantially as specified.

3. In a drawing-table, a standard, a head on said standard, a table-top, a plate attached to said table-top and having pivotal connection with the head, a segmental flange extended outward from one side of said plate, and a locking-bolt movable through the head and having a hook portion to engage over said flange, substantially as specified.

4. In a table, a standard, a sleeve engaging around said standard, legs pivoted to said sleeve and having hook portions at the upper ends, and a ring for engaging around said upper ends below the hook portions, substantially as specified.

In testimony whereof I have signed my name to this specification in the presence of two subscribing witnesses.

HENRY AMON DAVIS.

Witnesses:

RUFUS L. PARK,
FRANK NELSON CAREY.