



US00RE38678E

(19) **United States**  
(12) **Reissued Patent**  
**Olafsson**

(10) **Patent Number: US RE38,678 E**  
(45) **Date of Reissued Patent: Dec. 28, 2004**

(54) **METHOD AND APPARATUS FOR SYNCHRONIZING A DATA COMMUNICATIONS SYSTEM TO A PERIODIC DIGITAL IMPAIRMENT**

(75) Inventor: **Sverrir Olafsson, Reykjavik (IS)**  
(73) Assignee: **Conexant Systems, Inc., Newport Beach, CA (US)**

(21) Appl. No.: **09/849,500**  
(22) Filed: **May 4, 2001**

**Related U.S. Patent Documents**

Reissue of:  
(64) Patent No.: **6,023,493**  
Issued: **Feb. 8, 2000**  
Appl. No.: **09/009,228**  
Filed: **Jan. 20, 1998**

(51) **Int. Cl.<sup>7</sup>** ..... **H04L 7/00**  
(52) **U.S. Cl.** ..... **375/354; 370/507; 370/523**  
(58) **Field of Search** ..... **375/222, 354, 375/364, 365, 356, 219, 220, 221, 377; 370/503, 505, 504, 520, 509, 508, 507, 523**

(56) **References Cited**

**U.S. PATENT DOCUMENTS**

4,730,312	A	*	3/1988	Johnson et al.	.....	370/523
5,048,054	A	*	9/1991	Eyuboglu et al.	.....	375/222
5,349,579	A		9/1994	Madonna et al.		
5,398,234	A	*	3/1995	O'Connell et al.	.....	370/249
5,509,036	A	*	4/1996	Nakata	.....	375/368
5,535,244	A	*	7/1996	Nakatsu et al.	.....	375/261

(List continued on next page.)

**FOREIGN PATENT DOCUMENTS**

JP	9107419		4/1997	
WO	9808327		2/1998	
WO	WO 98/08327	*	2/1998	
WO	9817044		4/1998	
WO	WO 98/17044	*	4/1998	

**OTHER PUBLICATIONS**

Dale Walsh, Apr. 9, 1997, TIA Committee Contribution, analyzing code translation characteristics of a PCM channel and communicating a mutual PCM code signaling set.\*  
Dewent abstract XP-0022105165, Jan. 11, 1998. International search report for PCT/US99/01005 Aug. 3, 1999.\*  
V. Ramaswami et al., Analysis of the Link Error Monitoring Protocols in the Common Channel Signaling Network, IEEE/ACM Transactions on Networking, vol. 1, No. 1, Feb. 1993, pp. 31-47.  
Ming H. Chan et al., Prioritized Statistical Multiplexing of PCM Sources, IEEE/ACM Transactions on Networking, vol. 3, No. 5, Oct. 1995, pp. 549-559.  
Zsehong Tsai et al., Performance Analysis of Two Echo Control Designs in ATM Networks, IEEE/ACM Transactions on Networking, vol. 2, No. 1, Feb. 1994, pp. 30-39.

*Primary Examiner*—Jean Corrielus  
(74) *Attorney, Agent, or Firm*—The Eclipse Group

(57) **ABSTRACT**

A pulse code modulation modem system is configured to transmit data from a first modem to a second modem over the public switched telephone network (PSTN). The PSTN employs robbed bit signaling (RBS) such that symbols affected by RBS arrive at the second modem in a periodic manner based on a period of six symbols. The modem system is configured such that signal segments are formatted and transmitted with six symbols per segment. After obtaining symbol synchronization, the second modem initializes a modulo-6 symbol counter such that the zero count corresponds to the first symbol of each received signal segment. Those symbols affected by RBS are identified and analyzed to determine optimized signal point constellations that may be used to compensate for the RBS on a symbol-by-symbol basis during subsequent encoding and decoding. Upon a loss of synchronization, the second modem resets its modulo-6 counter in response to the detection of the first symbol in a subsequent signal segment. In this manner, the modem system can again use the optimized signal point constellations determined previously.

**18 Claims, 5 Drawing Sheets**

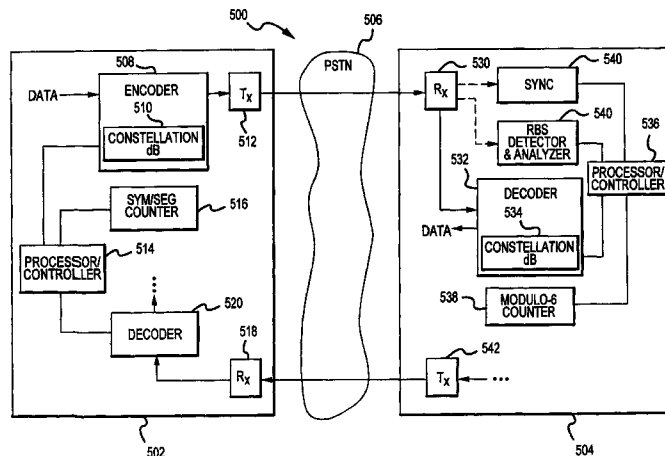

# US RE38,678 E

Page 2

## U.S. PATENT DOCUMENTS

5,541,967 A	*	7/1996	Gluska et al. ....	375/364	5,875,229 A	2/1999	Eyuboglu et al.	
5,550,820 A		8/1996	Baran		5,943,361 A	8/1999	Gilhousen et al.	
5,590,161 A	*	12/1996	Meyn et al. ....	375/368	5,970,089 A	10/1999	Alelyunas et al.	
5,598,435 A	*	1/1997	Williams .....	375/261	5,991,348 A	11/1999	Alelyunas et al.	
5,623,516 A	*	4/1997	Brownlie et al. ....	375/259	5,995,558 A	11/1999	Betts et al.	
5,687,199 A	*	11/1997	Dupuy .....	375/354	5,999,582 A	12/1999	Rice	
5,729,226 A	*	3/1998	Betts et al. ....	341/94	6,072,825 A	6/2000	Betts et al.	
5,754,594 A	*	5/1998	Betts et al. ....	375/285	6,081,567 A	6/2000	Olafsson	
5,761,247 A	*	6/1998	Betts et al. ....	375/316	6,118,813 A	9/2000	Lai	
5,784,405 A	*	7/1998	Betts et al. ....	375/222	6,144,736 A	11/2000	Koenig et al.	
5,812,075 A	*	9/1998	Betts et al. ....	341/94	6,173,015 B1	1/2001	Eyuboglu et al.	
5,812,602 A		9/1998	Humblet		6,181,752 B1	1/2001	Kim	
5,822,359 A	*	10/1998	Bruckert et al. ....	375/145	6,198,776 B1	3/2001	Eyuboglu et al.	
5,822,371 A	*	10/1998	Goldstein et al. ....	375/242	6,201,842 B1	3/2001	Kim	
5,825,816 A	*	10/1998	Cole et al. ....	375/222	6,212,207 B1	* 4/2001	Nicholas .....	370/523
5,825,823 A	*	10/1998	Goldstein et al. ....	375/286	6,256,353 B1	7/2001	Alelyunas et al.	
5,838,724 A	*	11/1998	Cole et al. ....	375/222	6,343,101 B1	1/2002	Dong et al.	
5,841,842 A		11/1998	Baum et al.		6,463,103 B1	10/2002	Dong et al.	
5,870,429 A		2/1999	Moran, III et al.					

\* cited by examiner

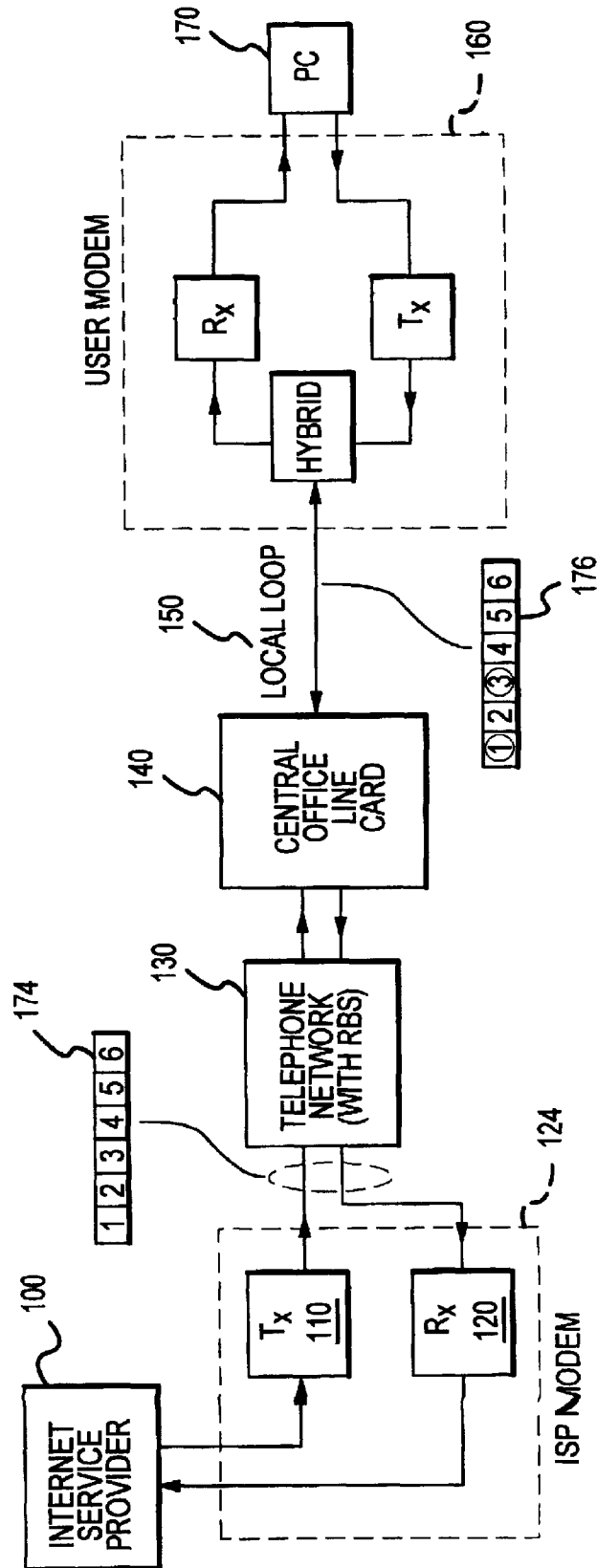

FIG. 1



FIG.2



FIG.3



FIG.4

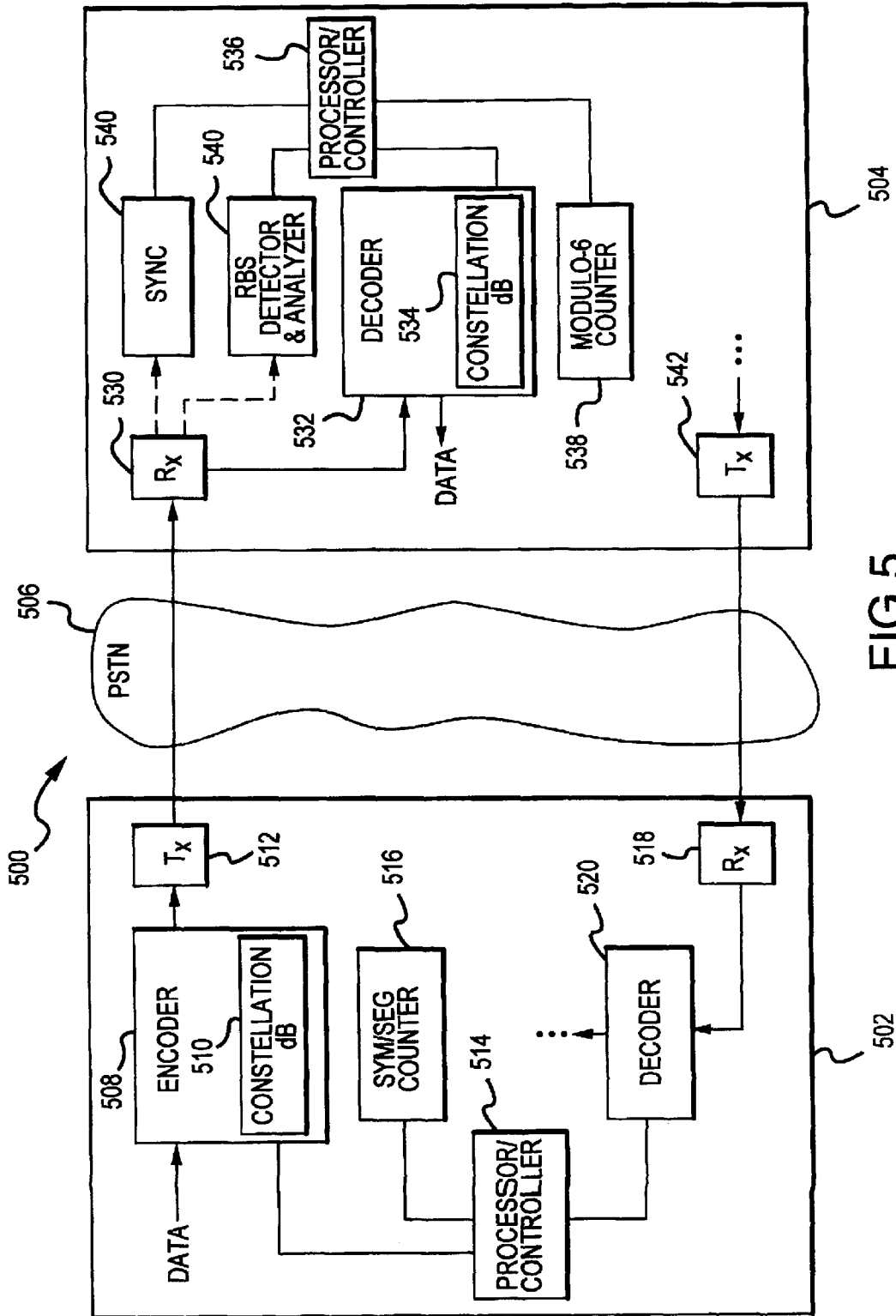

FIG. 5

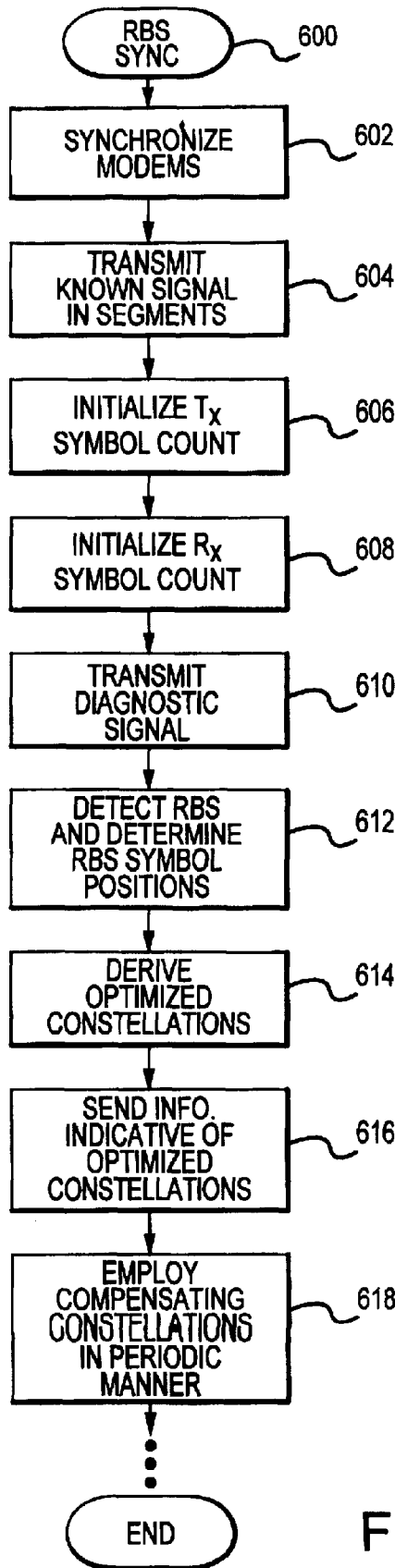

FIG.6

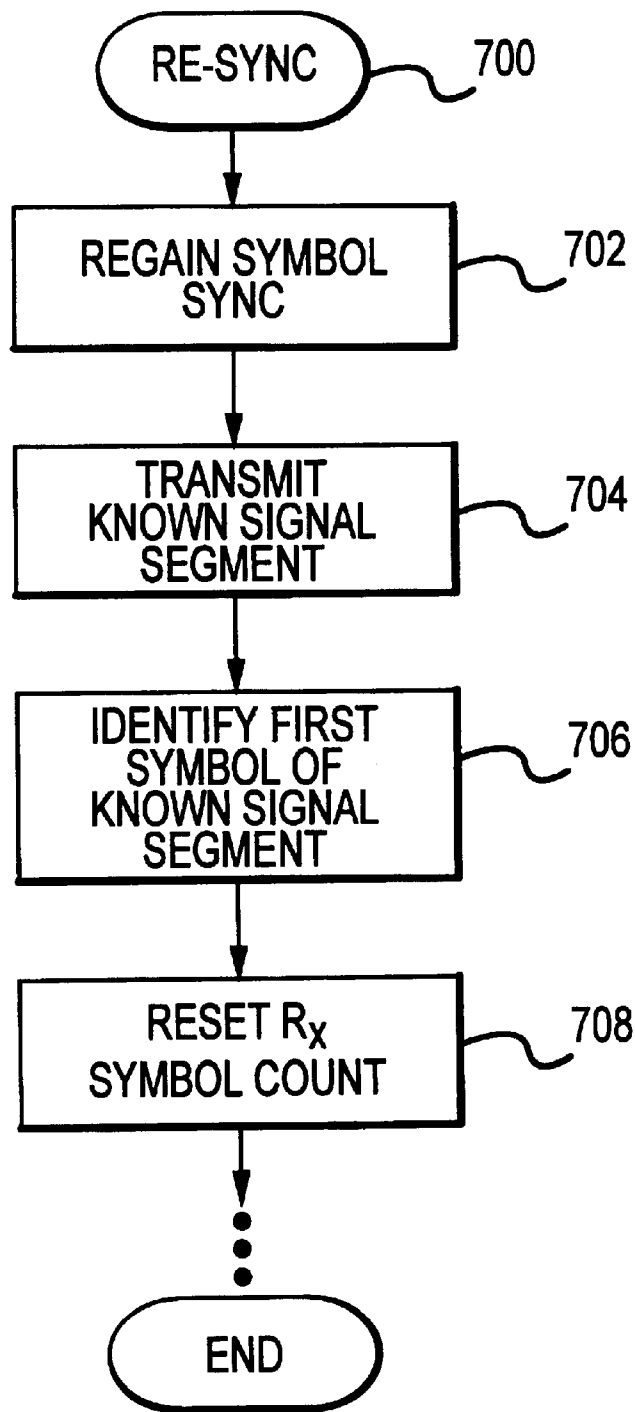

FIG.7

**METHOD AND APPARATUS FOR  
SYNCHRONIZING A DATA  
COMMUNICATIONS SYSTEM TO A  
PERIODIC DIGITAL IMPAIRMENT**

**Matter enclosed in heavy brackets [ ] appears in the original patent but forms no part of this reissue specification; matter printed in italics indicates the additions made by reissue.**

FIELD OF THE INVENTION

The present invention relates generally to synchronization techniques used in data communication systems, e.g., modem systems, that transmit data between remote locations. More specifically, the present invention relates to a synchronization technique for use with a data communication system that introduces digital impairments, such as robbed bit signaling, to a transmit signal.

BACKGROUND OF THE INVENTION

Digital communication systems, such as modem systems, are well known in the prior art. Such systems typically employ timing recovery techniques that are utilized to recover the symbol rate at which the data is transmitted. Such systems also use synchronization techniques that are utilized to align the receiver clock with the transmitter clock. Synchronization signals are often transmitted near the beginning of a "handshaking" procedure, during a receiver training procedure, or periodically during data transmission (to resynchronize the receive modem with the transmit modem). The prior art is replete with various timing recovery and synchronization techniques; several timing recovery schemes are discussed in Lee & Messerschmitt, *DIGITAL COMMUNICATION*, pp. 737-764 (2d ed. 1996), the contents of which are incorporated herein by reference.

The current 56 kbps modem systems take advantage of the digital nature of the public switched telephone network (PSTN). The theoretical maximum data rate of 64 kbps per channel may not be realized in conventional 56 kbps modem systems that employ robbed bit signaling (RBS) to facilitate control signaling between network nodes. A particular data transmission may pass through a number of network nodes; each link may introduce RBS such that several bits are eventually robbed from the originally transmitted data codewords. The modem system can partially compensate for this type of digital impairment if it can identify the affected bits or the affected codewords.

For a given link in a 56 kbps modem transmission, RBS typically removes the least significant bit from the transmitted PCM codeword and replaces the bit with signaling information. The robbed bits are commonly forced to "ones" by the central offices, which effectively reduces the number of signal points in the signal point constellations utilized to decode the codewords affected by RBS. If the receiving modem can identify those symbols affected by the RBS, then different signal point constellations may be employed in a symbol-by-symbol basis to optimize performance and compensate for the RBS. Accordingly, a technique for synchronizing the receive modem to the RBS is needed to facilitate the application of signal point constellations to RBS-tainted symbols.

In current 56 kbps modem systems, RBS may occur in any given network link. In addition, symbols may be transmitted as a "continuous" stream or arranged in a number of signal segments or data frames having a particular number of symbols per segment or frame. The receive modem is

configured to obtain and maintain synchronization with the transmit modem or network clock for purposes of timing and proper decoding. Present systems may utilize a special synchronization signal format or a symbol counting technique to monitor occurrences of RBS on a symbol-by-symbol basis. However, such techniques may break down if the receiver modem loses synchronization with the transmit modem. When such a receiver modem regains proper synchronization, it may not be possible to readily identify those symbols affected by RBS; the receiver modem may apply RBS-correcting signal point constellations where such correction is unnecessary. Untimely use of such corrective measures may introduce an undesirable number of decoding errors.

Therefore, a technique is needed to address the above disadvantages and shortcomings of prior art 56 kbps modem systems.

SUMMARY OF THE INVENTION

Accordingly, it is an advantage of the present invention that an improved synchronization procedure for use in a data communication system is provided.

Another advantage of the present invention is that it provides a mechanism for synchronizing a receive modem to a digital impairment, such as robbed bit signaling (RBS), that is introduced to the transmit signal.

Another advantage is that the present invention provides for a modem system that obtains RBS synchronization upon receiver/transmitter synchronization.

A further advantage is that RBS synchronization may be easily reestablished subsequent to a loss of receiver/transmitter synchronization.

Another advantage of the present invention is that the modem system can employ corrective signal point constellations to encode and decode RBS-tainted symbols in a reliable manner.

The above and other advantages of the present invention are carried out in one form by a synchronization method for use in a data communication system having a first device configured to communicate with a second device, where the communication network between the two devices introduces digital impairments to a transmit signal such that the digital impairments arrive at the second device in a periodic manner based on a period of N symbols. The method may begin by transmitting a plurality of signal segments from the first device to the second device, where each of the signal segments is represented by an integer multiple of N symbols. The second device then obtains synchronization associated with symbols transmitted by the first device.

BRIEF DESCRIPTION OF THE DRAWINGS

A more complete understanding of the present invention may be derived by referring to the detailed description and claims when considered in connection with the Figures, where like reference numbers refer to similar elements throughout the Figures, and:

FIG. 1 is a block diagram of an exemplary 56 kbps pulse code modulation (PCM) modem environment;

FIGS. 2-4 depict exemplary transmit signals with symbols affected by RBS;

FIG. 5 is a block diagram of an exemplary modem system in which the synchronization techniques of the present invention may be incorporated;

FIG. 6 is a flow diagram of an RBS synchronization process that may be carried out by the modem system shown in FIG. 5; and



FIG. 7 is a flow diagram of a resynchronization process that may be performed by the modem system shown in FIG. 5.

#### DETAILED DESCRIPTION OF PREFERRED EXEMPLARY EMBODIMENTS

FIG. 1 shows an exemplary 56 kbps pulse code modulation (PCM) based modem environment in which the present invention may operate. An internet service provider (ISP) or central site 100 is digitally connected to a telephone network 130 through a transmitter 110 and a receiver 120 resident at an ISP modem 124. Telephone network 130 is connected to a local loop 150 through a central office line card 140. Line card 140 typically has a PCM codec (not shown) implemented therein. Local loop 150 is connected to a user's personal computer (PC) 170 at the user's site through the user's modem 160. As can be appreciated by those skilled in the art, the connection between transmitter 110 to telephone network 130 is a digital connection with a typical data rate of about 64 Kbps. Since the parameters of telephone network 130 and line card 140 are dictated and set by the telephone company's specifications and operation (and particularly their use of the  $\mu$ -law signal point constellation), transmitter 110 needs to transmit the digital data in a particular format to fully exploit its digital connection to telephone network 130. Those skilled in the art will appreciate that the system depicted in FIG. 1 may employ any number of known signal processing, coding, and decoding techniques related to, e.g.,  $\mu$ -law signal point constellations, shell mapping, spectral control, equalizer training, and the like. For the sake of brevity, such known techniques and systems are not described in detail herein. It should also be noted that the principles of the present invention are not limited to modem applications and that the present invention may be suitably modified or configured for deployment in any number of data communication systems.

Generally, the typical PCM modem system formats digital data for transmission from ISP modem 124 to user modem 160, where the digital data is retrieved for use by PC 170. The data may be arranged into data symbols and encoded via any number of techniques such as  $\mu$ -law mapping. The data symbols may then be further processed with spectral control or other signal conditioning schemes prior to being transmitted as one or more signal segments at a particular symbol rate to telephone network 130. User modem 160 eventually receives the data symbols and thereafter decodes the data to obtain the original digital data. To function efficiently, user modem 160 should be synchronized with ISP modem 124. Consequently, user modem 160 may include a timing recovery scheme that recovers the transmitted symbol rate and synchronizes the receiver at user modem 160 with transmitter 110.

Due to the digital nature of telephone network 130 and the design of current 56 kbps modem systems, digital impairments may be present within a data communication channel. For example, present 56 kbps modem systems may employ techniques to compensate for robbed bit signaling (RBS) which may occur in the digital links within telephone network 130. Although in theory 64 kbps may be allocated for any given channel, some of the bits may be "robbed" and replaced with data for use with control signaling on a link between network nodes. Each data symbol typically includes a 7-bit PCM codeword and a sign bit; the robbed bits are periodically taken from the least significant bit positions associated with the transmitted PCM codewords. The central office codec may assign "ones" to the robbed bits for purposes of decoding. Thus, unless otherwise compensated for, RBS can introduce decoding errors to the transmitted data.

Any given communication channel may be susceptible to any number of robbed bits associated with multiple network links within telephone network 130. For example, for a given network link, RBS may occur once every sixth PCM codeword, i.e., once every sixth symbol. On a subsequent link, another symbol position may be affected by RBS. FIG. 1 depicts an exemplary signal segment 174 transmitted by ISP modem 124 (for purposes of this example, signal segment 174 is six symbols long). For the particular end-to-end channel between ISP modem 124 and user modem 160, telephone network 130 may introduce RBS with respect to any number of symbols associated with signal segment 174. In this example, RBS has occurred at symbol positions 1 and 3, as indicated in signal segment 176. It should be appreciated that the present invention is not limited to any specific signal segment length and that the specific symbol locations associated with RBS may differ than that shown and described herein.

In accordance with the present invention, telephone network 130 operates such that symbols affected by RBS arrive at user modem 160 in a periodic manner based on a period of N symbols. Thus, for the example shown in FIG. 1, RBS would occur every six symbols for symbol positions 1 and 3. FIG. 2 depicts an exemplary transmit signal formatted as a continuous stream of symbols. As shown, the RBS occurring at the first symbol periodically occurs every sixth symbol, i.e., at the seventh symbol, the thirteenth symbol, and so on. Likewise, the RBS occurring at the third symbol periodically occurs every sixth symbol, i.e., at the ninth symbol, the fifteenth symbol, and so on. The present invention takes advantage of this periodic nature of the RBS by defining and formatting all transmitted signal segments such that they are represented by an integer multiple of N symbols, where N is the period of RBS occurring at user modem 160 (although not a requirement of the present invention, the preferred exemplary embodiment described herein operates with N=6 for compatibility with the RBS period found in current 56 kbps modem systems).

FIG. 3 depicts an exemplary transmit signal defined by a plurality of signal segments, each having a length of six symbols. As shown, the periodic nature of the RBS, in conjunction with the arrangement of the signal segments, ensures that the symbol positions affected by the RBS are repeated for each six-symbol signal segment. In other words, the RBS-tainted symbols are the first and third symbols of each signal segment. It should be noted that the principles of the present invention are applicable to transmit signals that are defined by any integer multiple of N symbols, e.g., an integer multiple of six for the above examples. FIG. 4 depicts another exemplary transmit signal defined by a plurality of twelve-symbol signal segments. In this example, the RBS-tainted symbols occur at the first, third, seventh, and ninth symbols of each signal segment. In general, the present invention takes advantage of this periodic characteristic to simplify the synchronization process with respect to RBS and to effectively identify and compensate for those symbols affected by RBS.

FIG. 5 is a block diagram of a preferred exemplary modem system 500 that incorporates the synchronization features of the present invention; it will be appreciated, however, that the present invention can be implemented in combination with any number of different synchronization, timing recovery, and other signal processing techniques known in the art. For example, many suitable techniques are described in Lee & Messerschmitt, DIGITAL COMMUNICATION (2d ed. 1996), which is incorporated herein by reference. Accordingly, the particular implementations

shown and described herein are merely exemplary and are not intended to limit the scope of the present invention in any way. Indeed, for the sake of brevity, various timing recovery, automatic gain control (AGC), synchronization, training, decoding, and other techniques employed by modem system 500 may not be described in detail herein.

It should be appreciated that the functional blocks depicted in FIG. 5 are merely exemplary and are not intended to represent physical limitations of modem system 500. These, and other functional elements of modem system 500, may be implemented with any number of semiconductor devices, including memory elements configured to store data, functional parameters, software instructions, and other information, and microprocessors configured to carry out the various processes described herein. Furthermore, modem system 500 may include conventional hardware or software elements configured to perform well known operations related to digital signal processing and/or data transmission; such elements are not described in detail herein.

Generally, modem system 500 includes a first modem, e.g., modem 502, and a second modem, e.g., modem 504. Modems 502, 504 are generally configured in accordance with known principles to communicate via the public switched telephone network (PSTN) 506. In current 56 kbps modem systems, PSTN 506 typically introduces RBS to a number of transmitted symbols, as described above.

First modem 502 may include a processor/controller 514 configured to carry out various tasks associated with the operation of modem 502. Although not shown, modem 502 may incorporate additional processors or control elements as necessary to suitably support its operation. Processor/controller 502 may suitably interact with other functional components of modem 502 to thereby access and manipulate data or monitor and regulate the operation of modem 502.

First modem 502 preferably includes an encoder 508 configured to encode digital data in accordance with the particular encoding protocol employed by modem system 500. For example,  $\mu$ -law or A-law encoding techniques are used in conventional modem systems in accordance with well-established standards. The output signal generated by encoder 508 may include information for transmission during a data mode, synchronization or training signals for transmission during an initialization mode, or control or other signaling data employed by modem system 500. A signal point constellation database 510 may be associated with encoder 508, as depicted in FIG. 5. It should be appreciated that database 510 need not be an integral part of encoder 508 and that modem 502 may implement database 510 in a different manner than that shown. As described in more detail below, database 510 may be employed by modem 502 to store a plurality of signal point constellations associated with specific symbol positions within a segment. Such constellations are suitably used to facilitate the transmission of signal segments from modem 502 to modem 504. For example, compensating signal point constellations may be derived and stored for use during encoding and decoding of signal points associated with RBS to optimize the performance of modem system 500 in the presence of RBS.

Modem 502 includes a transmitter 512, which is configured to transmit encoded data symbols in accordance with general PCM techniques. In accordance with one aspect of the present invention, modem 502 is configured to transmit signal segments that have been formatted such that each signal segment is represented by an integer multiple of N symbols, where N is the period with which RBS-tainted symbols repeat at modem 504 (as described above).

Processor/controller 514 may be configured to perform such formatting to ensure that each signal segment is a multiple of N symbols long. In addition, modem system 500 may be governed by applicable standards such that certain signals, e.g., predetermined training signals, control signals, and the like, are defined to be a multiple of N symbols long. In accordance with one aspect of the present invention, a period of silence may be transmitted by modem 502 in the form of one or more signal segments having a multiple of N "zero" symbols.

Modem 502 may employ a symbol or segment counter 516 to monitor the relative symbol positions associated with signal segments transmitted by modem 502. Counter 516 may be employed to enable encoder 508 to associate particular signal point constellations with different symbol counts within a segment. In one embodiment where signal segments are represented by six symbols, counter 516 may be configured as a modulo-6 counter. Counter 516 may be configured to function in accordance with any number of known digital signal processing techniques.

Modem 502 includes a receiver 518, which may be configured in accordance with conventional modem technology. Receiver 518 is configured to receive data from modem 504; such data may include encoded information bits, control signals, functional parameters or identifiers, and any other data employed by conventional modem systems. For example, and as described in more detail below, modem 504 may be configured to send information indicative of optimized signal point constellations to modem 502 for use during transmission of subsequent signal segments. Of course, modem 502 may employ any suitable alternative device or technique for receiving the optimized signal point constellations from modem 504. A decoder 520 may be used to decode any signals transmitted by modem 504 to modem 502, including the signal that conveys the optimized constellations.

Signal segments are suitably transmitted over a forward channel to modem 504 in accordance with conventional transmission techniques. As described above, signal segments transmitted through PSTN 506 may be subject to RBS in any number of network links. Eventually, the signal segments are received at a receiver 530 located at modem 504; modem 504 processes the received signals to obtain the original digital data encoded by modem 502. It should be noted that receiver 530 may include any number of additional components (that may be known in the art) for decoding, gain control, timing recovery, equalization, conditioning, or other processing of the received signal.

Like modem 502, modem 504 may include a processor/controller 536 configured to carry out various tasks associated with the operation of modem 504. Processor/controller 536 may suitably interact with other functional components of modem 504 to access and manipulate data or monitor and regulate the operation of modem 504. For example, processor/controller 536 may be configured to operate in conjunction with a decoder 532 to suitably decode the received symbols in accordance with the same encoding scheme employed by encoder 508. Decoder 532 may be configured in accordance with known signal processing techniques. As with encoder 508, decoder 532 may have a signal point constellation database 534 associated therewith. Database 534 is preferably utilized to store different signal point constellations that may be optimized for use with particular symbol counts within a given signal segment. In accordance with the present invention, the same optimized signal point constellations may be used for encoding and decoding of individual symbols when modem 504 is syn-

chronized with modem **502** and when counters **516** and **538** are aligned. This enables modem system **500** to effectively compensate for RBS or channel characteristics on a symbol-by-symbol basis.

A symbol counter, such as a modulo-6 symbol counter **538**, is preferably utilized to enable modem **504** to correctly apply the appropriate signal point constellation to the received symbols. To enable synchronized operation of encoder **508** and decoder **532**, processor/controller **536** may initialize or reset counter **538** in accordance with a synchronization scheme **540** performed by modem **504**. It should be noted that synchronization scheme **540** may perform any number of conventional synchronization techniques known to those skilled in the art and that the present invention is not limited to any particular synchronization methodology. In the preferred embodiment, synchronization scheme **540** may suitably detect one or more synchronization signal segments transmitted by modem **502** during a start-up period or during a re-synchronization procedure.

After detection of such a synchronization signal, modem **504** may reset counter **538** in response to receipt of an initial signal segment transmitted after the synchronization signal. For example, modem **504** may reset counter **538** upon or after receipt of a first symbol of a subsequent signal segment that follows the initial segment. Alternatively, the resetting of counter **538** may be prompted by the detection or receipt of any suitable reference-position symbol (i.e., other than the first symbol) associated with the initial signal segment or associated with a subsequent signal segment. Of course, use of a different reference symbol position may require additional processing to compensate for any applicable offset between counters **538** and **516**. Resetting counter **538** based upon a subsequent signal segment may be desirable in applications where it is difficult to accurately or efficiently detect the first symbol of the initial signal segment immediately received after the synchronization signal. Eventually, when modem **504** is synchronized with modem **502**, counter **538** will maintain a symbol count consistent with modem **502**.

Once modem **504** is synchronized with modem **502**, processor/controller **536** may also serve to designate which signal point constellation should be used by decoder **532** to decode the current symbol. As described above, modem **502** preferably encodes data using signal point constellations (that may differ from one another) that have been optimized to compensate for RBS. Consequently, to avoid introducing decoding errors, modem **502** and modem **504** should use the same constellations on a symbol-by-symbol basis. It should be noted that the constellations may also be optimized according to any number of channel characteristics, the particular configuration of receiver **530**, or the use of digital pads. In the context of the present invention, a "digital pad" may be a circuit configuration or a digitally implemented process applied to the transmitted codewords that emulates the effect of an analog attenuator. For example, a digital pad may employ digital techniques such as conversion tables to transform a codeword representing a given signal point magnitude into a different codeword representing a reduced signal point magnitude.

As described above, modem system **500** preferably uses compensating constellations that are optimized in response to the presence and effects of RBS. Accordingly, modem **504** may include an RBS detector/analyzer **540**, which may be configured in accordance with conventional methodologies. RBS detector/analyzer **540** preferably detects the presence of RBS in a received signal and determines the symbol positions, relative to each of the received signal segments,

where RBS was introduced by PSTN **506**. RBS detector/analyzer **540** (or any suitable functional component resident at modem **504**) may be further configured to derive, for each symbol position that may be affected by RBS, the compensating signal point constellation for use during subsequent encoding and decoding of symbols located at that position. The determination of the optimized signal point constellations may be performed during transmission of one or more known training or diagnostic signal segments (after modem **504** has been synchronized with modem **502**).

Once modem **504** has determined the preferred signal point constellations for use during subsequent data transmission, a transmitter **542** is preferably utilized to send information indicative of the optimized signal point constellations to modem **502**. In the preferred embodiment, the information transmitted by transmitter **542** is encoded prior to transmission over PSTN **506**. Upon receipt of this information, modem **502** performs decoding and processing to obtain the optimized signal point constellations for subsequent use by encoder **508**.

FIG. 6 is a flow diagram of an RBS synchronization process **600** that may be performed by a modem system, such as modem system **500**. Process **600** may be performed in addition to, or as an integral part of, one or more other processes related to the overall functionality of modem system **500**. Furthermore, process **600** merely illustrates how the present invention may be implemented in an exemplary modem system, the specific number and ordering of tasks may not necessarily be as shown and described herein.

Process **600** may begin with a task **602**, during which modem **504** is synchronized to modem **502**. In the preferred embodiment, a predetermined synchronization signal is transmitted from modem **502** during a start-up period; modem **504** may also be trained during this period. Although not a requirement of the invention, the synchronization signal may be formatted into segments each having N symbols, where N is a multiple of the RBS period as described above.

Following task **602**, a task **604** may be performed to cause modem **502** to transmit a known signal having one or more signal segments, each signal segment being represented by an integer multiple of N symbols. For purposes of this exemplary embodiment, N equals the RBS period of six (common to current 56 kbps modem systems). In one preferred embodiment, this known signal is configured in a pseudo-random manner, which enables modem **504** to train the equalizers (not shown) in receiver **530** and to train the echo cancelers (not shown) in transmitter **512**. Receiver **530** may also utilize this known signal to analyze the effects of RBS, as described in more detail below in connection with a diagnostic signal. Upon transmission of the first symbol of the pseudo-random signal, counter **516** (see FIG. 5) is preferably initialized (task **606**) to begin monitoring the symbol positions associated with each subsequent signal segment.

After (or in response to) receipt of an initial segment associated with the pseudo-random signal, a task **608** is performed to initialize counter **538** associated with modem **504**. As described above, the initialization of counter **538** may be delayed until one or more subsequent signal segments are received at modem **504** to ensure that counter **538** is accurately set to a zero state to identify the first symbol in a signal segment. Consequently, this first symbol is associated with the same zero count maintained by counters **516** and **538** located at modems **502** and **504**, respectively. In this

respect, counter **538** may be considered to be synchronized or aligned with counter **516**. As described above, counter **538** is preferably a modulo-6 counter in the exemplary embodiment; counter **538** automatically resets itself after counting six symbols. Thus, as long as modem **502** continues to transmit signal segments having six symbols, counter **538** will properly track counter **516**.

The above counting scheme is preferably maintained regardless of the information conveyed by each symbol. For example, the present invention is configured such that periods of silence (e.g., symbols with all bits set to zero, symbols corresponding to signal points having the lowest magnitude relative to other signal points used in the current constellation, or the like) may be transmitted as one or more signal segments (the only requirement is that the signal segment contain the appropriate number of symbols). In contrast, prior art systems that rely solely upon clock estimation techniques may not function effectively during periods of silence. Such prior art systems may not be able to accurately maintain a symbol count during long or arbitrary periods of silence. For example, to resume transmission after an arbitrary period of silence, prior art systems may perform a resynchronization process to align the receiver with the transmitter and a subsequent resynchronization process to align the RBS-framing with that of the transmitter. A prior art system that employs symbol counters must re-align the transmitter and receiver counters by, e.g., transmitting a reference sequence to reset the counters or performing a suitable reinitialization procedure.

In contrast to such prior art systems, if clock synchronization has been maintained by modem system **500** throughout a period of silence, then no further synchronization processes are required because counters **516** and **538** will have preserved their alignment during the silence. If, however, clock synchronization is not maintained, then receiver **530** may first resynchronize its clock, then align counter **538** to counter **516** by detecting a transition from one segment to another using the techniques described below in connection with process **700**.

After counter **538** has been initialized, a diagnostic signal containing at least one signal segment may be transmitted from modem **502** to modem **504** (task **610**). Each diagnostic signal segment is formatted in accordance with the above principles; in this example, each diagnostic signal segment is a multiple of six symbols long. It should be appreciated that any diagnostic signal having suitable characteristics may be transmitted during task **610**. For example, the preferred embodiment employs a diagnostic signal that contains most of the  $\mu$ -law codewords likely to be used for the particular transmission. Thus, an exemplary diagnostic signal may include more than 100 symbols representing various constellation signal points. It should be noted that the particular format of the diagnostic signal may vary from system to system. The diagnostic signal is received by modem **504** and analyzed during a task **612**.

During task **612**, RBS detector/analyzer **540** (see FIG. **5**) suitably detects the effect of RBS in the received signal segments and determines the symbol positions (if any) where RBS was introduced to the signal. Due to the periodic nature of the RBS, detector/analyzer **540** need only determine the RBS-affected symbol positions in any one signal segment; all other signal segments should be similarly affected. Task **612** may employ any number of conventional detection schemes known to those skilled in the art. Counter **538** may be accessed or monitored during task **612** to suitably identify the symbol count associated with RBS-tainted symbols. A task **614** may also be performed to derive

optimized signal point constellations for use during subsequent encoding and decoding of symbols processed by modem system **500**. One form of optimized constellation is a compensating constellation for use during encoding and decoding of symbols affected by RBS. Other optimized constellations may be derived in response to conventional line probing techniques that determine transmission characteristics of the current channel. Task **614** is preferably performed to derive a constellation for each symbol position associated with the formatted segment length, e.g., six for the example described herein. The different signal point constellations for the various symbol positions may be stored in database **534**. It should be noted that modem system **500** need not employ a unique signal point constellation for each symbol position.

For purposes of the present invention, task **614** may "derive" the optimized signal point constellations by analyzing the RBS information obtained in connection with the diagnostic signal and selecting from a group of predetermined constellations. In this manner, any number of optimized signal point constellations can be stored at modem **504**; such stored constellations may be optimized in accordance with any number of factors such as the transmit power level, the use of digital pads and the amount of attenuation caused by the digital pads, the location of digital pads relative to where RBS is introduced, and other known sources of digital impairments. Accordingly, modem system **500** need not individually determine new signal point constellations for each transmit session.

Following task **614**, a task **616** may be performed to cause modem **504** to send information indicative of the optimized signal point constellations, and their corresponding symbol positions, to modem **502**. Processor/controller **536** may be configured to format the data into a form suitable for encoding and transmission by transmitter **542**. Such techniques are generally known in the digital signal processing field. The information is eventually received by receiver **518** at modem **502**, decoded by decoder **520**, and appropriately processed. In the preferred embodiment, the particular signal point constellations, with their corresponding symbol positions, are stored in database **510** for subsequent use during encoding.

A task **618** may be subsequently performed to cause modem system **500** to employ the compensating signal point constellations in the periodic manner with which RBS is introduced into the transmit signal. In other words, if the current channel causes RBS to be present in the first and third symbol positions when received at modem **504**, then the appropriate signal point constellations "assigned" to the first and third symbol positions will be used whenever those particular symbols are encoded and decoded. As described above, other optimized constellations may be employed in this periodic manner, whether or not they compensate for the presence of RBS.

The present invention takes advantage of the periodic nature of RBS within signal segments received at modem **504** to effectively compensate for the RBS. In modem **504** remains synchronized with modem **502**, then the occurrence and affect of RBS within a signal segment can be predictable on a symbol-by-symbol basis (as long as the signal segments are consistently arranged to have the specified number of symbols). However, in practical modem systems, synchronization may be lost from time to time. Prior art modem systems may require a reanalysis of the channel characteristics or the effects of RBS upon resynchronization to redetermine the individual signal point constellations. In contrast, in accordance with one aspect of the present

invention, if modem 504 loses and thereafter regains synchronization, the symbol locations affected by RBS remain unchanged and the same optimized signal point constellations may be utilized as though synchronization was never lost. This feature enables modem system 500 to regain an optimized transmission mode in a reduced amount of time compared to prior art modem systems.

FIG. 7 is a flow diagram that depicts a resynchronization process 700 that may be performed by modem system 500 when modem 504 loses synchronization with modem 502. The following description of process 700 assumes that modem 502 maintains "synchronization" with its symbol counter 516 and/or a network counter (not shown) at all times. Process 700 may begin with a task 702, during which modem 504 regains symbol synchronization with modem 502. Those skilled in the art will recognize that task 702 may be initiated by modem 504 upon a determination that the initial synchronization has been lost. Various renegotiation, signaling, and conventional symbol resynchronization procedures may be performed by modem system 500 to enable modem 504 to regain symbol synchronization with modem 502.

Following task 702, the symbol timing of modem 504 is preferably aligned with modem 502. However, the respective symbol counters 538 and 516 may not be operating in a synchronized manner. If symbol counters 538 and 516 are not aligned, then the various optimized signal point constellations will not be applied in a consistent manner during encoding and decoding. Accordingly, a task 704 is preferably performed to cause modem 502 to transmit one or more repetitions of a known signal segment (having six symbols in accordance with the above example). In an exemplary embodiment, this known signal segment may be similar to a V.34 Modulation Parameter (MP) sequence or any suitable segment recognizable by modem 504. Task 704 may be performed in response to the procedure described above in connection with task 702.

Modem 504 eventually receives the known signal segment and determines its significance as a reference sequence. Next, a task 706 is preferably performed, during which modem 504 suitably identifies a reference-position symbol of the known signal segment (or a reference-position symbol of a subsequent signal segment). In the preferred embodiment, task 706 identifies the first symbol of the known signal segment. Modem 504 may employ conventional techniques to perform task 706. For example, processor/controller 536 (see FIG. 5) may recognize the known signal segment and, consequently, determine the appropriate symbol count corresponding to the symbols in the known signal segment.

Preferably, after modem 504 identifies the first symbol of the known signal segment, a task 708 is performed. Task 708 resets counter 538 in response to the identification of the first symbol of the known signal segment. In other words, task 708 causes counter 538 to again associate the first symbol of received signal segments with a zero count. Thus, following completion of task 708, counter 538 is consistent with counter 516 and modem 504 is resynchronized with modem 502 with respect to symbol timing and monitoring of symbol positioning.

Following task 708, process 700 may end and modem system 500 may proceed in accordance with the above principles. Notably, the same optimized signal point constellations obtained prior to the loss of initial synchronization can be utilized during subsequent encoding and decoding. This enables modem system 500 to take advantage of

the consistent characteristics of the communication channel and the effects of RBS, neither of which should substantially vary during a given communication session over the same end-to-end link. This aspect of the present invention allows modem system 500 to efficiently establish a normal operating mode without having to perform a lengthy reanalysis of the RBS symbol positions or a redetermination of the optimized signal point constellations. It should be appreciated that, during such renegotiation procedures, modem system 500 may be configured to alter the data rate, which results in the use of signal point constellations having more or less signal points than before the renegotiation. In such a situation, modem system 500 may utilize the RBS information obtained during the previous analysis and apply such information to derive or select the appropriate signal point constellations for use with subsequent transmissions at the new data rate. Again, the leveraging of the previously obtained information enables modem system 500 to efficiently determine optimized signal point constellations without having to repeat the entire RBS analysis.

In summary, the present invention provides an improved synchronization procedure for use in modem system. The present invention provides a mechanism for synchronizing a receive modem to a digital impairment, such as RBS, that is introduced to the transmit signal. In accordance with one aspect of the invention, a modem system can readily obtain RBS synchronization upon synchronization of the receive modem with the transmit modem. In addition, RBS synchronization and a corresponding RBS compensation technique may be easily reestablished subsequent to a loss of synchronization between the receive modem and the transmit modem. An exemplary modem system employs corrective signal point constellations to encode and decode RBS-tainted symbols in a reliable manner.

The present invention has been described above with reference to various exemplary embodiments. However, those skilled in the art will recognize that changes and modifications may be made to the preferred embodiments without departing from the scope of the present invention. For example, the particular signal segment format may differ than that described herein. In addition, various signal segments have been referred to (e.g., synchronization signal, subsequent signal segment, initial segment, MP sequence) for the sake of convenience and to better describe the invention. However, those skilled in the art will appreciate that these designations in no way limit the practical application of the invention. These and other changes or modifications are intended to be included within the scope of the present invention, as expressed in the following claims.

What is claimed is:

1. A synchronization method for use in a data communication system having a first device configured to communicate with a second device over a communication network, said communication network employing robbed bit signaling (RBS) such that symbols affected by RBS arrive at said second device in a periodic manner based on a period of N symbols, said method comprising the steps of:

transmitting a plurality of signal segments from said first device to said second device, each of said signal segments being represented by an integer multiple of N symbols;

receiving said signal segments at said second device;

synchronizing said second device to symbols transmitted by said first device;

initializing a modulo-N symbol counter at said second device in response to receipt of an initial signal seg-

## 13

ment by said second device, said modulo-N symbol counter being synchronous to a symbol count associated with said signal segments;

detecting the effect of RBS in a received signal segment, said detecting step being performed by said second device;

determining at least one symbol position, relative to said received signal segment, where RBS was employed by said communication network;

identifying a reference-position symbol of one of said signal segments after loss of an initial symbol synchronization between said second device and said first device; and

resetting said modulo-N symbol counter in response to said identifying step.

2. A method according to claim 1, further comprising the step of deriving, for each of said at least one symbol position, a compensating signal point constellation for use during subsequent encoding and decoding of symbols affected by RBS.

3. A method according to claim 1, wherein  $N=6$ .

4. A method according to claim 1, wherein said transmitting step transmits signal segments having  $N$  symbols.

5. A method according to claim 1, wherein said initializing step initializes said modulo-N symbol counter in response to receipt of the first symbol of a subsequent signal segment that follows said initial signal segment.

6. A method according to claim 1, wherein said initializing step initializes said modulo-N symbol counter after receipt of a reference position symbol of said initial signal segment.

7. In a data communication system having a first device configured to transmit data to a second device, a method for compensating for digital impairments in a transmit signal, where said digital impairments arrive at said second device in a periodic manner based on a period of  $N$  symbols, said method comprising the steps of:

formatting a plurality of signal segments such that each of said signal segments is represented by an integer multiple of  $N$  symbols;

starting a first symbol counter at said first device upon transmission of a first symbol associated with one of said signal segments;

transmitting said signal segments from said first device to said second device;

initializing a second symbol counter at said second device after receipt of said first symbol by said second device;

utilizing compensating signal point constellations, in response to said second symbol counter, for symbols affected by digital impairments;

detecting the first symbol of one of said signal segments after loss of an initial symbol synchronization between said second device and said first device; and

resetting said second symbol counter in response to said detecting step.

8. A method according to claim 7, further comprising the step of determining at least one symbol position, relative to each of said signal segments, where a digital impairment was introduced, said determining step being responsive to said initializing step.

## 14

9. A method according to claim 7, wherein said digital impairment comprises robbed bit signaling (RBS).

10. A method according to claim 7, further comprising the step of selecting a plurality of optimized signal point constellations associated with different states of said second symbol counter, said selecting step being performed by said second device.

11. A method according to claim 10, further comprising the step of sending information indicative of said optimized signal point constellations from said second device to said first device.

12. A method according to claim 7, wherein said second symbol counter comprises a modulo-N symbol counter.

13. A method according to claim 7, wherein:

said first symbol is associated with an initial signal segment; and

said initializing step initializes said second symbol counter in response to receipt of a first symbol of a subsequent signal segment that follows said initial signal segment.

14. A synchronization method for a communication device connected to a communication network employing robbed bit signaling (RBS), such that symbols affected by RBS arrive at the communication device in a periodic manner based on a period of  $N$  symbols, the method comprising the steps of:

receiving a plurality of signal segments at the communication device with each of the signal segments being represented by an integer multiple of  $N$  symbols;

synchronizing the communication device to the integer multiple of  $N$  symbols;

initializing a modulo-N symbol counter in the communication device in response to receipt of an initial signal segment by the communication device, the modulo-N symbol counter being synchronous to a symbol count associated with a signal segment of the plurality of signal segments;

detecting the effect of RBS in a received signal segment of the plurality of signal segments;

determining an at least one symbol position, relative to the received signal segment, where RBS was employed by the communication network;

identifying a reference-position symbol of one of the signal segments after loss of an initial symbol synchronization with the communication network; and

resetting the modulo-N symbol counter in response to the identifying step.

15. The method of claim 14, further comprising the step of deriving, for each of the at least one symbol position, a compensating signal point constellation for use during subsequent encoding and decoding of symbols affected by RBS.

16. The method of claim 14, wherein  $N=6$ .

17. The method of claim 14, wherein the initializing step initializes the modulo-N symbol counter in response to receipt of the first symbol of a subsequent signal segment that follows the initial signal segment.

18. The method of claim 14, wherein the initializing step initializes the modulo-N symbol counter after receipt of a reference-position symbol of the initial signal segment.