



US00D980781S

(12) **United States Design Patent**
Fengfeng

(10) **Patent No.:** **US D980,781 S**

(45) **Date of Patent:** **** Mar. 14, 2023**

(54) **AUTOMOBILE PASSENGER GRAB HANDLE**

(71) Applicant: **Huang Fengfeng**, Nanning (CN)

(72) Inventor: **Huang Fengfeng**, Nanning (CN)

(**) Term: **15 Years**

(21) Appl. No.: **29/811,513**

(22) Filed: **Oct. 14, 2021**

D688,020	S	*	8/2013	Workman	D34/27
D708,501	S	*	7/2014	Stefnitz	B25G 1/04
						D8/107
D738,569	S	*	9/2015	Saide	D27/165
D818,883	S	*	5/2018	Lundh	D12/133
D834,480	S	*	11/2018	Manzoni	D12/195
D842,675	S	*	3/2019	Raymond	D8/303
D856,448	S	*	8/2019	Chuang	D21/694
D881,672	S	*	4/2020	Christodoulou	D8/302
D929,205	S	*	8/2021	Lessard	D8/303
D934,654	S	*	11/2021	Alvarez	D8/303
2006/0208515	A1	*	9/2006	Murphy	B65D 33/02
						294/137
2010/0115809	A1	*	5/2010	Pacheco	G09F 21/049
						40/318
2013/0180084	A1	*	7/2013	Edson	A45B 9/02
						16/430

Related U.S. Application Data

(63) Continuation-in-part of application No. 29/692,844, filed on May 29, 2019, now abandoned.

(51) **LOC (14) Cl.** **12-16**

(52) **U.S. Cl.**

USPC **D12/400; D8/303**

(58) **Field of Classification Search**

USPC D8/300, 301, 302, 303, 315, 316, 318, D8/319, 320, 350, 107, 356; D12/187, D12/188, 189, 190, 193, 195, 196, 414, D12/114, 178, 184, 400, 406, 412, 169, D12/167, 128-133; D21/662, 672, 682, D21/684, 694; D27/101, 148, 162, 163, D27/165, 167, 171, 172, 182, 183, 188, D27/192, 193, 194; D34/15, 27

CPC .. A45B 9/02; B65D 33/02; B25G 1/04; A45F 5/1026; G09F 21/049

See application file for complete search history.

(56) **References Cited**

U.S. PATENT DOCUMENTS

D339,892	S	*	9/1993	Wu	D34/15
D466,786	S	*	12/2002	Bourgeois	D8/107
D534,051	S	*	12/2006	Jackson	D8/107
D535,544	S	*	1/2007	DeBraul	D8/303
D547,159	S	*	7/2007	Porth	D8/303
D621,121	S	*	8/2010	Maatz	D34/27
D654,775	S	*	2/2012	Higashi	D8/303

* cited by examiner

Primary Examiner — Kevin K Rudzinski

Assistant Examiner — Jerry Shiuan-Hua Hsu

(74) *Attorney, Agent, or Firm* — Pasadena Legal Group; Norman R. Van Treeck

(57) **CLAIM**

The ornamental design of an automobile passenger grab handle, as shown and described.

DESCRIPTION

FIG. 1 is a front perspective view of an automobile passenger grab handle according to my new design;

FIG. 2 is a top view thereof;

FIG. 3 is a bottom view thereof;

FIG. 4 is a left side view thereof;

FIG. 5 is a right side view thereof;

FIG. 6 is a front end view thereof; and,

FIG. 7 is a rear end view thereof.

The broken lines shown in the drawings depict portions of the automobile passenger grab handle which form no part of the claimed design.

1 Claim, 7 Drawing Sheets

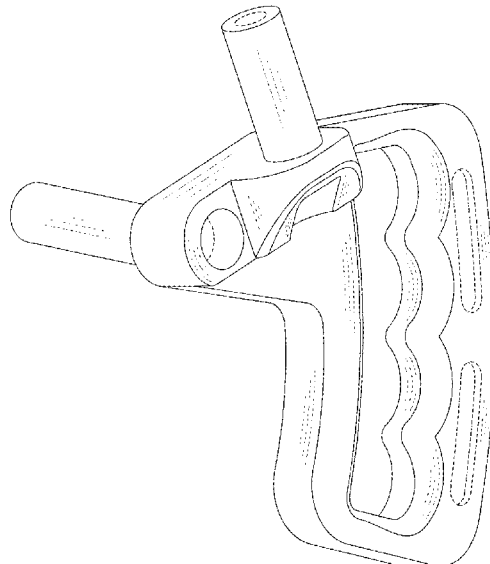

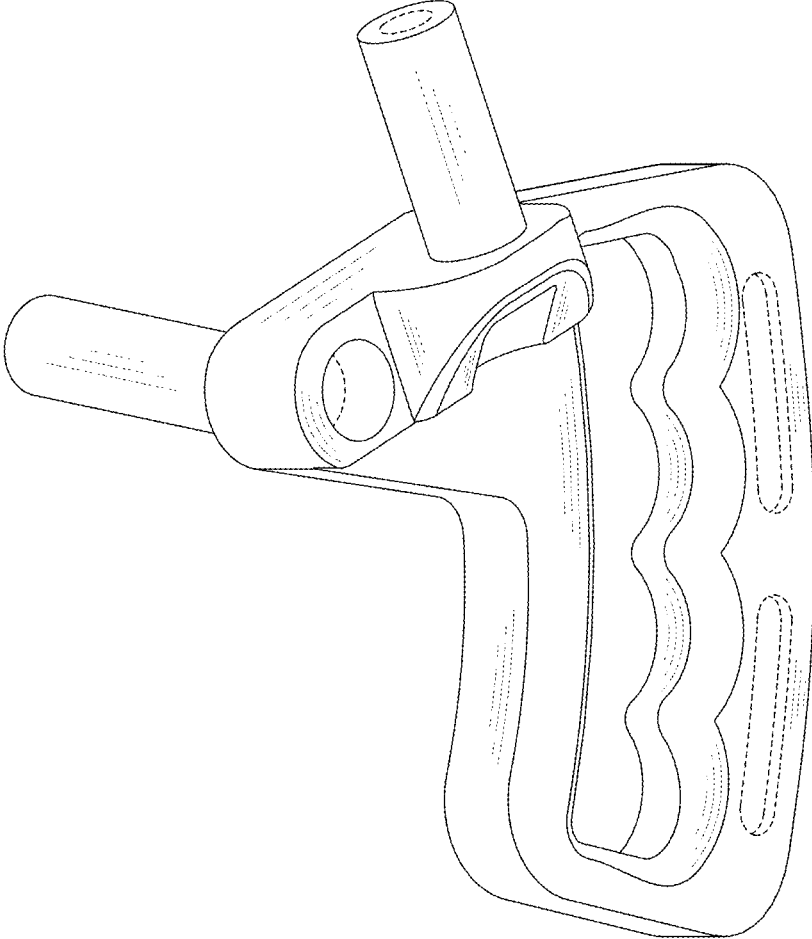

FIG. 1

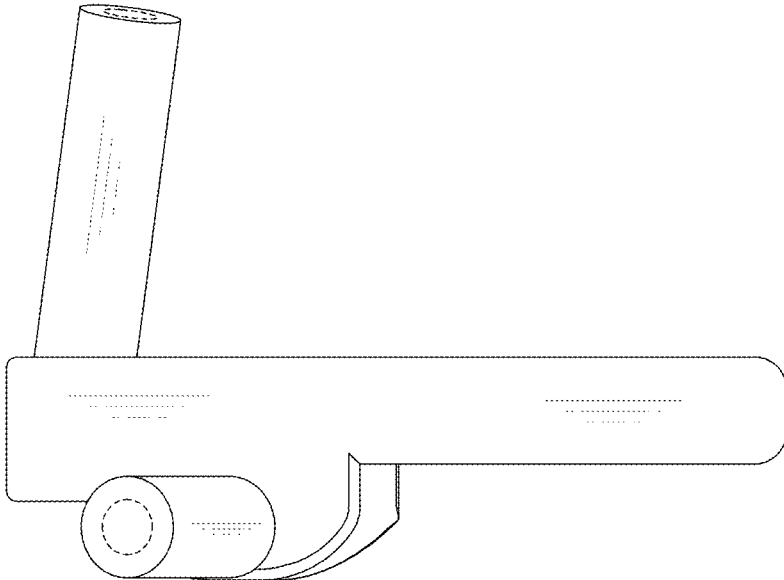

FIG. 2

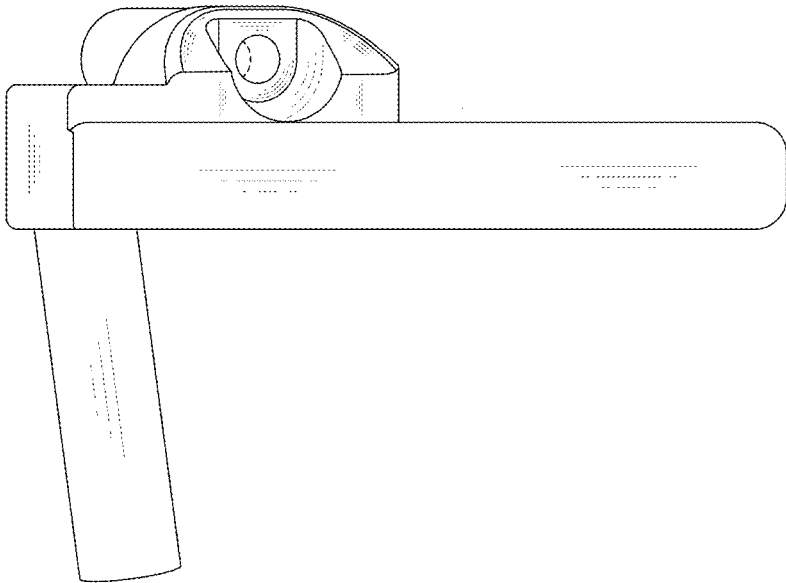

FIG. 3

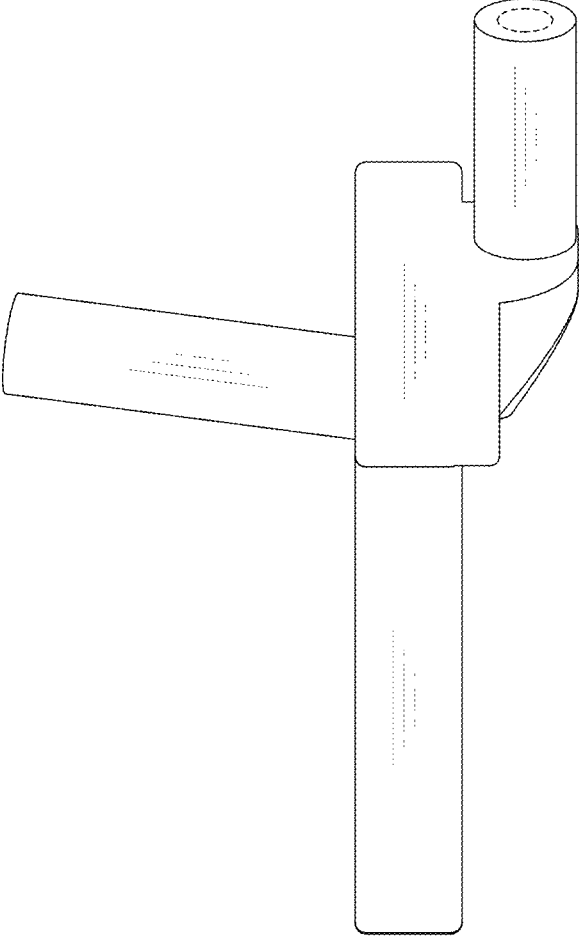

FIG. 4

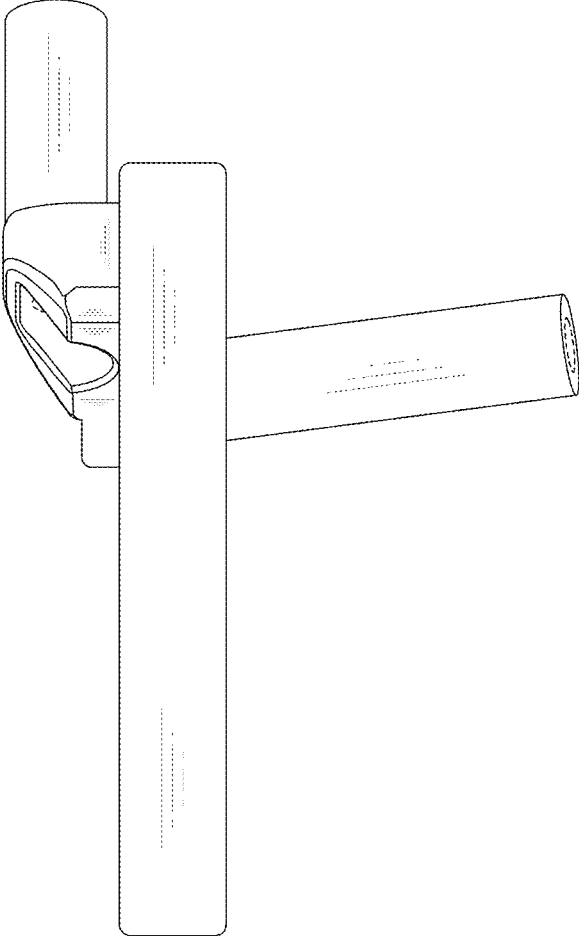

FIG. 5

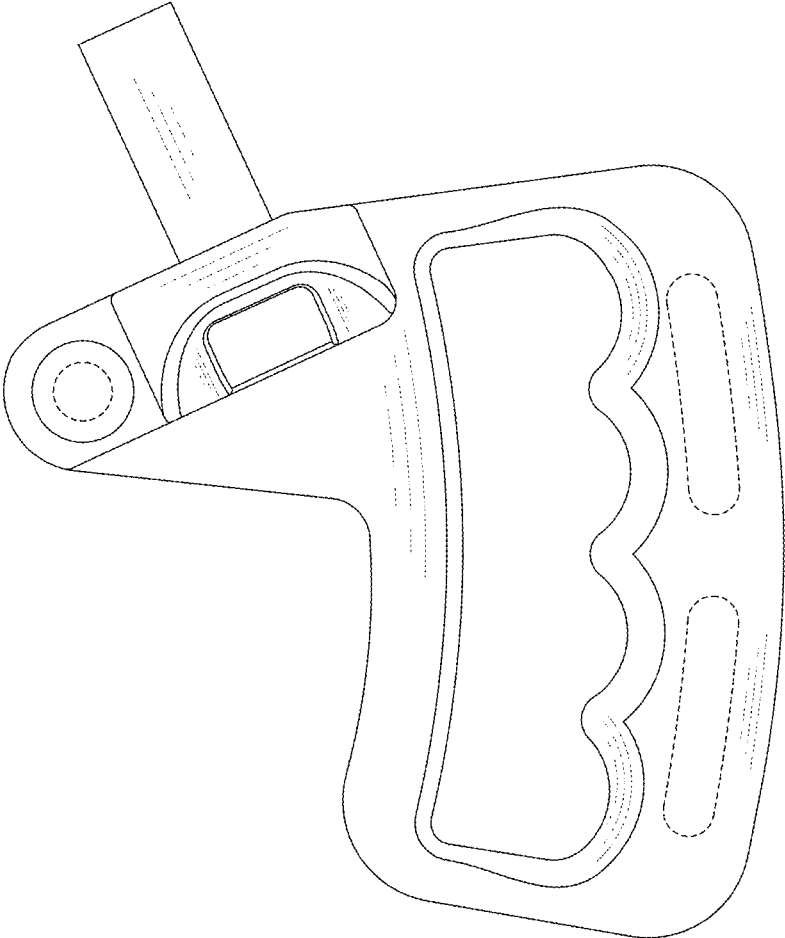

FIG. 6

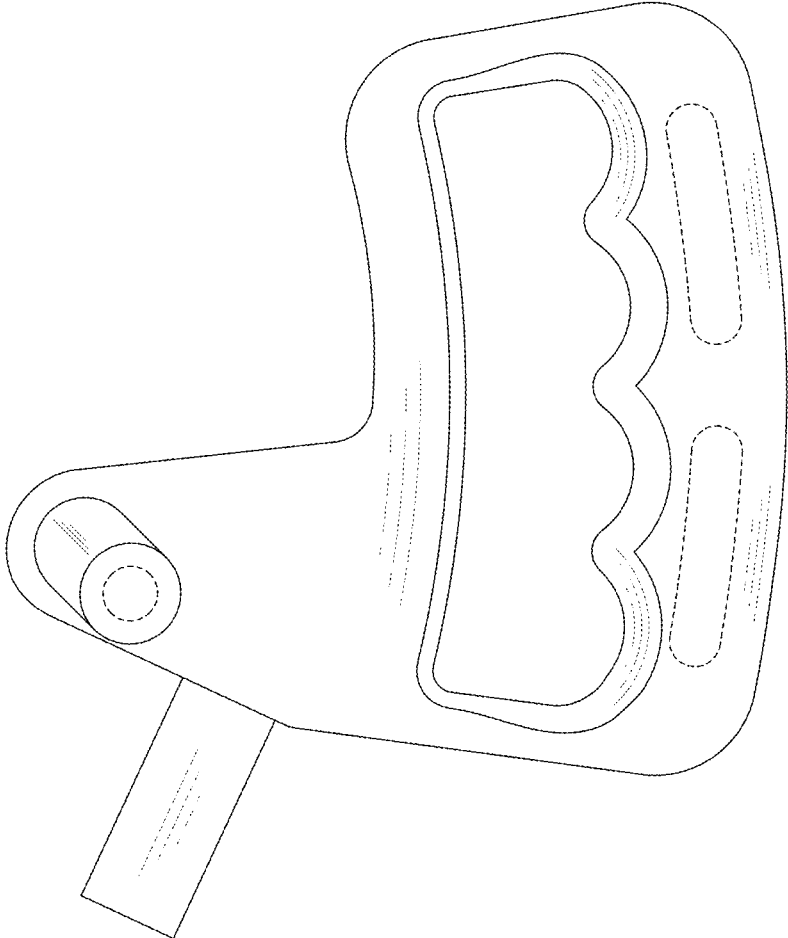

FIG. 7