

[54] **APPARATUS FOR CONVEYING AND DEGASSING A VISCOUS LIQUID**

[76] Inventors: **Theo Sauer; Anton Riedel**, both of Perutz Photowerke, Kistlerhofstr. 75, D-8000 Munich 25, Germany

[22] Filed: **Sept. 10, 1970**

[21] Appl. No.: **71,120**

[30] **Foreign Application Priority Data**

Sept. 13, 1968 Germany.....P 19 46 563.5

[52] U.S. Cl.....**55/164, 55/192**

[51] Int. Cl.....**B01d 19/00**

[58] Field of Search.....55/15, 21, 160, 164, 192, 193, 55/199, 277, 201

[56] **References Cited**

UNITED STATES PATENTS

3,495,382 2/1970 Adamik.....55/166
3,284,991 11/1966 Ploegr et al.55/15

3,018,843 1/1962 Mercier.....55/199 X
3,464,187 9/1969 Westerlund.....55/199
3,517,487 6/1970 Burnham, Sr.55/192
2,966,230 12/1960 Cervinka.....55/193
3,154,465 10/1964 Degnen.....55/15 X

Primary Examiner—Reuben Friedman

Assistant Examiner—R. W. Burks

Attorney—Connolly and Hutz

[57] **ABSTRACT**

An apparatus for conveying and degassing a viscous liquid from a storage tank to a mold shell by way of an intermediate container disposed higher than the mold shell including a further container between the intermediate container and the storage tank. At least one ultrasonic generator is provided as well as an automatic inlet valve which opens during ultrasound. An automatic outlet valve is also disposed between the intermediate and further containers to open when the further containers is under atmospheric pressure.

10 Claims, 2 Drawing Figures

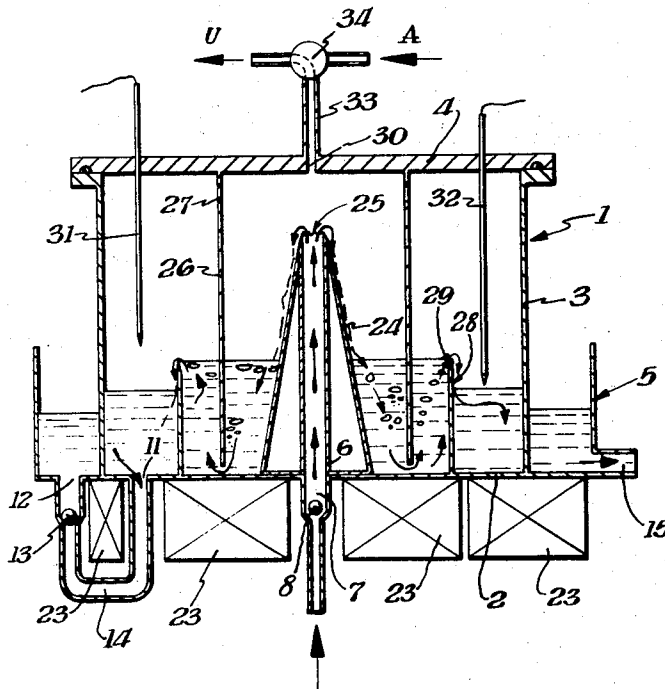

Fig. 1.

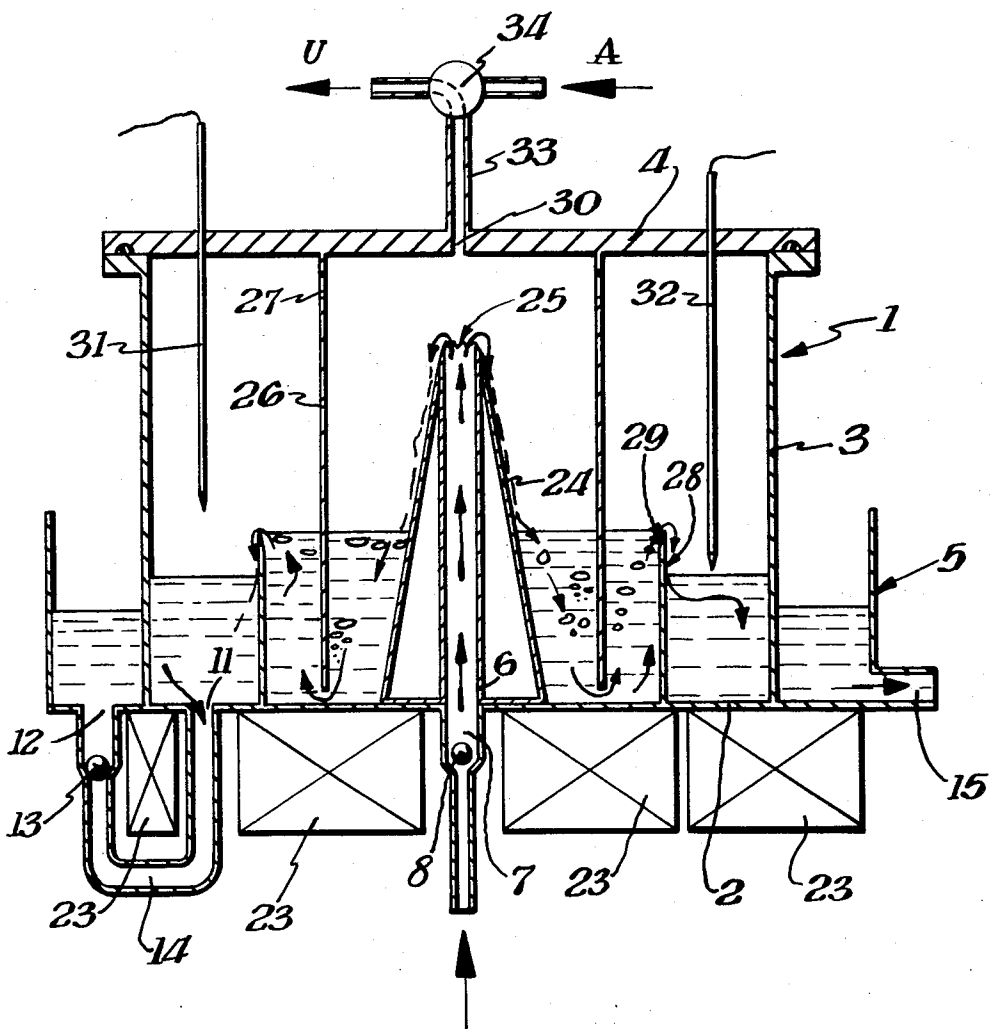
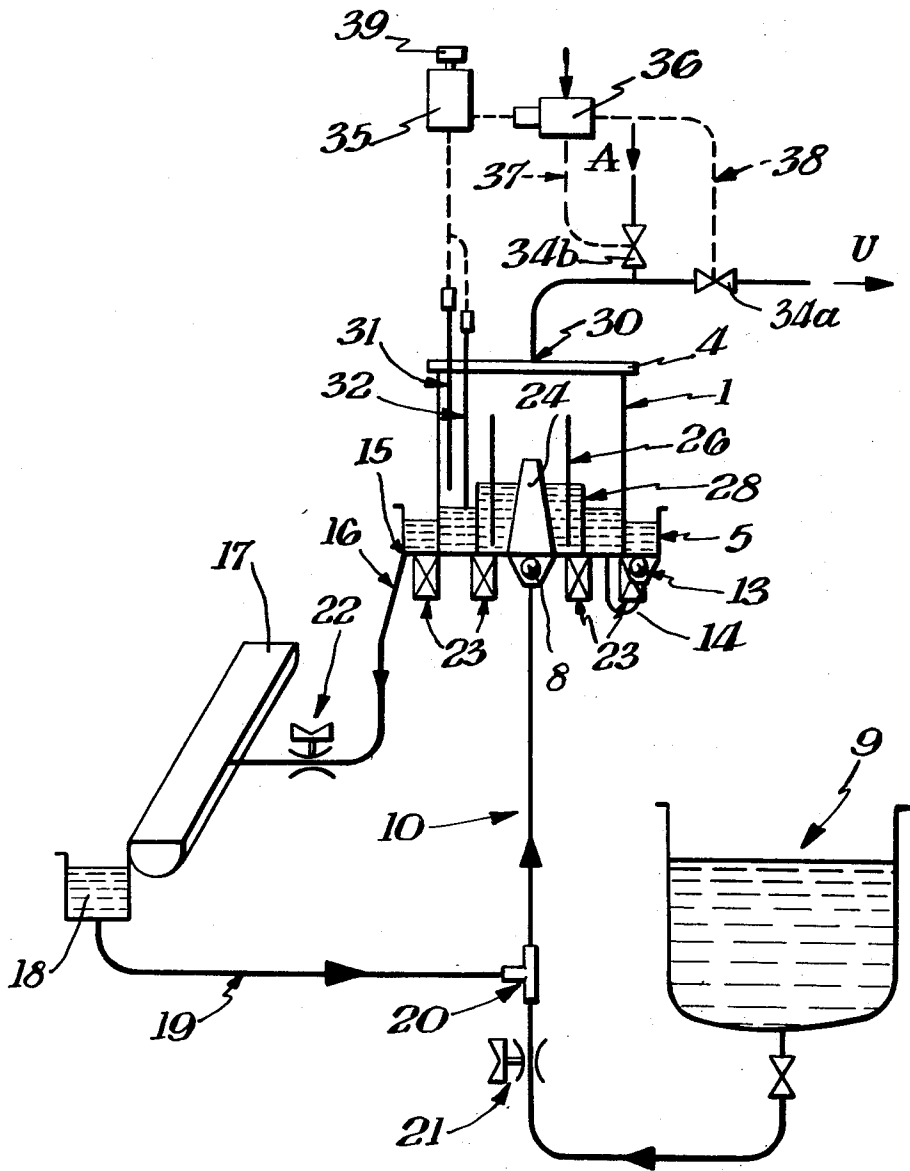

Fig. 2.



APPARATUS FOR CONVEYING AND DEGASSING A VISCOUS LIQUID

BACKGROUND OF INVENTION

The invention relates to an apparatus for conveying a viscous liquid, particularly an emulsion or the like, from a storage container or storage tank, to an intermediate container situated higher as compared to a mold shell, and for their degassing.

Devices for the conveying of a viscous liquid and devices for the degassing of the liquid frequently serve for the preparation of a liquid as free as possible of inclusions of gas or hence bubbling, at or near the location of their use or further processing. Of particular importance of the convection of a liquid while avoiding bubble formation and similarly the extensive elimination by degassing of bubbles locked in the liquid in all instances wherein the liquid is utilized for the separation of a film, a foil or coating of bases in a relatively moderate thickness, e.g., by brushing or pouring, and a homogeneous foil or coating is required as for example in the photochemical industry.

In order to achieve a convection of the viscous liquids with the avoidance of bubble formation or gas locks, it is already known to use hose compression pumps instead of other pumps as the conveying means, and subsequent thereto to provide a degassing arrangement and a container open to the atmosphere above the place of utilization (such as a mold shell) in order to remove the bubbles contained in the liquid and also resulting with this convection of the liquid; something which succeeds only more or less incompletely, however. Usually such gas locks or bubbles occur because of the lack of ideal construction and laying of the tubing, whereby air pockets therein are unavoidable. Eventually these air pockets disintegrate during the operation, and they consequently contribute to a bubble formation in the liquid. Should, in such equipment, different liquids or charges be conducted in sequence and frequently consequently require a cleaning after the preceding emptying, there results thereby a particularly high degree of formation and occurrence of bubbles. Quite apparently the bubble formation is also prompted by the separation or disintegration of the liquid by the conveying elements of a pump, hence also by a hose compression pump. With constantly increasing demands on the quality of films, foils, and coatings, it has been shown that even in using hose compression pumps for the convection and in using intermediate containers for the degassing, a liquid sufficiently free of gas locks or of bubbles cannot be prepared.

For the degassing, and hence for the removal of bubbles from a liquid, there are indeed known arrangements operating with vacuum, such as downdraft or thin layer evaporators, but which due to their expensive construction are used only for continuous application over a long period of time and throughput of large amounts.

SUMMARY OF INVENTION

The object of this invention is to provide an apparatus for the conveying of a viscous liquid, particularly of an emulsion or the like, from a storage tank to an intermediate container situated higher as compared to a mold shell and their degassing which enables a bubble-avoiding convection as well as a particularly in-

tensive degassing of the liquid. In this connection, the apparatus is particularly advantageous because it is economical in construction and in operation as well as providing the possibility of simple cleaning with small losses of liquid.

In accordance with this invention, the problem is solved in that in the conveying route between the storage tank and the intermediate container, there is arranged a further container closed off from the surrounding atmospheric pressure. This further container is affected by means of a vacuum producer such as a vacuum pump with vacuum or subatmospheric pressure and interchangeably with atmospheric pressure and is provided with at least one ultrasonic generator having an automatic valve (such as a ball valve) opening from the storage tank. An additional automatic valve (such as a ball valve) opens in the container during atmospheric pressure at the outlet opening to the intermediate container or the like. With this construction the vacuum in the container serves simultaneously for the convection of the liquid into the container and also for the degassing of the liquid in the container. Thus an original cause for the formation of bubbles is eliminated by the avoidance of any cross-sectional changes in the liquid flow or a "distribution" of the liquid. At the same time it appears with this construction that only by the combined effect on the liquid in the container of vacuum and ultrasonic vibrations is there given a particularly high degree of effectiveness in the degassing. The apparatus is of extremely simple construction, particularly also because of the dual functions previously carried out separately, namely conveying and degassing. It is also advantageous that the device is free of mechanically moving parts which could be subject to wear.

In accordance with a further aspect of the invention there may be provided in the container, capacity indicators by which, depending on a minimum and a maximum capacity, two valves or a three-way valve are controlled by an energizer or the like in such a manner that the container is affected upon reaching the minimum capacity with vacuum and upon reaching the maximum capacity with atmospheric pressure, whereby an automatic manner of operation of the device is achieved.

According to one design of the invention, there are arranged in the container between its intake opening from the storage tank and its outlet opening to the intermediate container or the like at least one wall extending downwardly dipped into the liquid from above and a wall extending from the bottom upwards in such a manner that the flow direction of the liquid is conducted through under the dipped-in wall and away over the wall extending upwards. As a consequence of this construction, the liquid is delivered in a very thin layer over the upper edge of the wall extending upwards, whereby, even by the deflection of the liquid, the emerging of existing bubbles is highly promoted. Moreover, the liquid must move in the direction toward the bottom of the container in order to be able to flow through under the dipped-in wall, so that not only are the ultrasound fluctuations on it intensified and eventually small bubbles act cumulatively to larger ones but also the bubbles, as a result of stronger upward force, experienced a greater experience in the direction

toward the liquid level. Of course, also the emergence of the bubbles from the liquid is strongly supported during overflowing over the upper edge of the wall extending upwards.

In addition, the effect of one or more walls extending upwards from the bottom of the container is intensified by a novel further development wherein at least one or several walls extending upwards have a sharp-edged upper edge similar to a cutter. Thereby and in connection with the ultrasound fluctuations, the bubbles are particularly effectively brought to emergence and practically to a bursting open.

A further characteristic of the invention is that at least one of the walls is arranged concentrically to the inlet opening of the container, whereby, especially with a concentric arrangement of all walls, all flow lines of the liquid within the container are kept approximately equally long and consequently are subjected to an even degassing effect.

According to another novel development, the inner wall placed directly about the inlet opening, extended by means of a tube, and extending upwards from the bottom of the container is constructed to expand downwards in a truncated cone shape, so that the liquid reaching the container is spread out into a thin layer on a surface increasing in spread, and consequently facilitating the emergence of the bubbles locked therein.

A particularly uniform distribution of the liquid is achieved in that the edge, formed from the free end of the tube and the upper border of the truncated-cone-shaped inner wall, proceeds in a wave-like manner.

A further development according to the invention consists of the outer surface of the truncated-cone-shaped inner wall having an approximately horizontally preceding surface structure (i.e., being provided with horizontally disposed surfaces or grooves in its surface), whereby a uniform spread of the liquid on the outer surface of the truncated-cone-shaped inner wall is assured to a particularly high degree and the formation of the so-called flow spouts is eliminated.

Finally, it is suggested according to the invention that the intermediate container or the like, especially with a circular-cylindrical construction of the container and of the walls arranged therein, be joined directly to the outer wall of the container, whereby not only is one wall of the intermediate container eliminated and the latter may be affected, simultaneously with the container, with ultrasound fluctuations but also a particularly space-saving arrangement is met.

THE DRAWINGS

FIG. 1 shows an apparatus for conveying and degassing a viscous liquid and a container, in cross-sectional elevation view; and

FIG. 2 shows schematically an apparatus similar to that of FIG. 1 in smaller scale within coating equipment.

DETAILED DESCRIPTION

According to FIGS. 1 and 2, an apparatus for the conveying and degassing consists of a circular cylindrical container 1 with a bottom 2, jacket 3 and cover 4 to which is joined outwards an intermediate container 5 in such a manner that jacket 3 at the same time represents a side wall of the intermediate container 5.

In the center of the bottom 2 there is provided an inlet opening 7, which projects upwards by a tube 6, with a ball valve therein. Valve 8 permits communication between tube 6 and a tube conduit 10 leading from a storage tank 9.

In the planar or level bottom 2 of container 1 and of intermediate container 5 there are arranged in container 1 a drain opening 11 and in the bottom of intermediate container 5 an intake opening 12 which are connected together by a short pipe line 14, using a ball valve 13, in such a manner that the liquid in container 1 and in the intermediate container 5 is set equally high corresponding to the communicating principle. As shown in FIG. 2 from the outlet opening 15 of the intermediate container 5, a sloping pipe line 16 leads to a mold shell 17. An overflow tank 18 situated thereon is connected by way of a pipe line 19 by means of a T-piece 20 with the pipe line 10 so that the liquid not utilized in mold shell 17 may be prepared again. Furthermore, in pipe line 10, between the T-piece 20 and the storage tank 9, and on the downstream end of pipe line 16, there are provided a squeezing or pressure valve 21 or 22 each.

At bottom 2 of container 1 and at the bottom of the intermediate container 5 there are arranged ultrasonic generators 23, whereby a frequency of 20 kilocycles per second, for example, may be received.

In container 1, directly about the inlet opening 7 extended by means of pipe 6, there is arranged a truncated-cone shaped inner wall 24, which extends from bottom 2 upwards and whose upper edge 25, common with pipe 6, is approximately wave shaped or undulated. The outer surface of the truncated-cone shaped inner wall 24 has an approximately planar or horizontal surface structure.

Concentric with the center axis of container 1 there is provided a cylindrical wall 26 projecting or dipped from above into the liquid. Wall 26 is mounted and held at cover 4 and is provided with perforations 27 near cover 4 serving for pressure equalization on both sides of wall 26. An additional wall 28 extends from bottom 2 upwards; the upper free edge 29 of the wall 28 being made to have a sharp edge, similar to a cutter.

In the center of lid 4 there is an opening 30 for affecting the inner space of container 1 with a vacuum or atmospheric pressure. In addition, capacity indicators 31 and 32 are mounted on cover 4.

To opening 30 is joined pipe conduit 33 which leads to a three-way valve 34 or by way of a T-piece to valves 34a and 34b.

According to FIG. 1 the three-way valve 34 is controlled and activated, in a manner not further illustrated, by means of capacity indicators 31 and 32 in such a manner that the inner space of container 1 is affected by vacuum (arrow U) produced by a vacuum producer, a vacuum pump, or the like, as soon as the capacity indicator 32 detects a minimum level of liquid. As soon as a maximum level and consequently the capacity indicator 31 is reached, there occurs an activation of the three-way valve 34 so that the inner space of container 1 is affected with atmospheric pressure in the direction of arrow A.

According to FIG. 2, the same process is effected in that by the showing of the capacity indicators 31 and 32, an energizer 35 transforms the received impulses by way of a control valve 36 and compressed air conduit

37 or 38 to an opening of the valve 34a for the production of vacuum (arrow U) or to an opening of valve 34b for purposes of building up atmospheric pressure (arrow A). For measuring the amount of liquid passed through container 1 in such manner, a counter 39 may be provided at energizer or intensifier 35.

In an earlier described construction of the apparatus for conveying and degassing a viscous liquid of a viscosity of 2 to 50 cp, there occurs the following operation:

With the indication of a minimum level by means of the capacity indicator 32, the inner space of container 1 is affected by vacuum in an already described manner so that the liquid contained in storage tank 9 is pressed into container 1 by the greater atmospheric pressure existing there through pipe line 10 and the then opened ball valve 8. In this connection, the ball valve 13 is closed as a result of atmospheric pressure on the liquid in the intermediate container 5. After passing pipe 6, the liquid, evenly divided by the wave-shaped edge 25, reaches the truncated-cone-shaped inner wall 24, where as a result of the increasing outer surface and of the horizontally proceeding surface of the truncated-cone-shaped inner wall 24, it is spread out to a thin layer so that already with overflowing of edge 25 and of the inner wall 24, a strong degassing, an emergence of bubbles, is achieved under the influence of vacuum and of ultrasonic frequencies. Upon achieving the level of liquid in the space between the truncated-cone-shaped inner wall 24 and the wall 26 extending into the liquid from above, the liquid begins to move in the direction of bottom 2 in order to flow through under wall 26 in the endeavoring of an equalization of the liquid level in the space between the dipped-in wall 26 and the wall 28 extending upwards. In nearing bottom 2, the ultrasonic fluctuations to a high degree affect the liquid so that very small bubbles accumulate into larger ones. At the same time, however, the driving force of the bubbles increases so that they experience an acceleration in the direction of the liquid level and emerge from the liquid with vehemence. Thereupon, the liquid finally arrives over the sharp upper edge or an edge shaped similar to a cutter of wall 28, whereby there is again formed a thin layer and because of the deflection, favors an emergence of still existing bubbles.

This process continues until the liquid level in the chamber between jacket 3 and wall 28 reaches the capacity indicator 31. By its operation, the vacuum is now lifted and indeed by the activation of the three-way valve 34 according to FIG. 1 or by operation of the energizer 35, of control valve 36 and valves 34a and 34b, whereby first the ball valve 8 is closed and with delay the ball valve 13 is opened. This makes it possible for the liquid to reach the intermediate container 5 through outlet opening 11 and the pipe line 14 where it is subjected to further ultrasonic fluctuations until it is drawn off finally to the mold shell 17. As soon as the liquid level has been lowered to such an extent that the capacity indicator 32 is tripped, a new conveying process begins.

In the above-described manner of operation it is still of importance that container 1 and walls 24, 26, and 28 are arranged concentric to each other whereby all flow lines are kept about equally long and are uniformly spread out from edge 25 up to edge 29.

By way of FIG. 2 the advantage should again be pointed out that is offered by the novel apparatus also with respect to the expenditure pertaining to the apparatus. Previously, for equipment of the general type shown, two hose press pumps were required, and indeed both in the pipe line 19 as well as in the part before the T-piece 20 of pipe line 10, which for their input have equally contributed to the forming of bubbles.

Of course the concept of the invention encompasses numerous possible designs adapted to individual purposes, as for example for the control of the filling and emptying process. However, the basic concepts of the invention are concerned with a single device to convey a liquid by means of a vacuum and under ultrasonic by repeated and constant spreading out as well as by means of further described steps simultaneously to degas the liquid, whereby the arrangement additionally allows a frequent resetting for different liquids.

What is claimed is:

1. In an apparatus for treating photographic suspensions wherein a viscous liquid is conveyed from a storage tank to a mold shell by way of an intermediate container placed higher than the mold shell and for degassing this liquid, the improvement comprising a further container being between the storage tank and the intermediate container, said further container being closed off from the surrounding atmospheric pressure, pressure means for selectively producing alternatively a subatmospheric pressure or an atmospheric pressure in said further container, at least one ultrasonic generator, said further container having an automatic inlet valve at the intake from the storage tank, said intake valve opening during subatmospheric pressure in the further container, an automatic outlet valve in the container at the outlet to the intermediate container, said outlet valve opening during atmospheric pressure in the further container, a wall downwardly projecting into the liquid from above and an upwardly extending wall being disposed between said inlet opening and outlet opening, said walls being arranged in such a manner that the liquid is conducted over the upwardly extending wall and then under the downwardly extending wall, and the upwardly extending wall being in the form of a truncated-cone-shaped conduit located directly over and communicating with the inlet opening of said further container to spread the inflowing liquid into a thin layer as it flows over said truncated-cone-shaped conduit with the cone-shaped wall of the conduit being at the bottom of the cylindrical container.

2. Apparatus of claim 1 characterized in that capacity indicators are provided in said container for detecting predetermined minimum and maximum capacities therein, valve means actuated by said indicators and dependent on said minimum and said maximum capacities in the container to cause a subatmospheric pressure upon reaching the minimum capacity and atmospheric pressure upon reaching the maximum capacity.

3. Apparatus of claim 1, characterized in that said upwardly extending wall has a sharp cutter-like edge at its upper edge.

4. Apparatus of claim 1, characterized in that the upper seam of said truncated-cone-shaped wall is of approximately a wave-like construction.

7

8

5. Apparatus of claim 1, characterized in that the outer surface of said truncated-cone-shaped wall has an approximately planar surface structure.

6. Apparatus of claim 5, characterized in that the intermediate container is of cylindrical construction with its inner wall being the outer wall of said further container.

7. Apparatus of claim 2, characterized in that said valve means comprises energizer means and a pair of valves and said energizer means selectively transforming the received impulses from said indicators to one of said pair of valves for the selective activation of said pair of valves.

8. Apparatus of claim 2, characterized in that said valve means includes a three-way valve.

9. Apparatus of claim 1, characterized in a further cylindrical wall disposed concentric to and around said truncated-cone-shaped wall, and said downwardly extending wall being concentric with and between said upwardly extending walls.

10. Apparatus of claim 1, characterized in that the intermediate container is of cylindrical construction with its inner wall being the outer wall of said further container.

* * * * *

15

20

25

30

35

40

45

50

55

60

65