

March 19, 1968

W. R. JUDD
TOROIDAL TRANSFORMER CONSTRUCTION AND METHOD
OF CONSTRUCTING SAME

3,374,452

Filed Sept. 26, 1966

2 Sheets-Sheet 1

FIG. 1

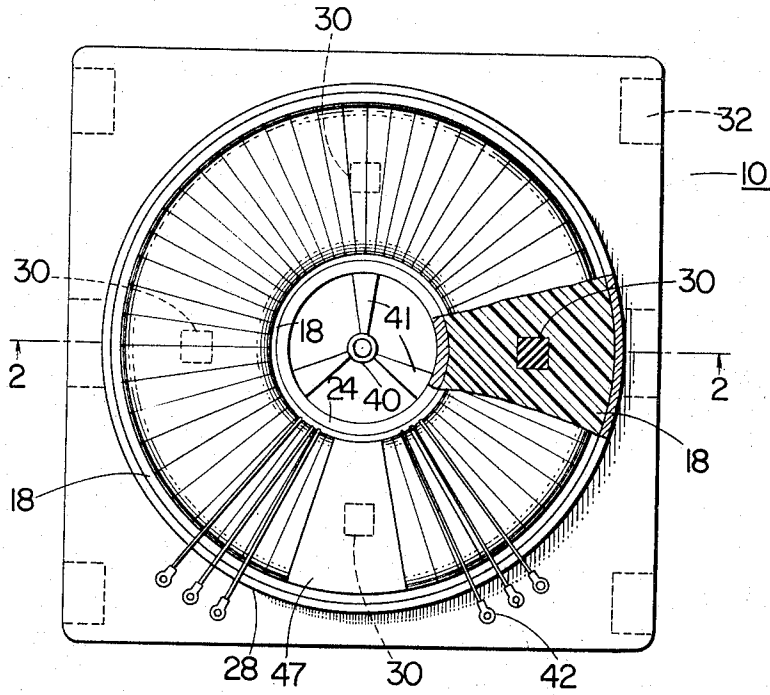
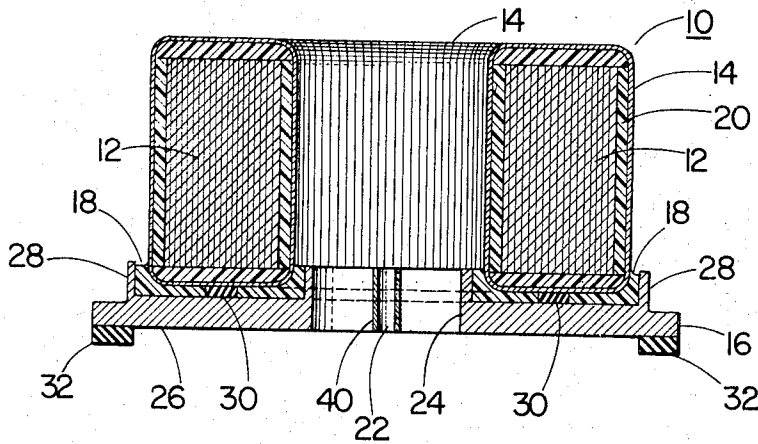

FIG. 2



INVENTOR
Winston R. Judd,
BY *A. Sibney & Co.*
ATTORNEY

1

3,374,452

TOROIDAL TRANSFORMER CONSTRUCTION AND METHOD OF CONSTRUCTING SAME

Winston R. Judd, Pittsfield, Mass., assignor to General Electric Company, a corporation of New York
 Continuation-in-part of application Ser. No. 386,838, Aug. 3, 1964. This application Sept. 26, 1966, Ser. No. 582,024

8 Claims. (Cl. 336-60)

This is a continuation-in-part of application Ser. No. 386,838 filed Aug. 3, 1964 now abandoned.

This invention relates to transformer structures and more particularly to a toroidal transformer construction such as finds great utility in variable transformers.

As is well known by those skilled in the art, variable transformers generally include a single winding wound on a magnetic core member, the winding being energized by a predetermined alternating voltage. A sliding tap is provided sliding along the surface of the single winding and connected to an output terminal. The sliding tap picks off a voltage from the winding which varies from zero up to the predetermined voltage applied to the winding. An example of this type of variable transformer is disclosed for example in Patent No. 2,009,013. These transformers find use in various types of motor controls, power supplies and many other types of equipment.

In most variable transformers the core and coil unit are attached to a base member, the base member providing the means for mounting the variable transformer to the appropriate equipment. The attachment of the coil and core unit is usually made by means of a clamping device or a similar member which extends through the central opening of the core and coil unit. These attaching means are generally secured either to the upper surface of the coil of the core and coil unit or are fastened to the coil within the central opening. While all of these various attaching means provide the desired mechanical strength they tend to obstruct the transfer of heat from the variable transformers. Since the load current ratings of variable transformers depends upon the amount of heat maintained within the transformers, the prior art structures prevent the full use of the possible current-carrying capabilities of prior art variable transformers. If more of the generated heat could be removed from the core and coil unit of the transformer it would be possible to operate such variable transformer at higher load current ratings.

It has recently been discovered that a novel toroidal transformer structure may be made which promotes heat transfer from the core and coil area, both from the lower end of the core and coil by conduction and from the central opening of the core and coil by means of convection. By this type of improved construction, it is possible to substantially increase the load current ratings of variable transformers.

Therefore, it is one object of this invention to provide an improved toroidal transformer construction.

Another object of this invention is to provide a toroidal construction which promotes the transfer of heat from the core and coil unit by conduction, convection, and radiation.

A further object of the invention is to provide a novel toroidal transformer construction which does not require clamps obstructing the central opening of the core and coil unit to secure the core and coil unit to the base.

A still further object of the invention is to provide a new and improved method of constructing a toroidal transformer.

In carrying out this invention in one form, a toroidal transformer is provided comprising a magnetic core member having a single winding wound about the core mem-

2

ber. A base member is provided having a central opening with a ring-shaped cavity formed about such central opening. The core and coil unit is placed within the ring cavity mounted on a plurality of spacers. A resinous material in liquid form is poured into the cavity, which on curing, cements the core and coil unit firmly to the base member.

The invention which is sought to be protected in this application will be clearly pointed out and distinctly claimed in the claims appended hereto. However, it is believed that this invention and the manner in which its various objects and advantages are obtained, as well as other objects and advantages thereof, will be more clearly understood by reference to the following detailed description, especially when considered in the light of the accompanying drawings, in which:

FIGURE 1 is a top view of a preferred form of the toroidal transformer construction of this invention;

FIGURE 2 is a sectional view taken along the lines 2-2 of FIGURE 1; and

FIGURE 3 is an exploded perspective view of a transformer embodying this invention.

Referring now to the drawings, in which like numerals are used to indicate like parts throughout the various views thereof, there is shown a preferred form of the novel toroidal transformer construction of this invention. As shown in FIGURES 1 and 2, the toroidal transformer 10 comprises a toroidal magnetic core member 12 about which is wound a single winding 14. The core and coil unit is mounted on a base member 16 and is firmly secured to the base by a resinous material 18.

As will be understood the magnetic core 12 of the toroidal transformer 10 comprises a spirally wound strip of transformer steel which is wound in toroidal form, in the manner indicated in the drawing. An insulating material, generally indicated as 20 in the drawing, is applied to the outer surface of core member 12 in any desired manner, as is well understood by those skilled in the art. The winding 14 is then wound about the insulation and the toroidal core 12 starting at one portion and then going substantially completely around the outer surface of the toroidal core member 12. A small portion 47 of the insulated core member is not covered by the winding and the opposite ends of the winding are connected to a source of alternating current by two of the plurality of leads identified by the numeral 42.

The rest of the leads 42 are connected to the winding at points intermediate its ends and each of the free ends of the leads are connected to terminal points 60-65 on terminal plate 43. When the transformer is assembled, this plate is located adjacent portion 47 of the core, and the terminal points 60-65 serve as junction points for various ones of the leads 42 and the leads from a conventional power source and the load.

The windings on the outer surface of the coil are stripped of insulation and form a track 45 for a slider member. This sliding member is mounted on the core and coil unit in a manner to allow the slider to move across the track from one end of the winding to the other to provide a variable voltage output. In the presently disclosed embodiment, this slider takes the form of a carbon brush 53 which is supported by an arm 52. Arm 52 is attached to and supported by the control plate 51, which may be an aluminum die casting.

When the transformer is assembled an electrically conductive path is completed from the point on track 45 contacted by the brush through the brush 53, arm 52, control plate 51, and assembly 44 to terminal point 66 on terminal plate 43.

Assembly 44 is illustrated in FIGURE 3 as including a housing supported on the terminal plate and a member 46 which is slidably supported in the housing. The mem-

ber 46 is made of a conductive material such as copper, carbon, or a combination of copper and carbon. Springs (not illustrated) bias the member 46 into electrical contact with the periphery of control plate 51 when the transformer is completely assembled.

The core and coil unit are mounted on a base member 16 which is useful both as a heat sink, and a means to attach the toroidal transformer to the equipment which will utilize the facilities of the transformer. As can be seen, particularly in FIGURES 2 and 3 of the drawings, the base member 16, which may be an aluminum die casting, is provided with a central aperture 22 which in general conforms to the central aperture of the toroidal transformer construction. About the central aperture 22 is provided an inner ring portion 24 which serves as a locating means, and dam for resinous material 18, and which extends above the main level 26 of the base 16. The inner ring member 24 may be formed integrally with the base member 16 or it may be mounted on the base member at a later time. An outer ring member 28 which also serves as a dam and locating means is provided concentric with the inner ring member 24 and is spaced therefrom a slightly greater distance than the thickness of the core and coil unit. In a similar manner the outer ring member 28 may be formed integral with the base member 16 or it may be a member added on to base member 16.

As shown, particularly in FIGURES 2 and 3, the base member 16 and the inner and outer ring portions 24 and 28, respectively, form therebetween a ring cavity into which the core and coil unit 12 and 14 may be placed. Spacer members, generally indicated as 30, are provided within the ring cavity to hold the core and coil unit above the level 26 of the base 16 in the manner particularly shown in FIGURE 2 of the drawing. After the core and coil unit are mounted in the ring cavity on top of spacers 30 a resinous material 18 is poured into the ring cavity completely surrounding the lower portion of the core and coil unit. The resinous material flows between each of the wires in winding 14 of the core and coil unit and establishes intimate contact therewith. The resinous material 18 may then be cured to firmly cement the core and coil unit to the base 16. The spacers must be dimensioned so that the resinous material can flow under the core and coil unit and into the winding 14.

If a resinous material having a high constant of thermal conductivity is selected for the resinous cement material 18, the resinous material will provide a path of high thermal conductivity from the winding 14 to the base member 16. In order to provide this desired thermal conductance a silica filled epoxy resin is preferred for the resinous material 18. The silica filled epoxy material will firmly bond to metallic base 16 and to the wires of winding 14 and will provide good dielectric strength to prevent any conduction from the winding 14 to the metal base 16. Of course, as is well understood, the silica filled epoxy material is a thermosetting resin and therefore must be raised to an elevated temperature in order to cure the resin 18. While a silica filled epoxy resin is preferred, various types of other resinous material could be used to provide the desired heat transfer and bonding.

When the present invention was actually reduced to practice, the silica filled epoxy material 18 was obtained from the Minnesota Mining and Manufacturing Co. of St. Paul, Minn. This material is manufactured and distributed commercially under the registered trademark of "Scotchcast" Brand Resin No. 281 by the aforementioned company. A published value of the thermal conductivity of this resin is 12×10^{-4} cal./sec./cm.²/° C./cm.

After the core and coil unit are bonded to the base, the remainder of the transformer is assembled. The control plate 51 is positioned over the core and coil unit with fastening rod 48 extending through the central bore of the coil. The control plate 51 is held in place by retaining means that, in the illustrated embodiment includes collar 40 which is held in the central aperture 22 of the base by webs 41.

Rod 48 is held in assembled relation with collar 40 by spring clips 50 which are inserted in circumferential grooves 55 near the end of the rod and bear against the washers 49. These washers 49 in turn bear against the faces of collar 40 with the result that control plate 51 may be spaced away from the adjacent end of the core and coil unit after the transformer is assembled.

In order to facilitate connection of the transformer to a power source and load, terminal plate 43 is provided. This plate is provided with a plurality of terminal points to which leads 42 are attached by conventional means, such as binding posts. The terminal plate 43 is positioned adjacent portion 47 of the core and coil unit, and brush 46 is spring biased into electrical engagement with the periphery of control plate 51. Terminal plate 43 is held in assembled relation with the transformer by any suitable means, such as an angle bracket that has one leg secured to the base 16 and the other leg secured to the terminal plate.

An open path for the flow of air through the central aperture 22 and the central bore or cooling channel of the core and coil unit 12 is maintained by the use of webs 41 and a plurality of spaced slots and holes in control plate 51. In addition, the flow of air through the unit is further promoted by the open space between the control plate 51 and the core and coil unit.

From the above it should now be clear that, by means of the resinous material 18 which firmly cements the lower portion of the core and coil member to the base 16, the core and coil are firmly bonded to the base member 16 and clamps or other members extending through the central opening of the core and coil unit for the purpose of holding the core and coil to the base are not required.

The base efficiently performs as a heat sink in the transformer assembly. Since the resinous material 18 flows between each of the wires of the coil and establishes intimate contact therewith the cross sectional area of the path for conducting thermal energy is relatively large and offers a highly conductive path for the transfer of heat from the core and coil to the base. This increased and intimate contact between the wires and resin also yields the additional benefit of a strong mechanical bond between the core and coil, resinous material, and base.

By the use of mounting pads 32, the base member 16 may be raised above any horizontal surface on which it is mounted. This will allow air to flow under and across the surface of base 16, through opening 22, and through the central opening of the core and coil unit. Heat that is generated within the core and coil is readily dissipated by conduction to the base and by convection currents to the surrounding atmosphere. The draft created by the chimney effect of the core and coil unit cools the bottom surface of the base as well as the core and coil.

Thus, when the base is mounted on a horizontal surface, heat is removed from the transformer unit by the air flowing across the bottom of the base and through the core and coil as well as by means of radiation and convection from the outer and upper surfaces of the unit.

When the transformer is mounted on a vertical surface the mounting pads 32 serve to space the base member 16 from the mounting surface which in combination with the base member 16 tends to produce a chimney effect. Thermal energy is removed from the core and coil by conduction to the heat sink base member and the convective air currents that flow through the core and coil, as well as by means of radiation and convection from the outer surfaces of the transformer assembly.

From the above it will be apparent that by means of the novel construction of this invention there is provided a novel toroidal transformer construction in which the heat generated within the transformer may be readily dissipated by means of thermal conduction, convection, and radiation, thereby allowing higher load current ratings for toroidal transformers constructed in this manner.

While there has been shown and described the present

5

preferred embodiment of the invention it will be apparent to those skilled in the art that various changes may be made without departing from the spirit and scope of the invention, particularly as defined in the appended claims.

What I claim as new and desire to secure by Letters Patent of the United States is:

1. A toroidal transformer construction comprising a core and coil unit formed of a magnetic core member having a coil wound thereon and a cooling channel there-through; a base member, said base member having an opening therein communicating with said cooling channel to provide a path for convective air currents that cool said transformer; and means comprising a cured resinous material for securing said core and coil unit to said base member, said means for securing providing a path for the conductive transfer of thermal energy from the core and coil unit to the base member.

2. The transformer construction of claim 1 wherein the resinous material is a silica filled epoxy resin.

3. The transformer construction of claim 1 wherein said base member provides a sink for thermal energy generated in said core and coil unit.

4. A toroidal transformer construction comprising a core and coil unit formed of a magnetic core member having a coil wound thereon, and a cooling channel there-through; a base member, said base member having an aperture therethrough communicating with said cooling channel to provide a path for convective air currents cooling said transformer; means securing said core and coil unit to said base without obstructing said path and providing a path for conduction of heat from said core and coil unit to the base; wherein said base provides a heat sink for thermal energy dissipated by the core and coil unit.

5. The transformer construction of claim 4 including means for supporting said base member in spaced relation to a mounting surface, the space between the base member and mounting surface co-operating with said path for convective air currents, to create a chimney effect so that air currents that flow through said path and past said base dissipate heat from the transformer.

6. The transformer construction of claim 4 wherein

6

the base member has a ring-shaped cavity formed therein about said aperture, the core and coil unit are positioned in said cavity, and said securing means comprises a cured resinous material that substantially fills said cavity about said core and coil unit.

7. A method of constructing a toroidal transformer comprising the steps of forming a toroidal core member, winding a coil about said core member to form a core and coil unit, making a base member, forming a ring-shaped cavity on said base member slightly wider than the thickness of said core and coil unit, placing spacer members in said cavity, placing said core and coil unit in said cavity on said spacer members, pouring a liquid resinous material into said cavity to completely surround the portion of said core and coil unit in said cavity and curing said resinous material to firmly cement said core and coil unit to said base.

8. A method of constructing a toroidal transformer comprising the steps of forming a toroidal core member, winding a wire coil about said core member to form a core and coil unit, making a base member, and forming a pair of concentric dams on said base member that are spaced apart a distance slightly wider than the thickness of said core and coil unit, placing said core and coil unit between said dams, supporting said core and coil unit above the adjacent surface of said base member, flowing a liquid resinous material between said dams, between said base and core and coil unit, and between the wires of the coil to intimately contact each of the wires, and curing said resinous material to firmly cement said core and coil unit to said base.

References Cited

UNITED STATES PATENTS

2,515,282	7/1950	Logan	-----	336-148	X
2,572,295	10/1951	Ziegler	-----	336-148	X
2,914,600	11/1959	Smith	-----	336-96	X
3,160,842	12/1964	Neumann	-----	336-61	X

DARRELL L. CLAY, *Primary Examiner*.

E. GOLDBERG, *Assistant Examiner*.