

(21) Application No 9000123.1

(22) Date of filing 04.01.1990

(30) Priority data

(31) 8900064

(32) 04.01.1989

(33) GB

(51) INT CL<sup>5</sup>

A63H 33/26

(52) UK CL (Edition K)

A6S S35

(56) Documents cited

US 3717951 A US 3550936 A

(58) Field of search

UK CL (Edition J) A6S

INT CL<sup>4</sup> A63H

(71) Applicant

Ilan Samson

62 Eshkol Street, Tel-Aviv, Israel

(72) Inventor

Ilan Samson

(74) Agent and/or Address for Service

Mewburn Ellis

2 Cursitor Street, London, EC4A 1BQ,

United Kingdom

(54) Magnetic amusement device

(57) An "adult toy" comprises a supporting structure in which are pivotally mounted suspending elements (16) with permanent magnets (12) at their lower ends. These magnets (12) form a row and are arranged so that each repels its neighbour(s). Their motion is constricted to swinging in the vertical plane containing the row. When one is set swinging a complex oscillation of the row results.

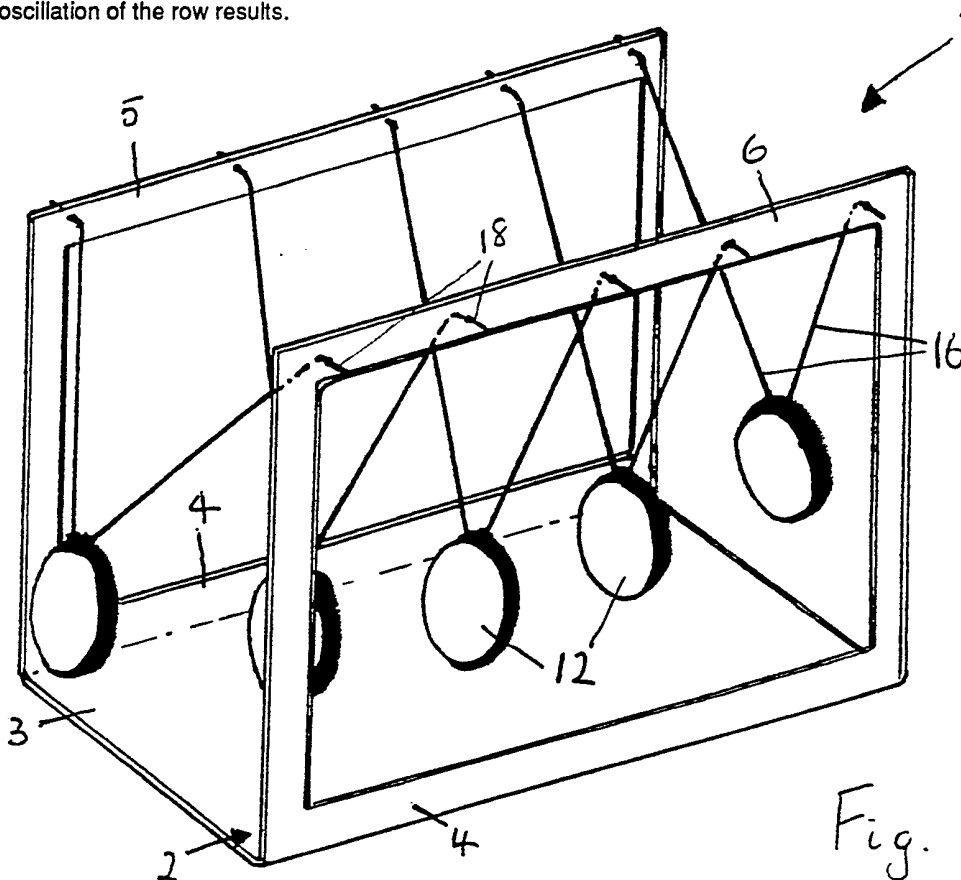

Fig. 1

1/4.

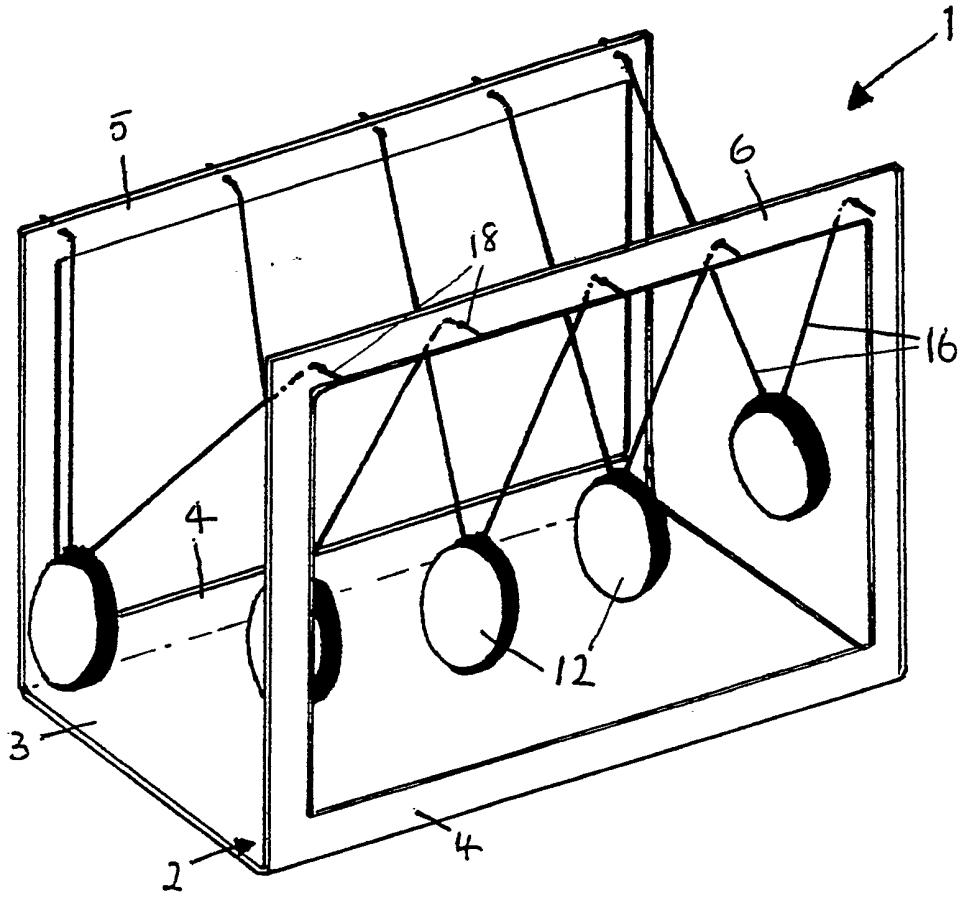

Fig. 1

2/4

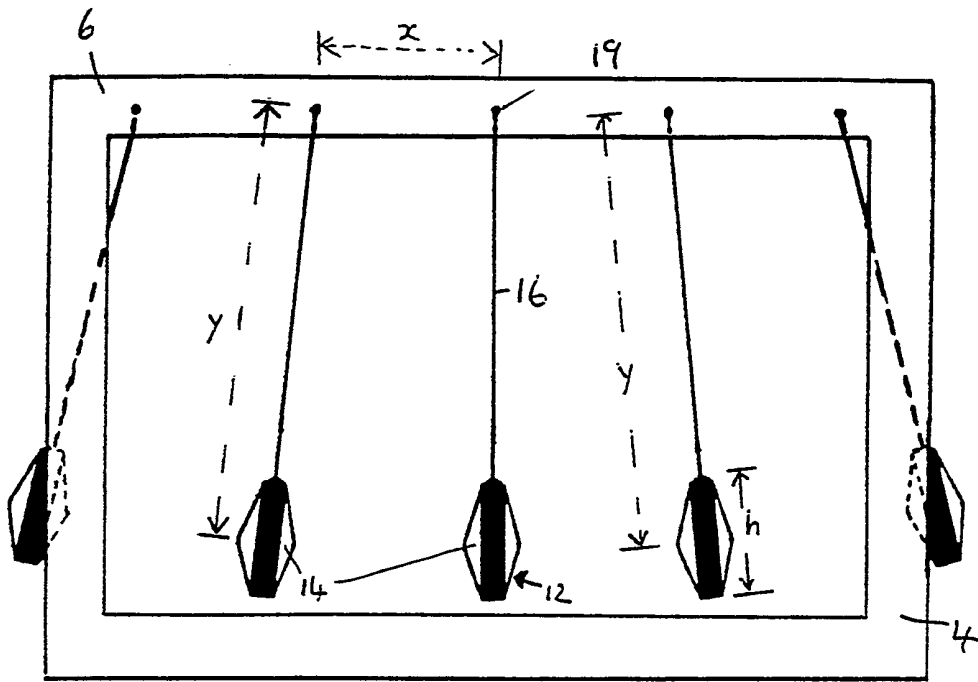

Fig. 2

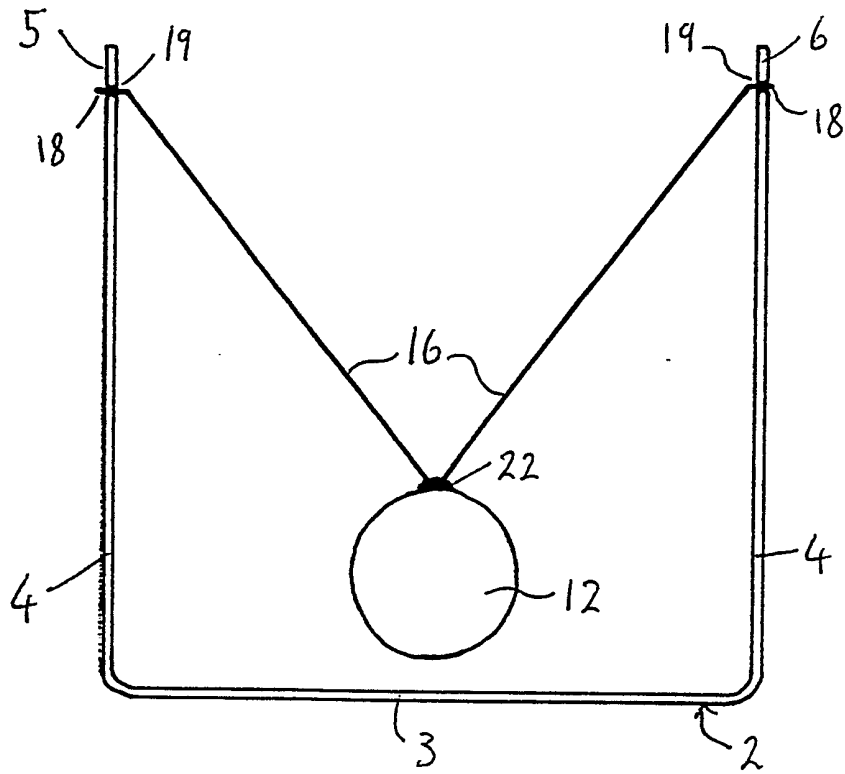

Fig 3

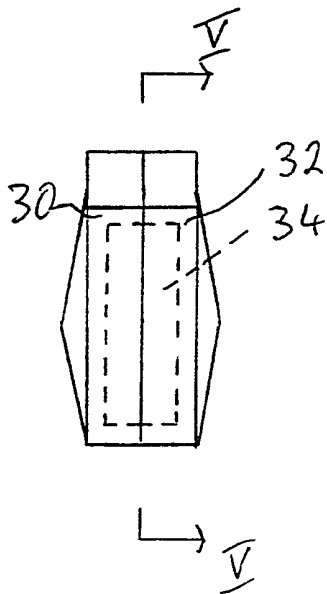

Fig 4

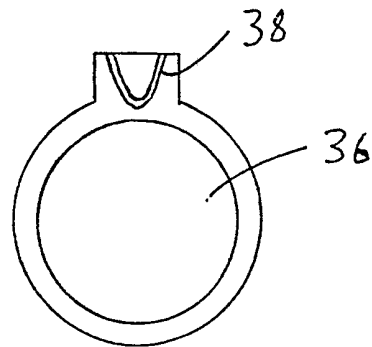

Fig 5

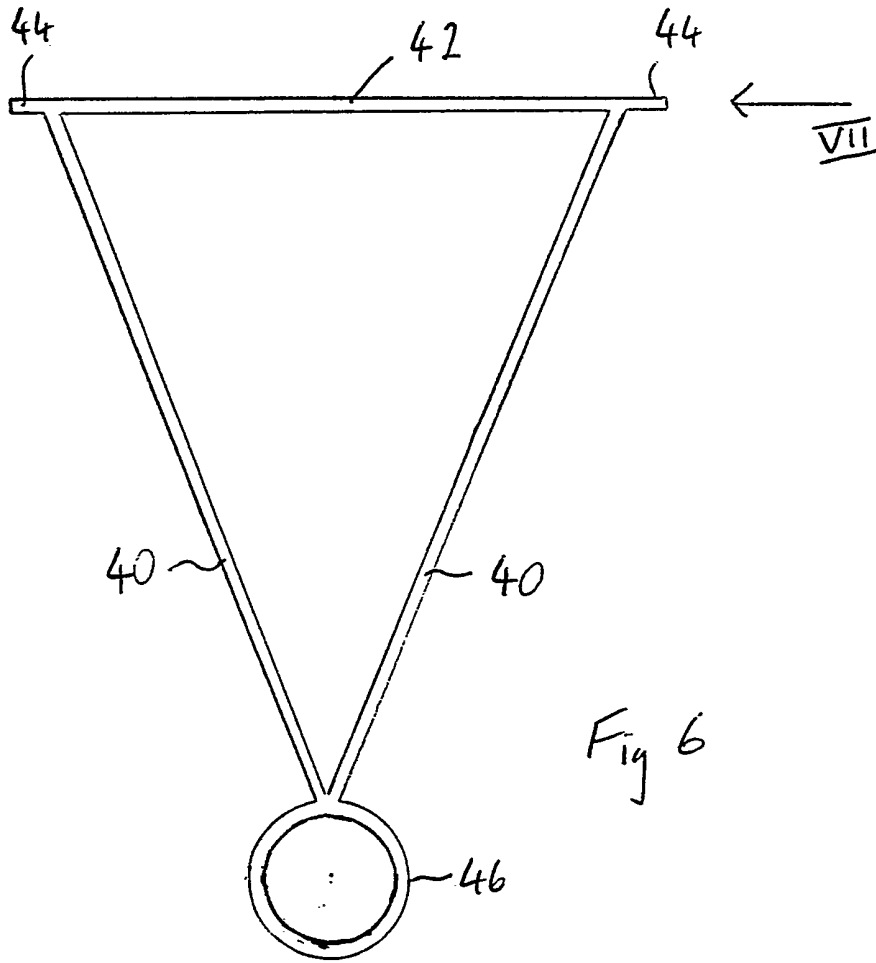

Fig 6

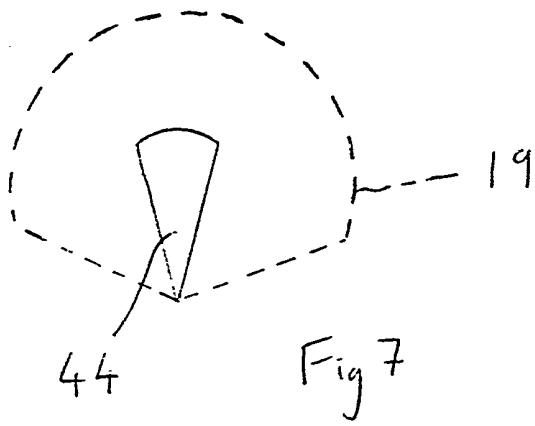

Fig 7

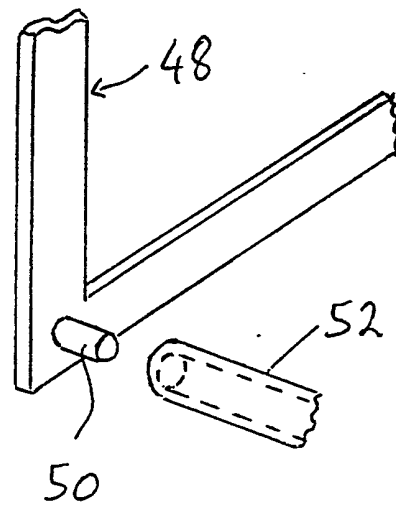

Fig 8

AMUSEMENT APPARATUS

This invention relates to an apparatus for amusement by providing an interesting motion of its parts.

The apparatus of this invention comprises:

5 a supporting structure,

at least two permanent magnets arranged in a row and spaced one from the next, each magnet being suspended from the structure to swing as a pendulum by means of a suspending element which is pivotally mounted on the structure so as to pivot around an axis extending transversely of the row,

each suspending element being sufficiently rigid to constrain its magnet to swing only in an arc extending generally along the row,

15 each magnet being secured to its suspending element, with adjacent magnets in the row oriented such that there is mutual repulsion between them.

It will usually be desirable that the axis of each magnet (i.e. its North-South direction) will be aligned along the direction of the said row of magnets.

20 The strength of the magnets should be sufficient that swinging motion of one magnet is transmitted through the mutual repulsion to the next magnet(s) in the row (and such that magnets moving towards each other will not normally touch).

25 With such an arrangement, motion of any one magnet sets the others in motion, and the motion is transmitted

from end to end along the row.

As one magnet approaches another, the mutual repulsion retards the approaching magnet, but accelerates the other magnet to move away from the approaching magnet.

5 Although the magnets do not touch, the effect is somewhat similar to collision in that kinetic energy is transferred from one magnet to the other. The effect is also somewhat different because the magnetic fields act at a distance so that transfer to kinetic energy occurs during a section of  
10 the travel of the magnets rather than at the (single) point of contact as with the collision of non-magnetic bodies.

The motion described by the magnets when one of them is set swinging bears some resemblance to the behaviour of a row of hard spheres, but is more complex. As one  
15 magnet approaches the next and repels it, that one is also approaching and repelling a third magnet. Moving one magnet in the row and letting it swing sets all the magnets in motion to some degree, and a complex motion of the magnets is observed.

20 The interaction of the magnets without one touching another is a striking sight. Another striking feature is the length of time during which motion will continue without any further impetus being given to the system. Motion has been observed to continue for much  
25 longer than with a row of hard spheres which undergo collision by touching.

Although the number of magnets in the row may be as few as two, it is desirable to employ at least three so

that motion can be transmitted from one end to the other through at least one magnet intermediately between the ends. The number of magnets preferably lies in the range from four to seven, with five being the most preferred number.

5           A very significant feature of the invention is the suspension of the magnets in a manner which constrains them to move only in a predetermined arc. This keeps them oriented to repel adjacent magnets and prevents them from jumping out of their intended paths of motion to positions  
10           at which two magnets can attract each other and become held to each other.

          Even with the rigid suspending elements required by this invention, it is possible (depending on dimensions) that if two adjacent magnets swing through a sufficient arc,  
15           they will no longer be face to face and repelling each other, but instead reach a position at which they are edge to edge so that the magnets can become held together by attraction between their unlike poles.

          This possibility is affected by the relationship  
20           between certain dimensions. Particularly significant are the spacing between the pivot axes of adjacent suspending elements and the dimension of each magnet in a direction radially from the pivot axis of its suspending element. The latter is the height of the magnet when hanging vertically  
25           downwards and for convenience will be referred to as the "height".

          If the spacing between adjacent pivot axes is less than the heights of the associated magnets, then they will



not reach the edge to edge condition at which they become held together by attraction, even if they are swung upwardly through  $90^\circ$  in the same direction. If the spacing is more than the heights of the magnets it is possible for the magnets to reach an edge to edge condition and become held together. However, if the spacing is not much more than the heights, the magnets will not reach an edge to edge condition and become held together until they have been swung upwardly through a substantial angle.

10           Generally it is sufficient to choose the dimensions such that adjacent magnets cannot become held together until they have swung upwardly through at least  $60^\circ$ .

15           An alternative, but not preferred, possibility will be to suspend the magnets with a spacing between pivot axes which is substantially greater than the rest heights of the magnets, for example 3 or 4 times as much.

20           Another way to express suitable spacing of the pivot axes is that the spacing between the pivot axes of adjacent magnets should either be less than about 1.5 times the height of a magnet or should be at least about as great as the distance from a pivot axis to the further edge of the magnet suspended from the axis.

25           Generally the lengths of the suspending elements will be greater than the spacing between their axes. Thus, the length of each suspending element, from the centre of the magnet to the pivot axis is preferably more than twice the spacing between the pivot axes of adjacent elements.

The strength of the magnets is a significant consideration. As a practical guide, the magnetic repulsion should be strong enough that if two adjacent magnets are each swung up to  $50^\circ$  to the vertical in opposite directions and released, so as to fall towards each other, they do not touch each other. Better, they should not touch even if released from an angle of  $60^\circ$  to the vertical.

In a convenient constructional arrangement, the supporting structure includes side members at either side of the row of magnets and each suspending element is pivotally mounted in or on both side members.

The suspending elements need to be sufficiently rigid to keep the magnets in their intended paths of movement. Convenient possibilities are a V-shape or T-shape, made from stiff, non-magnetic wire with the upper extremities of the V or T pivotally mounted in the side members and the magnet secured to the base of the V or T. The upper ends of a V-shaped suspending element may be connected by a cross-piece, so that the V-shape becomes an inverted triangle. Suspending elements may be moulded from plastic with such a triangular shape.

Securing of the magnets to their suspending elements can be accomplished in various ways. One possibility is for them to be glued together with a blob of adhesive or resin. Another possibility is for each magnet to be surrounded by a casing moulded in two parts which fit together and surround both the magnet and the lower part of its suspending element, thereby attaching them together. A

moulded plastic suspending element may include an integral mounting into which a magnet will force fit.

An embodiment of the invention will now be described in detail, with reference to the accompanying drawings, wherein:

Figure 1 is a perspective view of one embodiment of the apparatus according to the invention;

Figure 2 is a side view thereof;

Figure 3 is an end view thereof;

Figure 4 is a side view of an alternative magnet casing;

Figure 5 is a section on line V-V of Figure 4;

Figure 6 shows an alternative suspending element;

Figure 7 is an enlarged view on arrow VII of Figure 6; and

Figure 8 is a detail of an alternative supporting structure.

The apparatus has a supporting structure, referred to as a frame, shown generally as 2 in Figure 1. This comprises a flat, continuous, horizontal base 3 and parallel vertical sides 4, forming a channel section. Each side 4 has a cut away central portion, as seen in Figure 1. This allows a relatively unobstructed view of, and access to the elements 12 of the apparatus.

The frame 2 may be made of any suitable hard, rigid material. Preferably it is moulded from transparent plastic.

Pivotally mounted in the frame 2 are five

suspending elements 16. Each is formed from a length of stout metal wire bent into a symmetrical V-shape with its upper free ends 18 turned outwardly. The suspending element could alternatively be formed by a plastic moulding.

5                   The free ends 18 of each suspending element 16 engage in holes 19 in upper parts 5,6 of the frame and are free to pivot in these holes 19. Thus each suspending element is pivoted to the frame to swing about an axis extending across the frame from one side to the other.

10                   It is desirable that the suspending elements 16 should have some resilience, so that the free ends 18 can be inserted in the pivot holes 19 by simply forcing the ends 18 together slightly, aligning the ends 18 with the holes 19, and then releasing them. This could allow the user to  
15 remove some suspending elements, or to change their spacing by moving them to alternative pivot holes (not shown). Another possibility is that the suspending elements can be fitted or removed by pulling the top edges of the sides 4 away from each other, instead of pushing the ends 18  
20 together.

                  At the bottom of each V-shaped suspending element 16 there is a magnetic element 12 consisting of a permanent magnet which may possibly be encased in a protective casing of thermosetting resin. Each element 12 is approximately a  
25 disc, but with slightly conical faces 14. The suspending element 16 is secured to the magnetic element 12 with a blob of the resin or of an adhesive.

                  As can be seen from the drawings the magnetic

elements 12 are spaced apart in a row. The magnet within each magnetic element 12 is oriented with its north-south direction generally in the longitudinal direction of the row. Adjacent magnets are oriented with like poles facing each other, so that there is mutual repulsion therebetween.

In the embodiment shown, there are five such magnetic elements 12 and suspending elements 16. However, a different number may be used depending on the length of the frame and the size of the apparatus required.

The axes around which the suspending elements pivot are spaced apart, one from the next, by a distance  $x$ . The relative disposition of the magnetic elements 12, when at rest, is shown in Figure 2. Mutual repulsion between adjacent elements spaces them apart by more than the distance  $x$ . The outer suspending elements do not hang vertically.

Each magnetic element 12 is suspended, by means of its suspending element 16 to swing as a pendulum with the magnetic element moving in an arc which extends in the longitudinal direction of the row of elements 12. It is retained in this arc by reason of the rigidity of the suspending element 16.

The parts of the apparatus may be set in motion by moving any magnetic element 12. For example an end-most magnetic element is swung upwardly and outwardly from the frame and released. A regular but complex motion results. It continues for some time until damped by friction, air resistance and any hysteresis losses. Motion has been

observed to continue for as long as 25 minutes.

If two adjacent magnetic elements 12 are displaced together in the same longitudinal direction, due to the spacing of the pivot holes 19 (designated  $x$  in Figure 2), the two elements instead of remaining in substantially face to face relationship can approach to substantially edge to edge relationship, which may result in the two magnets mutually attracting. During the normal oscillating motion of the parts this should not occur, and can be substantially prevented by selecting the height  $h$  in relation to the spacing  $x$ , so that the two magnetic elements 12 are not sufficiently in a side to side relation so as to attract each other until their supporting elements are at an angle of at least  $70^\circ$  to the vertical.

Allowing two elements to become held together at such a high angle may be useful in enabling two elements to be held up, out of the way. The motion of the remaining three elements can then be seen.

As is preferred, although not essential, the spacing between each pair of adjacent pivot axes is the same. The heights  $h$  of the magnetic elements 12 are equal. The lengths of the suspending elements 16 are also equal to each other. They are such that the distance  $y$  is more than twice the spacing  $x$  which does not exceed  $1\frac{1}{2}$  times the height  $h$ . If the less preferred possibility of a wide spacing  $x$  between pivot axes is used,  $x$  should then be approximately equal to, or greater than,  $y + \frac{1}{2} h$ .

Figures 4 and 5 illustrate a modified enclosure

for a magnet. As shown by Figure 4, which is a side view, it is made in two halves 30,32 which receive a cylindrical magnet 34.

Figure 5 shows the interior of one half 32. It has a central cavity 36 to receive one end of the magnet and a groove 38 to receive the bottom part of a suspending element 16. The other half has a similar cavity and groove. The two halves are fitted together around a magnet 34 and the bottom end of a suspending element and thereby secure the magnet to the suspending element.

Figures 6 and 7 illustrate an alternative suspending element. It is a one-piece plastic moulding with two descending portions 40 joined by a cross-piece 42. Extensions 44 of the cross-piece are inserted into holes 19 in the supporting structure, analogously to the end portions 18 shown in Figure 3. At the base of the descending portions 40 there is a ring 46 into which a disc-shaped magnet can be fitted. The internal diameter of the ring 46 is arranged so that the magnet is a (gentle) force fit.

Figure 7 shows the cross-section of an extension 44. It is a narrow V-shape and gives a knife edge pivot in a hole 19 which incorporates a wider V-shaped lower edge. The end portions 18 shown in Figure 3 may likewise be shaped to provide a knife edge pivot.

Figure 8 illustrates an alternative supporting structure. The Figure shows an inside lower corner of one side piece.

This supporting structure has two side pieces 48

which have the same appearance as the sides 4 in Figure 1, i.e. each is rectangular with a cut out central area.

However, each side piece 48 is a separate plastic moulding and has a dowel 50 projecting inwardly from each lower

5 corner. The two side pieces are connected after moulding by pushing the dowels into the ends of the two plastic tubes 52

which form the base of the structure. The dowels 50 are

dimensioned to be a (gentle) force fit in the tubes 52. In

Figure 8 the end of one tube 52 is shown ready for the dowel

10 50 to be pushed into it.



CLAIMS:

1. An apparatus for amusement, comprising:  
a supporting structure,  
5 at least two permanent magnets arranged in a row  
and spaced one from the next, each magnet being suspended  
from the structure to swing as a pendulum by means of a  
suspending element which is pivotally mounted on the  
structure so as to pivot around an axis extending  
10 transversely of the row,  
each suspending element being sufficiently rigid  
to constrain motion of its magnet only to swinging in an arc  
extending generally along the row,  
each magnet being secured to its suspending  
15 element, with adjacent magnets in the row oriented such that  
there is mutual repulsion between them.
2. Apparatus according to claim 1 wherein the axis of  
each magnet between the poles thereof is aligned along the  
direction of the said row of magnets.
- 20 3. Apparatus according to claim 1 or claim 2 wherein  
the number of magnets in the row lies in the range from four  
to seven.
4. Apparatus according to any one of the preceding  
claims wherein the spacing between the pivot axes of

successive magnets in the row is such that the magnets continue to repel each other while swinging until swung upwardly through at least 60°.

5. Apparatus according to any one of the preceding  
5 claims wherein the supporting structure comprises a pair of upright side members disposed one at each side of the row, with each suspending element pivotally mounted to both side members.

6. Apparatus according to any one of the preceding  
10 claims wherein the magnets are disc-shaped.

7. Apparatus according to any one of the preceding claims wherein the suspending elements are detachable from the supporting structure.

8. Amusement apparatus substantially as any herein  
15 described and illustrated with reference to the accompanying drawings.