

(No Model.)

3 Sheets—Sheet 1.

C. J. A. SJOBERG.
TYPE WRITING MACHINE.

No. 492,844.

Patented Mar. 7, 1893.

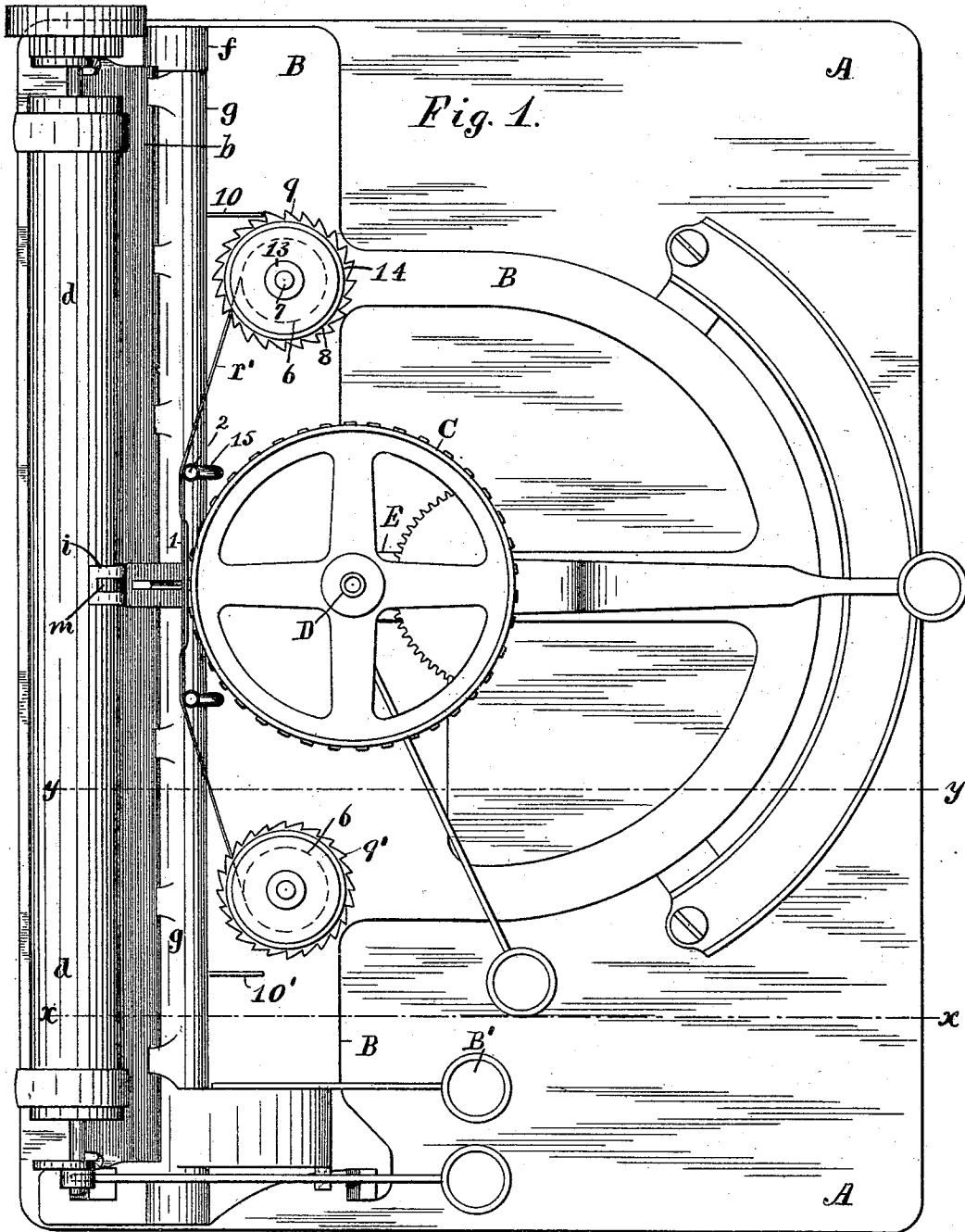

Attest:
L. Lee,
Edw. V. Kinsley

Inventor.
C. J. A. Sjoberg, per
Crane & Miller, Atty.

C. J. A. SJOBERG.
TYPE WRITING MACHINE.

No. 492,844.

Patented Mar. 7, 1893.

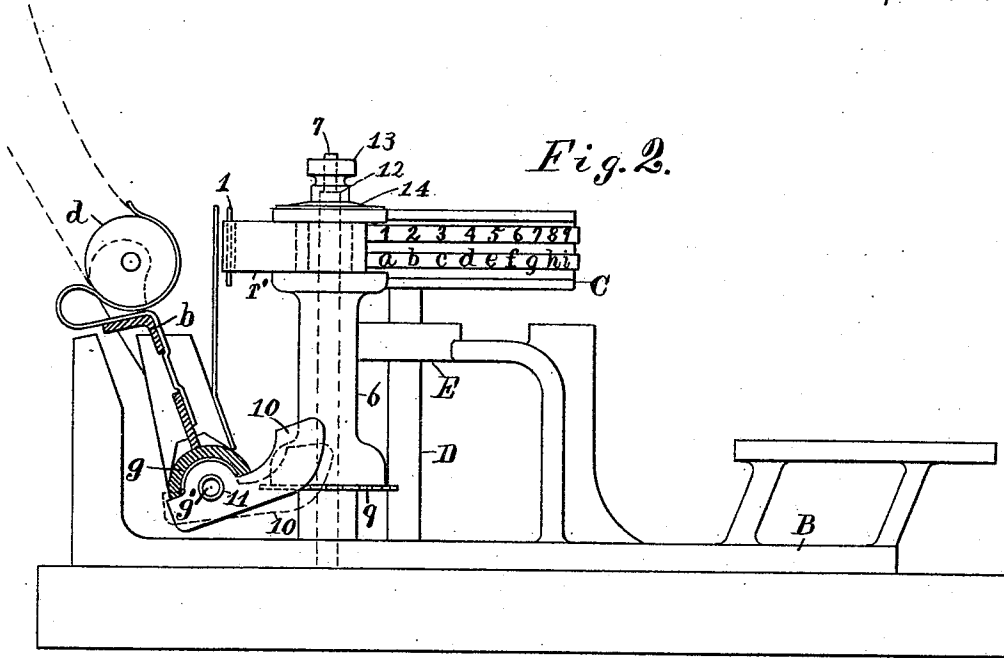

Fig. 2.

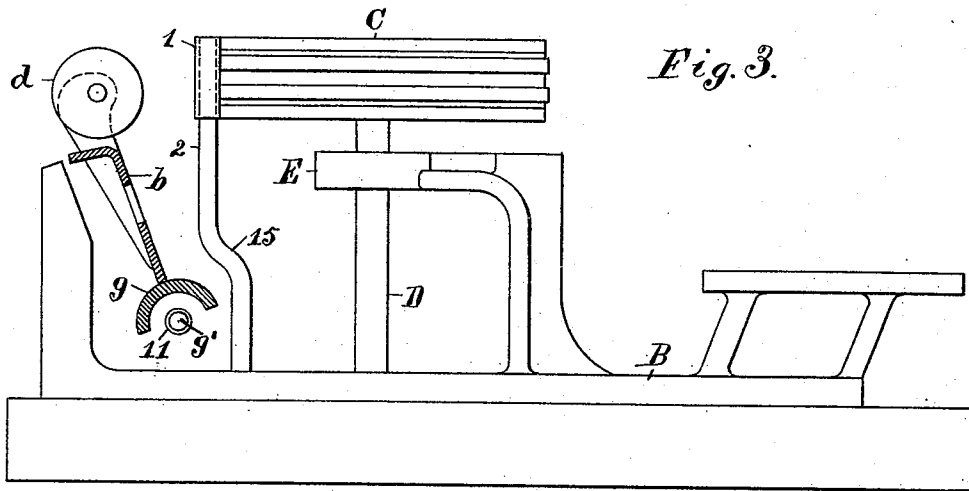

Fig. 3.

Attest:
L. Lee.
N. Kinsey

Inventor:
C. J. A. Sjöberg, per
Crane & Miller, Atty

C. J. A. SJOBERG.
TYPE WRITING MACHINE.

No. 492,844.

Patented Mar. 7, 1893.

Fig. 6.

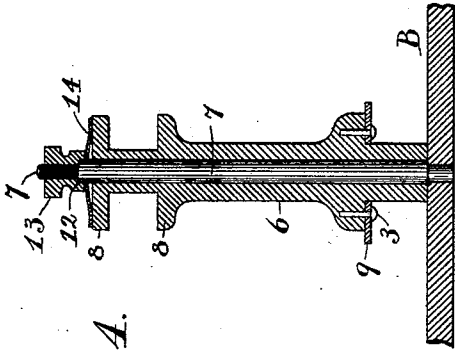
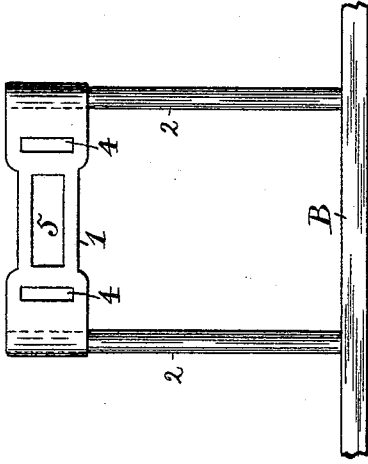
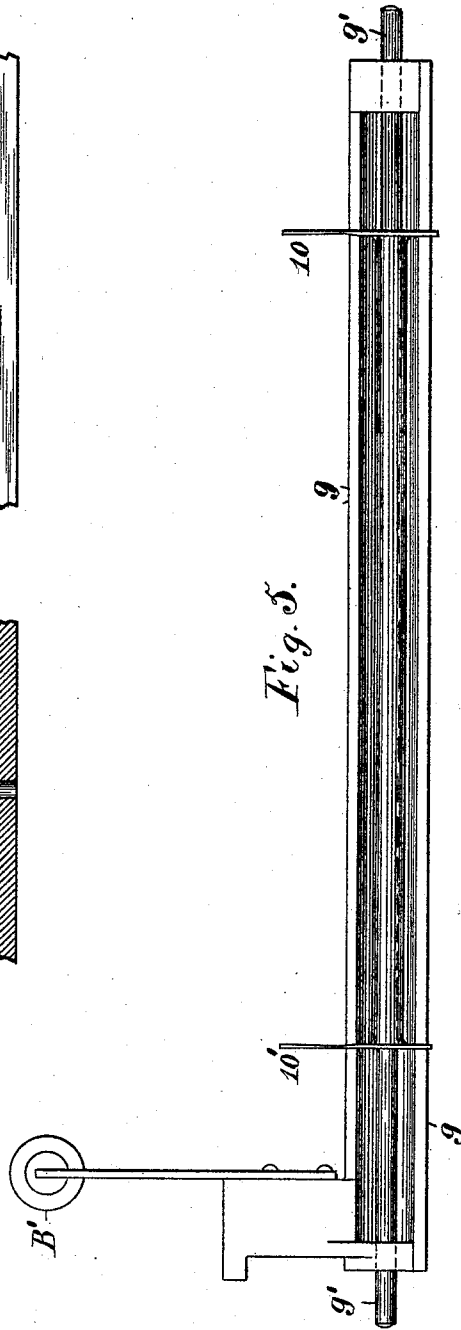

Fig. A.

Fig. 5.



Attest:
L. Lee.
Edw. H. Kinsey.

Inventor:
C. J. A. Sjoberg, per
Crane & Miller, Atty.

UNITED STATES PATENT OFFICE.

CARL J. A. SJOBERG, OF BROOKLYN, ASSIGNOR TO THE GARVIN MACHINE COMPANY, OF NEW YORK, N. Y.

TYPE-WRITING MACHINE.

SPECIFICATION forming part of Letters Patent No. 492,844, dated March 7, 1893.

Application filed September 2, 1892. Serial No. 444,922. (No model.)

To all whom it may concern.

Be it known that I, CARL J. A. SJOBERG, a citizen of the United States, residing at Brooklyn, Kings county, New York, have invented certain new and useful Improvements in Type-Writing Machines, fully described and represented in the following specification and the accompanying drawings, forming a part of the same.

The present improvements relate to that class of typewriting machines in which a platen is mounted upon a rocking frame and vibrated to and from type upon the periphery of a wheel, to make the printing impressions.

The improvements are especially applicable to the machine patented by me January 20, 1891, No. 445,128, in which the type wheel is mounted upon a vertical spindle and the platen is formed of an elastic impression roller mounted upon the upper part of a rocking frame. The paper is wrapped around the platen, and a finger key is provided to vibrate the frame after each adjustment of the type wheel, thus pressing the paper toward the type as desired.

The present improvements consist in means for actuating the inking ribbon, and means for regulating the tension of the same.

The construction will be understood by reference to the annexed drawings, in which

Figure 1 is a plan of the machine. Fig. 2 is a section of the same on line x, x , in Fig. 1. Fig. 3 is a plan on line y, y , in Fig. 1. Fig. 4 is a section of one of the ribbon spools and its tension device. Fig. 5 shows the under side of the rocker frame inverted, with the feed pawls and their connecting sleeve; and Fig. 6 is an elevation of the ribbon guide and its standards.

In Fig. 1, only the parts relating to the present invention are shown, as the construction and operation of the other parts are fully set forth in my Patent No. 445,128, dated January 20, 1891.

The same letters and figures are used for the same parts in the present drawings as in the said patent.

In the drawings, A is a foot board, B the metallic bed of the machine secured thereon,

C the type wheel, D its spindle, and E its bracket bearing.

f are the supports for the shaft g' of the rocker frame g .

b is the sliding carriage mounted upon the rocker frame and carrying the elastic cylindrical platen d .

B' is a key or lever attached to the end of the rocker frame g and operates, when pressed downward, to tip the frame and carriage b forward, and thus press the platen d against the type upon the wheel C.

A ribbon guide 1 is sustained by posts 2 between the type wheel and the platen, and a ribbon r' is extended between spools 6 and threaded through slots 4 in the ribbon guide so as to lie between the same and the type wheel.

An aperture 5 is formed through the center of the ribbon guide, between the slots 4, to permit the type to press the ribbon upon the paper. A guard i is fixed to the rocking frame and provided with an aperture m adjacent to the center of the platen d , thus protecting the paper adjacent to the type impression from contact with the ribbon.

The shaft g' , upon which the rocking frame carrying the platen oscillates, is arranged almost directly below the edge of the type wheel; so that the pressure of the platen may be at right angles with the surface of the type, and such construction interferes with the mounting of the posts 2 below the ends of the ribbon guide 1, and the posts are therefore formed with an offset or bend 15, by means of which the posts are inserted in the bed plate E adjacent to the edge of the rocker frame g , while their upper ends are in a line with the inner face of the type wheel. The ribbon guide 1 may be detachable from the posts, but is preferably attached thereto so as to avoid derangement, as it is found that the ribbon may be readily threaded through the slots 4 without displacing the guide. The spools 6 are mounted upon studs 7 which are projected upward from the bed plate B at each side of the type wheel. Flanges 8 retain the ribbon r' in place, and each spool is provided, at the level of the shaft g' , with a ratchet wheel 9 or

9', actuated by a pawl 10 or 10' upon the shaft g' . As shown in Fig. 5, two of the pawls are attached to a single sleeve 11 which is movable upon the shaft g' , the pawls consisting in elastic plates of sheet metal projected outward by the sides of the ratchet wheels; but at a suitable distance apart to engage only one of such ratchet wheels at once, when pushed into contact with the same, as shown at the ratchet wheel 9 in Fig. 1. Each pawl is formed upon its upper side to fit the under edge of the rocker frame g , and the sleeve 11 with the two pawls is thus vibrated at each actuation of the key B'. The position of a pawl, produced by depressing the finger key, is shown in the dotted lines 10 in Fig. 2, the edge of the pawl being eccentric in relation to the shaft g' and thus adapted to push the ratchet wheel around one tooth at each vibration of the pawl. As shown in Fig. 5, the metal of the pawl is made thin and yielding adjacent to the sleeve 11, so that after each actuation the pawl readily springs into the adjacent tooth as it is lifted into the position shown in the full lines 10 in Fig. 2. The sleeve 11 is made of thin elastic metal and fitted snugly to the shaft g' so as to retain its position when moved longitudinally to bring either the pawl 10 or 10' into contact with the opposed ratchet wheel. The ratchet wheels upon the two spools face in opposite directions, and when the ribbon is wholly wound upon one of the spools, as shown in the upper side of Fig. 1, and unwound from the other spool, the sleeve 11 is pushed longitudinally by the finger upon the shaft g' , and the pawl 10' is engaged with the lower ratchet wheel, thus actuating the latter, and winding the ribbon in the opposite direction. The tension upon the spools is fixed positively by means of a tension disk compressed to a given point. To secure such adjustment, I form a shoulder 12 upon the stud 7 above the top of the spool, and the nut 13 is screwed to a bearing upon such shoulder, and thus operates to clamp a tension disk or washer 14 to a given point, as shown in Fig. 4. To avoid the contact of the tension disk with the thread above the shoulder, I recess the under side of the adjusting nut so as to project downward from the shoulder and to thus clamp the disk below the level of the same. By this construction, the tension upon the spools is regulated to a predetermined degree, and an inexperienced operator is prevented from crowding the disk 14 against the spool excessively, and thus producing an undue strain upon the ribbon, the feed pawls, and the finger key B'.

By the connection of the two pawls with a single sleeve and their actuation by the rocking frame g , the feed mechanism is simplified in a very high degree, and the highest efficiency is secured with a very slight expense.

By the provision of the slots 4 in the ribbon guide the ribbon is held upon the oppo-

site side of the guide from the paper for a considerable distance adjacent to the type impression, and the ribbon is thus prevented from contact with the paper when pressed toward the type. The spools 6 are preferably made of wood, with the metallic ratchet wheels 9 attached thereto by pins or screws 3, as shown in Fig. 4, thus forming a very cheap construction, which is entirely effective in feeding the ribbon back and forth before the type.

What I claim herein is—

1. In a typewriter having a platen and rocker frame mounted upon a shaft g' for vibrating the platen to and from a type wheel, the combination, with a ribbon spool mounted adjacent to the rocker frame, of a ratchet wheel adjacent to the shaft g' and an elastic pawl mounted upon the shaft g' and vibrated positively with the rocker frame to actuate the ratchet wheel, substantially as herein set forth.

2. In a typewriter having a platen and rocker frame mounted upon a shaft g' for vibrating the platen to and from a type wheel, the combination, with spools mounted adjacent to the rocking frame, of a ribbon extended between the spools, ratchet wheels upon the spools adjacent to the shaft g' , and two elastic pawls mounted adjacently upon the shaft g' and actuated by the rocker frame to operate the ratchet wheels alternately, as set forth.

3. In a typewriter having a platen and rocker frame mounted upon a shaft g' for vibrating the platen to and from a type wheel, the combination, with ribbon spools mounted adjacent to the rocker frame and provided with ratchet wheels, of a sleeve adjustable upon the shaft g' and provided with pawls to engage the spools alternately as the sleeve is shifted longitudinally, as set forth.

4. In a typewriting machine, the combination, with a fixed stud 7 having the ribbon spool 6 mounted thereon and provided with the shoulder 12 above the top of the spool, of the tension disk 14 applied to the stud below the shoulder, and the nut 13 provided with recess to engage the shoulder and operated to compress the disk in a fixed degree, as set forth.

5. In a typewriter having a platen and rocker frame mounted upon a shaft g' for vibrating the platen to and from a type wheel, the combination, with ribbon spools mounted at opposite sides of the type wheel and provided with ratchet wheels as set forth, of the ribbon guide 1 mounted upon the posts and provided with the slots 4 and the aperture 5, the ribbon threaded through the slots as described, the sleeve 11 adjustable upon the shaft g' and the pawls 10, 10' adjustable with the sleeve and vibrated with the rocker frame, the whole arranged and operated substantially as set forth.

6. In a typewriter, the combination, with

5 the stud 7 fixed to the bed plate, of the spool 6 fitted to turn upon the stud and formed of wood as set forth, and provided with the flanges 8 to retain the ribbon in place, a tension spring pressed upon the top of the spool by a nut, and a metallic ratchet wheel attached to the spool by the pins or screws 3, substantially as herein set forth.

In testimony whereof I have hereunto set my hand in the presence of two subscribing witnesses.

CARL J. A. SJOBERG.

Witnesses:

THOMAS S. CRANE,
A. C. SJOBERG.