

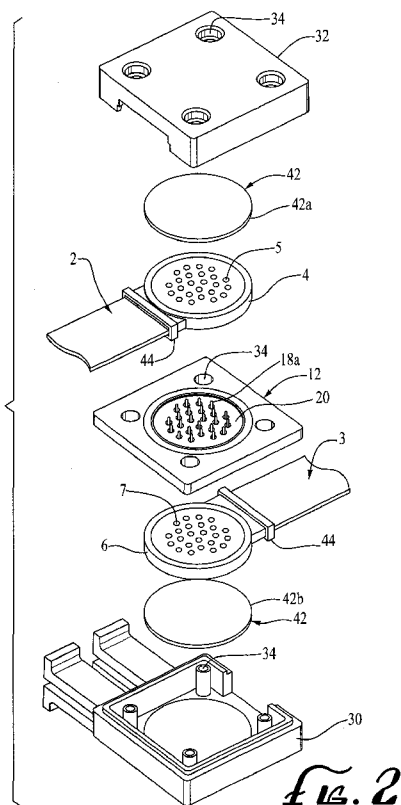

- (51) **International Patent Classification:**  
*H01R 12/59* (2011.01) *H01R 12/77* (2011.01)
- (21) **International Application Number:**  
PCT/US2012/029957
- (22) **International Filing Date:**  
21 March 2012 (21.03.2012)
- (25) **Filing Language:** English
- (26) **Publication Language:** English
- (71) **Applicant (for all designated States except US):** **HI REL CONNECTORS, INC.** [US/US]; 760 West Wharton Drive, Claremont, California 91711 (US).
- (72) **Inventors; and**
- (75) **Inventors/Applicants (for US only):** **ESQUIVEL, Derick** [US/US]; 760 West Wharton Drive, Claremont, California 91711 (US). **WILLIAMS, Willis** [US/US]; 760 West Wharton Drive, Claremont, California 91711 (US).
- (74) **Agents:** **OBI, Iloputaife et al.**; Cotman IP Law Group, PLC, 117 E. Colorado Blvd, Ste 460, Pasadena, CA 91105 (US).
- (81) **Designated States (unless otherwise indicated, for every kind of national protection available):** AE, AG, AL, AM, AO, AT, AU, AZ, BA, BB, BG, BH, BR, BW, BY, BZ, CA, CH, CL, CN, CO, CR, CU, CZ, DE, DK, DM, DO, DZ, EC, EE, EG, ES, FI, GB, GD, GE, GH, GM, GT, HN, HR, HU, ID, IL, IN, IS, JP, KE, KG, KM, KN, KP, KR, KZ, LA, LC, LK, LR, LS, LT, LU, LY, MA, MD, ME, MG, MK, MN, MW, MX, MY, MZ, NA, NG, NI, NO, NZ, OM, PE, PG, PH, PL, PT, QA, RO, RS, RU, RW, SC, SD, SE, SG, SK, SL, SM, ST, SV, SY, TH, TJ, TM, TN, TR, TT, TZ, UA, UG, US, UZ, VC, VN, ZA, ZM, ZW.
- (84) **Designated States (unless otherwise indicated, for every kind of regional protection available):** ARIPO (BW, GH, GM, KE, LR, LS, MW, MZ, NA, RW, SD, SL, SZ, TZ, UG, ZM, ZW), Eurasian (AM, AZ, BY, KG, KZ, MD, RU, TJ, TM), European (AL, AT, BE, BG, CH, CY, CZ, DE, DK, EE, ES, FI, FR, GB, GR, HR, HU, IE, IS, IT, LT, LU, LV, MC, MK, MT, NL, NO, PL, PT, RO, RS, SE, SI, SK,

[Continued on next page]

(54) **Title:** FLEX TO FLEX CONNECTION DEVICE



(57) **Abstract:** A mechanical device 10 for electrically connecting a first flexible assembly 2 to a second flexible assembly 3 comprises a wafer 12 and a housing 14. The wafer 12 has an insulator core 16 and a plurality of wafer electrical connectors 18. The core has a first base side 20 and an opposed second base side 22. The wafer electrical connectors 18 include a first set of wafer electrical connector contacts 18a exposed on the first base side 20 and a second set of wafer electrical connector contacts 18b exposed on the second base side 22. Each wafer electrical connector is adapted to electrically connect with a flexible assembly electrical contact 5,7. The housing 14 retains the wafer 12, the first flexible assembly 2, and the second flexible assembly 3 in such a way that each of the flexible assembly electrical contacts 5,7 is removably secured and electrically connected to one of the wafer electrical connector contacts 18.

WO 2013/141858 A1

SM, TR), OAPI (BF, BJ, CF, CG, CI, CM, GA, GN, GQ, GW, ML, MR, NE, SN, TD, TG). **Published:**

— with international search report (Art. 21(3))

## FLEX TO FLEX CONNECTION DEVICE

5

### FIELD OF THE INVENTION

The invention relates generally to electrical connection assemblies and, more particularly, to connection assemblies comprising a pair of flexible electrical conductors.

10

### BACKGROUND OF THE INVENTION

15

Sophisticated electrical and electronic components are frequently disposed proximate to high vibration equipment, such as aircraft and rocket engines. Because of the narrow confines wherein such components are typically disposed, interconnecting such components often employs the use of flexible electrical conductors (“flexible assemblies”).

20

The prior art methods of attaching a flexible assembly to another flexible assembly usually employ some form of permanent attachment, such as methods wherein the flexible assemblies are soldered to one another.

25

Problems arise in such prior art methods when the attachment between the two flexible assemblies fails. Such failures cannot easily (if at all) be repaired in the field, and, in most cases, require the complete replacement of both flexible assemblies. Such complete replacement of both assemblies can be awkward, time-consuming and expensive.

30

Accordingly, there is a need for a method of attaching a flexible assembly to another flexible assembly which does not involve the aforementioned problems in the prior art.

**SUMMARY OF THE INVENTION**

The invention satisfies this need. The invention is a mechanical device for electrically connecting a first flexible assembly to a second flexible assembly, wherein the first flexible assembly comprises a first flexible assembly terminal end having a plurality of first flexible assembly electrical contacts and the second flexible assembly comprises a second flexible assembly terminal end having a plurality of second flexible assembly electrical contacts, the invention comprising (a) a wafer comprising an insulator core and a plurality of wafer electrical connectors, the core having a first base side and an opposed second base side, the wafer electrical connectors comprising a first set of wafer electrical connector contacts exposed on the first base side and a second set of wafer electrical connector contacts exposed on the second base side, each electrical contact in the first set of wafer electrical connector contacts being electrically connected to a corresponding electrical contact in the second set of wafer electrical connector contacts, each wafer electrical connector contact being sized and dimensioned to electrically connect with a first flexible assembly electrical contact or a second flexible assembly electrical contact, and (b) a housing for accepting and retaining (i) the wafer, (ii) the first flexible assembly terminal end disposed adjacent to the first base side of the wafer, and (iii) the second flexible assembly terminal end disposed adjacent to the second base side of the wafer, such that each of the first flexible assembly electrical contacts is removably secured and electrically connected to the first set of wafer electrical connector contacts and each of the second flexible assembly electrical contacts is removably secured and electrically connected to the second set of wafer electrical connector contacts.

**DRAWINGS**

Figure 1 is a perspective view of a mechanical device of the invention;

5 Figure 2 is an exploded view of the mechanical device illustrated in Figure 1;

Figure 3 is a top view in partial cross-section of the mechanical device illustrated in Figure 1;

10 Figure 4 is a cross-sectional side view of the mechanical device illustrated in Figure 1; and

Figure 5 is a detail view of a portion of the mechanical device illustrated in Figure 4.

15

**DETAILED DESCRIPTION OF THE INVENTION**

20 The following discussion describes in detail one embodiment of the invention and several variations of that embodiment. This discussion should not be construed, however, as limiting the invention to those particular embodiments. Practitioners skilled in the art will recognize numerous other embodiments as well.

25 The invention is a mechanical device 10 for electrically connecting a first flexible assembly 2 to a second flexible assembly 3. The first flexible assembly comprises a first flexible assembly terminal end 4 having a plurality of first flexible assembly electrical contacts 5, and the second flexible assembly comprises a second flexible assembly terminal end 6 having a plurality of second flexible assembly electrical contacts 7. The invention comprises a wafer 12 and a housing 14.

30

The wafer 12 is responsible for passing electrical signals and/or power distribution from one flexible assembly to the other.

The wafer 12 comprises an insulator core 16 and a plurality of wafer electrical connector contacts 18. The insulator core 16 can be a hermetic glass insulator 36.

5 The wafer electrical connector contacts 18 comprise a first set of wafer electrical connector contacts 18a exposed on a first base side 20 of the wafer 12 and a second set of wafer electrical connector contacts 18b exposed on a second base side 22 of the wafer 12. Each electrical contact 18 in the first set of wafer electrical connector contacts 18a is electrically connected to a corresponding electrical contact 18 in the second set of wafer electrical connector contacts 18b. Each wafer electrical contact 18 is sized and dimensioned to  
10 electrically connect with a first flexible assembly electrical contact 5 or a second flexible assembly electrical contact 7.

The contacts 5, 7 and 18 are reversible, in that they are readily replaceable and can be readily disengaged and reengaged without tools. The contacts 5, 7 and 18 are typically  
15 either double-ended pins 24 or double-ended sockets 26. The wafer 12 can have pin and/or socket electrical connector contacts of varying sizes.

The wafer electrical connector contacts 18 are typically spaced apart across the wafer 12. The wafer 12 can have dissimilar contact patterns on opposed sides of the wafer 12.  
20 The wafer 12 can be configured in various contact densities and patterns.

The wafer 12 can also comprise EMI/EMC bonding mechanisms and can include environment sealing features.

25 The wafer 12 can be constructed to be an active device, such as a device capable of acting as a transducer, DiOD, capacitor or other electronic component, by attaching or embedding circuitry and/or electrical components therein.

30 The wafer 12 can be manufactured from various materials and can employ various dielectric materials.

The housing 14 is sized and dimensioned to accept and retain the wafer 12, the first flexible assembly 2 and the second flexible assembly 3. The first flexible assembly terminal end 4 is disposed adjacent to the first base side 20 of the wafer 14 and the second flexible assembly terminal end 6 is disposed adjacent to the second base side 22 of the wafer 14, such that each of the first flexible assembly electrical contacts 5 is removably secured and electrically connected to the first set of wafer electrical contacts 18a and each of the second flexible assembly electrical contacts 7 is removably secured and electrically connected to the second set of wafer electrical contacts 18b.

The housing 14 incorporates multiple entry and exit locations 28 for the flexible assemblies 2 and 3.

The housing 14 is typically stackable and comprises a base 30 and a top cover 32. The top cover 32 is secured to the base 30 by reversible fasteners. In the embodiment illustrated in the drawings, bores 34 are provided at each corner of the housing 14 to facilitate securing of the top cover 32 and the base 30 by bolts. Alternatively, the top cover 32 and the base 30 can be secured by nut and bolt pairs, clips, clamps or other equivalent reversible fasteners. Typically, the base 30 and the top cover 32 are made of interlocking construction for EMI and fire protection.

In the embodiment illustrated in the drawings, the housing 14 further comprises installation brackets 35.

The housing 14 can be made from a multitude of materials, including, but not limited to, aluminum, titanium, steel, plastic, PEEK and many different composite materials.

The housing 14 can be adapted to accommodate flexible assemblies having any shaped terminal end.

The housing 14 can also serve as an enclosure for various additional accessories, such as a mounting device.

The device 10 of the invention also typically comprises a double-ended grounding pad 38 and an interfacial seal 40.

The device 10 of the invention can also comprise gaskets 42 and/or grommets 44 to serve an array of functions, such as environmental sealing, EMI bonding, EMC bonding, vibration dampening and air volume reduction. The gaskets 42 can serve as a first spacer 42a and a second spacer 42b. The first spacer 42a is disposed between the housing 14 and the first flexible assembly 2 and the second spacer 42b is disposed between the housing 14 and the second flexible assembly 3.

It should be noted that the device can be adapted to electrically connect more than two flexible assemblies. For example, Figure 3 illustrates the electrical connection of a first flexible assembly 2, a second flexible assembly 3 and a third flexible assembly 8.

The device 10 of the invention employs no solder or other permanent, non-reversible connections with the terminal ends of the flexible assemblies 2 and 3.

Having thus described the invention, it should be apparent that numerous structural modifications and adaptations may be resorted to without departing from the scope and fair meaning of the instant invention as set forth hereinabove and as described hereinbelow by the claims.



**What is claimed is:**

1. A mechanical device for electrically connecting a first flexible assembly to a second flexible assembly, wherein the first flexible assembly comprises a first flexible assembly terminal end having a plurality of first flexible assembly electrical contacts and the second flexible assembly comprises a second flexible assembly terminal end having a plurality of second flexible assembly electrical contacts, the invention comprising:
- 5
- (a) a wafer comprising an insulator core and a plurality of wafer electrical connectors, the core having a first base side and an opposed second base side, the wafer electrical connectors comprising a first set of wafer electrical connector contacts exposed on the first base side and a second set of wafer electrical connector contacts exposed on the second base side, each electrical contact in the first set of wafer electrical connector contacts being electrically connected to a corresponding electrical contact in the second set of wafer electrical connector contacts, each wafer electrical connector contact being sized and
- 10
- dimensioned to electrically connect with a first flexible assembly electrical contact or a second flexible assembly electrical contact; and
- 15
- (b) a housing for accepting and retaining (i) the wafer, (ii) the first flexible assembly terminal end disposed adjacent to the first base side of the wafer, and (iii) the second flexible assembly terminal end disposed adjacent to the second base side of the wafer, such that each of the first flexible assembly electrical contacts is removably secured and electrically connected to the first set of wafer electrical connector contacts and each of the second flexible assembly electrical contacts is removably secured and electrically connected to the second set of wafer electrical connector contacts.
- 20
2. The device of claim 1 wherein the housing further comprises a first spacer and a second spacer, the first spacer being located between the housing and the first flexible assembly, and the second spacer being located between the housing and the second flexible assembly.
- 25
3. The device of claim 1 wherein the device further comprises grommets.
- 30
4. The device of claim 1 wherein the wafer electrical connectors are pins.

5. The device of claim 4 wherein the pins are spaced equally apart across the wafer.

5 6. The device of claim 4 wherein the plurality of first flexible assembly electrical contacts and the plurality of second flexible assembly electrical contacts are sized and dimensioned to electrically connect with the pins.

7. The device of claim 1 wherein the housing comprises a top cover and a bottom cover, the top cover being secured to the bottom cover by reversible fasteners.

10

8. The device of claim 1 comprising a hermetic glass insulator or other insulator disposed within the wafer between the first and second flexible assemblies, a circumferential double ended grounding pad for surrounding the terminal ends of both flexible assemblies and an interfacial seal.

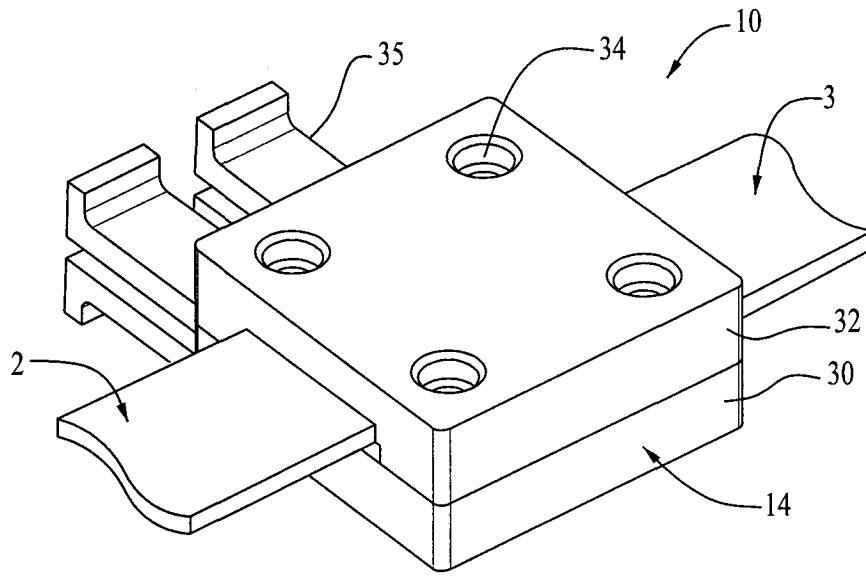

*FIG. 1*

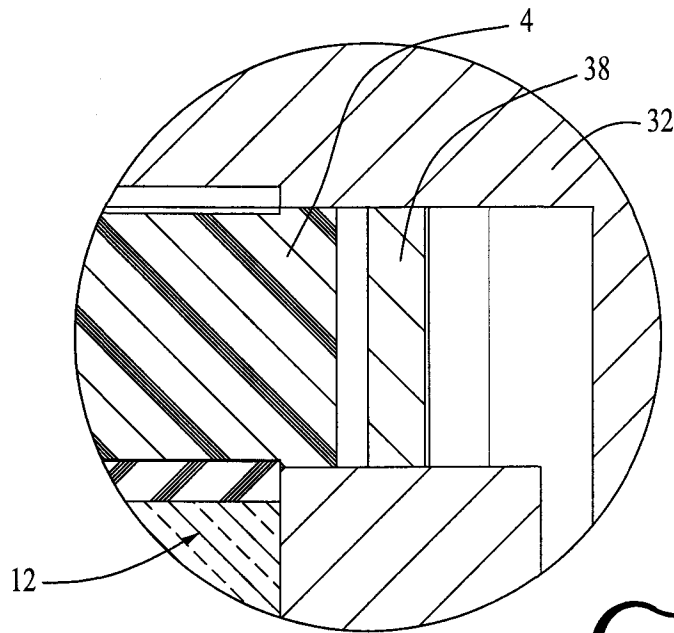

*FIG. 5*

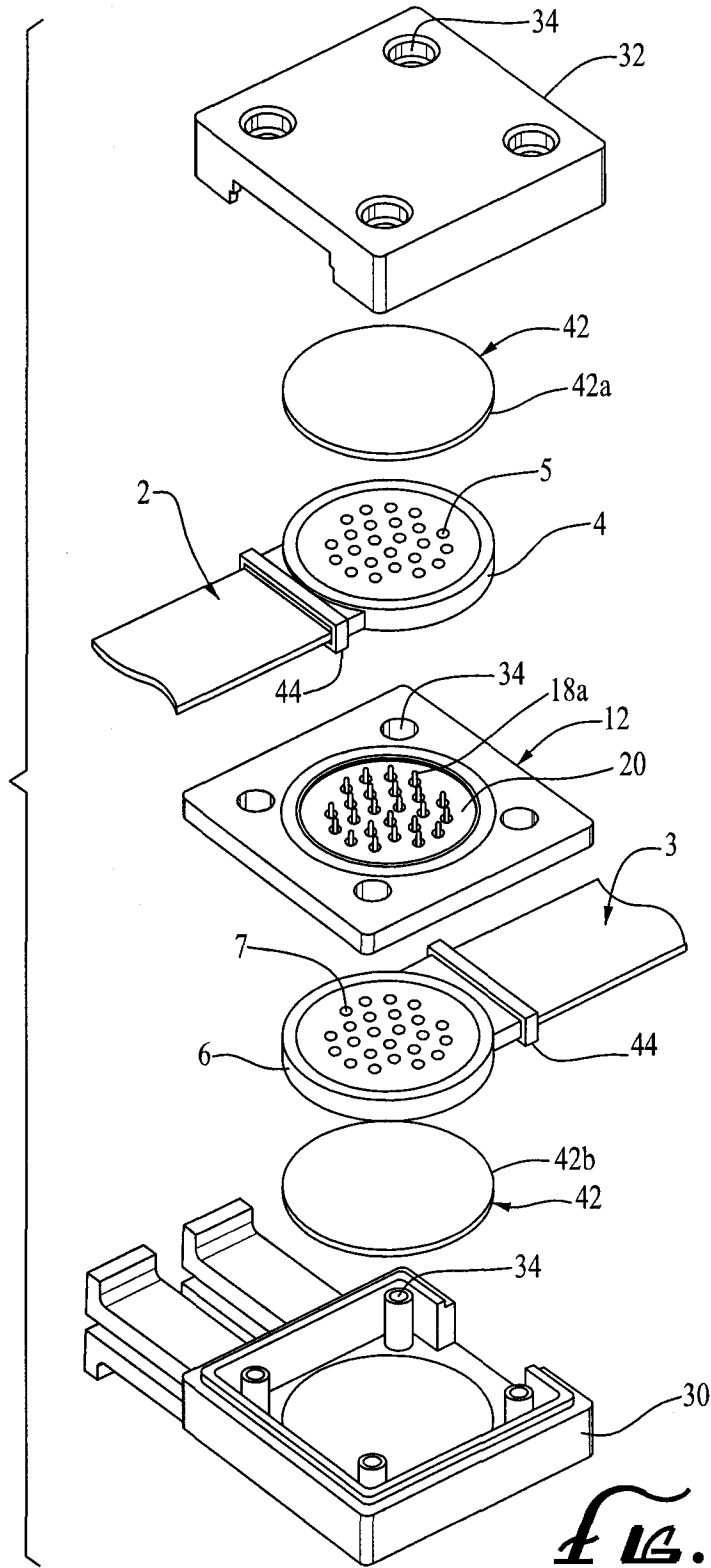

3/4

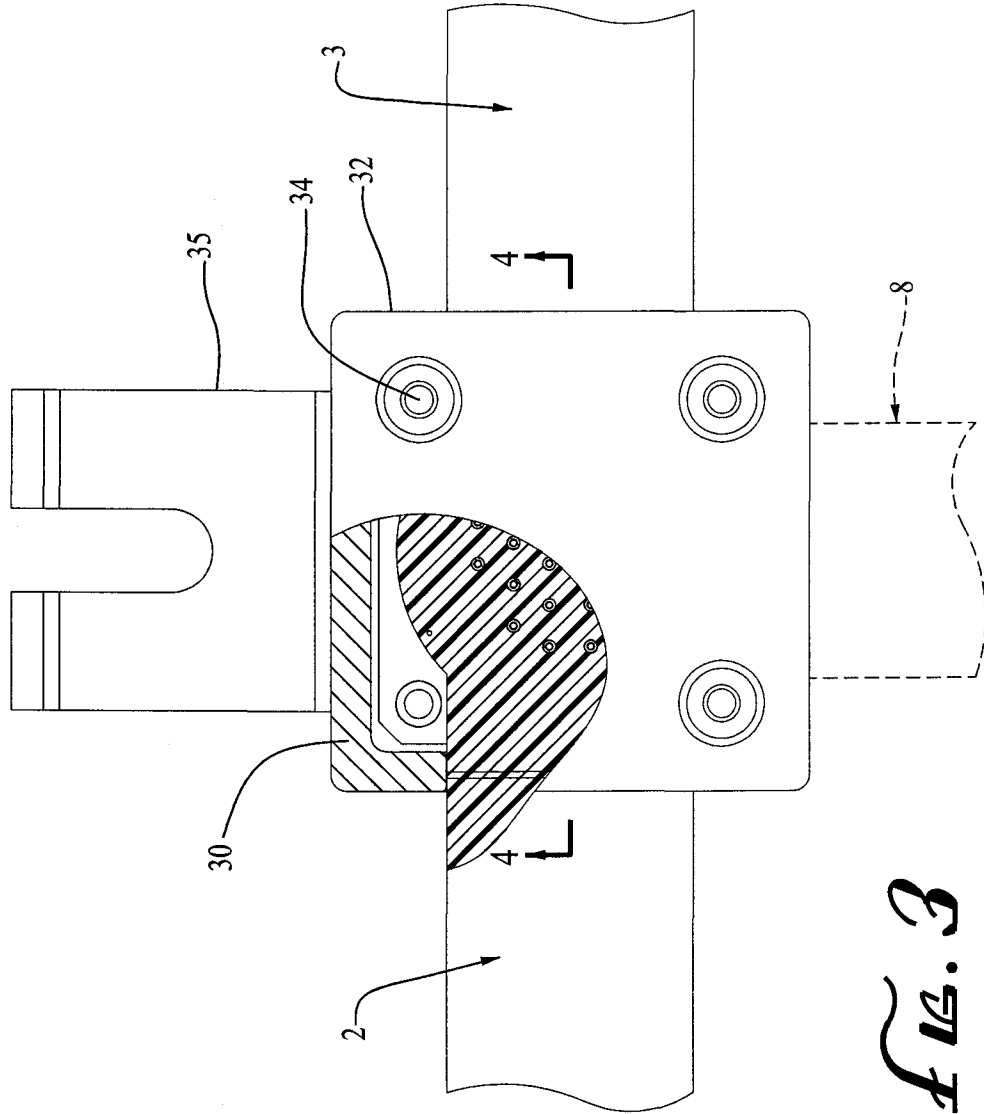

*FIG. 3*

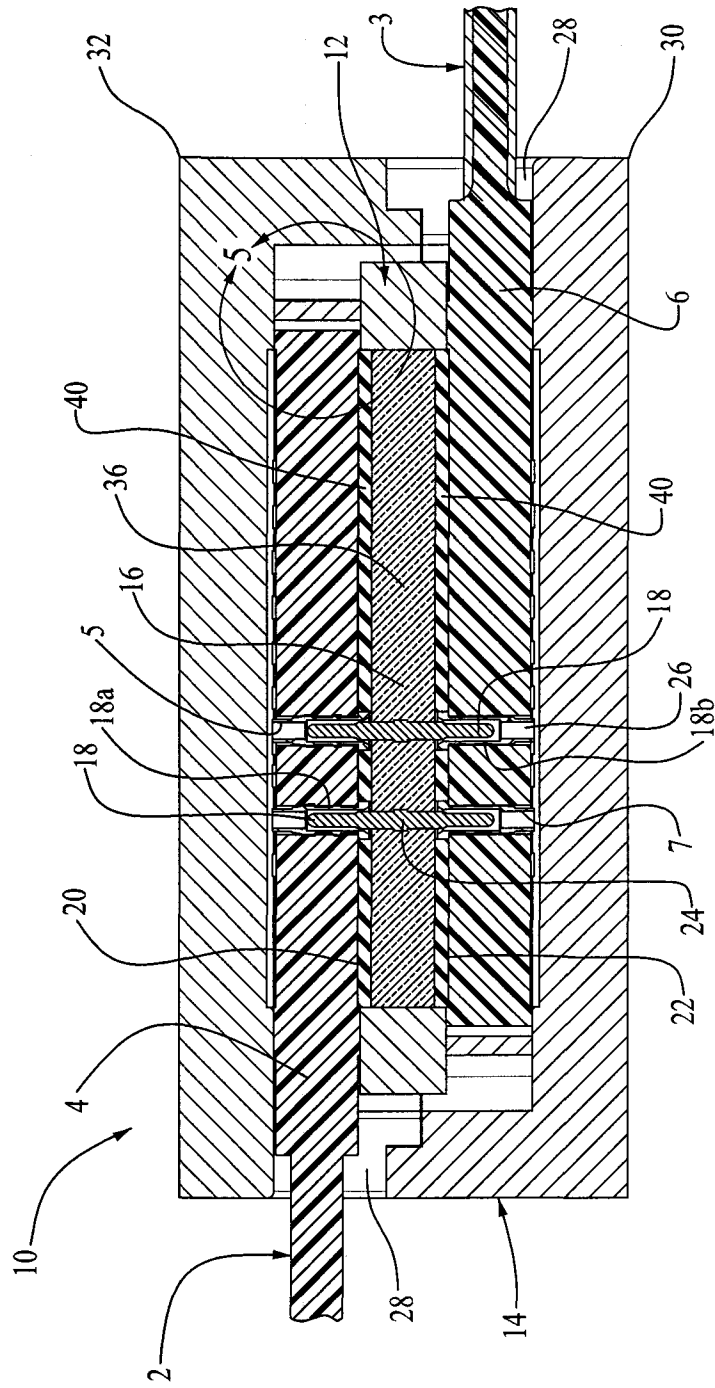

*FIG. 4*

**A. CLASSIFICATION OF SUBJECT MATTER*****H01R 12/59(2011.01)i, H01R 12/77(2011.01)i***

According to International Patent Classification (IPC) or to both national classification and IPC

**B. FIELDS SEARCHED**

Minimum documentation searched (classification system followed by classification symbols)

H01R 12/59; H01R 13/621; H01R 4/58; H01R 23/66; H02G 3/18; H01R 33/965; H05K 1/00; H05K 1/14; H01R 39/10

Documentation searched other than minimum documentation to the extent that such documents are included in the fields searched

Korean utility models and applications for utility models

Japanese utility models and applications for utility models

Electronic data base consulted during the international search (name of data base and, where practicable, search terms used)

eKOMPASS(KIPO internal) &amp; Keywords: connector, flexible, contact, pin, interconnect

**C. DOCUMENTS CONSIDERED TO BE RELEVANT**

Category*	Citation of document, with indication, where appropriate, of the relevant passages	Relevant to claim No.
Y	US 2003-0232524 A1 (ROBERT C. BURDICK) 18 December 2003 See abstract; paragraphs [0001]-[0008], [0025]-[0040]; and figures 1-8.	1-8
Y	US 04526432 A (CRONIN MICHAEL J. et al.) 02 July 1985 See abstract; column 3, line 44 &#8211; column 6, line 57; and figures 1-11.	1-8
Y	US 06064003 A (MOORE NATHAN J. et al.) 16 May 2000 See abstract; column 2, line 22 - column 3, line 35; and figures 1-5.	3
A	US 6721189 B1 (HABA BELGACEM) 13 April 2004 See abstract; column 5, line 64 - column 7, line 31; and figures 7A-8D.	1-8
A	US 05484294 A (SOBHANI MOHI) 16 January 1996 See abstract; column 2, line 46 - column 4, line 18; and figures 1-5.	1-8
A	US 04975068 A (SQUIRES JOHN J.) 04 December 1990 See abstract; column 4, line 4 - column 7, line 59; and figures 1-4.	1-8
A	US 2009-0149036 A1 (LEE KANG et al.) 11 June 2009 See paragraphs [0053]-[0110]; and figures 1,5-8D,16-24.	1-8

 Further documents are listed in the continuation of Box C. See patent family annex.

\* Special categories of cited documents:

"A" document defining the general state of the art which is not considered to be of particular relevance

"E" earlier application or patent but published on or after the international filing date

"L" document which may throw doubts on priority claim(s) or which is cited to establish the publication date of citation or other special reason (as specified)

"O" document referring to an oral disclosure, use, exhibition or other means

"P" document published prior to the international filing date but later than the priority date claimed

"T" later document published after the international filing date or priority date and not in conflict with the application but cited to understand the principle or theory underlying the invention

"X" document of particular relevance; the claimed invention cannot be considered novel or cannot be considered to involve an inventive step when the document is taken alone

"Y" document of particular relevance; the claimed invention cannot be considered to involve an inventive step when the document is combined with one or more other such documents, such combination being obvious to a person skilled in the art

"&amp;" document member of the same patent family

Date of the actual completion of the international search

22 NOVEMBER 2012 (22.11.2012)

Date of mailing of the international search report

**28 NOVEMBER 2012 (28.11.2012)**

Name and mailing address of the ISA/KR

Korean Intellectual Property Office  
189 Cheongsa-ro, Seo-gu, Daejeon Metropolitan  
City, 302-701, Republic of Korea

Facsimile No. 82-42-472-7140

Authorized officer

KIM, Sang Keol

Telephone No. 82-42-481-5742



**INTERNATIONAL SEARCH REPORT**

Information on patent family members

International application No.

**PCT/US2012/029957**

Patent document cited in search report	Publication date	Patent family member(s)	Publication date
US 2003-0232524 A1	18.12.2003	US 6758686 B2	06.07.2004
US 04526432 A	02.07.1985	None	
US 06064003 A	16.05.2000	EP 1071581 A1 EP 1071581 B1 WO 99-52743 A1	31.01.2001 17.09.2003 21.10.1999
US 6721189 B1	13.04.2004	US 2004-0229480 A1 US 2006-0114661 A1 US 7012812 B2 US 7417871 B2	18.11.2004 01.06.2006 14.03.2006 26.08.2008
US 05484294 A	16.01.1996	EP 0711003 A1 EP 0711003 B1 JP 02703527 B2 JP 08-213135 A JP 2703527 B2	08.05.1996 25.02.1998 03.10.1997 20.08.1996 26.01.1998
US 04975068 A	04.12.1990	EP 0431260 A1 EP 0431260 B1 JP 03-182075 A JP 07032040 B2 JP 1998409 C	12.06.1991 07.06.1995 08.08.1991 10.04.1995 08.12.1995
US 2009-0149036 A1	11.06.2009	AU 2006-276207 A1 AU 2006-276207 A1 AU 2006-276207 B2 AU 2006-276207 B2 AU 2006-276208 A1 AU 2006-276208 B2 AU 2006-291397 A1 AU 2006-291397 B2 CA 2632886 A1 CA 2632895 A1 CA 2632901 A1 EP 1952488 A2 EP 1958300 A2 EP 1994609 A2 EP 1994609 A4 US 2007-0025809 A1 US 2007-0026695 A1 US 2007-0026696 A1 US 2007-0105404 A1 US 2009-0117753 A1 US 2009-0149037 A1 US 7297002 B2 US 7335067 B2 US 7462035 B2	08.02.2007 08.02.2007 10.02.2011 10.02.2011 08.02.2007 29.04.2010 22.03.2007 27.05.2010 08.02.2007 22.03.2007 08.02.2007 06.08.2008 20.08.2008 26.11.2008 14.09.2011 01.02.2007 01.02.2007 01.02.2007 10.05.2007 07.05.2009 11.06.2009 20.11.2007 26.02.2008 09.12.2008



**INTERNATIONAL SEARCH REPORT**

Information on patent family members

International application No.

**PCT/US2012/029957**

Patent document cited in search report	Publication date	Patent family member(s)	Publication date
		US 7556532 B2	07.07.2009
		US 7658612 B2	09.02.2010
		US 7731517 B2	08.06.2010
		US 7753685 B2	13.07.2010
		WO 2007-015785 A2	08.02.2007
		WO 2007-015785 A3	14.06.2007
		WO 2007-015785 A3	08.02.2007
		WO 2007-015786 A2	08.02.2007
		WO 2007-015786 A3	08.02.2007
		WO 2007-032816 A2	22.03.2007
		WO 2007-032816 A3	22.03.2007