

No. 638,803.

Patented Dec. 12, 1899.

C. G. EDWARDS & C. E. PHELPS, JR.
VAULT FOR SUBTERRANEAN CONDUITS.

(Application filed Apr. 17, 1899.)

(No Model.)

2 Sheets—Sheet 1.

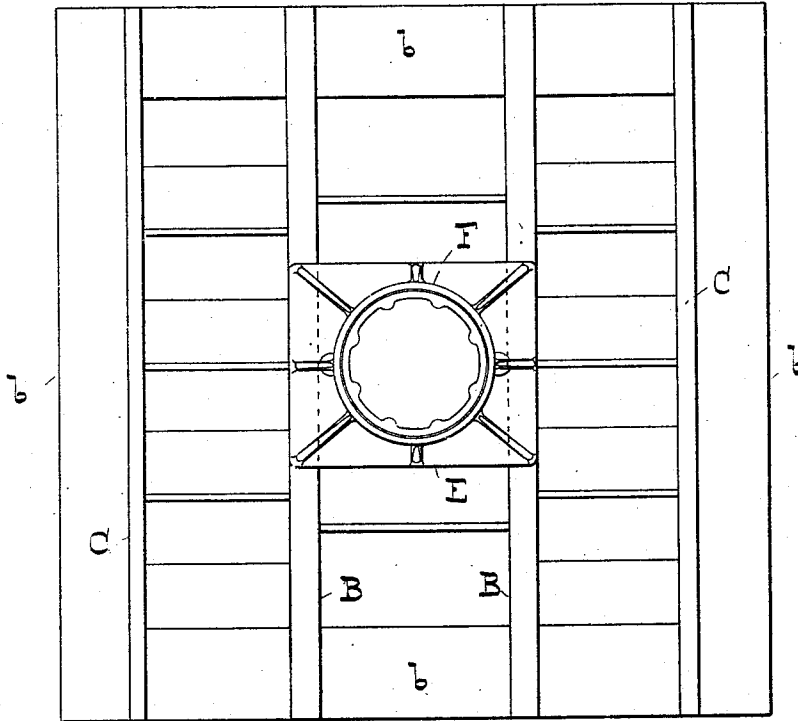

Fig. 1.

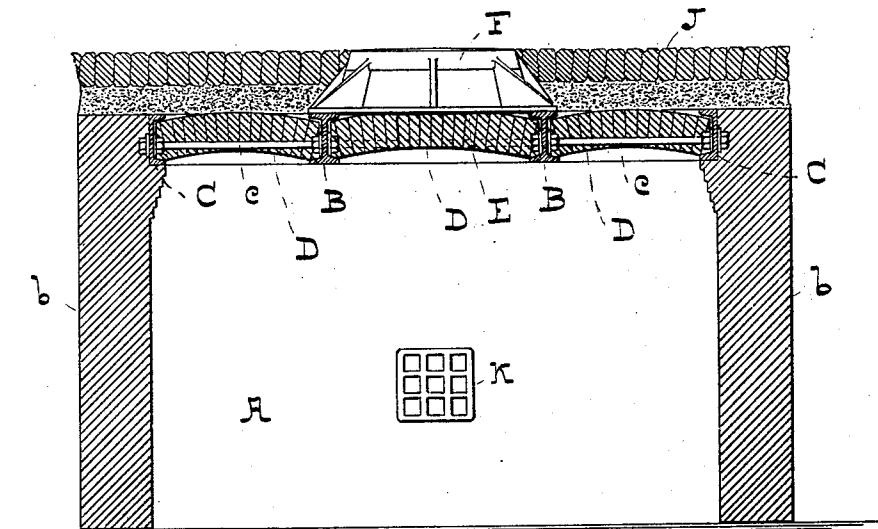

Fig. 2.

WITNESSES

Harry E. Fee,
Edward J. Dobson

INVENTORS

Charles G. Edwards,
Charles E. Phelps, Jr.,
by Wm. J. Howard, Atty.

No. 638,803.

Patented Dec. 12, 1899.

C. G. EDWARDS & C. E. PHELPS, JR.
VAULT FOR SUBTERRANEAN CONDUITS.

(Application filed Apr. 17, 1899.)

(No Model.)

2 Sheets—Sheet 2.

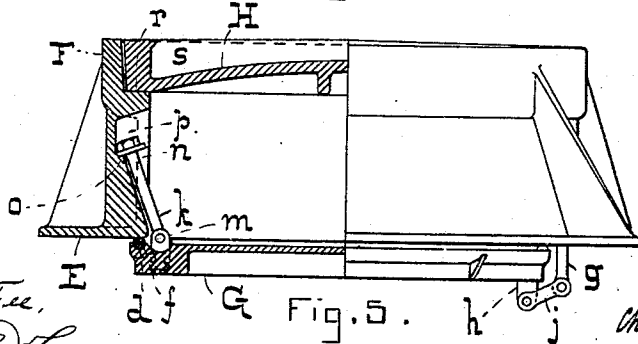
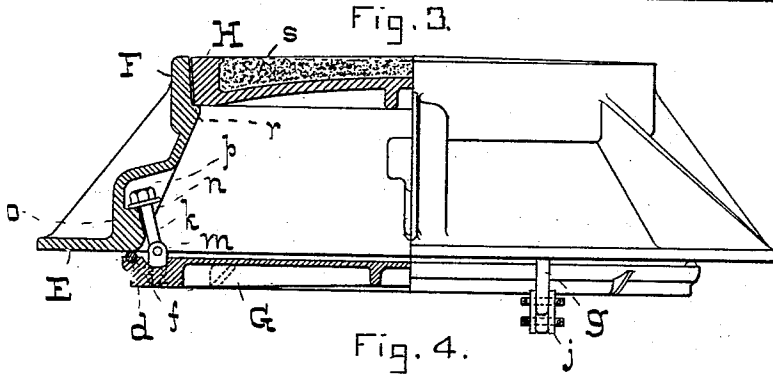
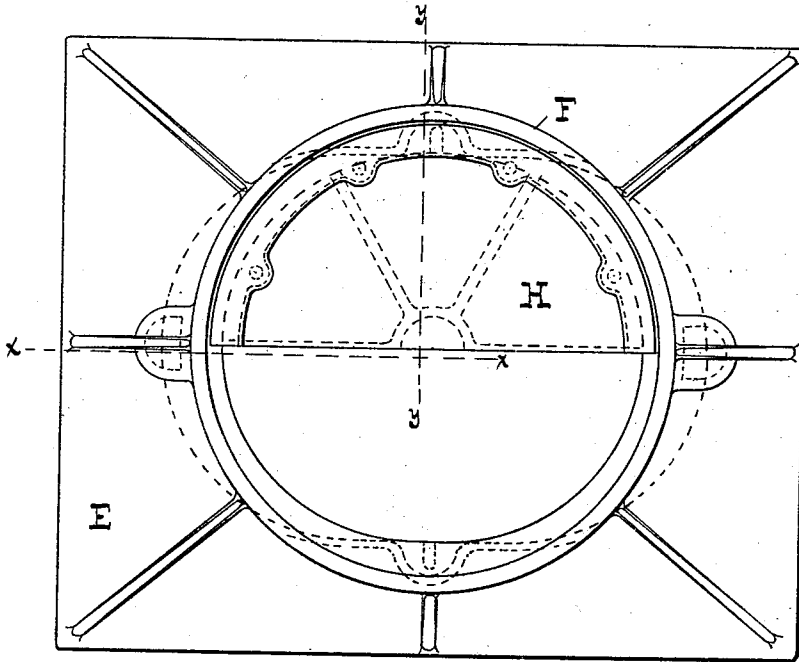

WITNESSES

Harry C. Lee,
Edgar A. DeLeon

INVENTORS

Charles G. Edwards,
Charles E. Phelps, Jr.,
by Wm. W. Howard,
att'y.

UNITED STATES PATENT OFFICE.

CHARLES G. EDWARDS AND CHARLES E. PHELPS, JR., OF BALTIMORE,
MARYLAND.

VAULT FOR SUBTERRANEAN CONDUITS.

SPECIFICATION forming part of Letters Patent No. 638,803, dated December 12, 1899.

Application filed April 17, 1899. Serial No. 713,231. (No model.)

To all whom it may concern:

Be it known that we, CHARLES G. EDWARDS and CHARLES E. PHELPS, Jr., of the city of Baltimore, in the State of Maryland, have invented certain Improvements in Vaults for Subterranean Conduits, of which the following is a specification.

This invention relates to the peculiar formation of the manhole-plates and their frames used in the construction of vaults which give access to subterranean conduits for electric-light, telephone, and other wires, as will hereinafter fully appear.

In the description of the said invention which follows reference is made to the accompanying drawings, forming a part hereof, and in which—

Figure 1 is a plan of the vault, together with the framework and manhole appliances which cover it. Fig. 2 is a vertical central section of the vault with the frame for the manhole-plates in full. Fig. 3 is an enlarged top view of the manhole-plate frame and one-half of the upper plate. Fig. 4 is a half-section of Fig. 3 taken on the dotted line xx . Fig. 5 is a half-section of Fig. 3 taken on the dotted line yy .

Referring now to the drawings, A is the vault, and $b b$ are the walls thereof.

B B are I-beams, and C C are channel-plates built in the walls b and tied together by bolts c .

D D are brick arches supported by the I-beams and channel-plates.

The I-beams sustain the frame for the manhole-plates, which consist of a foundation-plate E, having a hollow body or shell F, which is elliptical at its base, or where it adjoins the base-plate, and circular at the top. The interior of the shell constitutes the manhole through which access is had to the vault A.

An ordinary ladder is used as means to reach the bottom of the vault, and it is placed so that its upper end will rest against the inner surface of the wall of the frame. The upper end of the ladder consequently reduced the effective opening in the lower part of the frame, and if the manhole is made cylindrical its diameter has to be much greater than that actually required for the passage of the body of a man. We obviate the difficulty by mak-

ing the manhole at the lower end of the frame elliptical or oval, or, in other words, with recesses or extensions to receive the upper end of the ladder, and the said recesses are placed diametrically opposite each other, so that either recess may be used. The frame may therefore be much smaller and of less weight than one having a cylindrical hole of the same effective size.

G is the manhole-plate, applied to the under side of the frame to prevent surface water entering the vault. It is provided with a peripheral groove d , in which a gasket f is placed to form a tight joint, and is hinged to the frame at one side of the manhole. The hinges consist of studs g , projecting from the bottom of the frame, similar studs h on the plate, and connecting-links j . This description of hinge is well adapted for the purpose, for the reason that it does not prevent the plate being drawn up equally at all points in its circumference, by means of bolts hereinafter referred to. The plate G when closed is secured by means of bolts k , hinged to the bars m , cast in the plate G, which pass through slots n in lugs o , situated in pockets p , formed in the wall of the frame and situated exteriorly of its inner circumference. By placing the lugs o exteriorly of the inner circumference of the manhole, as described, there are no obstructing parts to interfere with a person passing through the manhole.

H is the circular upper manhole-plate, which rests on an annular shoulder r within the frame. It is preferably dished, as seen from the under side, and ribbed, and the recess s at the upper side is filled with asphalt, concrete, or some other suitable paving material.

The frame is not necessarily secured to the I-beams, as it is held by the surrounding street-pavement J, which in the present case consists of blocks laid on concrete.

In Fig. 2 a wire-conduit (denoted by K) is shown as entering the vault.

We claim as our invention—

1. A manhole-plate frame for the purpose described, the wall of which is circular at the top and elliptical at the bottom whereby recesses are formed at points diametrically opposite, substantially as specified.

2. In combination with a manhole-plate frame, a plate hinged to the under side of the frame and held thereto by means of bolts, substantially as specified.
- 5 3. In combination with a manhole-plate frame, a plate hinged to the under side thereof by means of link-hinges, and secured by bolts, substantially as specified.
- 10 4. In a manhole-plate frame for the purpose described, the wall thereof provided with pockets which are exterior of the inner circumferential line of the wall, and lugs in the pockets which are slotted to receive holding-bolts of a plate situated below the said frame,
- 15 substantially as specified.

5. In combination with a frame for manhole-plates, having pockets situated exteriorly of the inner surface of the hole, and slotted lugs, within the said pockets, substantially as described, a plate hinged to the under side of the frame having hinged bolts adapted to be swung through the slots in the lugs into the said pockets and held thereat by nuts, substantially as specified.

CHARLES G. EDWARDS.
CHARLES E. PHELPS, JR.

Witnesses:

WM. T. HOWARD,
HARRY E. FEE.