

(19) World Intellectual Property Organization
International Bureau



(43) International Publication Date
21 July 2011 (21.07.2011)

(10) International Publication Number
WO 2011/088398 A1

- (51) International Patent Classification:
G01N 15/14 (2006.01) *G02B 21/34* (2006.01)
- (21) International Application Number:
PCT/US2011/021403
- (22) International Filing Date:
14 January 2011 (14.01.2011)
- (25) Filing Language: English
- (26) Publication Language: English
- (30) Priority Data:
61/295,492 15 January 2010 (15.01.2010) US
61/378,160 30 August 2010 (30.08.2010) US
- (71) Applicant (for all designated States except US): **PRESIDENT AND FELLOWS OF HARVARD COLLEGE** [US/US]; 17 Quincy Street, Cambridge, MA 02138 (US).
- (72) Inventors; and
- (75) Inventors/Applicants (for US only): **COHEN, Adam, E.** [US/US]; 43 Linnaean Street, #45, Cambridge, MA 02138 (US). **LESLIE, Sabrina, R.** [CA/US]; 381 Harvard Street, #22, Cambridge, MA 02138 (US).
- (74) Agents: **SCOZZAFAVA, Mary, Rose** et al.; Wilmer Cutler Pickering Hale And Dorr LLP, 60 State Street, Boston, MA 02109 (US).

(81) Designated States (unless otherwise indicated, for every kind of national protection available): AE, AG, AL, AM, AO, AT, AU, AZ, BA, BB, BG, BH, BR, BW, BY, BZ, CA, CH, CL, CN, CO, CR, CU, CZ, DE, DK, DM, DO, DZ, EC, EE, EG, ES, FI, GB, GD, GE, GH, GM, GT, HN, HR, HU, ID, IL, IN, IS, JP, KE, KG, KM, KN, KP, KR, KZ, LA, LC, LK, LR, LS, LT, LU, LY, MA, MD, ME, MG, MK, MN, MW, MX, MY, MZ, NA, NG, NI, NO, NZ, OM, PE, PG, PH, PL, PT, RO, RS, RU, SC, SD, SE, SG, SK, SL, SM, ST, SV, SY, TH, TJ, TM, TN, TR, TT, TZ, UA, UG, US, UZ, VC, VN, ZA, ZM, ZW.

(84) Designated States (unless otherwise indicated, for every kind of regional protection available): ARIPO (BW, GH, GM, KE, LR, LS, MW, MZ, NA, SD, SL, SZ, TZ, UG, ZM, ZW), Eurasian (AM, AZ, BY, KG, KZ, MD, RU, TJ, TM), European (AL, AT, BE, BG, CH, CY, CZ, DE, DK, EE, ES, FI, FR, GB, GR, HR, HU, IE, IS, IT, LT, LU, LV, MC, MK, MT, NL, NO, PL, PT, RO, RS, SE, SI, SK, SM, TR), OAPI (BF, BJ, CF, CG, CI, CM, GA, GN, GQ, GW, ML, MR, NE, SN, TD, TG).

Published:

- with international search report (Art. 21(3))
- before the expiration of the time limit for amending the claims and to be republished in the event of receipt of amendments (Rule 48.2(h))

(54) Title: CONVEX LENS-INDUCED CONFINEMENT FOR MEASURING DISTRIBUTIONS OF MOLECULAR SIZE

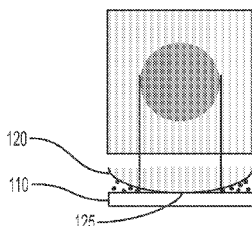

FIG. 3A

(57) Abstract: A curved surface is placed tangent to a slide and displaces a sample liquid from the point or line of contact outward. Imaging indicates a region where fluorescence is observed, and the location of the fluorescence indicates the molecular size. The radius of curvature of the lens is known, the distance from the (center) point of contact of the observed fluorescence is measured with a microscope and the distance of the lens surface to the slide's surface can then be calculated. This distance represents the size of the molecule or ensemble of molecules emitting. Similarly, absorbance, etc. could be measured with a light source below the slide.



WO 2011/088398 A1

CONVEX LENS-INDUCED CONFINEMENT FOR MEASURING DISTRIBUTIONS OF MOLECULAR SIZE

Statement of Government Rights

[0001] This invention was made with government support under CHE-0910824 awarded by the National Science Foundation. The government has certain rights in the invention.

Incorporation By Reference

[0002] All patents, patent applications and publications cited herein are hereby incorporated by reference in their entirety in order to more fully describe the state of the art as known to those skilled therein as of the date of the invention described herein.

Related Applications

[0003] This application claims priority to co-pending United States Provisional Application No. 61/295,492, filed January 15, 2010, and U.S. Provisional Application No. 61/378,160, filed August 30, 2010. The contents of those applications are incorporated by reference.

Background

[0004] The subject matter is directed to systems and methods for determining the size of a molecule, or, more generally, the distribution of sizes of an ensemble of molecules.

[0005] Gel electrophoresis is the most commonly used technique for measuring distributions of molecular sizes. In its usual application to proteins, the proteins are denatured so the electrophoretic mobility measures the molecular length, and thereby the approximate molecular weight. Native gel electrophoresis can also be applied to biomolecules in their functional conformation, though the interpretation of mobilities in native gels is often ambiguous. Gel electrophoresis cannot be applied to large or weakly associating molecular complexes. Additionally, gel electrophoresis typically requires several hours to run, requires large amounts of sample, and consumes ~100 mL of reagents.

[0006] The sizes of particles larger than ~10 nm diameter can be determined by dynamic light scattering (DLS). All particles scatter light, so dust or impurities confound or interfere with DLS measurements, and DLS can only be applied to the major component in a

heterogeneous mixture. Furthermore, the inverse Laplace transform used in interpretation of DLS is subject to noise, so DLS measurements are often imprecise.

[0007] Fluorescence correlation spectroscopy (FCS) measures the size of fluorescent species in solution by measuring the distribution of residence times in a focused laser spot. FCS works best for small molecules, with hydrodynamic radii of less than 20 nm. As with DLS, FCS cannot easily distinguish between individual particles and fluorescent aggregates. FCS provides only a very coarse measure of molecular size, and is not well suited to measuring heterogeneous size distributions.

Summary

[0008] A simple system that measures the size and/or size distributions of imageable molecules in solution is provided. The present system and method provide means to determine the size of a molecule, or more generally, the size distribution of a population of molecules.

[0009] In one aspect, a system for detecting the size of a molecule is provided. The system includes a sample measurement surface having a curved cover plate positioned tangent to a planar surface, e.g., there is a single point or line of contact, and the curved cover plate has a surface that varies in a predetermined and understood manner from the point of contact to a radially displaced position relative to the point of contact. The system also includes an imaging system such as an inverted fluorescent microscope. The system is capable of detecting molecules in solution, with molecular diameters in the size range of ~2 – 1000 nm. The imaging system is capable of detecting molecules, e.g., either by absorption, by fluorescence or other technique. The transparent material can be wedged shaped or curvilinear. By way of example, it can be a convex, biconvex, plano-convex lens, or concave convex lens where the curvature of the surface is well-defined.

[0010] In one aspect, a method for detecting the size of a molecule is provided. The method includes applying a test liquid containing molecules to be measured to the sample measurement surface. Measuring the location of the fluorescence from the point of contact, wherein the location of fluorescence is an indication of the molecular size. Similarly, other properties of the sample, absorbance, etc. could be measured with a light source below the sample measurement surface to determine onset of molecular exclusion.

[0011] The radius of curvature of the transparent material is known. The distance from the (center) point of contact to the observed fluorescence is measured and the distance (or spacing) of the curved surface to the planar surface can then be calculated. This distance correlates with the size of the molecule or collection of molecules. The phenomenon of excluding particles from regions under the curved surface that are smaller than the molecular diameter is referred to as “nanoscale confinement.”

[0012] The system for detecting the size of a molecule can operate with low analyte amounts, e.g., ~10 μ L of a ~1 nM solution of analyte, acquires the data in ~1 minute, works in the presence of a high concentration of non-fluorescent background, and is simple to construct and operate.

[0013] The methodology can be used to determine the sizes of freely diffusing molecules with diameters ranging from 2 nm to 1000 nm by imaging their areal density as a function of the nanoscale confinement. For example, the method and device can be used to detect the molecular size of biomolecules such as proteins, micelles and DNA. It can also be used to detect the molecular size of polymers, in particular polymer beads. The methodology is suited to measuring the size of a homogeneous sample population as well as the size distribution of a heterogeneous sample population.

[0014] A simple method for imaging single molecules in free solution is disclosed. The system confines molecules in a nanoscale wedge-shaped gap formed between a curved surface and a planar surface. The sub-wavelength confinement leads to up to 20-fold greater rejection of background fluorescence than is achieved with total internal reflection fluorescence (TIRF) imaging, and approximately 10,000-fold longer per-molecule observation time than is achieved with confocal detection. The system provides information relating to the nanoscale optical and mechanical properties of single molecules, without relying on nanofabrication or nanopositioning equipment.

[0015] The system for detecting size of a molecule includes a sample measurement surface having a convex surface positioned tangent to a planar surface, coupled with an imaging system such as an inverted fluorescent microscope. In one or more embodiments, the convex surface comprises a lens and the system is referred to as a convex lens-induced confinement system (CLIC). In one or more embodiments, the system comprises a flow cell having two

substantially planar surfaces, one of which can be deflected to form a convex surface, and the system is referred to as a flow cell-convex lens-induced confinement system (FC-CLIC).

[0016] In one aspect, a method for detecting size of a molecule, includes applying a liquid sample containing molecules to be measured to a sample measurement surface; contacting the sample measurement surface with a curved surface positioned tangent to the sample measurement surface at a point or line of contact, said curved surface having a surface that varies in a predetermined and understood manner from the point or line of contact to a displaced position relative to the point or line of contact; subjecting the sample to imaging to identify a region where sample is present; and determining the location of the sample presence from the point of contact outward, wherein the location of the sample is an indication of molecular size.

[0017] In one or more embodiments, the imaging detects fluorescence, or the imaging detects light absorbance.

[0018] In any of the preceding embodiments, the curved surface includes a convex lens, and for example, the convex surface is selected from the group consisting of convex, biconvex, plano-convex, and concave convex lenses, or the curved surface comprises a cylindrical lens.

[0019] In any of the preceding embodiments, the curved surface is obtained by deflecting a flexible sheet disposed above the sample measurement surface into contact with the sample measurement surface.

[0020] In any of the preceding embodiments, the method further includes correlating the location of the fluorescence with a distance of the lens surface to the planar surface, said distance representing a molecular dimension of the molecules.

[0021] In any of the preceding embodiments, molecule size is determined, or molecule size distribution is determined, or molecular aspect ratio is determined.

[0022] In any of the preceding embodiments, fluorescent imaging provides a gradual transition from a dark region to a bright fluorescence region.

[0023] In any of the preceding embodiments, molecular aspect ratio is determined.

[0024] In any of the preceding embodiments, the molecular size ranges from about 2 nm to about 1000 nm.

[0025] In any of the preceding embodiments, the sample measurement surface comprises a flow cell having an upper and a lower surface for receiving a sample to be measured, and the convex surface is provided by deflecting the upper surface of the flow cell downward to the lower surface of the flow cell to create the contact point.

[0026] In any of the preceding embodiments, the method further includes coating the convex surface and/or the sample measurement surface with a non-stick coating.

[0027] In any of the preceding embodiments, the molecule is a biomolecule, for example, proteins, micelles or DNA, or a polymer molecule, for example, polymer beads.

[0028] In any of the preceding embodiments, the sample measurement surface and/or the curved surface comprises surface features, and for example, the surface features are selected from the group of dimples and posts.

[0029] In another aspect, a system for detecting size of a molecule, includes a sample measurement zone having a convex surface positioned tangent to a planar surface, coupled with an inverted fluorescent microscope positioned to detect the presence of a molecule of interest in the sample measurement zone.

[0030] In another aspect, a system for detecting size of a molecule, includes a sample measurement zone having a convex surface positioned tangent to a planar surface, coupled with an imaging device capable of detecting the presence of a molecule of interest present in the sample measurement zone.

[0031] In any of the preceding embodiments, the imaging device is capable of detecting light absorbance or fluorescence.

[0032] In any of the preceding embodiments, the molecule of interest is a biomolecule, for example, proteins, micelles or DNA, or a polymer molecule, for example, polymer beads.

[0033] In any of the preceding embodiments, comprising a translation stage for positioning the convex surface in the x-, y-, and z-directions.

[0034] In any of the preceding embodiments, the convex surface comprises a convex lens, and for example, the convex surface is selected from the group consisting of convex, biconvex, plano-convex, and concave convex lenses.

[0035] In any of the preceding embodiments, the lens is coupled with a counterweight to reduce the resting force of the lens on the planar surface.

[0036] In any of the preceding embodiments, the convex surface is coated with an anti-stick coating.

[0037] In any of the preceding embodiments, the sample measurement zone comprises a flow cell for receiving a sample to be measured, said flow cell comprising upper and lower sheets spaced apart from one another a distance defined by side walls.

[0038] In any of the preceding embodiments, the system further includes a deflector, positioned above the flow cell, for reversibly deflecting the upper surface of the flow cell into contact with the lower surface of the flow cell to form the convex surface of the sample measurement zone.

[0039] In any of the preceding embodiments, the system further includes a translation stage for positioning the convex surface in and out of deformation contact with the flow cell.

[0040] In any of the preceding embodiments, the width of the flow cell varies along its length.

[0041] In any of the preceding embodiments, the system further includes imaging software or particle tracking software.

[0042] In another aspect, a method for detecting size of a molecule, includes applying a liquid sample containing molecules to be measured to a sample measurement zone, the sample measurement zone having a transparent material positioned tangent to a planar surface, said material having a surface that varies in a predetermined manner from the point of contact to a radially displaced position relative to the point of contact; subjecting the sample to fluorescent imaging to identify a region where the fluorescence is observed; and determining the location of the fluorescence relative to the point of contact, wherein the location of the fluorescence is an indication of molecular size.

[0043] In any of the preceding embodiments, the transparent material is wedge-shaped.

[0044] In any of the preceding embodiments, the transparent material is curvilinear.

Brief Description of the Drawings

[0045] Various objects, features, and advantages of the present invention can be more fully appreciated with reference to the following detailed description of the invention when considered in connection with the following drawings, in which like reference numerals identify like elements. The following drawings are for the purpose of illustration only and are not intended to be limiting of the invention, the scope of which is set forth in the claims that follow.

[0046] Figure 1 is a schematic illustration of a convex-lens induced confinement system according to one or more embodiments.

[0047] Figure 2 is a photograph of a convex-lens induced confinement system according to one or more embodiments.

[0048] Figure 3 is schematic illustration demonstrating the determination of molecular size for (a) a low aspect molecule and (b) a high aspect molecule.

[0049] Figure 4 illustrates normalized fluorescence profiles of solutions (Concentration = 1.4 nM) of two lengths of linear DNA, pUC19 (2.7 kbp) (large dot) and ϕ X174 (5.4 kbp) (small dot), and free Alexa 647 dye (Concentration = 50 nM). Linear fits to these profiles are performed at large gap heights ($0.6 \mu\text{m} < h < 2.7 \mu\text{m}$). The fluorescence profiles have been normalized to have equal slopes in this region.

[0050] Figure 5 shows the signal-to-background ratio as a function of confinement (displacement from contact point), for CLIC imaging of surface-immobilized fluorescent polystyrene beads immersed in 50 nM Alexa 647 dye.

[0051] Fig. 6 shows a CLIC image of surface-tethered DNA oligonucleotides in the presence of 0.2 μM Alexa 647 dye, imaged with a power of 6 mW and exposure time of 0.1 s. A nonlinear contrast scale is applied to permit visualization in the same image of the single molecules at small radius from the point of contact and the background fluorescence at large radius from the point of contact.

[0052] Fig. 7 shows a photobleaching timetrace of a single DNA molecule (circled in Figure 6).

[0053] Fig. 8 shows CLIC images of free dye (Alexa 647) and surface-tethered DNA oligonucleotides at dye concentrations of 0.2 μM , 1 μM , and C=2 μM , with equal-fluorescence contours indicated. A linear contrast is used.

[0054] Fig. 9 is a schematic illustration of a flow cell CLIC system according to one or more embodiments in which the convex lens is in a (A) raised or (B) lowered position.

[0055] Fig. 10 is a schematic illustration of a flow cell according to one or more embodiments.

[0056] Fig. 11 is a photograph of an exemplary flow cell CLIC system.

Detailed Description

[0057] The Convex (or Cylindrical) Lens-Induced Confinement (CLIC) or the flow cell Convex (or Cylindrical) Lens-Induced Confinement system (FC-CLIC) system determines the distribution of molecular sizes by measuring the density profile of molecules confined in a wedge-shaped gap. Molecules are excluded from regions where the height of the gap is less than the diameter of the molecule. Under imaging conditions, a dark region is observed where molecules are excluded due to their size. A fluorescent image centered on the point of contact shows a disk inside of which there is no fluorescence. A bright area is observed outside the disk where molecules are located. Although this method is described using fluorescence as the imaging mode, other imaging or detection techniques can be implemented within the scope of the method. For example, the method can be used with any optical microscopy technique that can be performed in an inverted microscope. Exemplary fluorescence microscopy imaging techniques include epifluorescence, total internal reflection fluorescence (TIRF), confocal, and two-photon microscopy, for example. In addition, the method can be used with differential interference contrast (DIC), dark-field, Raman, and coherent anti-Stokes Raman (CARS) microscopy.

[0058] The CLIC or FC-CLIC device provides a direct measure of the diameter of imageable molecules in solution, offering a dynamic range of 2 nm to 3 μm , or 2 nm to 1000 nm, and handling freely diffusing molecules in their native form. Measurements require only

10 μL of solution at an analyte concentration of only 1 nM, and may be performed in less than one minute.

[0059] The CLIC or FC-CLIC device employs wedged shaped or curvilinear surface to generate a surface that varies in its distance in a known manner from a planar surface on which it is disposed. In one or more embodiments, the curvilinear surface can be a convex, biconvex, plano-convex lens, or concave convex lens where the curvature of the surface is well-defined. When the lens is placed in contact with a planar surface, it forms a point contact. In other embodiments, the curvilinear surface can be a cylindrical lens. A cylindrical lens is a lens which focuses light which passes through on to a line instead of on to a point, as a spherical lens would. The curved face or faces of a cylindrical lens are sections of a cylinder. When the lens is placed in contact with a planar surface, it forms a line contact.

[0060] In one embodiment, the CLIC system includes a plano-convex lens, curved side down, resting on top of a coverslip or other flat, transparent surface. See, e.g., Figure 3(a). Due to the curved nature of the lens surface, it contacts the flat surface at a single point. The region near the point of contact between the lens and the coverslip is imaged using an inverted fluorescence microscope. The lens-coverslip distance varies smoothly from zero at the point of contact, to hundreds of microns at radii far from the point of contact, according to the equation:

$$h \approx \frac{1}{2} \frac{r^2}{R},$$

[0061] where r is the distance from the point of contact and R is the radius of curvature of the lens. Near the point of contact, a displacement of tens of microns in the x - y plane leads to a nanometer-scale change in the thickness of the gap. In a typical field of view of 100 μm , with a 100 mm focal length lens ($R = 4.6$ cm), the gap varies from 0 to 27 nanometers. From the radius of the excluded region, r , and the known radius of curvature of the lens, R , one can extract the diameter of the molecules, h . This measurement has an accuracy of ~ 2 nm. Locations and measurements of imaged particles can be accomplished using conventional methods. By way of example, three-dimensional particle tracking is described by Peterson et al., in Meas. Sci. Technol. **19** (2008) 115406, which is incorporated in its entirety by reference. Similar relationships are found for the convex surface generated in FC-CLIC, where the convex surface is generated using deflection of a flexible planar surface.

[0062] The accuracy of the confinement is determined, in part, by how well the curvature of the lens is known. This curvature can be measured to high accuracy *in situ* using optical interferometry. The precision of the *confinement* is a function of the surface roughness of the lens and the coverslip. The surfaces should be relatively smooth. Fused silica optics are commercially available with root mean square (RMS) surface roughness < 1 nm. To accurately detect the confinement of molecules in the resulting gap, the sheets should be flat on the length scales of the molecules of interest. Typically, the sheets have a RMS surface roughness less than about 1 nm. Acceptable ranges of surface roughness depend on the size of the molecules to be measured: for a molecule of diameter x , the surface roughness should be less than $x/3$ or more preferably less than $x/5$ or most preferably less than $x/10$. In some embodiments, the surface can be patterned, for example by lithography. Surface features can provide a further level of molecular confinement. For example, a surface can include an array of posts or dimples. The posts constrain the molecules between posts in addition to the constraint based upon the radius of curvature of the convex surface.

[0063] In a substantially monodisperse population, molecules will distribute uniformly throughout the liquid sample due to Brownian motion. However, the molecules will be physically excluded from areas under the lens where the gap is less than the molecule dimension. For a uniformly sized population of molecules, there is a fairly abrupt cutoff of fluorescence. See, Fig. 3(a). The system determines the distribution of molecular sizes directly by measuring the density profile of molecules confined in a wedge-shaped gap. Simply, molecules are excluded from regions in which the gap height is less than the molecular diameter. In considering an idealized sample of hard spheres, a fluorescent image centered on the point of contact shows a disk inside of which there is no fluorescence (Fig 3a). In a heterogeneous population of real molecules, the cutoff is gradual, and the shape of the cutoff indicates the distribution of molecular sizes.

[0064] The CLIC and FC-CLIC systems also allow one to learn about the aspect ratio of anisotropic particles. For rodlike particles, for instance, there is an entropic penalty to enter the region where there is orientational confinement, but the particles are not completely excluded until the confinement is less than the *diameter* of the rod. Fig. 3(b) illustrates the various orientations of an aspected particle 300 in the area under the lens a distance away from the central point of contact. By measuring the profile of particle density as a function of confinement, one can extract information about the length and aspect ratio of an asymmetric

object. Such a technique is well suited to determine the size and shape of virus particles or amyloid fibrils, for example.

[0065] In a heterogeneous population of molecules, molecules of different sizes occupy different locations in the gap. Since molecules are excluded from regions in which the gap height is less than the molecular diameter, larger molecules are excluded at a greater distance from the contact point. Since molecules are expected to randomly distribute throughout the area where the gap height is greater than molecule dimension, the resulting cutoff of fluorescence is gradual, and the shape of the cutoff indicates the distribution of molecular sizes.

[0066] The distribution of molecules and their size can be extracted from the pattern of fluorescence intensity using available imaging software. Fluorescence images are loaded into analysis software, bright regions are identified as fluorescent molecules and their spatial density profile is determined. In addition, particle tracking software can be employed to characterize their diffusion.

[0067] An apparatus according to one or more embodiments for the determination of molecular size using convex lens induced confinement is shown in Fig. 1. The apparatus is of a size that permits it to be integrated with conventional imaging instruments such as an inverted fluorescent microscope. Fig. 2 shows a photograph of an exemplary convex lens induced confinement apparatus 100 resting atop a microscope stage. In this particular embodiment, the apparatus is about 4" x 5" in area, although it may take on any size and can be even smaller.

[0068] One embodiment of the apparatus is described with reference to Figs. 1 and 3. The system employs an imaging microscope, e.g., a fluorescence microscope, including a high numerical aperture objective and an electron-multiplying CCD camera. The convex lens induced confinement apparatus 100 rests atop the microscope stage and includes a planar surface 110 having a sample measurement surface 115. The surface can include a glass coverslip (not shown) that can be disposed of or replaced after use. The surface is typically transparent to permit imaging of the sample from a light source below the microscope stage. The light source can be a laser, lamp or light emitting diode (LED). The convex lens induced confinement apparatus also includes a convex lens 120 that is positioned with its curved surface facing the planar surface 110. In some embodiments, the surface of the lens and/or the coverslip can be coated with a non-stick surface coating to reduce adhesion of molecules to the surfaces. When the lens 120 is lowered into contact with the planar surface, it contacts at a

single point **125** (shown on Fig. 3). The lens can include a handle **130**, typically attached to the back (planar) side of the lens, to aid in the positioning of the lens. The positioning handle is attached to an xyz translation stage **140** that provides for positioning capability in x-, y- and z- directions. Handle **130** is mounted to the translation stage at pivot **150** that moves the lens in the z-direction. Counterweight **160** can be used to balance the weight of the lens so that the lens rests lightly on the surface of the sample measurement surface and does not distort the surface.

[0069] Another version of the CLIC apparatus is illustrated in Figs. 9A and 9B, which is referred to as Flow Cell CLIC (FC-CLIC). As in the system shown in Fig. 1, the Flow Cell CLIC apparatus includes an imaging microscope **900** with similar features. The Flow Cell CLIC system also includes a convex lens **910** that can be raised and lowered into contact with the top surface of the flow cell **950**. As with CLIC, Flow Cell CLIC (FC-CLIC) confines molecules to a nanoscale gap. In CLIC, the gap is formed between the surfaces of a lens **120** and coverslip **125** (See, e.g., Figure 3a). In FC-CLIC, the sample is inserted between two initially planar sheets of transparent material **930, 940**, e.g., glass or fused silica, which make up the top and bottom surfaces of a flow cell, respectively. The top surface should be flexible, e.g. by using a thin glass sheet. The lens or other rounded object **910** presses down upon the top sheet **930** of the flow cell, causing it to bow downward until it makes contact with the bottom sheet **940** at a single point **945**. See, Fig. 9B. Molecules are imaged in the annular wedge-shaped gap surrounding the point of contact, as is described above. The convex surface can be raised or lowered onto the flow cell from a support **960**. Support **960** includes a lever **968** that can be pivotable, e.g. from hinge **965**, to lower and raise the convex surface **910**, which is attached to a lower surface of lever **968**. The hinge permits the lens surface to be moved out of the way for ease of access to the sample.

[0070] Adjustments to the lens position can be made on a fine-pitch screw **980** that is integrated into the aluminum lever and which conveys the motion to a small convex lens **910**, which pushes down on the top coverslip. This arrangement provides highly precise and reproducible formation of a nanoscale gap. By using a transparent lens to apply pressure to the top coverslip, optical access to both sides of the flow cell is maintained. This access is useful for illuminating the sample from both sides. The lens is optionally made of an elastomeric material such as poly(dimethyl siloxane), so that it does not scratch the flow cell at the point of contact.

[0071] The present design could be augmented by addition of a motorized positioner to apply pressure to the top coverslip. The positioner can have x, y, z-axis mobility for precise location of the convex surface. The positioner can be manually controlled or automated.

[0072] An exemplary flow cell is illustrated in Fig. 10. The flow cell is made up of two sheets of material 1000 and 1010, which serve as the top and bottom surfaces of the flow cell, respectively. The sheets are transparent, e.g., transparent to the light used to analyze the sample, and the top surface is flexible, e.g., capable of bending or being displaced from the resting position indicated in Fig. 9A and the displaced position indicated in Fig. 9B. The sheets can be made from glass or fused silica. In some instances the sheets can be made of plastics, so long as they have the required transparency. For fluorescence measurements, it is desirable for the sheet material to have low autofluorescence. In addition, the sheets should be relatively smooth. In order to accurately detect the confinement of molecules in the resulting gap, the sheets should be flat on the length scales of the molecules of interest. Ideally, the sheets have a RMS surface roughness < 1 nm, although for applications with larger molecules RMS surface roughness as large as 10 nm is acceptable. In some embodiments, the surface can be patterned, for example by lithography. Surface features can provide a further level of molecular confinement. For example, a surface can include an array of posts or dimples. The posts constrain the molecules between posts in addition to the constraint based upon the radius of curvature of the convex surface.

[0073] The flow cell includes side walls 1020 that define a spacing or gap 1030 between the upper and lower sheets 1000, 1010. The initial gap can range from a few microns, e.g., about 5 μm to about 500 μm . The amount of fluid needed for the space is therefore small and typically is about 10 μL . The side walls can be made of any suitable spacer or adhesive that provides the desired gap dimensions. By way of example, the side walls can double sided tape, polymer or plastic stripes, or glue or other adhesive, e.g., an epoxy adhesive. The flow cell is significantly larger than the test area, and has typical dimensions of 100 μm (vertical) by 7 – 12 mm (horizontal) (but can be smaller or larger than this). Because the test surface (typically on the order of 150 μm) is so much smaller than the overall flow cell and surface substantially centrally located, its distance from the side walls and the material selection for the side walls is not critical. The side walls are shown only on the long lengths of the flow cell; however, the flow cell can include front and rear walls of the flow cell as well.

[0074] Liquid is introduced into the flow cell at a suitable aperture. The apertures can include slots 1040, 1050 at the front and rear sides of the flow cell, as illustrated in Fig. 10. The slots can make up a full length of the flow cell or a portion thereof. In other embodiments, the apertures may be provided along the length of the side walls. In one or more embodiments, the side walls, front and rear walls are sealed, and apertures are provided in the upper and/or lower sheets of the flow cell.

[0075] In one exemplary embodiment, the flow cell channel is constructed using two parallel strips of double-sticky tape, sandwiched between two coverslips. Fluid flows through the gap between the pieces of tape, which has typical dimensions of 100 μm (vertical) by 7 – 12 mm (horizontal) by 25 mm (length). The width, height and length of the channel determine the volume of the cell, as well as the radius of curvature of the top coverslip at the point of contact. Furthermore, the lateral edges of the flow cell could be constructed of a more durable material than double-sided tape. An exemplary FC-CLIC is shown in Fig. 11.

[0076] In instances where a flowable adhesive is used, a consistent spacing of the desired gap dimension can be obtained by inserting a plastic sheet of the desired gap dimension between the upper and lower sheets of the flow cell. The plastic insert is smaller than the flow cell sheets so that the flow cell sheets extend beyond it on both lengths to define an open channel. The adhesive is applied in the channel and allowed to dry or at least to obtain sufficient mechanical strength to maintain the spacing between the two sheets, at which point the plastic insert can be removed.

[0077] The curvature of the flow cell during use is determined by various factors, such as the gap dimension and the width of the flow cell channel. For example, a vertical large gap will result in a steeper curvature (e.g. smaller radius of curvature), all other things equal. Similarly, increasing the width of the flow cell channel will reduce curvature (e.g., increase the radius of curvature). The point of contact can be varied to avoid locations in the flow cell where the glass surface has become contaminated, for example, by the sticking of test molecules to the glass surface. If the width of the flow cell channel varies along the length of the flow cell, e.g., by arranging that its walls are not parallel to one another but instead oriented at an angle, then by translating the lens along the length of the flow cell, one can vary the radius of curvature of the gap geometry. The actual geometry of the surface can be calculated, either prior to testing or in real time (*in situ*).

[0078] FC-CLIC offers several advantageous features. FC-CLIC is simple to set up and operate. The flow cell at the heart of the device is widely used in many biology labs, so the design will be familiar to prospective users.

[0079] The volume of the sample is small and can be 10-fold smaller sample volume than in CLIC (ca, 10 μ L for FC-CLIC vs. ca. 100 μ L for CLIC). The small sample volume is possible due to reduced evaporative losses because the flow cell is a mostly closed system. As the liquids evaporate and the solution concentrates, properties and characteristics of the molecules can change. In CLIC, the sample size is selected to be sufficiently large that evaporative losses are minimal. In FC-CLIC, there is no such constraint. In addition, the closed cell set up of the flow cell reduces exposure of the sample to ambient gases, particularly oxygen.

[0080] Simple chemical functionalization of top and bottom confining surfaces is readily available. It may be desirable to functionalize the sample holder surface to enhance or inhibit sample binding to the sample holder or the convex surface. In other embodiments, it may be desirable to monitor the interaction between the molecules of interest in solution and functionalized molecules on the sample holder surface. While it is possible to functionalize either the lower coverslip surface or the convex surface used in CLIC systems, the functionalization of the glass or fused silica used as coverslips is well known and easy.

[0081] The samples can be easily exchanged after measurement by lateral flow of fluid through the flow cell. This ability permits rapid and simple testing for serial measurements. Also, the flow cell configuration is compatible with lithographic processing on the confining surfaces. The flat surfaces of the flow cell are easier to pattern than the permanently curved surface of, for example, a convex lens.

[0082] The use of the flow cell in conjunction with a movable lens provides a simple procedure for moving the point of contact between top and bottom confining surfaces. As noted above, the geometry of the confining surface can be readily controlled and easily varied by moving the contact point of the lens with the flow cell. Contacting the flow cell in two different points results in two different surfaces. Due to the scale of the flow cell relative to the field of view in the imaging device, movements result in small well-defined changes. The geometry of the confining surface can be measured in situ or calculated prior to testing using

conventional interferometry measurements or measurements of the fluorescence intensity profile of a homogeneous solution of a small fluorescent molecule.

[0083] The use of a flow cell to contain the sample fluid instead of a convex surface such as a lens opens up a wider and more versatile list of materials to use for the confining surfaces. Lenses are made up of a limited number of materials, but cover slips are made of a wide variety of materials, such as mica, plastics and sapphire, that are not commonly used for lenses. The wide range of material compositions for the confining surfaces in a FC-CLIC system provides greater flexibility and versatility in the testing environment. In addition, the materials used to prepare the flow cell are inexpensive. A sample chamber can be composed entirely of disposable parts, eliminating the need for meticulous cleaning between experiments.

[0084] In the operation of the CLIC or FC-CLIC device, a sample to be measured is applied to the sample measurement surface, before or after the convex lens is moved into contact with the surface. The lens may be lowered to the surface before or after the sample is applied. In some embodiments, the lens is moved into contact with the surface before the sample liquid is applied and the sample is drawn into the gap defined by the test surface and the lens by wicking or capillary action. In other embodiments, the lens is raised, the sample liquid is applied and the lens is gently lowered onto the cover slip. As noted above, the lens-cover slip distance (“gap”) varies smoothly from zero at the point of contact, to hundreds of microns at radii far from the point of contact. The molecules can only occupy space where the gap is equal to or greater than their diameter, that is, the molecule is excluded from those areas under the lens where the gap is less than the molecular size. Measurement of the distance of the onset of fluorescence from the center point, coupled with information regarding the curvature of the lens surface provides a measurement of the molecular size.

[0085] The CLIC and FC-CLIC systems can also be used to characterize the molecular size distributions of mixtures of molecules of a few sizes by analyzing the first- and second-derivatives of the total fluorescence intensity with respect to radius from the point of contact. These profiles can exhibit a ‘kink’, or distinguishable feature, at the radius of exclusion corresponding to each constituent molecule in the mixture. In addition, by employing particle tracking software, one may determine the distribution of diffusion coefficients of molecules as a function of gap height as a diagnostic of molecular mixtures. For example, in characterizing a mixture of large and small molecules, one would detect a higher fraction of molecules with

low diffusion coefficients further from the contact point than in the case of a homogeneous sample of small molecules.

[0086] In some embodiments, the analyte is fluorescent or fluorescently labeled. The molecules can be inherently fluorescent, or they can be modified with a fluorescent tag. By way of example, the analyte can be covalently labeled with a fluorescent dye such as Alexa Fluor dyes. For protein analytes, the protein can be fused with a green fluorescent protein marker (*Nat Methods* 2 (12): 905–9). In most instances, the size of the label is not expected to interfere with the measurement. In other embodiments, a protein-specific fluorescent antibody can be used. In this instance, the molecular size of a particular protein could be determined without the need to purify the sample. In other embodiments, the samples can be inherently fluorescent, as for example proteins are under short wave ultraviolet irradiation. In such instances, additional measures can be taken such as using ‘fluorescent-free’ materials in the construction of the device to prevent high background fluorescence.

[0087] The CLIC and FC-CLIC systems can be used to measure the distribution or sizes of molecules of about 10 nm to about 1000 nm, such as DNA ranging from ~2,000 – 48,000 bp, 200 nm lipid vesicles, and polystyrene spheres with diameters ranging from 20 – 200 nm. The method can also be used with smaller particles, such as individual protein molecules, fluorescent micelles, and short DNA oligonucleotides. The CLIC and FC-CLIC systems can operate over a range of analyte concentrations, e.g. 10 pM-10 μ M. Low liquid volumes also may be employed (1-100 μ L).

[0088] While measurements of molecular size are likely to have the greatest impact as a medical diagnostic, the CLIC and FC-CLIC system also enable several new types of single-molecule measurements that may interest researchers. These measurements include a) fluorescence measurements on single immobilized molecules in the presence of a high background concentration of freely diffusing fluorescent molecules; and b) long-time observation of single freely diffusing fluorescent molecules. In both cases, the thin confinement provided by the CLIC and FC-CLIC systems create the optical conditions for higher quality single-molecule imaging than was previously possible.

[0089] The CLIC system has been used to characterize the size of a range of fluorescently labeled molecules. Fig. 4 delineates the fluorescence signal, measured as a function of gap height, for ensembles of linear DNA molecules, and free dye (Alexa 647). To a first

approximation, the molecules can be treated as hard spheres, valid for $h \gg d_{hs}$. The molecular diameter, d_{hs} , can be determined from the x-intercept of the linear fit to the fluorescence profile in this region. For linear DNA samples of ϕ X174 and pUC 19, $r_{hs} = 0.19 \pm 0.02 \mu\text{m}$ and $0.15 \pm 0.03 \mu\text{m}$ respectively. These estimates were in good agreement with literature-inferred radii of gyration, $r_{gyr} = 0.20 \mu\text{m}$ and $0.13 \mu\text{m}$ respectively.

[0090] For sufficiently large molecules and negligible surface interactions, r_{hs} provides an accurate measure of molecular size. In situations where surface interactions dominate, such as when the salt concentration is sufficiently low that the Debye length is non-negligible, molecules can be repelled from or attracted to the surface, altering the observed R_{excl} , *the radius of exclusion for the molecules of interest*. Such contributions to R_{excl} due to electrostatic interactions can be calibrated *a priori* and taken into account in calculating r_{hs} . Alternatively, by coating the surface with a neutral monolayer such as polyethylene glycol (PEG), attractive interactions may be suppressed.

[0091] In one embodiment, the device and method can be used to measure the distribution of sizes and shapes of amyloid fibrils. The aggregation of amyloids and their structural traits are associated with the development of neurodegenerative diseases. Since this device and method can be used to characterize the change in size and shape of samples of amyloid fibrils as the diseases progress, it can serve as an important medical diagnostic tool.

[0092] A standard working criteria for single-molecule detection is for the detection volume to be occupied by less than one fluorophore on average. Therefore, decreasing the detection volume enables single-molecule detection at higher background fluorophore concentration. Near the lens contact point, the detection volume is smaller in depth than that of either confocal or TIRF imaging and is of comparable extent within the imaging plane. Single immobilized molecules can therefore be detected against a higher background concentration of fluorophores by CLIC or FC-CLIC than by TIRF or confocal microscopy. Details and comparison of CLIC, FC-CLIC and conventional imaging systems is found in Table 1. The improved rejection of background was demonstrated by comparing images taken with CLIC to images taken with TIRF. Singly labeled DNA oligonucleotides were used as a model system. The sample was immobilized on a coverslip and imaged in the presence of a variable concentration of free dye.

[0093] Through-the-objective TIRF illuminates a thin sheet of solution adjacent to the coverslip-solution interface. The detection volume is approximately $V_{\text{det}} = \pi r_d^2 h^{\text{TIRF}}$, where $r_d \sim \lambda/2 \text{ NA}$ is the radius of a diffraction-limited spot, and $h^{\text{TIRF}} \sim \lambda/2\pi$ is the evanescent decay length. In a typical setup with illumination at $\lambda = 633 \text{ nm}$ and an objective with numerical aperture $\text{NA} = 1.45$, $r_d = 218 \text{ nm}$ and $h^{\text{TIRF}} = 101 \text{ nm}$. Single-molecule detection via TIRF is possible only when the fluorescent background concentration $C_{\text{max}}^{\text{TIRF}} < 180 \text{ nM}$. The single-

molecule concentration limit for CLIC is $C_{\text{max}}^{\text{CLIC}} = \frac{h^{\text{TIRF}}}{h^{\text{CLIC}}} C_{\text{max}}^{\text{TIRF}}$.

[0094] The improved rejection of background under CLIC imaging is shown in Figure 5. Single immobilized fluorophores were imaged against a background of up to $4 \mu\text{M}$ of free dye, 20-fold higher than $C_{\text{max}}^{\text{TIRF}}$. Figure 5 shows the signal-to-background ratio as a function of confinement, for CLIC imaging of surface-immobilized fluorescent polystyrene beads immersed in 50 nM Alexa 647. Probe illumination corresponds to $\lambda=633 \text{ nm}$, and $P=120 \mu\text{W}$. Under TIRF illumination conditions the background becomes independent of h^{CLIC} when $h^{\text{CLIC}} > h^{\text{TIRF}}$. Fig. 6 shows a CLIC image of surface-tethered DNA oligonucleotides in the presence of $0.2 \mu\text{M}$ Alexa 647 at $P=6 \text{ mW}$. A nonlinear contrast scale was applied to permit visualization in the same image of the single molecules at small r and the background fluorescence at large r . Fig. 7 shows a photobleaching timetrace of a single molecule (circled in Fig. 6), and a timetrace of the fluorescence from a point where there was no immobilized molecule. Fig. 8 are CLIC images of free dye (Alexa 647) at concentrations of $0.2 \mu\text{M}$, $1 \mu\text{M}$, and $C=2 \mu\text{M}$, with equal-fluorescence contours indicated. At $2 \mu\text{M}$ Alexa 647, single oligos molecules may be detected within a disk of radius $r = 21 \mu\text{m}$, corresponding to $h^{\text{CLIC}} = 5 \text{ nm}$, in good agreement with the expected detection limit.

[0095] Comparison of the imaging characteristics of the CLIC method as compared to conventional methods is shown in the table.

[0096] Table 1

Imaging modality	Dimensions of imaging volume L×W×H (μm)	Max concentration of single molecules	Observation time (<i>D</i> = 100 μm ² /s)	# of molecules observed simultaneously
TIRF	100 × 100 × 0.1	180 nM	500 μs (vertical)	hundreds
Confocal	$\pi \times 0.3^2 \times 1$	50 nM	200 μs (in-plane)	1
Zero-mode waveguides	.04 × .04 × .02	50 μM	2 μs (vertical)	Thousands; 1 per waveguide
ABEL trap	3 × 3 × 0.8	200 pM	2 s (photobleaching)	1
Convex Lens-Induced Confinement (CLIC)	100 × 100 × 0.005	4 μM	25 s (in-plane)	hundreds

[0097] The foregoing illustrates one specific embodiment of this invention. Other modifications and variations of the invention will be readily apparent to those of skill in the art in view of the teaching presented herein. The foregoing is intended as an illustration, but not a limitation, upon the practice of the invention. It is the following claims, including all equivalents, which define the scope of the invention.

[0098] What is claimed is:

Claims

1. A method for detecting size of a molecule, comprising:
 - applying a liquid sample containing molecules to be measured to a sample measurement surface;
 - contacting the sample measurement surface with a curved surface positioned tangent to the sample measurement surface at a point or line of contact, said curved surface having a surface that varies in a predetermined and understood manner from the point or line of contact to a displaced position relative to the point or line of contact;
 - subjecting the sample to imaging to identify a region where sample is present; and
 - determining the location of the sample presence from the point of contact outward, wherein the location of the sample is an indication of molecular size.
2. The method of claim 1, wherein the imaging detects fluorescence.
3. The method of claim 1, wherein the imaging detects light absorbance.
4. The method of claim 1, wherein the curved surface comprises a convex lens, and for example, the convex surface is selected from the group consisting of convex, biconvex, plano-convex, and concave convex lenses.
5. The method of claim 1, wherein the curved surface comprises a cylindrical lens.
6. The method of claim 1, wherein the curved surface is obtained by deflecting a flexible sheet disposed above the sample measurement surface into contact with the sample measurement surface.
7. The method of claim 2, further comprising:
 - correlating the location of the fluorescence with a distance of the lens surface to the planar surface, said distance representing a molecular dimension of the molecules.
8. The method of claim 1, wherein molecule size is determined.
9. The method of claim 1, wherein molecule size distribution is determined.

10. The method of claim 9, wherein fluorescent imaging provides a gradual transition from a dark region to a bright fluorescence region.
11. The method of claim 1, wherein molecular aspect ratio is determined.
12. The method of claim 1, wherein the molecular size ranges from about 2 nm to about 1000 nm.
13. The method of claim 1, wherein the sample measurement surface comprises a flow cell having an upper and a lower surface for receiving a sample to measured, and the convex surface is provided by deflecting the upper surface of the flow cell downward to the lower surface of the flow cell to create the contact point.
14. The method of claim 1, further comprising:
 - coating the convex surface and/or the sample measurement surface with a non-stick coating.
15. The method of any preceding claim, wherein the molecule is a biomolecule, for example, proteins, micelles or DNA, or a polymer molecule, for example, polymer beads.
16. The method of any preceding claim, wherein the sample measurement surface and/or the curved surface comprises surface features, and for example, the surface features are selected from the group of dimples and posts.
17. A system for detecting size of a molecule, comprising:
 - a sample measurement zone having a convex surface positioned tangent to a planar surface, coupled with an inverted fluorescent microscope positioned to detect the presence of a molecule of interest in the sample measurement zone.
18. A system for detecting size of a molecule, comprising:
 - a sample measurement zone having a convex surface positioned tangent to a planar surface, coupled with an imaging device capable of detecting the presence of a molecule of interest present in the sample measurement zone.

19. The system of claim 18, wherein the imaging device is capable of detecting light absorbance or fluorescence.
20. The system of claim 17, 18 or 19, wherein the molecule of interest is a biomolecule, for example, proteins, micelles or DNA, or a polymer molecule, for example, polymer beads.
21. The system of claim 17 or 18, further comprising a translation stage for positioning the convex surface in the x-, y-, and z-directions.
22. The system of claim 17 or 18, wherein the convex surface comprises a convex lens, and for example, the convex surface is selected from the group consisting of convex, biconvex, plano-convex, and concave convex lenses.
23. The system of claim 21, wherein the lens is coupled with a counterweight to reduce the resting force of the lens on the planar surface.
24. The system of claim 18, wherein the convex surface is coated with an anti-stick coating.
25. The system of claim 17 or 18, wherein the sample measurement zone comprises a flow cell for receiving a sample to be measured, said flow cell comprising upper and lower sheets spaced apart from one another a distance defined by side walls.
26. The system of claim 25, further comprising a deflector, positioned above the flow cell, for reversibly deflecting the upper surface of the flow cell into contact with the lower surface of the flow cell to form the convex surface of the sample measurement zone.
27. The system of claim 25, further comprising a translation stage for positioning the convex surface in and out of deformation contact with the flow cell.
28. The system of claim 25, wherein the width of the flow cell varies along its length.
29. The system of any of claims 17 to 29, further comprising imaging software or particle tracking software.
30. A method for detecting size of a molecule, comprising:

applying a liquid sample containing molecules to be measured to a sample measurement zone, the sample measurement zone having a transparent material positioned tangent to a

planar surface, said material having a surface that varies in a predetermined manner from the point of contact to a radially displaced position relative to the point of contact;

subjecting the sample to fluorescent imaging to identify a region where the fluorescence is observed; and

determining the location of the fluorescence relative to the point of contact, wherein the location of the fluorescence is an indication of molecular size.

31. The method of claim 30, where the transparent material is wedge-shaped.

32. The method of claim 30, wherein the transparent material is curvilinear.

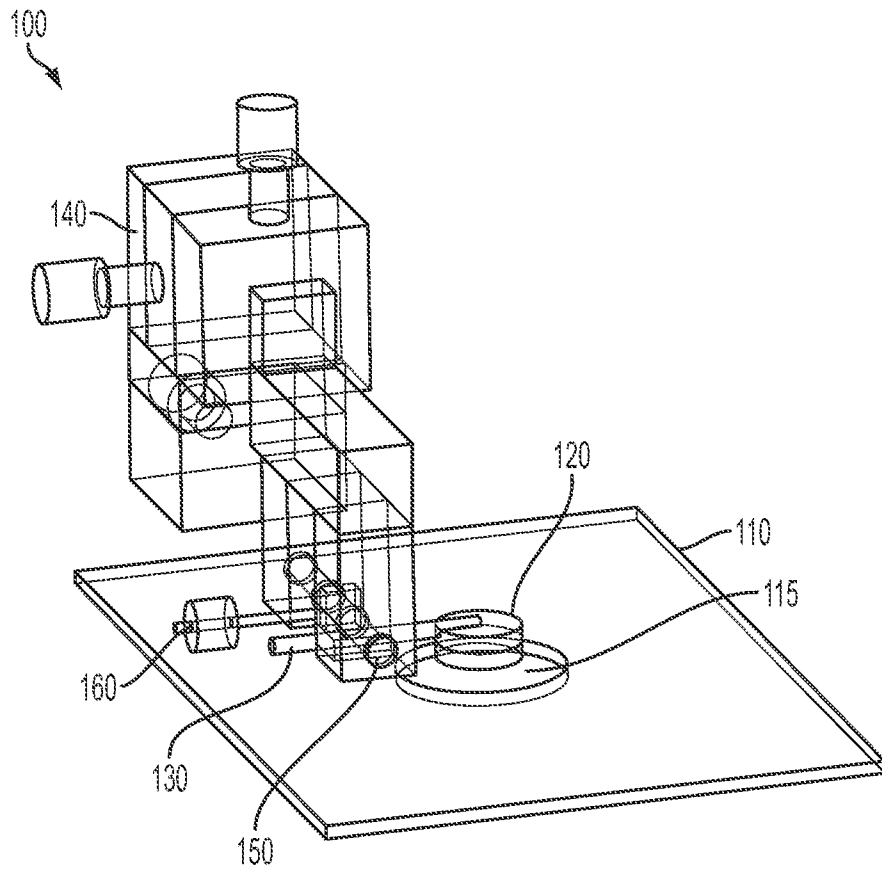

FIG. 1

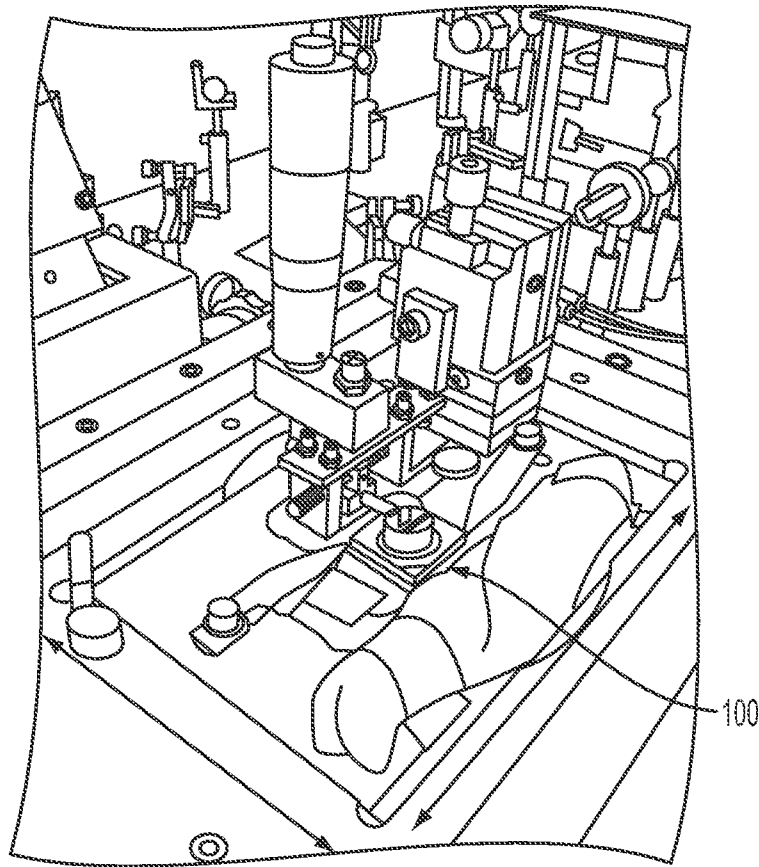

FIG. 2

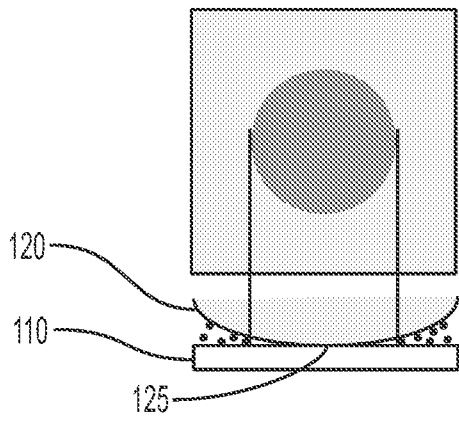

FIG. 3A

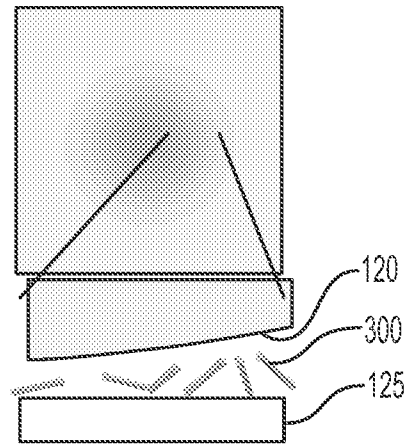

FIG. 3B

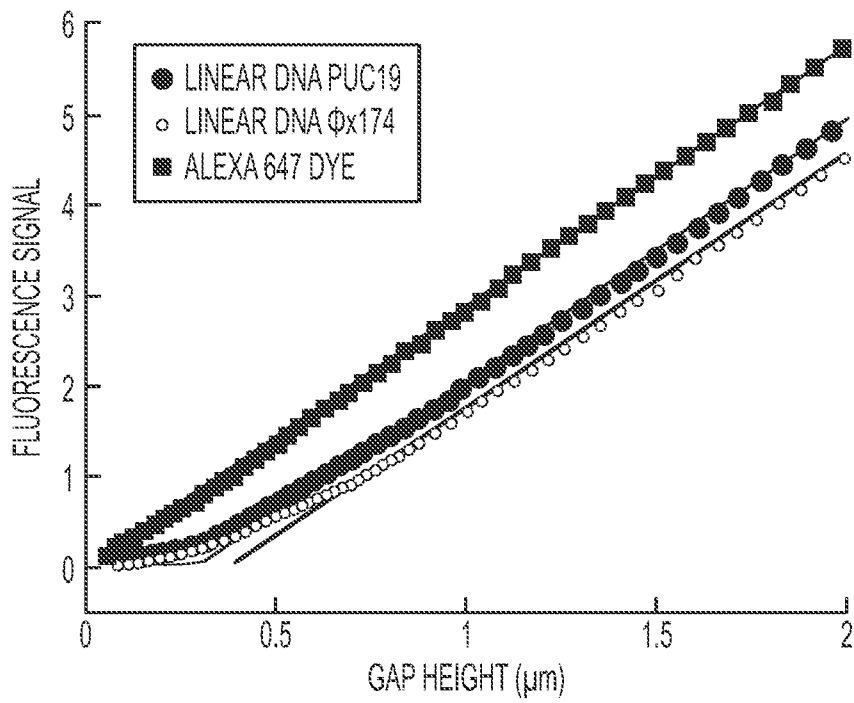

FIG. 4

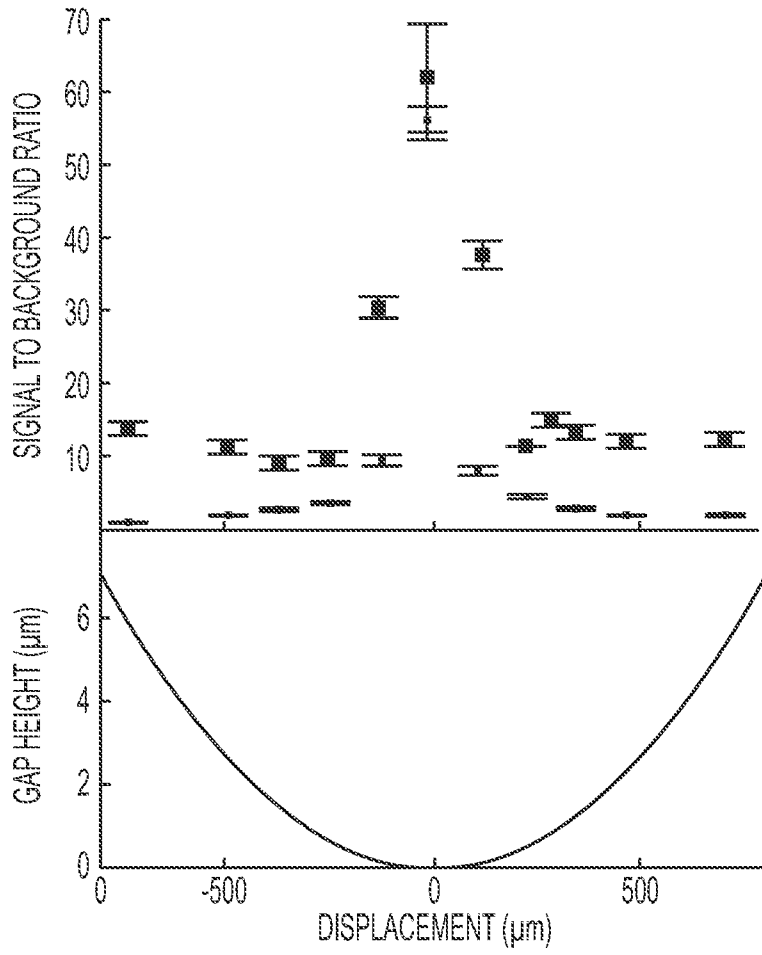

FIG. 5

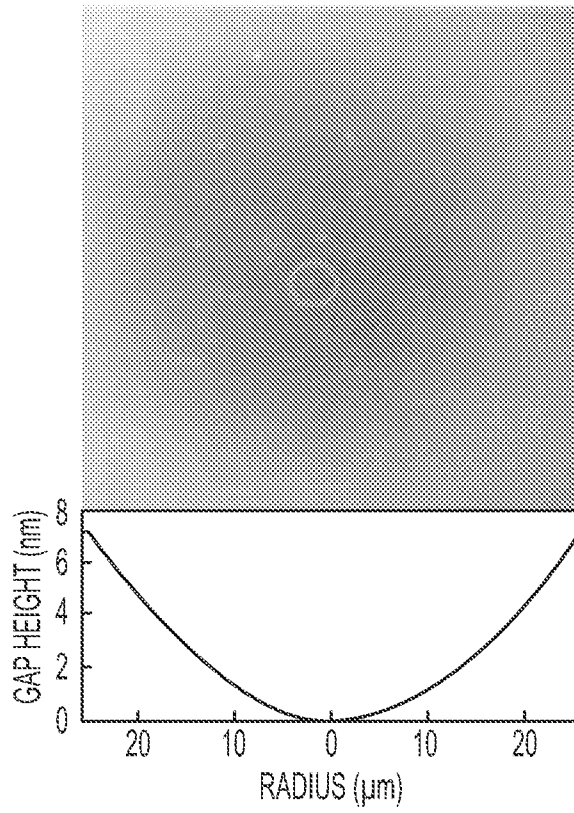

FIG. 6

7/11

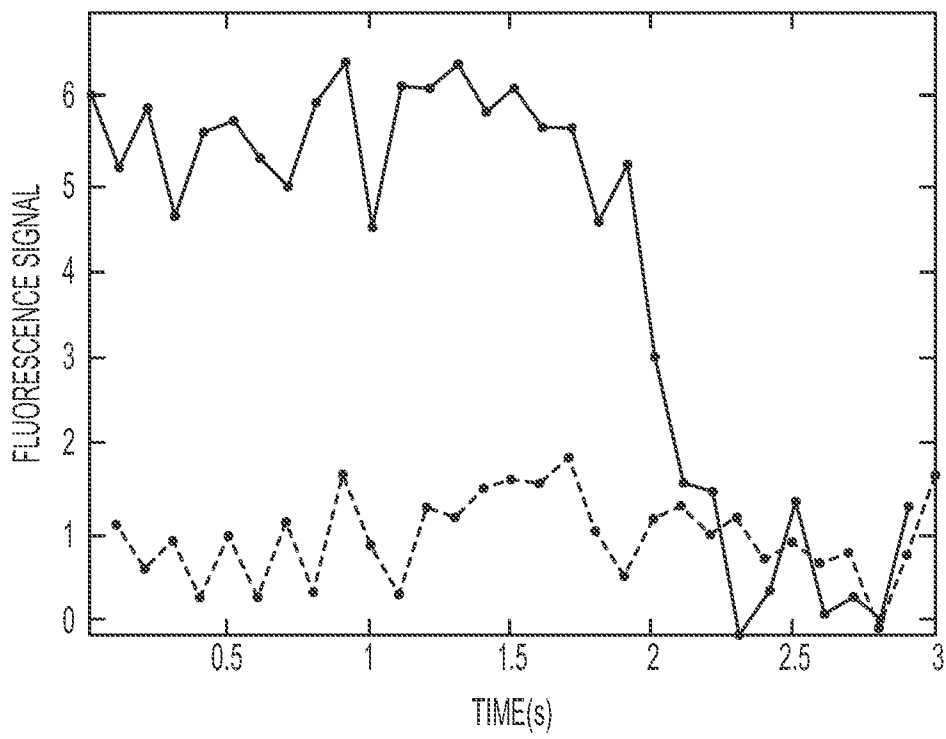

FIG. 7

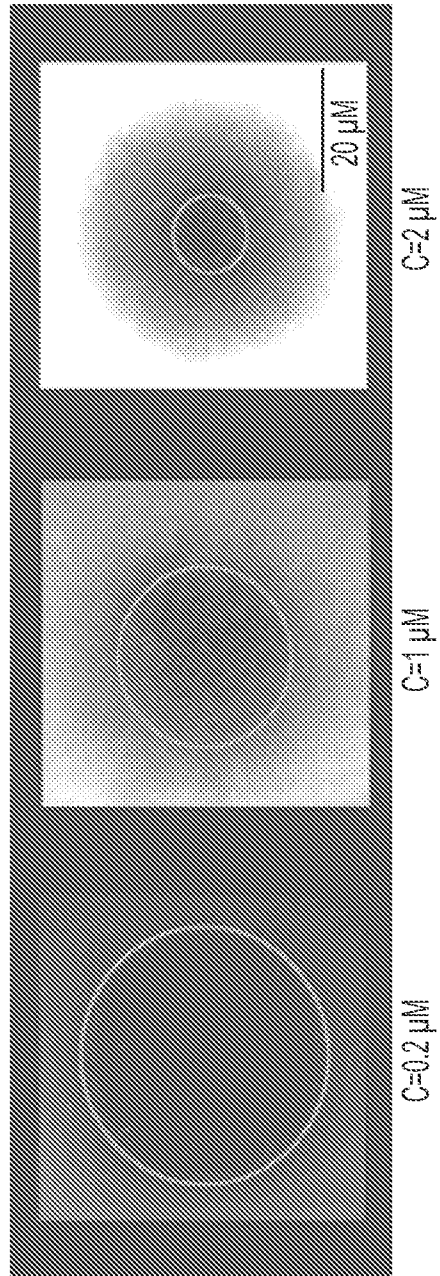

FIG. 8

9/11

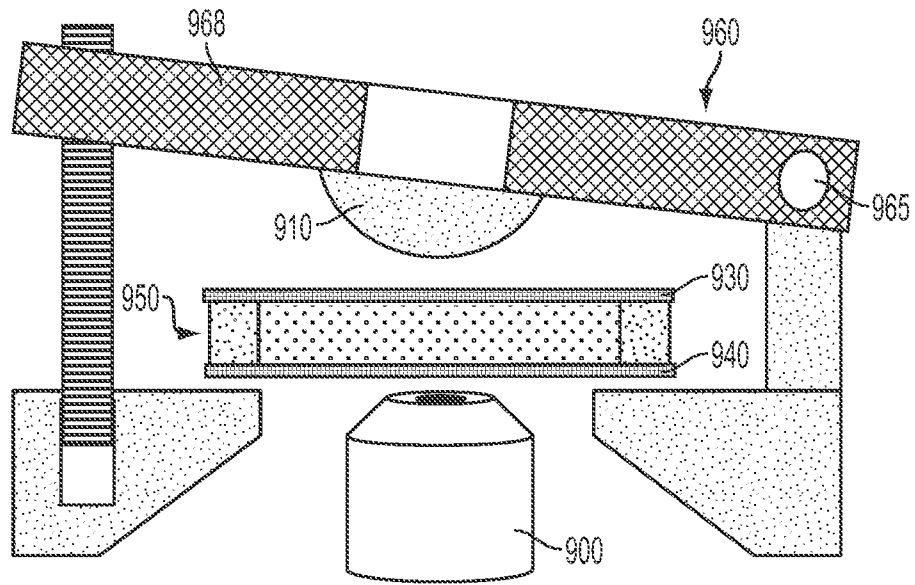

FIG. 9A

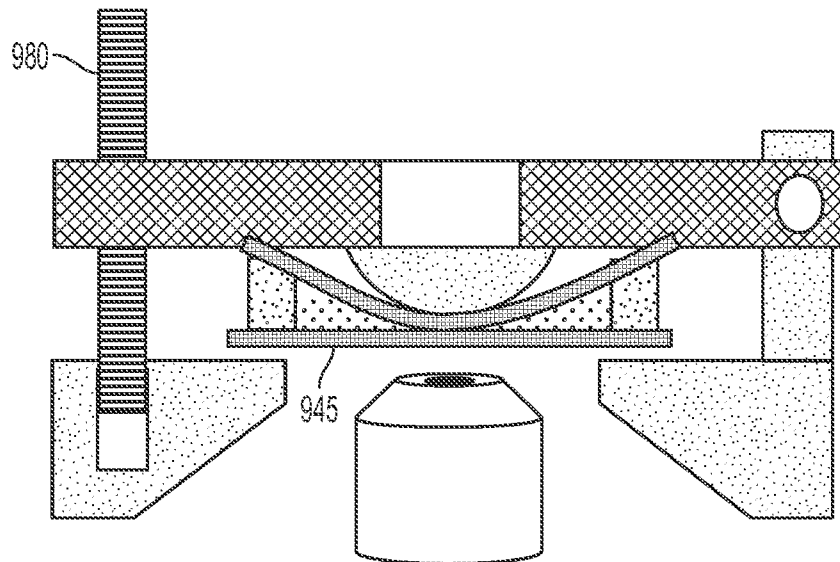

FIG. 9B

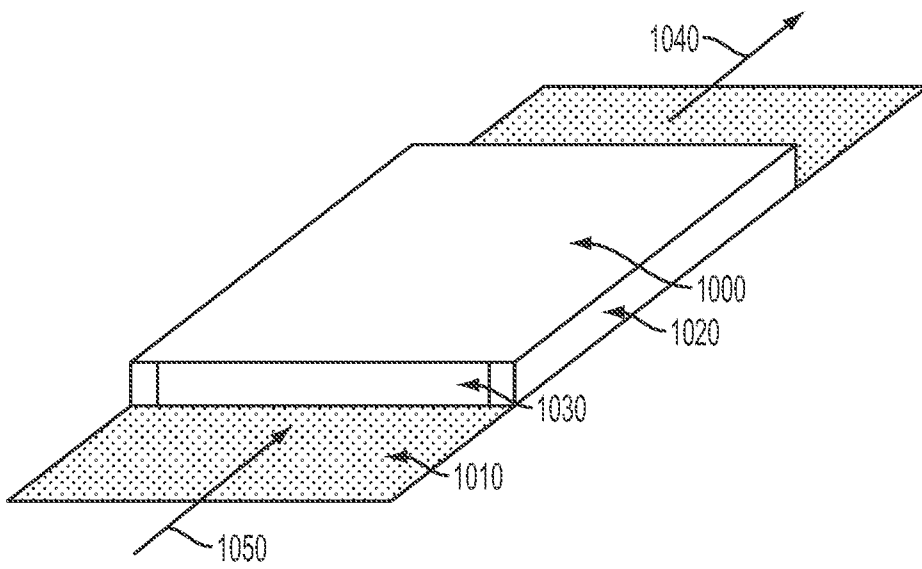

FIG. 10

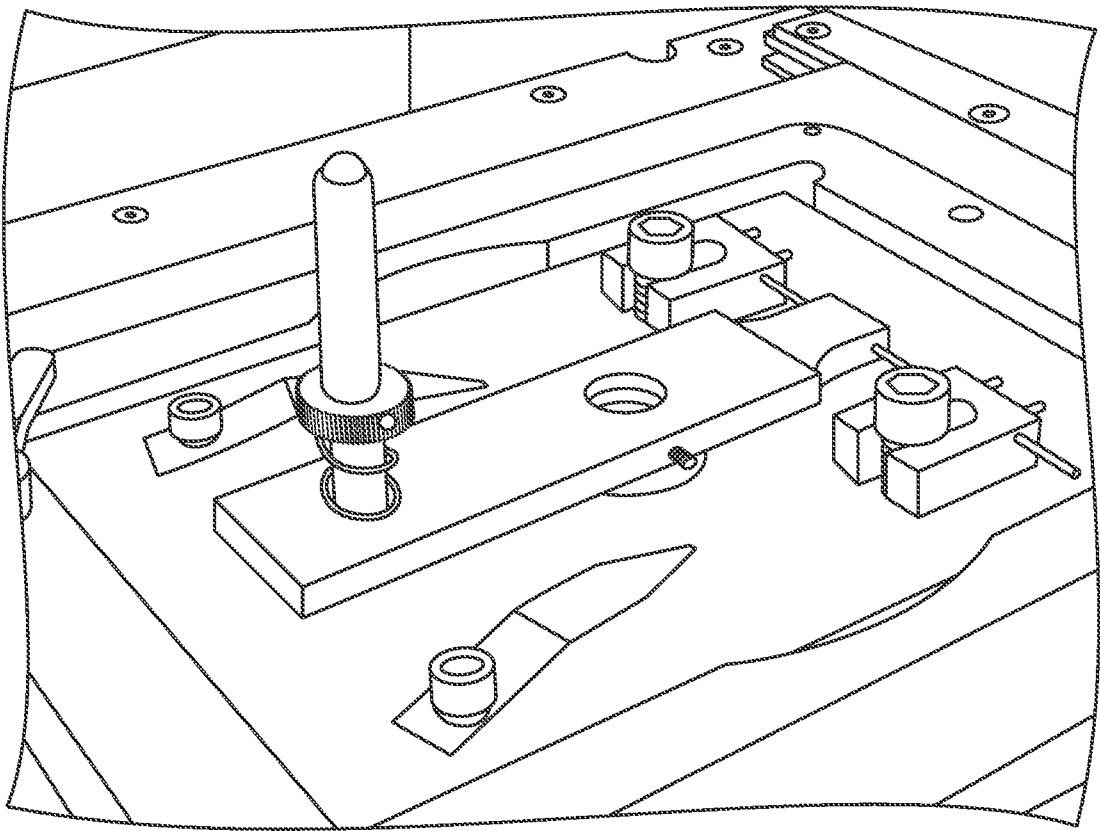

FIG. 11

INTERNATIONAL SEARCH REPORT

International application No
PCT/US2011/021403

A. CLASSIFICATION OF SUBJECT MATTER
INV. G01N15/14 G02B21/34
ADD.
According to International Patent Classification (IPC) or to both national classification and IPC

B. FIELDS SEARCHED

Minimum documentation searched (classification system followed by classification symbols)
G01N G02B

Documentation searched other than minimum documentation to the extent that such documents are included in the fields searched

Electronic data base consulted during the international search (name of data base and, where practical, search terms used)
EPO-Internal, WPI Data

C. DOCUMENTS CONSIDERED TO BE RELEVANT

Category*	Citation of document, with indication, where appropriate, of the relevant passages	Relevant to claim No.
X	WO 99/44593 A1 (WARDLAW STEPHEN C [US]) 10 September 1999 (1999-09-10)	1-5,7-32
Y	abstract figures page 5, line 13 - page 9, line 7 page 11, line 2 - page 21, line 9	6
Y	EP 0 961 110 A2 (BECTON DICKINSON CO [US]) 1 December 1999 (1999-12-01) abstract figures paragraph [0013] - paragraph [0035]	6
A	EP 1 219 963 A1 (BECTON DICKINSON CO [US]) 3 July 2002 (2002-07-03) abstract figures paragraph [0010] - paragraph [0031]	1-32
	----- -/--	

Further documents are listed in the continuation of Box C.

See patent family annex.

* Special categories of cited documents :

"A" document defining the general state of the art which is not considered to be of particular relevance

"E" earlier document but published on or after the international filing date

"L" document which may throw doubts on priority claim(s) or which is cited to establish the publication date of another citation or other special reason (as specified)

"O" document referring to an oral disclosure, use, exhibition or other means

"P" document published prior to the international filing date but later than the priority date claimed

"T" later document published after the international filing date or priority date and not in conflict with the application but cited to understand the principle or theory underlying the invention

"X" document of particular relevance; the claimed invention cannot be considered novel or cannot be considered to involve an inventive step when the document is taken alone

"Y" document of particular relevance; the claimed invention cannot be considered to involve an inventive step when the document is combined with one or more other such documents, such combination being obvious to a person skilled in the art.

"&" document member of the same patent family

Date of the actual completion of the international search 16 May 2011	Date of mailing of the international search report 25/05/2011
--	--

Name and mailing address of the ISA/ European Patent Office, P.B. 5818 Patentlaan 2 NL - 2280 HV Rijswijk Tel. (+31-70) 340-2040, Fax: (+31-70) 340-3016	Authorized officer Ruchaud, Nicolas
--	--

INTERNATIONAL SEARCH REPORT

International application No
PCT/US2011/021403

C(Continuation). DOCUMENTS CONSIDERED TO BE RELEVANT		
Category*	Citation of document, with indication, where appropriate, of the relevant passages	Relevant to claim No.
A	EP 0 479 231 A1 (CANON KK [JP]) 8 April 1992 (1992-04-08) abstract figures -----	1-32

INTERNATIONAL SEARCH REPORT

Information on patent family members

International application No PCT/US2011/021403

Patent document cited in search report	Publication date	Patent family member(s)	Publication date
WO 9944593	A1	10-09-1999	AT 283688 T 15-12-2004
			AU 744435 B2 21-02-2002
			AU 2687999 A 20-09-1999
			CA 2323087 A1 10-09-1999
			CN 1292685 A 25-04-2001
			DE 69922355 D1 05-01-2005
			DE 69922355 T2 24-11-2005
			EP 1063974 A1 03-01-2001
			JP 4290876 B2 08-07-2009
			JP 2002516982 T 11-06-2002
			NO 20004453 A 06-11-2000
			US 6235536 B1 22-05-2001
EP 0961110	A2	01-12-1999	JP 11352411 A 24-12-1999
			US 6358475 B1 19-03-2002
EP 1219963	A1	03-07-2002	AT 290689 T 15-03-2005
			DE 60109261 D1 14-04-2005
			DE 60109261 T2 04-05-2006
			JP 2002318189 A 31-10-2002
			MX PA01013108 A 08-06-2005
			US 2002118353 A1 29-08-2002
EP 0479231	A1	08-04-1992	DE 69118295 D1 02-05-1996
			DE 69118295 T2 19-09-1996
			US 5427959 A 27-06-1995