

(12) UK Patent Application (19) GB (11) 2 325 640 (13) A

(43) Date of A Publication 02.12.1998

(21) Application No 9811402.8

(22) Date of Filing 27.05.1998

(30) Priority Data

(31) 970380 (32) 27.05.1997 (33) IE  
(31) S970381 (32) 27.05.1997  
(31) S970382 (32) 27.05.1997

(71) Applicant(s)

**Kingspan Research and Developments Limited  
(Incorporated in Ireland)  
Dublin Road, Kingscourt, County Cavan, Ireland**

(72) Inventor(s)

**Eoin T McCarthy  
Patrick McDonald  
Thomas McGuinness  
Paul Martin**

(74) Agent and/or Address for Service

**Marks & Clerk  
57-60 Lincoln's Inn Fields, LONDON, WC2A 3LS,  
United Kingdom**

(51) INT CL<sup>6</sup>

**B29C 44/32 , B32B 5/20 , E04C 2/292**

(52) UK CL (Edition P )

**B5N N0304 N0306 N0328 N0518 N0520 N1508 N1518  
N1520 N195 N196 N199 N20Y N207 N209 N21Y N223  
N225 N247 N2728 N2740 N3106 N3108 N3118 N389  
N393 N394 N46X N491 N492 N515 N516 N519 N534  
N535 N536 N556 N558 N559 N589 N603 N63Y N630  
N639 N648 N649 N650 N657 N658 N66Y N661 N667  
N668 N677 N68Y N681 N682 N685 N686 N688 N692  
N693 N694 N695 N696 N697 N70Y N718 N72Y N727  
N735 N74X N76X  
U1S S1405 S1700 S1707 S1708**

(56) Documents Cited

**GB 2309412 A GB 2257086 A GB 2227712 A**

(58) Field of Search

**UK CL (Edition P ) B5N  
INT CL<sup>6</sup> B29C 44/32 , B32B 5/20 31/00 , E04C 2/292  
ONLINE:WPI**

(54) Abstract Title

**Manufacturing insulating panels**

(57) A panel 1 comprises a profiled external skin 2, an internal backing tray 3 and an insulating core 4 which fills the space between the skin 2 and tray 3. A strip of reflective tape 11 is applied to the external skin 2. External skins 2 are overlapped, liquid foam reactants applied and a backing tray 3 is applied over the skins 2. The liquid foam reactants expand, on heating in an oven 50, 51 to form a foam insulating core. The backing tray 3 and foam core 4 are cut in a single cutting stage which is triggered by the reflective tape. The panels 1 are separated at the joint and then stacked for packing.

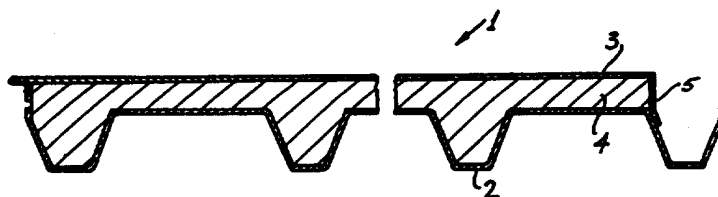
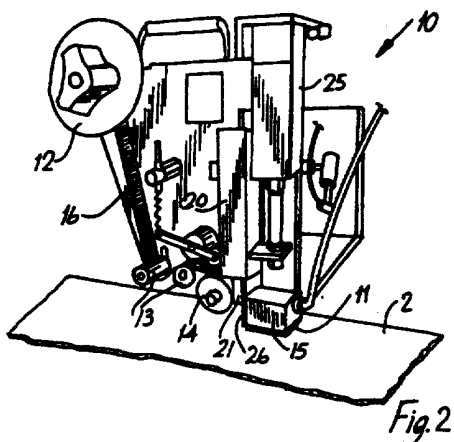

Fig. 19

GB 2 325 640 A

1/14

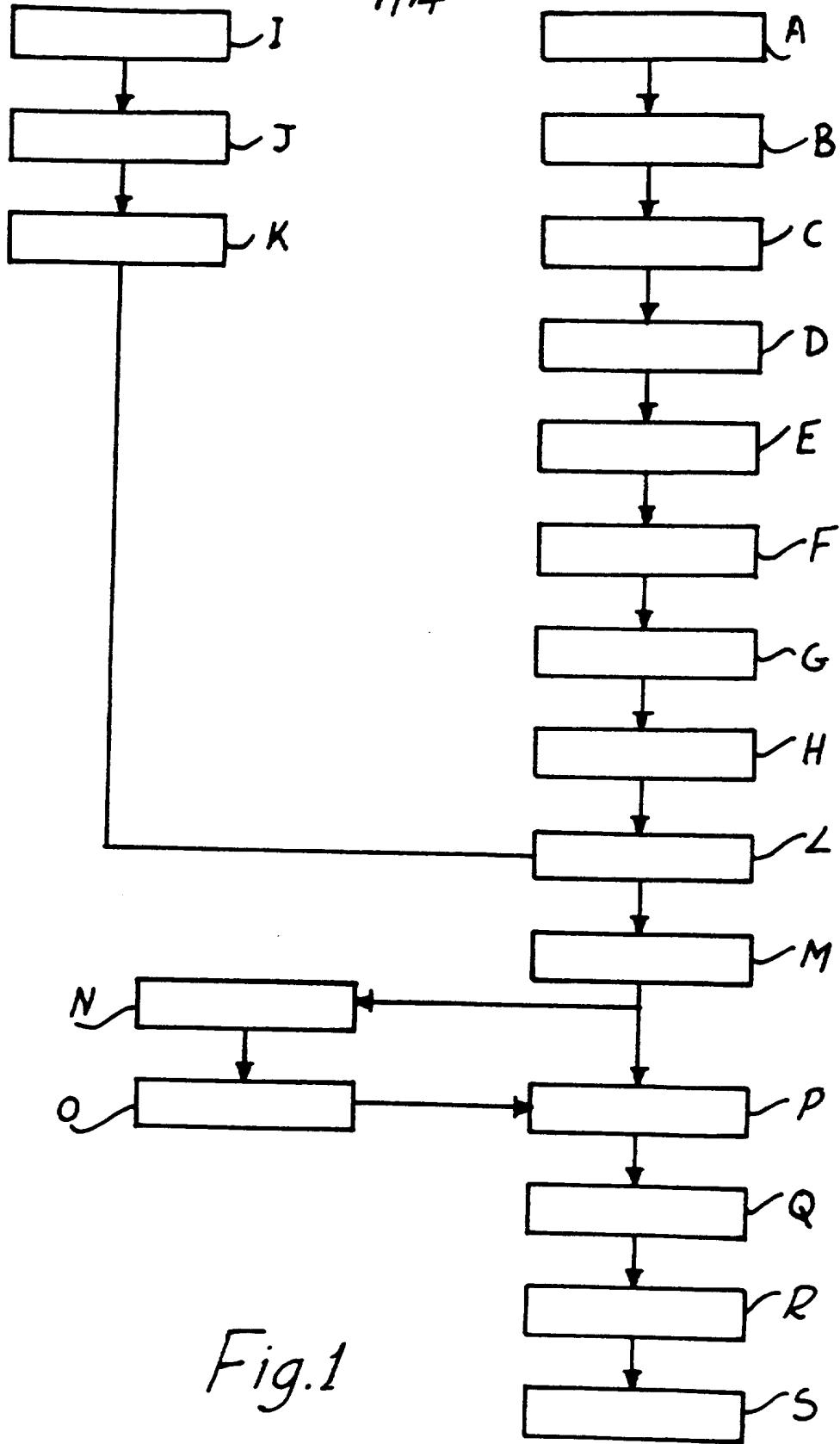

Fig.1

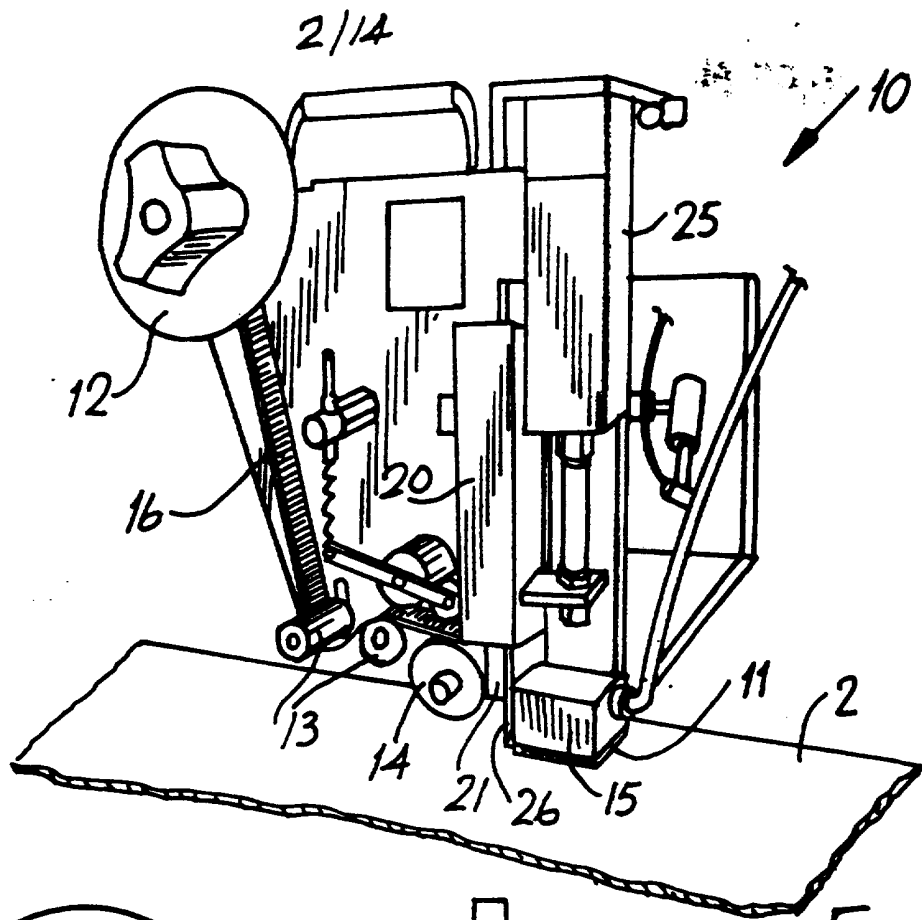

Fig. 2

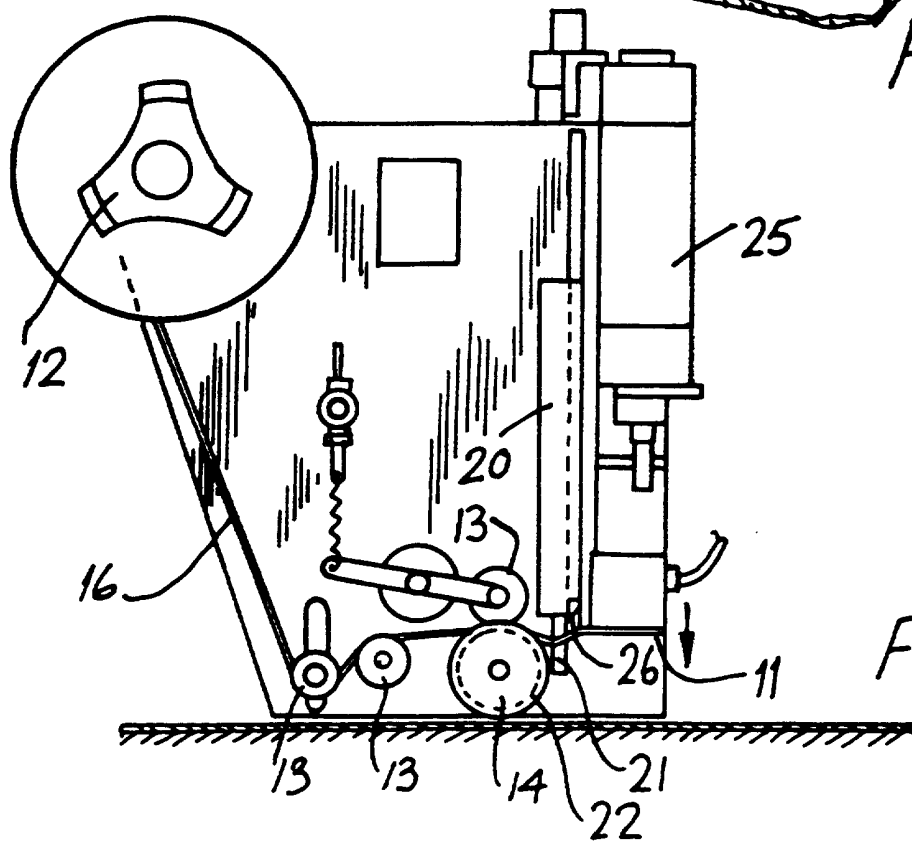

Fig. 3

3/14

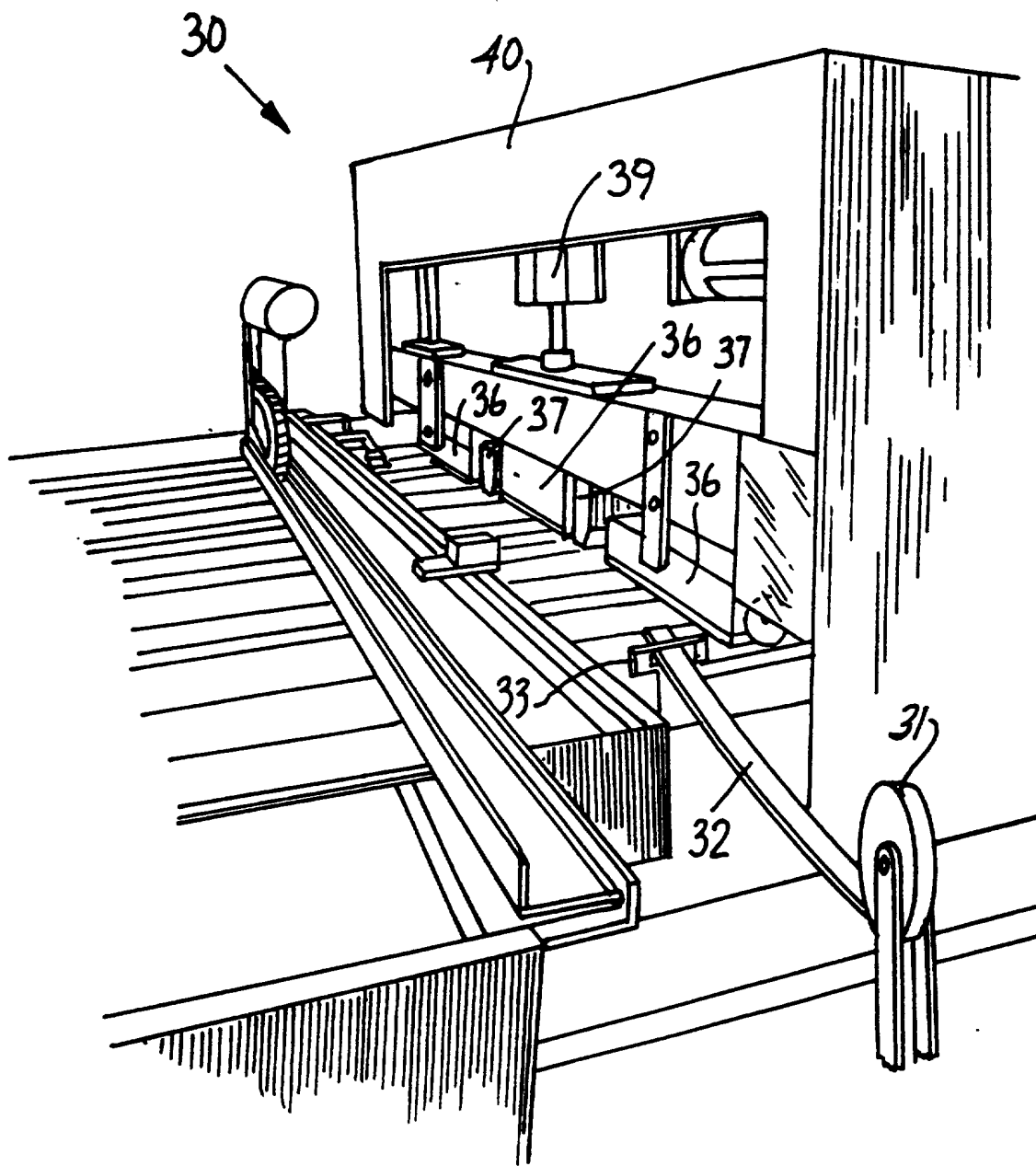
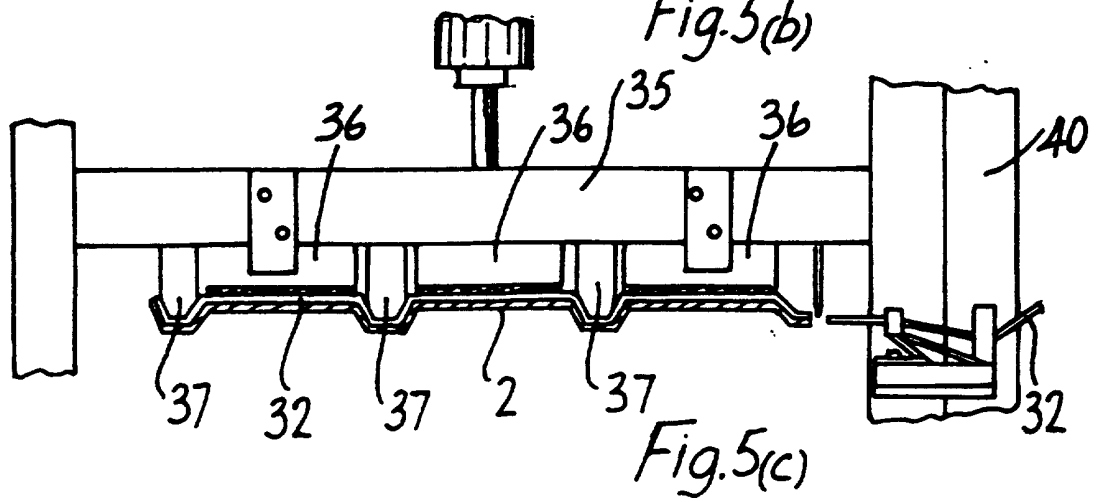
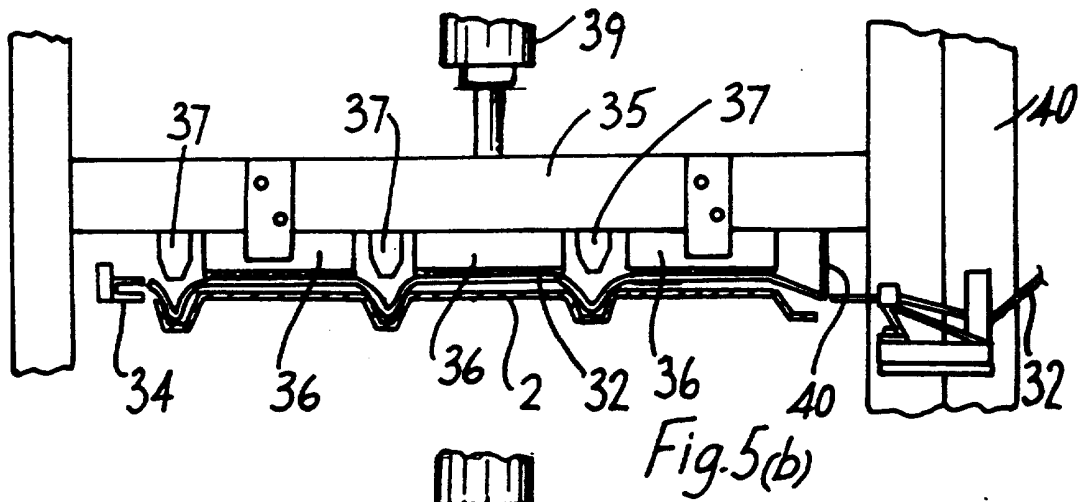
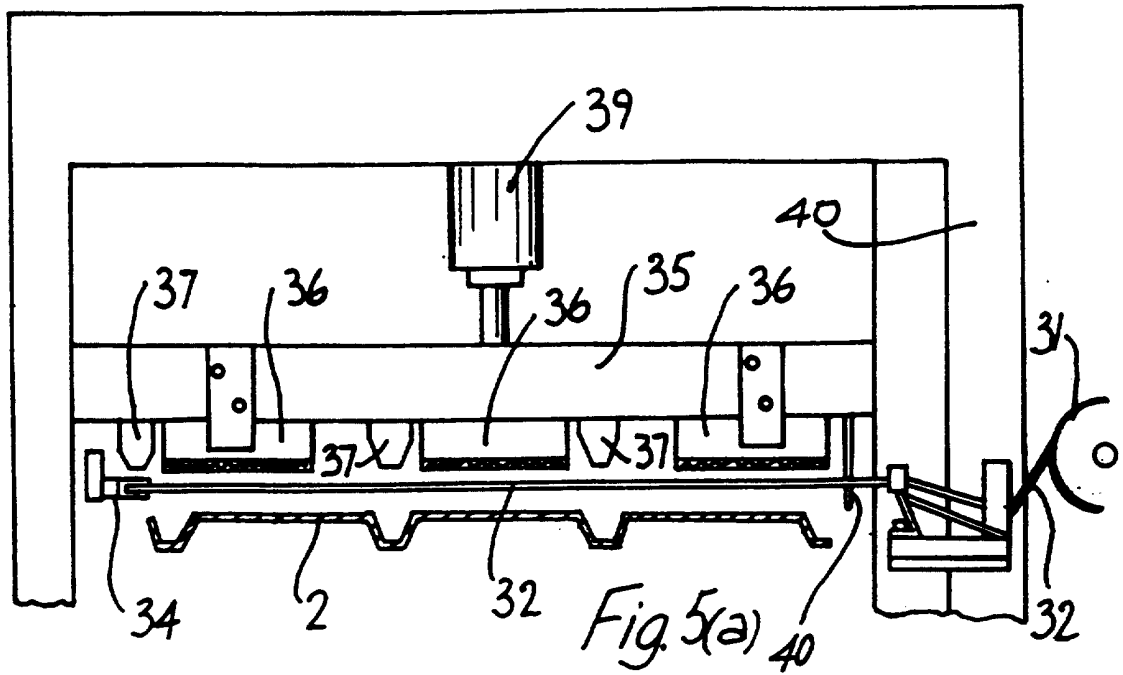

Fig. 4



5/14

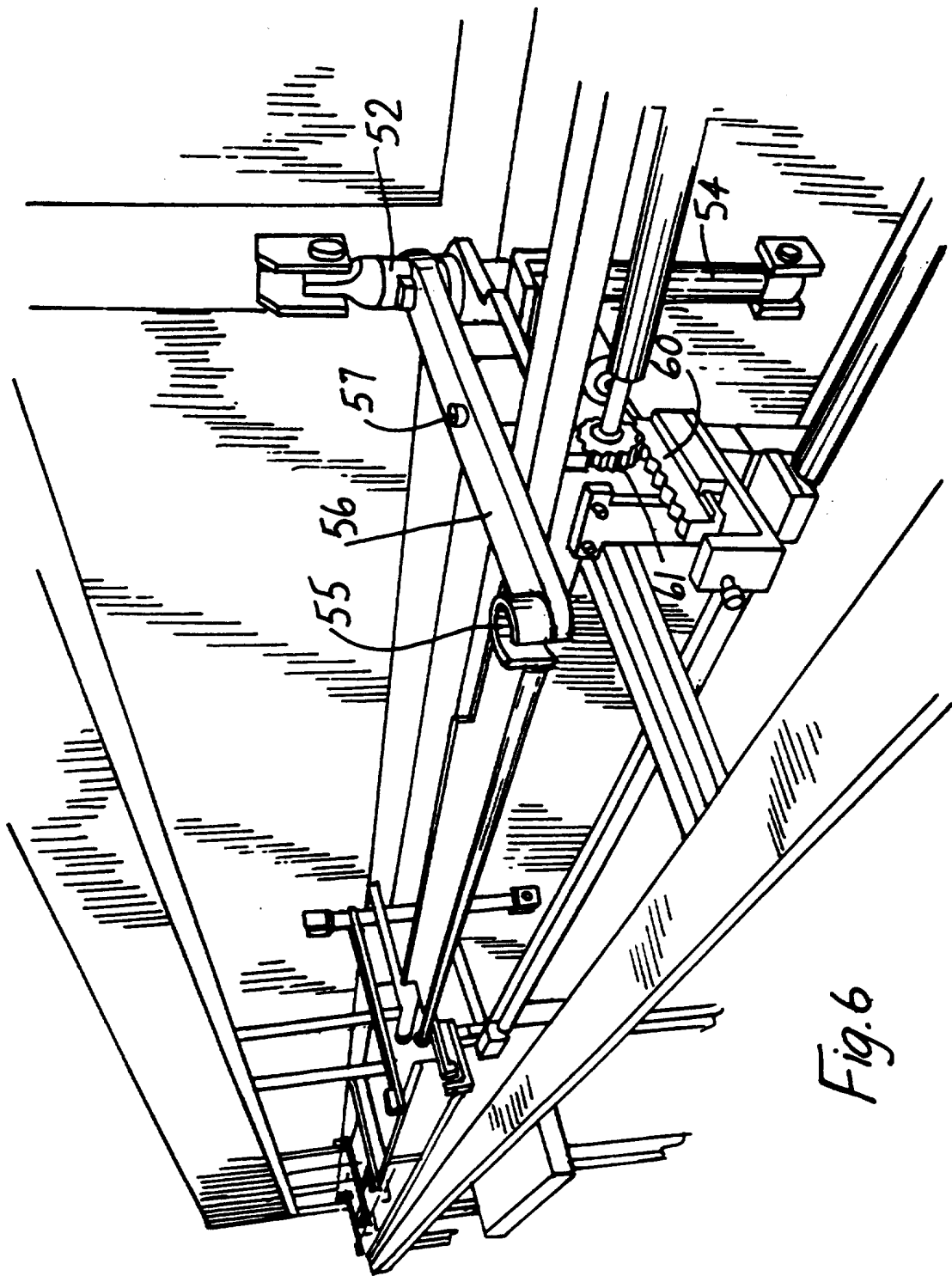

Fig. 6

6/14

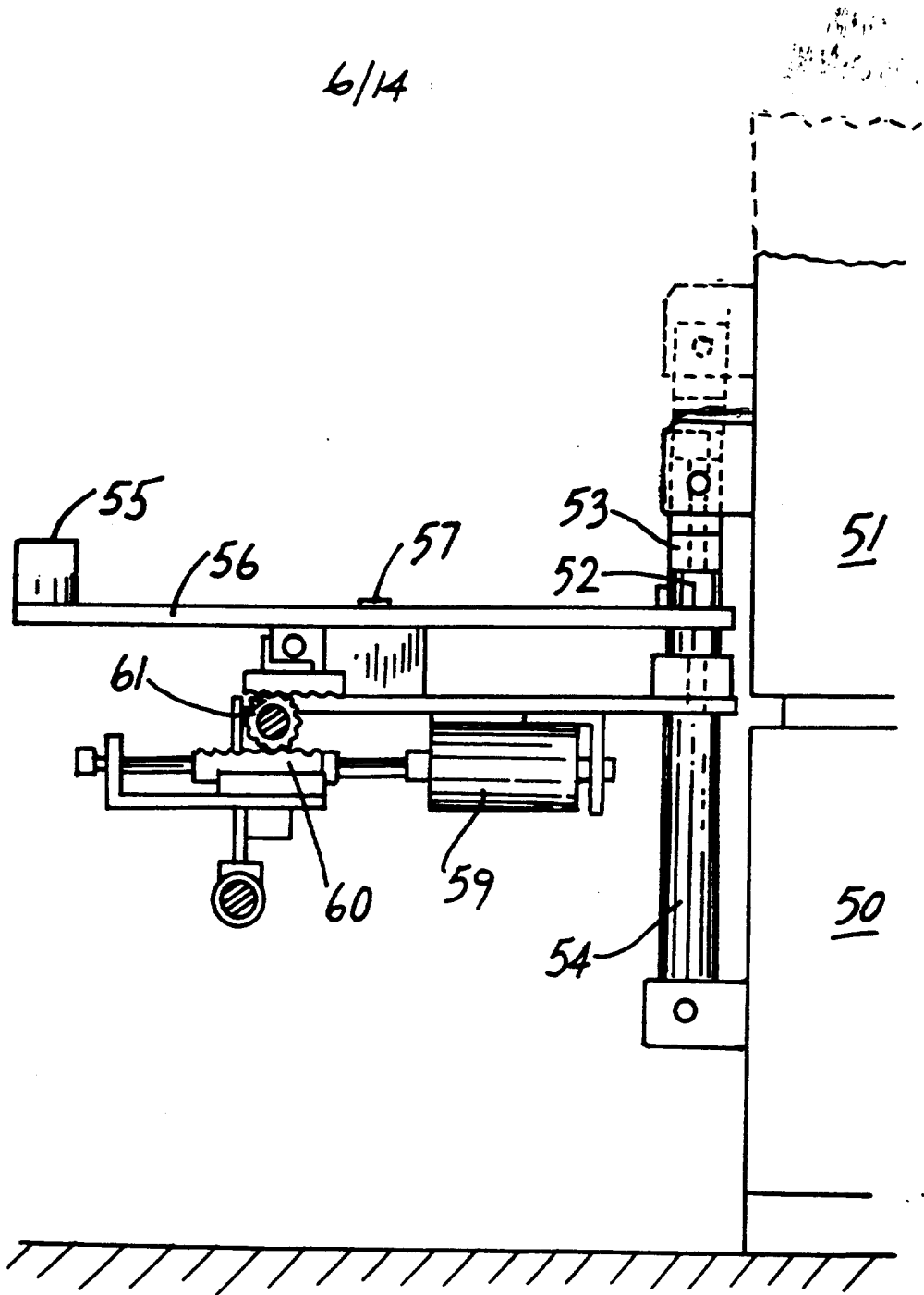
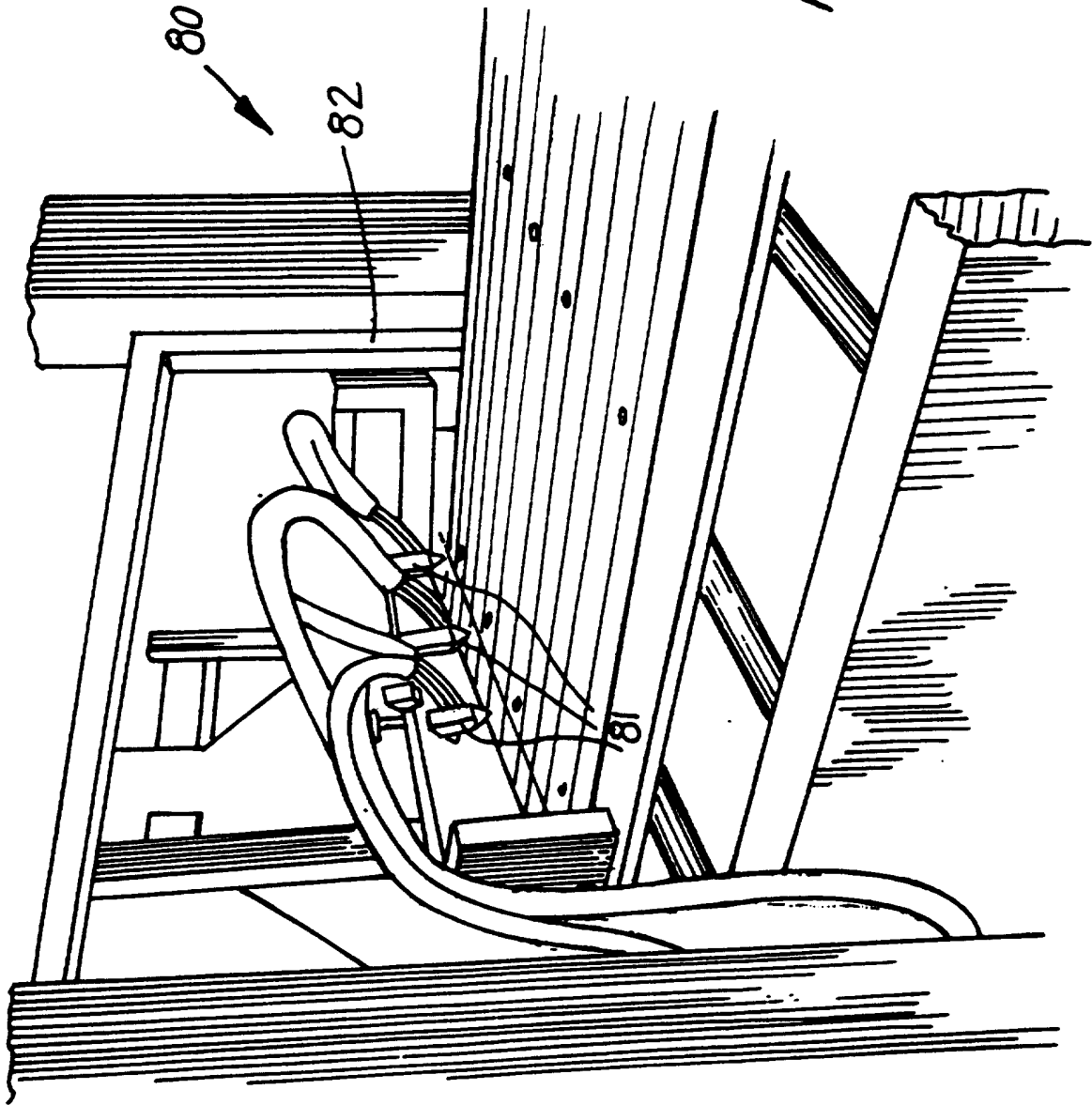

Fig. 7

7/14

Fig. 8





8/14

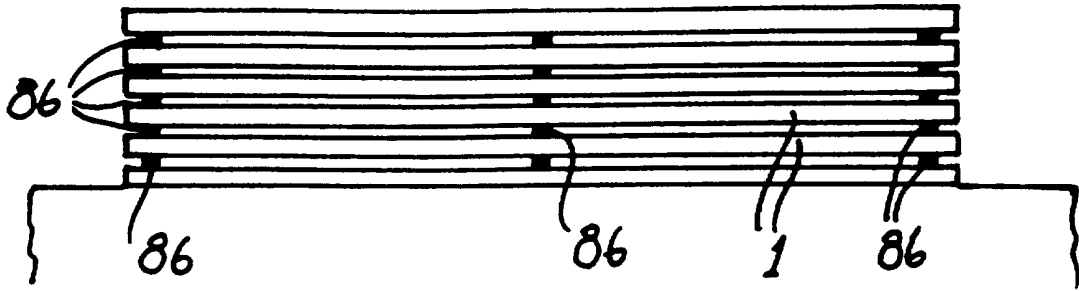

Fig. 10

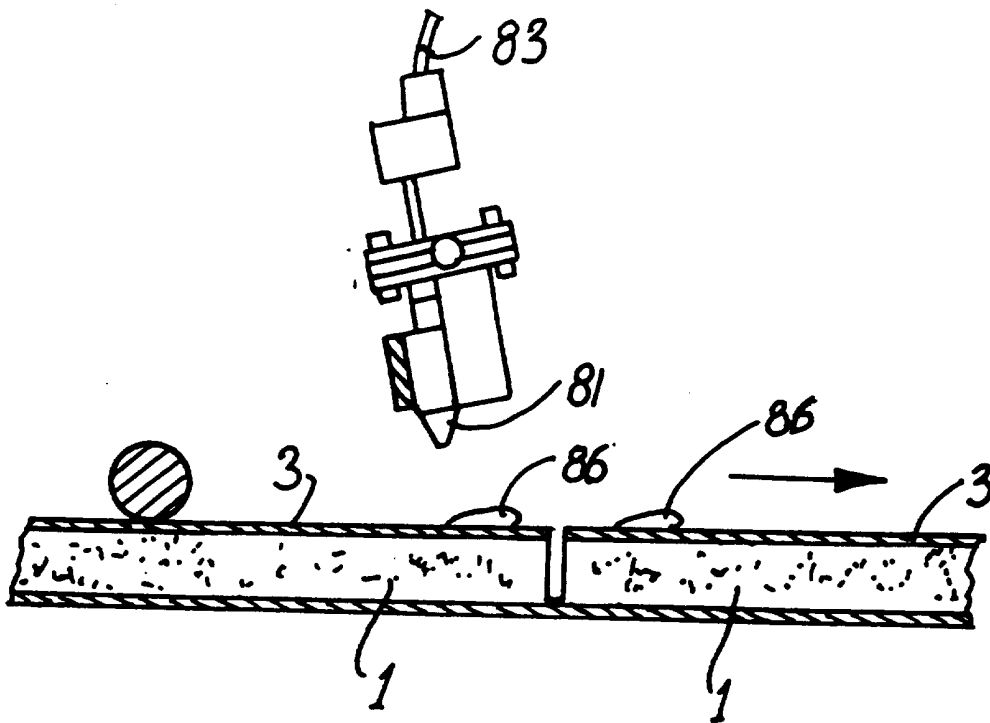

Fig. 9

9/14

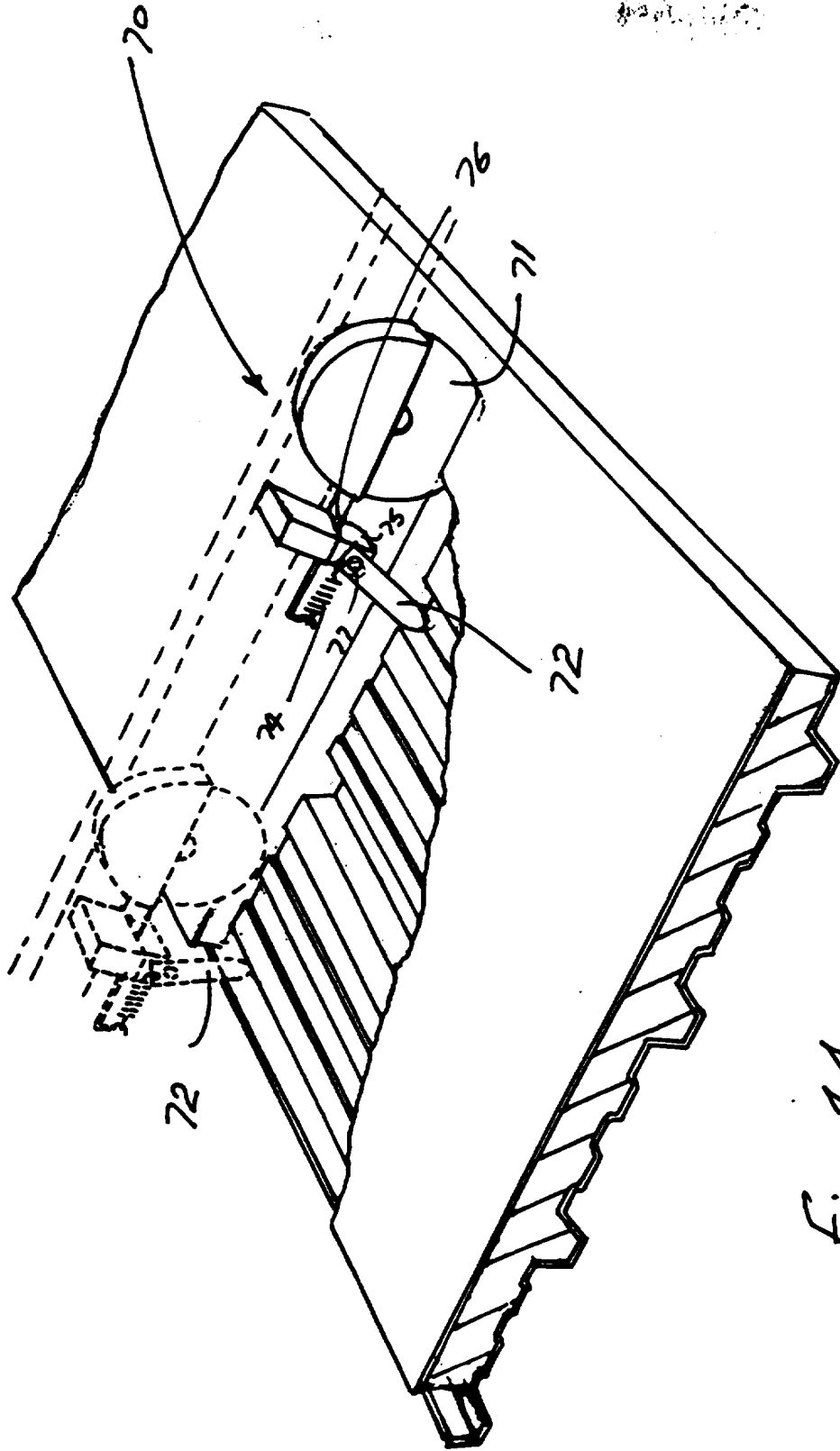

Fig. 11

10/14

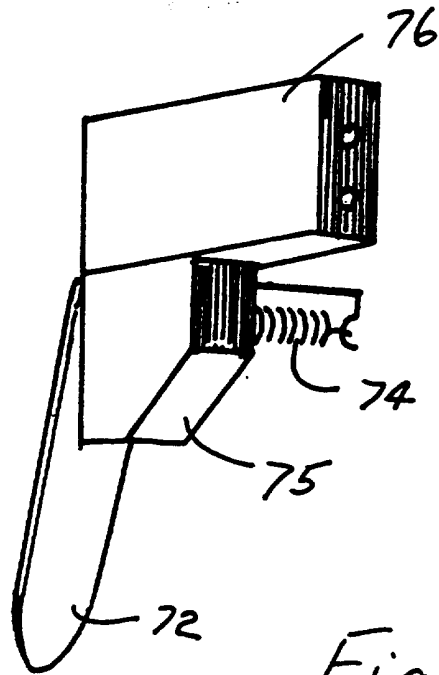

Fig. 12

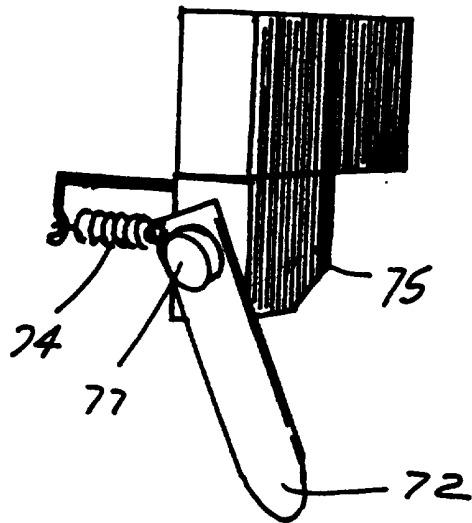

Fig. 13

11/14

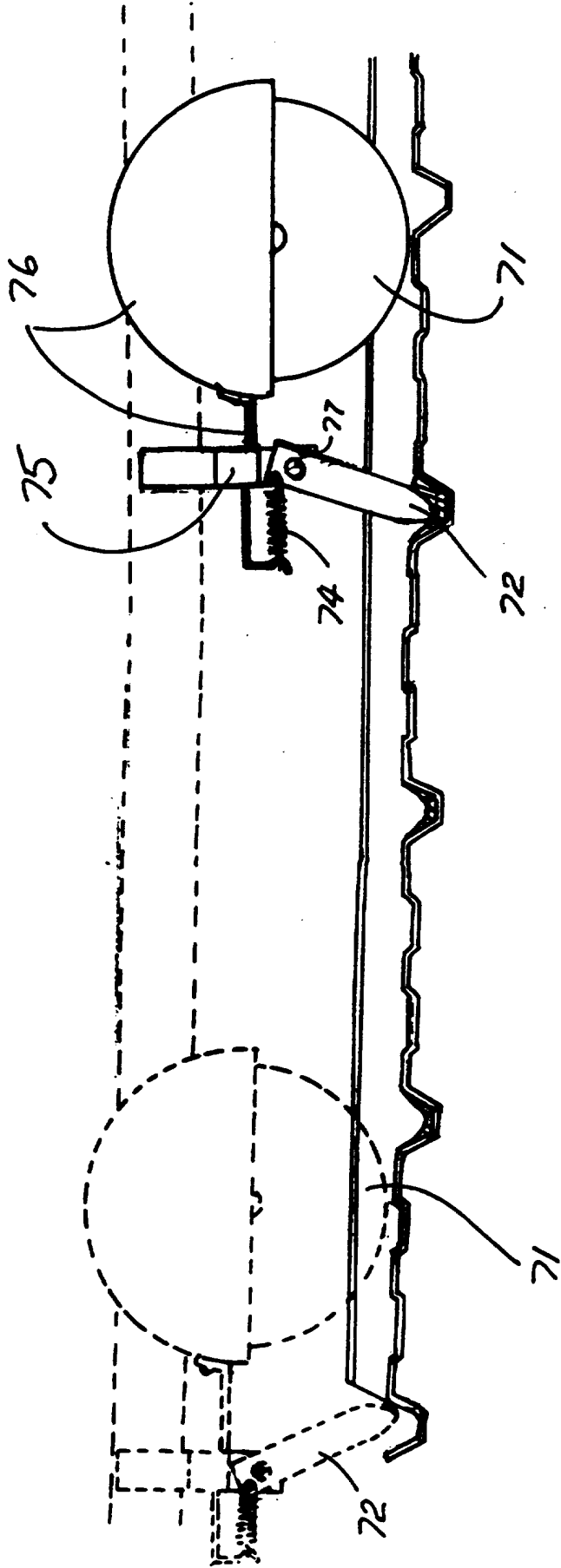

Fig. 14

12/14

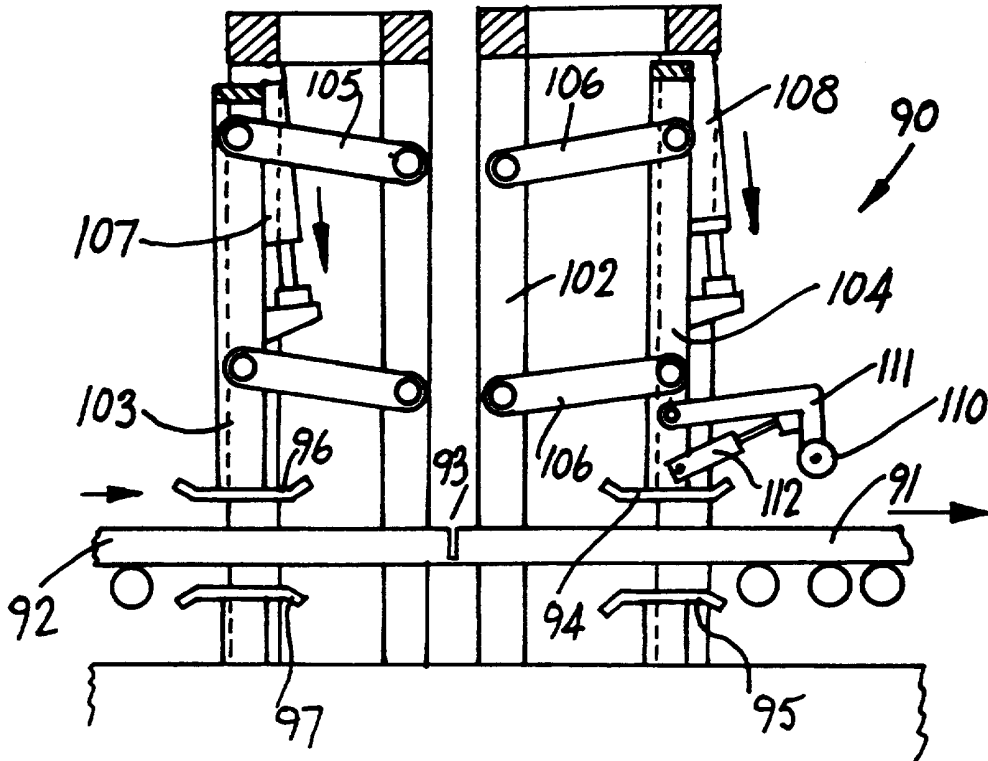

Fig. 15

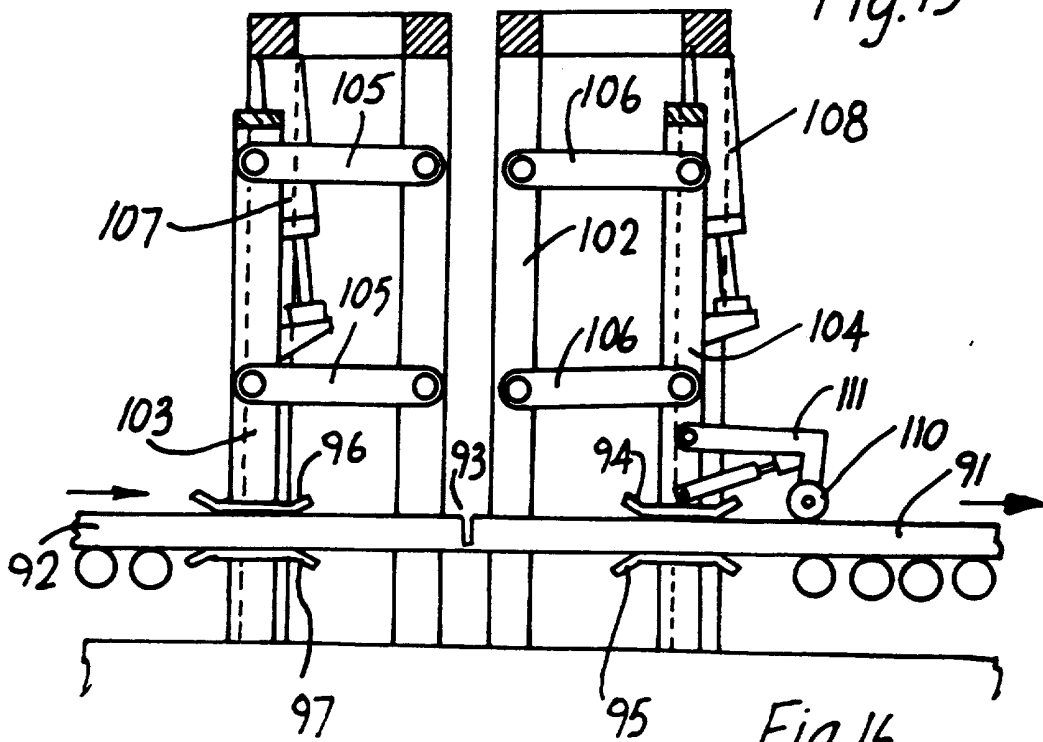

Fig. 16

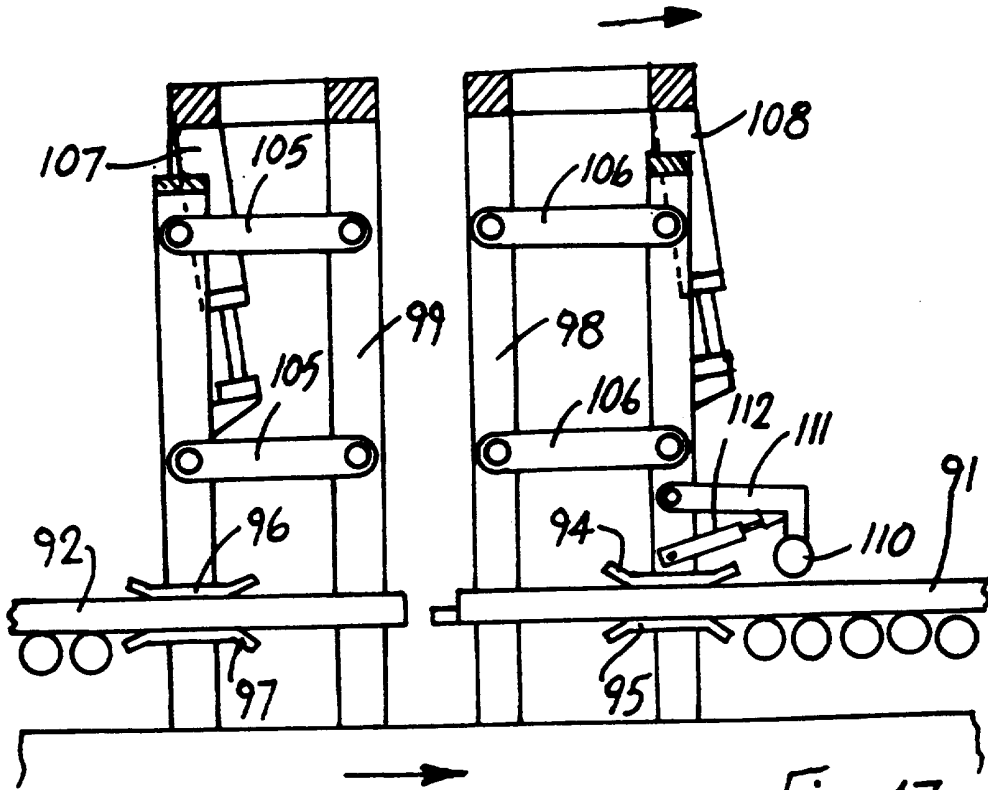

Fig. 17

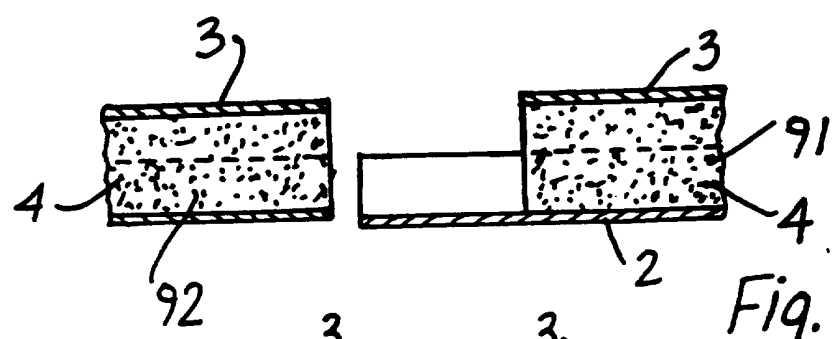

Fig. 18(b)

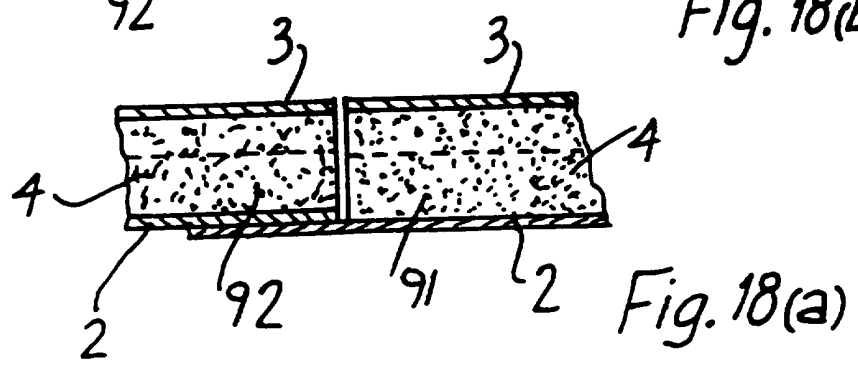
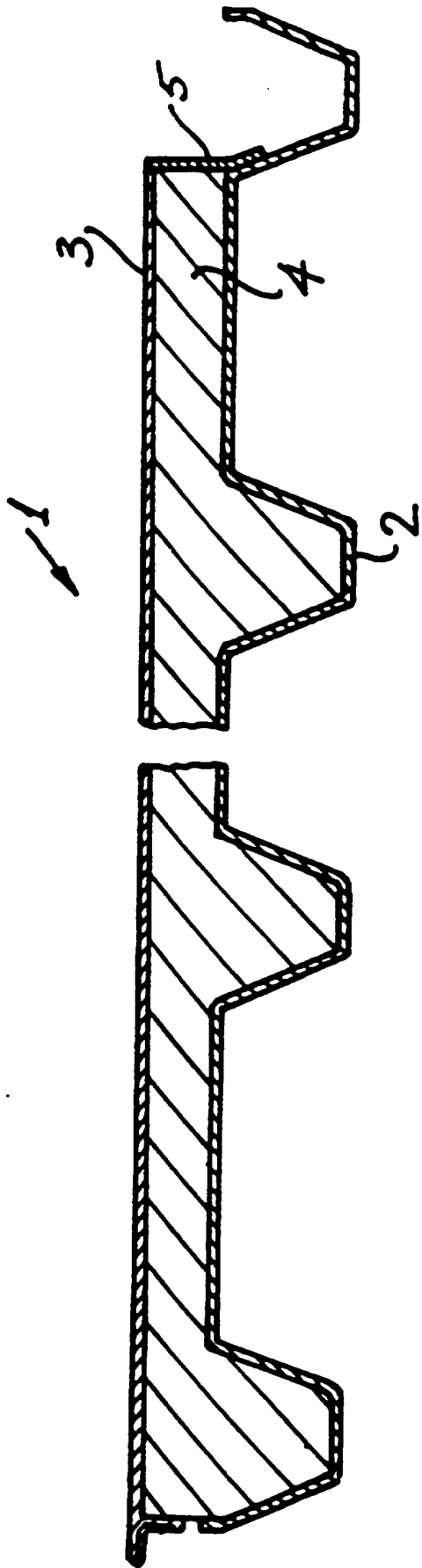

Fig. 18(a)



14/14

Fig. 19

“Method and apparatus for  
Manufacturing Insulating Panels”

Introduction

5

The invention relates to a method and apparatus for manufacturing insulating panels of the type comprising a profiled external skin and an internal backing tray having an insulating core therebetween.

10

UK-A-2227712 and UK-A-2257086 describe methods and apparatus for manufacturing insulating panels. These methods are very efficient in use, however, there is an increasing need to improve the manufacturing efficiency to cut costs and maximise the production of such insulating panels.

15

This invention is therefore directed towards providing an improved method and apparatus for efficient manufacturing of insulating panels.

Statements of Invention

20

According to the invention, there is provided a method for manufacturing an insulating panel of the type comprising a first skin and a second skin having an insulating core therebetween, the method comprising the steps of:-

25

applying a coding means to a preset location of a first skin;

conveying the first skin along a flat bed;

applying liquid insulating foam reactants onto the first skin;

30

leading a second skin continuously over the first skin to form an assembly;



heating the assembly in an oven to allow the liquid foam reactants to expand to form an insulating core between the skins;

detecting the coding means; and, in accordance with the coding means, cutting at least one skin and foam core through to the first skin.

In a preferred embodiment of the invention the coding means is a tape means, especially a reflective tape means.

Preferably, the method in this case includes the steps of:-

leading a first skin sheet from a supply reel;

applying the coding means to a preset location of the skin;

profiling the skin; and

conveying the profiled skin along a flat bed.

Ideally, the first skin is cut to a desired length prior to application of the coding means.

Preferably, the method includes the steps of:-

cutting a leading first skin to a desired length;

laying a following first skin adjacent to the leading skin to form a joint;

after cutting of the second skin and foam core detecting the coding means;

and

in accordance with the coding means, applying a separating force to separate the panels at the joint.

Preferably, the method includes the steps of:-

5

cutting a leading first skin to a desired length;

laying a following first skin adjacent to the leading first skin;

10

detecting the coding means; and

in accordance with the coding means, applying a jointing tape to the joint between the first skins.

15

Typically, the method includes the steps, after the formation of the panel of:

detecting the coding means; and, in accordance with the coding means, applying a protective material to the panel.

20

In this case, preferably the protective material is applied to the panel after cutting of the backing tray and foam core.

Ideally, the tape means is applied by:-

25

drawing tape from a supply reel;

positioning the tape at a desired location of the skin;

cutting the tape to a desired length; and

30

pressing the cut length of tape against the skin to apply the tape to the skin.

Preferably, a desired length of tape is drawn from the supply reel by operation of an indexing means. Preferably, the indexing means is an indexing ram which is operated to turn a pinion through a preset rotation corresponding to a desired length. In this case, preferably the tape is drawn over an applicator head from the supply reel and the applicator head presses the tape against the external skin to apply the tape. Ideally, the tape is retained in position on the applicator head prior to application by drawing the tape to the head. Typically, the tape is drawn to the head by applying suction. In one arrangement, the applicator head is driven from an initial rest position to receive tape from the supply reel, through an intermediate position against a blade means to cut the tape to length, to a tape applying position in which the cut tape is applied to the external skin. Preferably, the applicator head is driven by a cutting and applicator ram means, a first stroke of the ram cutting the tape to length against the blade means, and a second stroke applying the tape to the external skin.

The invention also provides an apparatus for manufacturing an insulating panel comprising:-

- 20 means for applying a coding means to a preset location of a first skin;
- conveying means for conveying the first skin along a flat bed with the outer surface of the skin lowermost;
- 25 foam applicator means for applying liquid insulating foam reactants onto the first skin;
- means for leading a second skin continuously over the first skin to form an assembly;

an oven for heating the assembly to allow the liquid foam reactants to expand to form an insulating core between the skins;

detecting means for detecting the coding means; and

5

cutting means for cutting the second skin and foam core in accordance with the coding means.

Preferably, the apparatus includes:-

10

means for leading first skin sheet from a supply reel;

means for applying coding means to a preset location of the first skin;

15

profiling means for profiling the first skin; and

conveying means for conveying the profiled first skin with the outermost surface of the skin lowermost along a flat bed.

20

Ideally, the first skin is cut to a desired length prior to application of the coding means.

In a preferred arrangement, the apparatus includes:-

25

cutting means for cutting a leading first skin to a desired length;

means for laying a following first skin adjacent to the leading first skin to form a joint;

30

means for detecting the coding means after cutting of the second skin foam core through to the profiled first skin; and

in accordance with the coding means, means for applying a separating force to separate the panels at the joint.

5 Ideally, the apparatus includes:-

cutting means for cutting a leading first skin to a desired length;

means for laying a following first skin adjacent to the leading first skin;

10

detection means for detecting the coding means; and

means for applying a jointing tape to the joint between the first skins in accordance with the coding means.

15

Preferably, the apparatus includes detection means for detecting the coding means after formation of the panel; and in accordance with the location of the coding means for applying a protective material to the panel.

20 In one arrangement, the apparatus includes:

means for drawing tape from a supply reel;

means for positioning the tape at a desired location of the first skin;

25

cutting means for cutting the tape to a desired length; and

pressing means for pressing the cut length of tape against the first skin to apply the tape to the first skin.

30

Preferably, a desired length of tape is drawn from the supply reel by operation of an indexing means. Ideally, the indexing means is an indexing ram which is operated to turn a pinion through a preset rotation corresponding to a desired length. Typically, the tape is drawn over an applicator head from the supply reel and the applicator head presses the tape against the external skin to apply the tape. Preferably, the tape is retained in position on the applicator head prior to applicator, by drawing the tape to the head. Ideally, the tape is drawn to the head by applying suction. In one embodiment of the invention, the applicator head is driven from an initial rest position to receive tape from the supply reel, through an intermediate position against a blade means to cut the tape to length, to a tape applying position in which the cut tape is applied to the skin. Preferably, the applicator head is driven by a cutting and applicator ram means, a first stroke of the ram cutting the tape to length against the blade means, and a second stroke applying the tape to the skin.

In all cases preferably the coding means is a tape means, especially a reflective tape means.

The invention also provides insulated panels whenever manufactured by a method of the invention and/or using an apparatus of the invention.

#### Brief Description of the Drawings

The invention will be more clearly understood from the following description thereof given by way of example only with reference to the accompanying drawings, in which:-

Fig. 1 is a flow chart of the method of the invention;

Fig. 2 is a perspective view of a reflective tape applicator used in the method;

Fig. 3 is a side view of the reflective tape applicator;

Fig. 4 is a perspective view of a jointing tape applicator used in the method of the invention;

5

Figs. 5(a) to 5(c) are end elevational views of the jointing tape applicator of Fig. 4, in use;

10

Fig. 6 is a perspective view of an oven with a spacer changeover apparatus used in the method of the invention;

Fig. 7 is an end cross sectional view of part of the spacer changeover apparatus;

15

Fig. 8 is a perspective view of a part of a cutting means used in the method of the invention;

Fig. 9 is another perspective view of the cutting means part of Fig. 8;

20

Fig. 10 is a perspective view of the cutting means in use;

Fig. 11 is a side elevational view illustrating the operation of the cutting means;

25

Fig. 12 is a perspective view of a protective material applicator used in the method of the invention;

Fig. 13 is a side view of the protective material applicator of Fig. 12;

Fig. 14 is a side view of a stack of panels with a protective material therebetween;

30

Fig. 15 is a side, partially cross sectional view of a panel breaker apparatus used in the method of the invention in a first position of use;

Fig. 16 is a side view of the breaker apparatus of Fig. 15 in a second position of use;

5 Fig. 17 is a side view of the breaker apparatus of Fig. 15 in a final position of use;

Figs. 18(a) and 18(b) are side, partially cross sectional views of panels separated using the apparatus of Fig. 15 to 17; and

10 Fig. 19 is a cross sectional view of a typical panel formed using the method and apparatus of the invention.

#### Detailed Description of the Invention

15 Referring to the drawings, the method and apparatus of the invention is for forming an insulated panel of the type which is illustrated in Fig. 19 and indicated generally by the reference numeral 1. The panel 1 comprises a profiled external skin 2 of steel or aluminium material, an internal backing tray 3 also of steel or aluminium material and an insulating core 4 of polyurethane or polyisocyanurate  
20 foam material which fills the space between the external skin 2 and backing tray 3. The insulated panel 1 is typically used for roofing and/or cladding systems, adjacent panels being overlapped both longitudinally and transversely to clad and/or roof a particular area.

25 Referring particularly to Fig. 1, the method according to the invention for forming the panel 1 in a substantially continuous manner comprises the step A of leading a sheet of external skin material from a reel onto a flat bed with the outermost face of the external skin 2 lowermost. Reflective tape is applied in step B to the external skin 2 at a desired location as will be described in more detail below. The  
30 desired longitudinal overlap between adjacent panels are automatically marked using an ink jet apparatus. The external skin 2 is then profiled at C and cut to



length in step D. The trailing edge of the external skin 2 of a first leading panel in the line is lifted up and placed down on the leading edge portion of the following external skin 2 in step E. As will be described in more detail below, a joint between the external skins 2 is made by automatically applying a jointing tape at F. The external skins 2 are then preheated at G prior to application of liquid foam reactants at H.

A sheet of backing tray material is led from a reel in step I, profiled in step J, and preheated in step K. The profiled backing tray 3 is then continuously applied over the overlapped external skins 2 and liquid foam reactants in step L. As the backing tray 3 is applied, a longitudinally extending side sealing tape 5 is also applied at M between the backing tray 3 and the external skin 2 to confine the foam core 4 in the desired space.

The backing tray 3 is maintained in spaced-apart relationship from the external skin 2 by appropriately sized spacer blocks. The spacer blocks may be readily changed as described in more detail below by first opening an oven in step N and changing the blocks in step O.

The liquid foam reactants are then allowed to expand to fill the space between the external skin 2 and backing tray 3 by passing the assembly through the oven in step P in which the reactants are heated and allowed to expand to the desired thickness of foam insulating core 4.

The output from the oven is a continuous longitudinal sheet of insulating panels 1 interconnected by the jointing tape. As will be described in more detail below, at the joint between adjacent external skins, the backing tray 3 and foam core 4 are cut in a single cutting stage through to the internal (or upper) face of the external skin 2 in step Q. A protective material is applied to the exposed face of the backing tray 3 in step R and adjacent panels 1 are separated at the joint in step S in preparation for stacking and packaging.

Referring particularly to Figs. 2 and 3, there is illustrated a reflective tape applicator 10 used in the method of the invention for applying a length of reflective tape 11 to a desired location, typically adjacent a side edge, of the external skin 2. The reflective tape 16 is led from a supply reel 12 over guide wheels 13 to a grooved index wheel 14 and on to an applicator head 15. A desired length of tape 16 is drawn from the supply reel by an indexing ram 20 carrying a rack 21 which engages with a pinion 21 of the index wheel 14 to deliver the tape to the applicator head 15. The tape 16 may be applied in different lengths to initiate particular processing parameters. Typically, the indexing ram 20 is operated once to deliver a length of tape 16 for a right hand panel and may be operated twice to deliver a double length of tape 16 to indicate a left hand panel.

The tape 16 is held in place on the applicator head 15 by suction. The applicator head 15 is driven by a cutting and applicator ram 25 from an initial rest position (Fig. 3) to receive reflective tape, through an intermediate position against a blade 26 to cut the tape to length, to a final tape applying position (Fig. 2) in which the cut tape is applied to the external skin 2. When the length of tape 11 is applied, the ram 25 is released and the process is repeated to apply a length of tape 11 at desired locations of the external skin 2.

The length of reflective tape 11 applied to the upper face of the external skin 2 is used to automatically actuate various further steps in the method of the invention. It may be used, for example, to automatically activate the cutting means for cutting the backing tray and foam core through to the external skin. It may also be used to automatically activate the breaking means to separate the cut panels at the joint. In addition, the reflective tape 11 may trigger the operation of the jointing tape applying apparatus described below and/or the protective material applicator which is also described below.

Alternatively coding means may be provided by means other than a reflective tape. The coding means may, for example be or include a bar code which may be applied to a tape or possibly directly to a skin.

5 Referring particularly to Figs. 4 and 5, there is illustrated an automatic jointing tape applicator 30 used in the method of the invention to apply a jointing tape at the joint between adjacent external skins 2. Jointing tape 32 is led from a supply reel 31 to a guide 33. Gripper jaws 34 are then used to grip the free end of the tape 32 and to draw it across the bed on which the profiled external skin is travelling. The length of the jointing tape 32 drawn across the bed is longer than  
10 the width of the skin 2 to take account of the profile of the skin 2.

The length of tape 32 is then drawn under an applicator head 35 which has a number of sections 36 corresponding to the flat portions of the profile of the external skin 2 and a number of sections 37 corresponding to the corrugations of  
15 the external skin 2. The applicator head 35 is moved up and down by a ram 39 and the outer two of the head sections 36 may be moved in and out by a second ram (not shown).

20 As the tape 32 is drawn under the applicator head 35, it is cut to length by engaging against a blade 40. The outer two applicator head sections 36 are then moved from the outer position illustrated in Fig. 5(a) to the inner position illustrated in Fig. 5(b) to form the tape 32 into loops in the region of the corrugations. The ram 39 is then operated to drive the applicator head 35  
25 downwardly to apply the jointing tape 32 across the profile of the external skins 2 at the overlapped joint between adjacent skins 2 as illustrated in Fig. 5(c).

The tape 32 is maintained in position on the applicator head sections 36 by suction.

The line of external skins 2 is not stopped while the jointing operation takes place as the applicator 30 is mounted on a carriage 40 which travels with the line to optimise production efficiency.

5 The jointing tape applicator 30 may be automatically operated when the reflective tape described above is detected by a suitable detector.

Referring particularly to Figs. 6 and 7, in the method of the invention the assembly of the external skin 2, backing tray 3 and liquid foam reactants are heated in a long oven having a top bed 50 and a bottom bed 51. During the heating process the spacing between the backing tray 3 and external skin 2 is maintained by a continuous course of spacer blocks (not shown) on both sides. The top bed 50 is maintained at the desired spaced position from the bottom bed 51 by a plurality of first spacers 52 which are each interposed on rods 53 interconnecting the top and bottom oven beds 50, 51. The top bed 51 is lifted up from the bottom bed 50 by lifting rams 54.

15 A quick safe changeover from one thickness of panel to another is effected by lifting up the top bed 51 on operation of the rams 54 and changing over to second spacers 55 which in this case are thicker than the first spacers 52.

20 The spacers 52 are each mounted on a spacer arm 56. The top bed 51 is lifted up from the bottom bed 50 by operating the rams 54. The spacer arms 56 are then pushed out by pusher rams. Each spacer arm 56 is pivotally mounted at 57 for rotation from a first position in which the first spacer 52 is between the beds 50, 51 through 180° to a second position in which the first spacer 52 is removed and the second spacer 55 is in position between the beds 50, 51.

25 All of the spacer arms 56 may be rotated substantially at the same time by operating a single or a number of spacer arm rotating rams 59. A ram 59 rotates the arm 56 through a rack 60 and pinion 61 arrangement.

30

The pusher rams are then reversed to push the second spacers 55 into position before closing down the top bed 51 of the oven on operation of retraction of the main rams 54.

5

Referring particularly to Fig. 8 to 11, cutting means 70 for cutting the backing tray 3 and foam core 4 at the joint between overlapping skins 2 comprises a leading cutting means provided by a cross cut saw 71 and a following blade 72. The blade 72 is operated against the biasing of a spring 74. The blade 72 is pivotally mounted by a pivot pin 77 on a bracket 75 which is in turn mounted to the housing 76 of the cross cut saw 71 so that the blade 72 travels across following the cross cut saw 71. The blade 72 is angled forwardly in the rest position and is held in that position by the spring 74. As the blade 72 is moved across, it is angled back and joggled up and down to provide a clean cutting action.

10  
15

The cross cut saw 71 is set so that the cutting edge is spaced above the upper face of the flat surface of the external skin 2. The blade 72 is set so that as it moves across its cutting edge just engages the foam core.

20

As will be particularly apparent from Fig. 11, when the joint between external skins is detected, particularly using the reflective tape as described above, the cutting means 70 is automatically operated to cut the backing tray 3 and foam core 4. The cross cut saw 71 makes a first cut in which the blade 72 travels to cut through the core providing, in a very efficient way, a relatively clean cut.

25

For maximum processing efficiency, the cutting means 70 is mounted on a carriage (not shown) which travels with the panel as it progresses along the line.

30

A detector may be used to detect the position of the corrugations of the external skin as the blade 72 travels across. When a corrugation is detected, a ram may be operated to drive the blade 72 down to engage the corrugation and to cut the foam

core 4 in the corrugation through to the upper face of the external skin. The blade 72 may also be vibrated by a vibrating means (not shown) to provide a clean cut.

5 Referring particularly to Figs. 12 and 13, there is illustrated a protective material applicator means 80 used in the method of the invention . The applicator means 80 in this case comprises three nozzles 81 which are mounted on and spaced-apart across a carriage 82 above the upper face of the backing tray 3 of the panels 1. Each of the nozzles 81 is supplied with a flowable protective material through individual supply pipes 83. On detection of the reflective tape applied as  
10 described above, the protective material is automatically applied in a number of blobs 85 at spaced locations along and across the panels 1. The blobs 85 of protective material harden to provide spacers 86 between adjacent panels 1 when they are stacked as illustrated in Fig. 10 for storage and transportation. In this way, damage to the surface of the panels is substantially prevented.

15 In this case, the protective material is a hot melt adhesive which is prepared from granules stored in a storage vessel and delivered on demand to a heater which melts the material into a flowable form which is then delivered along the pipes 83 to the nozzles 81. The hot melt adhesive cures rapidly in ambient conditions to  
20 form the panel spacers 86.

Referring to Figs. 15 to 17, there is illustrated a panel breaking apparatus 90 used in the method of the invention for separating a leading panel 91 from a trailing panel 92 at the cut joint 93. A first clamp comprising a first upper clamping head 94 and a first lower clamping head 95 grips the leading panel 91. A second clamp  
25 comprising a second upper clamping head 96 and a second lower clamping head 97 grips the trailing panel 91. The first and second clamps are mounted on separate carriages 98, 99 which are moved apart from the position illustrated in Figs. 15 and 16 to the separated position illustrated in Fig. 17 to separate the

30

adjacent panels 91, 92 at the joint from the joined position illustrated in Fig. 18(a) to the separated position illustrated in Fig. 18(b).

5 The carriages 98, 99 each comprise a post 101, 102 which is fixed relative to the respective panel 91, 92 and a movable post 103, 104. The posts 101, 103 and 102, 104 are interconnected by pivot arms 105, 106 and the posts 101, 102, 103, 104 are also interconnected by respective rams 107, 108. To engage the upper clamp head 94, 96 with the adjacent panels 91, 92, the rams 107, 108 are operated from the raised release position illustrated in Fig. 15 to move the posts 103, 104 on the  
10 pivot arms 105, 106 to the extended engaged position illustrated in Figs. 16 and 17. The lower clamps 95, 97 are also operated by lower rams, not shown.

At least the leading clamp may be provided with a roller 110 on a guide arm 111 pivotally connected to the movable post 104 and movable by a guide ram 112.  
15 The roller 110 rides on the surface of the backing tray 3 of the panel 91 to position the upper clamps 94, 96 as short a distance as possible above the backing tray. In this way, the distance through which the upper clamp heads 94, 96 travel is minimised. Consequently, the speed of the panel separation process is optimised.

20 It will be noted that the lower clamp heads 95 and 97 are spaced in the release position illustrated in Fig. 15 below the lower surface of the panels 91, 92. This ensures that grit and dirt are not trapped which could lead to damage to the exposed surface of the panel.

25 The carriages 98, 99 on which the clamps are mounted travel with the panels as they progress along the production line. This is important in ensuring that processing time is optimised as the panels are not stopped during the separation process.

30 The separating apparatus may be automatically actuated by a suitable detector picking up the reflective tape applied as described above.

It will also be appreciated that the breaker means may include a blade means to provide a smooth cut of the foam core through to the lower skin, on operation of the breaking means, e.g. on operation of the clamping means and/or on application of the separation force.

The invention provides a highly optimised and efficient method and apparatus for manufacturing insulating panels.

The invention is not limited to the embodiments hereinbefore described which may be varied in detail.



**CLAIMS**

1. A method for manufacturing an insulating panel of the type comprising a first skin and a second skin having an insulating core therebetween, the method comprising the steps of:-
- 5
- applying a coding means to a preset location of a first skin;
- conveying the first skin along a flat bed with the outer surface of the skin lowermost;
- 10
- applying liquid insulating foam reactants onto the first skin;
- leading a second skin continuously over the first skin to form an assembly;
- 15
- heating the assembly in an oven to allow the liquid foam reactants to expand to form an insulating core between the skins;
- 20
- detecting the coding means and, in accordance with the coding means, cutting the second skin and foam core.
2. A method as claimed in claim 1 wherein the coding means is a tape means.
- 25
3. A method as claimed in claim 1 or 2 wherein the coding means is a reflective tape means.
4. A method as claimed in any preceding claim wherein the first skin is an external skin and the second skin is an internal backing tray.
- 30
5. A method as claimed in claim 4 including the steps of:-

leading the external skin sheet from a supply reel;

applying the reflective tape to a preset location on the external skin;

5

profiling the external skin; and

conveying the profiled external skin with the outermost surface of the skin lowermost along a flat bed.

10

6. A method as claimed in claim 5 wherein the external skin is cut to a desired length prior to application of the reflective tape.

7. A method as claimed in any of claims 1 to 6 including the steps of:-

15

cutting a leading first skin to a desired length;

laying a following first skin adjacent to the leading first skin to form a joint;

20

after cutting of the second skin and foam core, detecting the coding means; and

in accordance with the coding means, applying a separating force to separate the panels at the joint.

25

8. A method as claimed in any of claims 1 to 7 including the steps of:-

cutting a leading first skin to a desired length;

30

laying a following first skin adjacent to the leading first skin;

detecting the coding means; and

in accordance with the coding means applying a jointing tape to the  
joint between the first skins.

5

9. A method as claimed in any of claims 1 to 8 including the steps, after the formation of the panel of:-

10

detecting the coding means; and in accordance with the coding means applying a protective material to the panel.

10. A method as claimed in claim 9 wherein the protective material is applied to the panel after cutting of the second skin and foam core.

15

11. A method as claimed in any of claims 2 to 10 wherein the tape means is applied by:-

drawing tape from a supply reel;

20

positioning the tape at a desired location of the first skin;

cutting the tape to a desired length; and

25

pressing the cut length of tape against the first skin to apply the tape to the external skin.

12. A method as claimed in claim 11 wherein a desired length of tape is drawn from the supply reel by operation of an indexing means.

30

13. A method as claimed in claim 12 wherein the indexing means is an indexing ram which is operated to turn a pinion through a preset rotation corresponding to a desired length.
- 5 14. A method as claimed in any of claims 12 to 13 wherein the tape is drawn over an applicator head from the supply reel and the applicator head presses the tape against the first skin to apply the tape.
- 10 15. A method as claimed in claim 14 wherein the tape is retained in position on the applicator head prior to application by drawing the tape to the head.
16. A method as claimed in claim 15 wherein the tape is drawn to the head by applying suction.
- 15 17. A method as claimed in any of claims 14 to 16 wherein the applicator head is driven from an initial rest position to receive tape from the supply reel, through an intermediate position against a blade means to cut the tape to length, to a tape applying position in which the cut tape is applied to the first skin.
- 20 18. A method as claimed in claim 17 wherein the applicator head is driven by a cutting and applicator ram means, a first stroke of the ram cutting the tape to length against the blade means, and a second stroke applying the tape to the first skin.
- 25 19. A method as claimed in any of claims 5 to 18 wherein the first skin is an external skin and the second skin is an internal backing tray.
- 30 20. A method for manufacturing an insulating panel as claimed in any of claims 1 to 19 substantially as hereinbefore described with reference to the accompanying drawings.

21. Apparatus for manufacturing an insulating panel comprising:-

5

means for applying a coding means to a preset location of a first skin;

conveying means for conveying the first skin along a flat bed with the outer surface of the skin lowermost;

10

foam applicator means for applying liquid insulating foam reactants onto the first skin;

means for leading a second skin continuously over the first skin to form an assembly;

15

an oven for heating the assembly to allow the liquid foam reactants to expand to form an insulating core between the skins;

detecting means for detecting the coding means; and

20

cutting means for cutting the second skin and foam core in accordance with the coding means.

22. Apparatus as claimed in claim 21 including:-

25

means for leading a first skin sheet from a supply reel;

means for applying coding means to a preset location of the first skin;

30

profiling means for profiling the first skin; and

conveying means for conveying the profiled first skin with the outermost surface of the skin lowermost along a flat bed.

5        23.    Apparatus as claimed in claim 22 wherein the first skin is cut to a desired length prior to application of the coding means.

24.    Apparatus as claimed in claim 22 or 23 including:-

10                    means for cutting a leading first skin to a desired length;

                  means for laying a following first skin adjacent to the leading first skin to form a joint;

15                    means for detecting the coding means after cutting of the second skin and foam core; and

                  in accordance with the coding means, means for applying a separating force to separate the panels at the joint.

20        25.    Apparatus as claimed in any of claims 22 to 24 including:-

                  cutting means for cutting a leading first skin to a desired length;

25                    means for laying a following first skin adjacent to the leading first skin;

                  detection means for detecting the coding means; and

30                    means for applying a jointing tape to the joint between the first skins in accordance with the coding means.

- 5 26. Apparatus as claimed in any of claims 22 to 25 including detection means for detecting the location of the coding means after formation of the panel; and means for applying a protective material to the panel in accordance with the coding means.
- 10 27. Apparatus as claimed in any of claims 22 to 26 wherein the coding means is a tape means and the apparatus includes:-
- means for drawing tape from a supply reel;
- means for positioning the tape at a desired location of the first skin;
- cutting means for cutting the tape to a desired length; and
- 15 pressing means for pressing the cut length of tape against the first skin to apply the tape to the first skin.
- 20 28. Apparatus as claimed in claim 27 wherein a desired length of tape is drawn from the supply reel by operation of an indexing means.
- 25 29. Apparatus as claimed in claim 28 wherein the indexing means is an indexing ram which is operated to turn a pinion through a preset rotation corresponding to a desired length.
- 30 30. Apparatus as claimed in any of claims 27 to 29 wherein the tape is drawn over an applicator head from the supply reel and the applicator head presses the tape against the first skin to apply the tape.
31. Apparatus as claimed in claim 30 wherein the tape is retained in position on the applicator head prior to application by drawing the tape to the head.

32. Apparatus as claimed in claim 31 wherein the tape is drawn to the head by applying suction.
- 5 33. Apparatus as claimed in any of claims 30 to 32 wherein the applicator head is driven from an initial rest position to receive tape from the supply reel, through an intermediate position against a blade means to cut the tape to length, to a tape applying position in which the cut tape is applied to the external skin.
- 10 34. Apparatus as claimed in claim 33 wherein the applicator head is driven by a cutting and applicator ram means, a first stroke of the ram cutting the tape to length against the blade means, and a second stroke applying the tape to the external skin.
- 15 35. Apparatus for manufacturing an insulating panel as claimed in any of claims 29 to 34 substantially as hereinbefore described with reference to the accompanying drawings.
- 20 36. An insulating panel whenever produced by a method as claimed in any of claims 1 to 20 and/or using an apparatus as claimed in any of claims 21 to 35.





Application No: GB 9811402.8  
Claims searched: 1 to 36

Examiner: R.J.MIRAMS  
Date of search: 21 August 1998

**Patents Act 1977  
Search Report under Section 17**

**Databases searched:**

UK Patent Office collections, including GB, EP, WO & US patent specifications, in:  
UK CI (Ed.P): B5N  
Int CI (Ed.6): B29C 44/32, B32B 5/20, 31/00. E04C 2/292.  
Other: ONLINE: WPI.

**Documents considered to be relevant:**

Category	Identity of document and relevant passage	Relevant to claims
X	GB2257086A (Kingspan Research) e.g. claims 15 to 17	at least 1 and 21 to 26
X	GB2227712A (Kingspan Research) e.g. claims 8 to 10	at least 1 and 21 to 26
A	GB2309412A (Kingspan Research)	

X Document indicating lack of novelty or inventive step	A Document indicating technological background and/or state of the art.
Y Document indicating lack of inventive step if combined with one or more other documents of same category.	P Document published on or after the declared priority date but before the filing date of this invention.
& Member of the same patent family	E Patent document published on or after, but with priority date earlier than, the filing date of this application.