

**(12) PATENT**  
**(19) AUSTRALIAN PATENT OFFICE**

**(11) Application No. AU 199661939 B2**  
**(10) Patent No. 708440**

(54) Title  
A course guide apparatus used for a competitive game simulation machine

(51)<sup>6</sup> International Patent Classification(s)  
A63F 009/14

(21) Application No: 199661939 (22) Application Date: 1996 .08 .06

(30) Priority Data

(31) Number (32) Date (33) Country  
7-201028 1995 .08 .07 JP

(43) Publication Date : 1997 .02 .13  
(43) Publication Journal Date : 1997 .02 .13  
(44) Accepted Journal Date : 1999 .08 .05

(71) Applicant(s)  
Konami Co., Ltd.

(72) Inventor(s)  
Toshiaki Nakagawa; Takashi Yamaguchi; Kohichi Hayashida

(74) Agent/Attorney  
SPRUSON and FERGUSON,GPO Box 3898,SYDNEY NSW 2001

(56) Related Art  
EP 633045  
EP 516160  
JP 01-112490

A Course Guide Apparatus Used for a Competitive  
Game Simulation Machine

ABSTRACT

This invention relates to a course guide apparatus used for a competitive  
5 game machine (1) with a plurality of race courses, and a plurality of moving objects  
(H) competing a certain game. The course guide apparatus according to this  
invention has a course indicator (8) for indicating the course on which the plurality  
of moving objects (H) compete in the certain game, and the course indicator (8) is  
mounted along a lengthwise direction of the plurality of race courses; and a  
10 controller (3) for controlling the course indicator (8) so as to indicate the selected  
course.



**AUSTRALIA**  
**PATENTS ACT 1990**

**COMPLETE SPECIFICATION**

**FOR A STANDARD PATENT**

**ORIGINAL**

---

Name and Address  
of Applicant: Konami Co., Ltd.  
3-2, Minatojimanakamachi 7-chome  
Chuo-ku, Kobe-shi  
Hyogo-ken  
JAPAN

Actual Inventor(s): Toshiaki Nakagawa, Takashi Yamaguchi and Kohichi  
Hayashida

Address for Service: Spruson & Ferguson, Patent Attorneys  
Level 33 St Martins Tower, 31 Market Street  
Sydney, New South Wales, 2000, Australia

Invention Title: A Course Guide Apparatus Used for a Competitive Game  
Simulation Machine

The following statement is a full description of this invention, including the best method of performing it known to me/us:-

**TITLE OF THE INVENTION**

A Course Guide Apparatus used for A COMPETITIVE GAME  
SIMULATION MACHINE

**BACKGROUND OF THE INVENTION AND RELATED ART STATEMENT**

5 The present invention relates to a competitive game  
simulation machine in which moving objects resembling  
racehorses, automobiles, bicycles or soccer players, for  
example, are caused to compete in running a simulated race on  
a playing area resembling a racing track or field. More  
10 particularly this invention relates to a course guide apparatus  
used for the aforementioned competitive game simulation  
machine.

The prior art to which this invention is related discloses  
a competitive game simulation machine including a plurality of  
15 moving objects resembling, for instance, racehorses, bicycles  
or automobiles, and a race course in the playing area. In this  
conventional game machine, the plurality of moving objects  
compete each other on the race course and the first one to reach  
a finish line will be determined to be a winner. In this  
20 conventional game machine, the player plays a game in such a  
way that he or she bets money (or token) on one or more of the  
moving objects which he or she would consider winning the game.

In this conventional game machine, a loop track is formed  
in a competition field. And the game is played in such a manner

that a plurality of moving objects are aligned on a starting line first and begin running on the loop track in a predetermined direction upon receiving a start signal.

In the aforementioned conventional game simulation  
5 machine, however, a plurality of race courses are generally provided in the track and the particular race course is to be automatically selected by the game simulation machine. The player of course knows which course is used for the game about to begin at the time he or she chooses the one of race courses.  
10 However, it does not necessarily means that the player knows exactly where the race course begins or ends, or to which direction the moving objects move by looking at the track on a game board. These features, such as a start line, finish line or a running direction, of the selected course would rather be  
15 recognized after starting the game by observing the movements of the moving objects.

With this conventional game machine, the player, however, can not take into consideration, while betting, the  
aforementioned features associated with the particular course  
20 which would affect the performance of the moving objects because one of the moving object is set to perform well in a short distance course, the other one is set to perform well in the long distance course, or some other are set to perform well in the curved courses.

25 As these features associated with the race courses may play

important roll in predicting the winner, without knowing these features of the course prior to the game would likely make predictions by the players monotonous and loss of the interest of the game will likely result.

#### SUMMARY OF THE INVENTION

5 It is the object of the present invention to substantially overcome or at least ameliorate one or more of the above disadvantages.

Accordingly, this invention is directed to a course guide apparatus used for a competitive game machine having a plurality of race courses, and a plurality of moving objects competing a certain game, the course guide apparatus comprising:

10 a course indicator for indicating the course on which the plurality of moving objects compete in the certain game and the course indicator is mounted along a length wise direction of the plurality of race courses;

a controller for controlling the course indicator so as to indicate the selected course.

15 With this construction, when one of the plurality of the



courses is selected by the game simulation machine , the indicator indicates the race course on which the plurality of moving objects compete in the certain game. Thus it would be easier for the player to know by which course the moving objects  
5 compete the game and it in turn allow the player to consider which one of the moving objects suit for the particular race course when he or she predicts a winner. Accordingly it could provide more realistic feeling to the player in participating the game and it increases fun for each game he or she plays.

10 In accordance with another aspect of the invention, the course indicator may be a plurality of guide lamps which are mounted along the lengthwise direction of the plurality of courses and the controller has a guide lamp flasher for illuminating the guide lamps corresponding to the race course.

15 With this construction, the selected race course can be recognized by the player with an illumination of the guide lamps which are provided along the lengthwise direction of the selected race course. Thus it provides a visual impact on the player participating the game and it makes game more visually  
20 enjoyable.

In another aspect of the invention, the controller may be set such that it sequentially illuminates the guide lamps in the order from one of the guide lamps closest to a starting point of the selected course first to the one of the guide lamps closest  
25 to the goal of the course last at a specified time interval.

With this construction, the controller illuminates the guide lamp closest to the starting point of the selected course and sequentially illuminates the one in the order of closeness towards the starting point of the course at the specified time  
 5 interval when the particular course is selected by the game simulation machine. Thus this would allow player to see, at once, into which direction the moving objects proceed at the time of betting so that this information of running direction can be taken into consideration for predicting the winner. In  
 10 addition, since the guide lamps are sequentially illuminating at the specified time interval, it would create a beautiful scenery on the game truck which would attract many players.

In still another aspect of this invention, the course indicator may have a plurality of guide lamp arrays which are  
 15 mounted along a lengthwise direction of the plurality of courses and each guide lamp arrays includes a plurality of guide lamps and the controller is set such that it flashes the guide lamps corresponding to the selected race course by the player in sequence at a specified time interval in a moving direction of  
 20 the moving objects.

With this construction, there exists the plurality of arrays consisting of guide lamps are provided along the lengthwise direction of the course; therefore, it would be easier for the player to know a whole size of the selected course  
 25 in a short period of the time since the guide lamps as many as



a number of the arrays emit light at the same time. Thus increasing the number of guide lamp arrays along the selected course would allow the player to perceive the size of the course easier than in case of no arrays such that the plurality of guide  
5 lamps are arranged all the way along the course at a specific pitch as it takes more time in this construction to complete the illumination of the whole guide lamps.

In still another aspect of this invention, the plurality of guide lamps are mounted on both sides of the plurality of  
10 courses along the lengthwise direction of the plurality of courses.

With this construction, since both sides of the selected course are provided with a plurality of guide lamps so that it allows more accurate perception of the feature of the selected  
15 course. It in turn enhances recognition of the size of the selected course.

In yet another aspect of this invention, the controller flashes the guide lamps in the respective arrays in a sequence order that the lamps closest to the starting line in the  
20 respective array illuminating first and the lamps closest to the goal of the selected race course in the respective arrays illuminating last at the specified time interval and this illumination sequence is repeated while the game is operated.

With this construction, the guide lamps in the arrays  
25 sequentially flush light as long as the game is played, thus

it appears as if the light emitted by the guide lamps produced an illumination loop encompassing the selected course rotates in the running direction of the moving objects. It gives a visual impact to the people nearby the game machine and it in 5 turn attracts more people in participating the game.

In yet another aspect of this invention the controller having a time control circuit for controlling the specified time interval between the illumination timing of the plurality of guide lamps.

10 With this construction, the time interval between the illumination of the plurality of guide lamps can be set by the time control circuit. There should exist an adequate range of frequency of the illumination which would please most of the players but outside of the range some may feel unpleasant. As 15 a result, being able to control this time interval is beneficial for attracting the players.

In the preferred embodiment of this invention, the moving objects can be made in the shape resembling the race horse and the certain game is a horse-racing game.

20 In another aspect of the invention, the plurality of courses includes a first course having an overlap portion which is shared with other courses and a non-overlap portion which is exclusively used for the first course, and the course indicator includes a plurality of the lamps provided along the 25 plurality of courses and the controller commands the course

indicator to illuminate the lamps along the overlap portion and the non-overlap portion of the first course when the first course is selected.

With this construction, since the plurality of courses are  
5 arranged such that portion of the one of the courses, namely a first course, is shared with some other course and the rest of the first course is exclusively used for the first course. Since the selected course is not independent from the other courses, it would be difficult for the player to see exactly  
10 where it starts and where it ends. When such course is selected, a plurality of lamps along the overlap portion and the non-overlap portion of the selected course are illuminated so that it would be easier for the player to see which course is selected by the game machine.

15 Having now summarized the invention, other objects, features and advantages thereof will become more apparent from the following detailed description and the accompanying drawings.

#### BRIEF DESCRIPTION OF THE DRAWINGS

20 FIG. 1 is a perspective view of a competitive game simulation machine according to an embodiment of the invention;

FIG. 2 is a plan view illustrating one form of a simulated playing field provided on the top surface of a main body of the competitive game simulation machine according to the

embodiment;

FIG. 3 is a fragmentary enlarged view particularly illustrating a paddock area;

FIG. 4 is a diagram generally illustrating a mechanism for  
5 moving simulated horses within the simulated field;

FIG. 5 is a fragmentary side view partially in section illustrating the horse moving mechanism of FIG. 4; and

FIGS. 6 and 7 are front and right side views showing an external construction of a guiding vehicle used in this  
10 embodiment, respectively;

Fig. 8 is a block construction diagram of the guiding vehicle when viewed from above;

FIG. 9 is a block diagram illustrating a circuit configuration for controlling a racecourse guide lamp flashing  
15 sequence.

**DETAILED DESCRIPTION OF THE PREFERRED EMBODIMENT OF THE INVENTION**

FIG. 1 is a perspective view of a competitive game simulation machine 1 according to an embodiment of the invention,  
20 in which the competitive game simulation machine 1 includes a plurality of moving objects resembling racehorses. As shown in FIG. 1, the competitive game simulation machine 1 comprises a table-like main body 11, a plurality of playing consoles 2 arranged around the main body 11 and a control unit 3 provided

at a lower internal position between a particular pair of playing consoles 2. The control unit 3 controls the operation of the whole competitive game simulation machine 1. The main body 11 has on its top surface a game board representing a playing field 4 which includes a track (playing area) 5 and a paddock (auxiliary area) 6.

At four corners of the main body 11 of the competitive game simulation machine 1, there are provided corner consoles 12, each having a fanlike shape in plan view. As the main body 11 is surrounded by the four corner consoles 12 and a specific number of playing consoles 2, the competitive game simulation machine 1 enables a plurality of players positioned around the main body 11 to participate together in a game. This construction provides the competitive game simulation machine 1 with a good external appearance as well.

Each of the playing consoles 2 has a slanted top panel of which inclination is increased at a rear portion (as viewed from a player). A horse entry indicator 21 including a cathode ray tube (hereinafter referred to as CRT) is provided at the left of the slanted top panel while a token slot 22 and the token dispensing tray 22a are provided at the right thereof. In addition, there is provided a horse data indicator 23 including a CRT at an uppermost part of the slanted top panel for displaying information on simulated horses H entered for a race. The participating players utilize the information presented on the

horse data indicators 23 as a reference for determining their bets.

The screen of each horse entry indicator 21 is covered with a transparent touch panel. As a player inserts a desired number 5 of tokens in the token slot 22 and touches an appropriate portion of the touch panel at his or her playing console 2 to specify a horse number which is displayed on the screen of horse entry indicator 21. For instance, with reference to Figs. 4 and 5, information on the player's choice of a particular horse H is 10 entered into a controller 31 incorporated in the control unit 3. Each of the corner consoles 12 is provided with a speaker 13 at a topmost position for generating sound effects including various kinds of imitation sounds and simulated announcements.

In the middle of one long side of the competitive game simulation 15 machine 1, there is provided a CRT video screen 14 at a slightly raised position to enable all the participating players to see video images presented, which are typically scenes of actual horse racing prerecorded by a video camera in a public racetrack. The images shown on the video screen 14 serve to create a vivid 20 and realistic atmosphere.

When the players positioned at the individual playing consoles 2 insert desired numbers of tokens in the token slots 22 and enter their bets by touching desired horse numbers displayed on the respective horse entry indicators 21, for 25 instance, with reference to odds and other information

displayed on the horse data indicators 23, it is regarded that betting ticket purchasing operation has been completed. In this embodiment, the horse entry indicators 21 allow the players to choose win bets, forecast bets or other forms of betting 5 through menu-assisted operation. When all the players have finished the betting ticket purchasing operation, or when a preset betting ticket purchasing time has elapsed, the simulated horses H (see Figs. 4 and 5) are caused to start off and run along a specified course in the track 5 under the control 10 of the control unit 3. The players receive returns, or "payoffs," at the end of the race depending on the correctness of their betting. These payoffs are delivered to the players in the form of tokens through token dispensing trays 22a provided beneath the individual token slots 22, and the number of tokens 15 returned to each player is determined in accordance with the odds.

FIG. 2 is a plan view illustrating one form of the field 4 provided on the top surface of the main body 11 of the competitive game simulation machine 1 according to the 20 embodiment. Provided in the middle of the field 4 is a generally oval-shaped central separating zone 51 which extends in a longitudinal direction of the field 4 in plan view. The track 5 on which the simulated horses H are run is formed between the periphery of the central separating zone 51 and that of the top 25 surface of the main body 11 of the competitive game simulation

machine 1. The track 5 occupies most part of the field 4 and the paddock 6 is formed to the left of the track 5.

A right-hand curved portion of the track 5 has a larger width than its other portions and there is formed a  
 5 crescent-shaped separating zone 52 approximately in the middle of right-hand curved portion of the track 5. The separating zone 52 is shaped such that its outer, or right-hand, convex edge faces a right-hand curved edge of the track 5 to form part of a long-distance track 5b therebetween whereas an inner, or  
 10 left-hand, concave edge of the separating zone 52 faces a right-hand curved edge of the central separating zone 51 to form part of a short-distance track 5a therebetween. The above-described field 4 has all along its outer edges an upright bank  
 41, which separates the field 4 from other elements on the top  
 15 surface of the main body 11 of the competitive game simulation machine 1.

There is provided a partition 42 in the middle of a boundary  
 between the track 5 and paddock 6 and a pair of starting gates  
 7 (first starting gate 7a and second starting gate 7b) are  
 20 connected to both ends of the partition 42. There are provided another pair of starting gates 7 (third starting gate 7c and fourth starting gate 7d), extending across the track 5 from  
 appropriate points on straight edges of the central separating zone 51 at right angles thereto. A course actually used in a  
 25 race is determined depending on which starting gate 7 the



simulated horses H are started from and whether the race is run over the short-distance track 5a or long-distance track 5b.

Among the starting gates 7 mentioned above, the third starting gate 7c and fourth starting gate 7d are made  
 5 individually rotatable about upright poles 72 provided on the bank 41. The third starting gate 7c and fourth starting gate 7d are turned around the respective upright poles 72 and individually stored in recessed storage spaces when not in use to clear the track 5. In this embodiment, each of the starting  
 10 gates 7 has ten starting booths 71 into which the individual horses H are entered before the race is started. FIG. 2 depicts a situation where some horses H which have left the paddock 6 are proceeding toward the third starting gate 7c to make themselves ready to start from that gate.

15 A number of racecourse guide lamps 8 are arranged all along an inside wall of the bank 41, the periphery of the central separating zone 51 and the outer convex edge and inner concave edge of the separating zone 52, all facing the track 5. Those racecourse guide lamps 8 which are located along the course to  
 20 be currently used sequentially flash in a wavy form moving in one direction so that the players can easily recognize the course and running direction of the horses H.

The competitive game simulation machine 1 offers 12 kinds of optional racecourses as shown in Table 1. It is possible  
 25 to choose one of these racecourses depending on which starting

gate 7 is used, whether the race is run over the short-distance track 5a or long-distance track 5b, and whether the horses H run clockwise or counterclockwise. There is a choice between two finish lines individually provided at approximately the 5 midpoints of opposing straight sections of the track 5 to allow for either clockwise or counterclockwise running direction. No matter which starting gate 7 is selected, each horse H entered for the race is caused to run at least one complete round of the track 5 before finishing.

10 TABLE 1

Course No.	Starting gate				Track length		Direction	
	1st (7a)	2nd (7b)	3rd (7c)	4th (7d)	Short (5a)	Long (5b)	CW	CCW
1	-				-		-	
15 2	-				-		-	
3		-			-		-	
4		-			-		-	
5			-		-		-	
6			-		-		-	
20 7			-		-		-	
8			-		-		-	
9			-		-		-	
10			-		-		-	
11			-		-		-	
25 12			-		-		-	

In the present embodiment, the simulated horses H are divided into groups of the following six colors: white, black, red, blue, yellow and green. Further, races may be run by six, eight or ten simulated horses H and serial horse numbers are 30 assigned to individual horses H entered in each race. These serial horse numbers are predetermined by setting code numbers

on dual-inline package (hereinafter referred to as DIP) switches provided in guiding vehicles which carry the individual horses H, wherein each DIP switch has at least four switch segments. To allow for such variations in performing 5 simulated races, sixteen horses H enclosed by thick lines in Table 2 are made available in this embodiment.

TABLE 2

Horse color		Horse colors and numbers					
		White	Black	Red	Blue	Yellow	Green
Type of race	6-horse						
	race	1	2	3	4	5	6
	8-horse					5	7
	race	1	2	3	4	6	8
15	10-horse			3	5	7	9
	race	1	2	4	6	8	10

As shown in Table 2, horse No. 1 in white, horse No. 2 in black, horse No. 3 in red, horse No. 4 in blue, horse No. 5 in yellow and horse No. 6 in green are entered for a six-horse race; 20 horse No. 1 in white, horse No. 2 in black, horse No. 3 in red, horse No. 4 in blue, horse No. 5 in yellow, horse No. 6 in yellow, horse No. 7 in green and horse No. 8 in green are entered for an eight-horse race; and horse No. 1 in white, horse No. 2 in black, horse No. 3 in red, horse No. 4 in red, horse No. 5 in 25 blue, horse No. 6 in blue, horse No. 7 in yellow, horse No. 8 in yellow, horse No. 9 in green and horse No. 10 in green are

entered for a ten-horse race. The simulated horses H entered are lined up and made ready to start from appropriate booths 71 in one of the starting gates 7 at the beginning of each race.

FIG. 3 is a fragmentary enlarged view particularly illustrating the paddock 6. As depicted in this enlarged view, the paddock 6 has at its middle position a waiting zone 61 which is divided into sixteen waiting spaces 610 and surrounded by a looping course (or paddock course) 62. There are provided a pair of passageways 63 (first passageway 63a and second 10 passageway 63b) for connecting the track 5 and paddock 6 at the outermost ends of the first starting gate 7a and second starting gate 7b.

The individual horses H are so controlled that they can move between the track 5 and paddock 6 through the passageways 15 63 and enter the waiting zone 61 through the looping course 62. There is made an arrangement to allow each horse H to enter the waiting zone 61 from its rear side (left-hand entrance side of the looping course 62 as illustrated in FIG. 3) and to leave the waiting zone 61 from its front side (right-hand exit side 20 of the looping course 62 as illustrated). This arrangement is intended to prevent collisions between horses H proceeding to one of the starting gates 7 for participating in a next race and those returning to the waiting zone 61 after running a preceding race.

25 An additional arrangement is made to cause the horses H

proceeding to the waiting zone 61 to sequentially enter those waiting spaces 610 which are empty and closest to the center of the waiting zone 61. This arrangement is meant to leave waiting spaces 610 close to both ends of the waiting zone 61  
 5 unoccupied as much as possible for permitting easy passage around the looping course 62 by the horses H returning to the waiting zone 61.

FIG. 4 is a diagram generally illustrating a mechanism for moving the simulated horses H within the field 4 and FIG. 5 is  
 10 a fragmentary side view partially in section illustrating the horse moving mechanism of FIG. 4. The field 4 is constructed with a synthetic resin board member. Underlying this board member parallel to each other is another board member, or a base plate 43, constructed with a transparent synthetic resin  
 15 material. A plurality of guiding vehicles 44 are located in a space between the top surface of the base plate 43 and the bottom surface of the board member of the field 4. On the bottom surface of the board member of the field 4, there is formed an array of square-shaped electrodes.

20 As shown in FIG. 5, each guiding vehicle 44 has on its top surface a plurality of electrode pins elastically protruding upward and arranged on the circumference of a circle of a specified radius, unillustrated right and left driving motors 44q1, 44q2 (see Fig.8) each of which is energized through  
 25 electrode pins 45, 45 (see Fig.6) which are slidably maintained

in contact with each one of the above-mentioned positive or negative electrodes, a pair of laterally aligned driving wheels 44a which are rotated by the driving motors, and idle wheels 44b which are provided to the front of the driving wheels 44a.

5 (It is to be noted that FIG. 5 shows only right-hand driving wheel 44a and idle wheel 44b since their left-hand counterparts are invisible in this side view.) Each guiding vehicle 44 thus constructed can be turned to the right or left depending on the difference in revolving speeds of the right and left driving

10 wheels 44a. When the right and left driving wheels 44a of a particular guiding vehicle 44 rotates at the same speed, that guiding vehicle 44 moves straight ahead and its traveling speed is controlled by the revolving speed of the driving wheels 44a.

Provided at an uppermost position of each guiding vehicle 44

15 is a generally X-shaped framework associated with an unillustrated springy element which exerts an uplifting force on the framework. Further provided on top of the X-shaped framework are rollers for regulating the height of the X-shaped framework and a magnet 44c which is kept scarcely out of contact

20 with the bottom surface of the board member of the field 4.

FIGS. 6 and 7 are front and right side views showing the external construction of the guiding vehicle 44. In these FIGURES, indicated at 44n is a hollow rectangular casing of the guiding vehicle 44. Casters 44b and drive wheels 44a are

25 rotatably mounted at a front bottom portion of the casing 44n

(right side in FIG. 6) and at a rear bottom portion of the casing 44n (left side in FIG. 6) with respect to a moving direction of the casing 44n. An unillustrated drive shaft of the drive wheels 44a are coupled with a motor unillustrated in FIGS. 6  
5 and 7, and the drive wheels 44a are driven by this motor.

Indicated at 44o is a circuitry board housed in the casing 44n. A variety of circuits such as a microcomputer to be described later are formed on the base plate 44o.

Indicated at 44h is an upper base located above the casing  
10 44n. The casing 44n and the upper base 44h are connected via an extensible pantograph mechanism 44i such that they move with respect to each other in the vertical direction. The pantograph mechanism 44i includes two each of link members 44j provided at the upper left and right ends of the casing 44n. The opposite  
15 ends of each link member 44j are connected with the upper part of the casing 44n and the lower part of the upper base 44h via pins 44k and 44l, respectively. The two link members 44j at the left and right sides are connected in their center via a pin 44m, and are biased by a spring 44p in such a direction that  
20 a distance between the casing 44n and the upper base 44h becomes larger.

A pair of casters 44f and a pair of rollers 44g are rotatably mounted at a front portion of the upper base 44h and at the left and right sides of the upper base 44h with respect to a moving  
25 direction of the upper base 44h, respectively. The upper ends of the casters 44f and the rollers 44g are at the same height. As shown in FIG. 2, when the guiding vehicle 44 is disposed

between the support plate (or base plate) 43 and the field 4, the upper ends of the casters 44f and the rollers 44g come into contact with the bottom surface of the field 4 and accordingly rotate as the guiding vehicle 44 runs. A permanent magnet 44c is disposed between the rollers 44g. The upper end of the permanent magnet 44c is set slightly lower than that of the rollers 44g. Thus, when the rollers 44g are in contact with the bottom surface of the field 4, the permanent magnet 44c is spaced apart from this bottom surface by a very small distance.

10 Indicated at 45 are current collecting electrode members (or an electrode pin) disposed at the front portion of the upper base 44h with respect to its moving direction.

FIG. 8 is a block construction diagram of the guiding vehicle when viewed from above.

15 The guiding vehicle 44 includes a pair of motors 44q1, 44q2 for independently driving the pair of drive wheels 44a1, 44a2 of resin or like material. In the description below, the drive wheels 44a1, 44a2 and the motors 44q1, 44q2 are indicated at 44a, 44q respectively unless specified.

20 In this embodiment, DC motors are used as the motors 46 so that the speed of the guiding vehicle 44 can be duty-controlled and the guiding vehicle 44 can run backward (by inversion of polarity of a supply current) if necessary.

Alternatively, pulse motors may be used so as to enable a speed  
25 control using a pulse frequency. Reduction gears are provided in a plurality of positions between a rotatable shaft of the motor 44q and that of the drive wheel 44a to ensure a specified



speed range.

Indicated at 44r is a one-chip microcomputer as a controller of the guiding vehicle 44. The microcomputer 44r analyzes a signal transmitted from a transmission LED 92 of a control unit 3 to generate a run control signal for the guiding vehicle 44, and causes front and rear LEDs 44d, 44d for emitting infrared rays. A ROM 44s is adapted to store an operation program of the microcomputer 44r. Indicated at 44u is a digital-to-analog (D/A) converter for converting a digital signal used for a speed control which is output from the microcomputer 44r into an analog signal used to drive the motors 44q.

The front and rear LEDs 44d, 44d are disposed at a front center portion and at a rear center portion of the casing 44n (not shown in FIG. 8) of the guiding vehicle 44 such that they are both directed right downward. A frequency band of the infrared rays emitted when the front and rear LEDs 44d, 44d are turned on corresponds with a transmission frequency band of an infrared filter provided on the front surface of a CCD camera 91 to be described later. Only the infrared rays having a frequency within the transmission frequency band can pass through the infrared filter. The infrared rays passed through the infrared filter are sensed by the CCD camera 91 disposed below the support plate (a base plate) 43. The LEDs 44d, 44d are fabricated such that the rays propagate over a wide angle. The rays can be sensed by the CCD camera 91 in any arbitrary position on the support plate 43.

Indicated at 44t is an infrared ray receiving unit which includes a photodiode or the like for receiving an optical pulse signal transmitted from the transmission LED 92. The unit 44t is so disposed as to face downward at the center bottom portion 5 of the casing 44n of the guiding vehicle 44. The unit 44t is, for example, exposed so as to receive the rays over a wide range. Indicated at 44v is a stabilized power supply circuit for generating voltages from the supply voltage supplied from the external power source such as a voltage of 5V necessary to 10 operate the microcomputer 44r and a voltage of 6V necessary to operate the motor.

Each of the simulated horses H comprises a carrier H1 which is supported by rotatably attached wheels and a horse model H2 which is mounted on the carrier H1 by a supporting bar. A magnet 15 H3 corresponding to the magnet 44c of each guiding vehicle 44 is attached to the bottom of the carrier H1 in such a way that the two magnets H3, 44c are positioned with their opposite magnetic poles facing each other. With this arrangement, each horse H can move around the field 4, following the movement of 20 its corresponding guiding vehicle 44 which travels on the base plate 43.

A pair of lamps 44d are mounted at appropriate front and rear locations on the bottom of each guiding vehicle 44. The front and rear lamps 44d sequentially flash in this order with 25 a specified small time interval to make it possible to detect the orientation of a particular guiding vehicle 44. Also

mounted at an appropriate location on the bottom of each guiding vehicle 44 is an infrared sensing device 44e which receives infrared control signals emitted from later-described light-emitting diodes (hereinafter referred to as LEDs) 92.

5 The control signals received by the infrared sensing device 44e are sent to an unillustrated control circuit incorporated in each guiding vehicle 44 and used for governing the revolving speeds of the right and left driving motors and their speed differential to control the moving speed and direction of each

10 guiding vehicle 44.

Movements of individual horses H participating in a race run on the track 5 and behaviors of the other horses H in the paddock 6 are controlled by the earlier-mentioned control unit 3 and a sensing system 9 which are provided inside the main body

15 of the competitive game simulation machine 1. The sensing system 9 includes specified numbers of cameras 91 employing charge-coupled devices (hereinafter referred to as CCD cameras) and the LEDs 92 located under the base plate 43.

The control unit 3 includes the controller 31 which

20 produces control signals upon receiving position signals from a below-described position detecting circuit 33 in accordance with a program stored in a read-only memory (hereinafter referred to as ROM) provided for controlling the progress of each game, an infrared LED driver 32 which transmits control

25 signals received from the controller 31 to the LEDs 92, the

position detecting circuit 33 which detects the positions and orientations of the individual horses H and inputs such information to the controller 31 based on sensing signals obtained from the CCD cameras 91 monitoring the front and rear  
5 lamps 44d of the guiding vehicles 44, and a flasher circuit 34 for supplying drive pulses to the racecourse guide lamps 8 which are constructed with LEDs, for example, at specified time intervals in accordance with control signals received from the controller 31. The lamps 44d flash in a particular sequence  
10 with small time delays from one guiding vehicle 44 to another. This time-sequential flashing pattern enables the control unit 3 to identify the individual guiding vehicles 44.

The controller 31 is programmed to periodically execute individual races determined by combinations of the course  
15 numbers shown in Table 1 and the types of race shown in Table 2, which are stored in the ROM, in a specific order on condition that the players have made their bets. If betting operation has not been done, a race is not run to prolong the operational life of each driving mechanism, for instance.

20 Described below is how each simulated race is executed. When a type of race has been determined with reference to the data shown in Tables 1 and 2, the controller 31 transmits control signals in accordance with the selected type of race to those horses H which have specified horse numbers via the LEDs 92.  
25 These control signals cause the relevant horses H to proceed

to a specified starting gate 7 and enter their specified booths 71.

The individual horses H are caused to run on the track 5 when a start signal is transmitted. The horses H located on 5 the track 5 at the end of a race move in accordance with control signals sequentially transmitted from the LEDs 92. More specifically, the horses H return to the paddock 6 through one of the passageways 63 and those horses H which will not participate in a next race enter empty waiting spaces 610 of 10 the waiting zone 61 by way of the looping course 62.

Although not depicted in FIGS. 4 and 5, the controller 31 can transmit control signals to the individual starting gates 7 as well. These control signals cause, for example, one of the third and fourth starting gates 7c, 7d to be set in its 15 operating position and the other stored in its storage space or both of them stored in their storage spaces depending on the course number selected from Table 1.

Distribution functions which define average running speeds and sprinting abilities of individual horses H 20 participating in a race are entered into the controller 31. The controller 31 calculates actual speeds and sprinting forces of the horses H during the race based on random numbers generated at specific time intervals from the distribution functions, and the horses H are caused to run in accordance with the calculation 25 results. Also entered into the controller 31 is information

on each simulated horse's running style, which determines whether a particular horse H is of a type which attempts to take the lead in an early stage of a race or of a type which puts on a finishing spurt, for example. This information is also  
5 reflected in the progress of each race.

Described next is how the controller 31 controls movements of the individual horses H in the paddock 6. The horses H which have finished the race are caused to line up in their finishing order and proceed to the paddock 6. As the horses H  
10 participating in a next race are already determined at this point, the horses H returning to the paddock 6 go through a passageway 63 which is on the opposite side of the starting gate 7 to be used in the next race. Upon returning to the paddock 6, horses H which will participate in the next race turn to the front side  
15 of the waiting zone 61 whereas horses H which will not run the next race proceed to the rear side of the waiting zone 61 and sequentially enter those waiting spaces 610 which are empty and closest to the center of the waiting zone 61.

Among the horses H participating in the next race, those  
20 which are positioned in the waiting zone 61 proceed in sequence toward the passageway 63 on the side of the next starting gate 7 specified through the front side of the looping course 62 at first, and those which ran the preceding race proceed to the specified starting gate 7 through the looping course 62 and the  
25 opposite passageway 63 next.

Behaviors of the individual horses H in the paddock 6 is determined with reference to an average value of the aforementioned distribution functions. Specifically, horses H having distribution functions with high average values actively move around the paddock 6 while those having distribution functions with low average values show slow movements. Alternatively, the individual horses H are so controlled that they exhibit behaviors suggestive of their characteristics as data on such characteristics is referred to at random. The players can make their betting decisions with reference to pre-race behaviors of the individual horses H. This arrangement helps produce realistic feelings.

FIG. 9 is a block diagram illustrating a circuit configuration for controlling the flashing sequence of the racecourse guide lamps 8 (also referred to as a course indicator). Depicted as an example in this Figure are the racecourse guide lamps 8 provided along the bank 41 of the long-distance track 5b. These racecourse guide lamps 8 are arranged in a series of guide lamp arrays, each array including a first guide lamp 8a, a second guide lamp 8b, a third guide lamp 8c and a fourth guide lamp 8d which are positioned side by side in a horizontal plane at equal intervals. Intervals between the first and fourth guide lamps 8a, 8d of adjacent guide lamp arrays are also made equal to the intervals between the guide lamps 8a-8d within each array. As shown in FIG. 9, there are  $i$  ("i" is an integer

larger than 3) guide lamp arrays, that is, a first guide lamp array 81, a second guide lamp array 82, . . . . ., and an ith guide lamp array 8i mounted in series on the inside wall of the bank 41. The players can recognize the currently selected course 5 and horse-running direction as the first to fourth guide lamps 8a-8d of each guide lamp array (81, 82, . . . . ., 8i) flash in sequence at the specified time intervals in the horse-running direction on the current course.

The flasher circuit 34 comprises a pulse generator 34a 10 which outputs a clock signal and a reference pulse signal obtained by dividing the frequency of the clock signal by four, a delay circuit 34b including a 4-bit shift register, and a switch 34c connected between the pulse generator 34a and delay circuit 34b. The switch 34c is provided for switching between 15 alternative input terminals of the delay circuit 34b for reference pulses in accordance with a control signal fed from the controller 31. The delay circuit 34b outputs pulse currents to the individual racecourse guide lamps 8 with sequential time delays in normal or reverse order depending on which input 20 terminal is selected by the switch 34c.

More particularly, if the switch 34c is set so that the reference pulse signal fed from the pulse generator 34a is supplied to the delay circuit 34b through its left-hand input terminal (as illustrated in FIG. 6), reference pulses are 25 cyclically outputted to the first guide lamp 8a, second guide



lamp 8b, third guide lamp 8c and fourth guide lamp 8d of each guide lamp array (81, 82, . . . ., 8i) in this order at clock pulse repetition intervals. As the racecourse guide lamps 8 flash in synchronism with the reference pulses, flashes of light  
 5 cyclically shift from the first guide lamp 8a to the fourth guide lamp 8d on each guide lamp array (81, 82, . . . ., 8i). This enables the players to recognize that the horse-running direction on the currently selected course is from the first to fourth guide lamps 8a-8d.

10 On the contrary, if the switch 34c is set so that the reference pulse signal fed from the pulse generator 34a is supplied to the delay circuit 34b through its right-hand input terminal (as illustrated in FIG. 6), reference pulses are supplied to the fourth guide lamp 8d, third guide lamp 8c, second  
 15 guide lamp 8b and first guide lamp 8a of each guide lamp array (81, 82, . . . ., 8i) in this order at the clock pulse repetition intervals. In this case, flashes of light cyclically shift from the fourth guide lamp 8d to the first guide lamp 8a on each guide lamp array (81, 82, . . . ., 8i) and the players can recognize that  
 20 the horse-running direction on the currently selected course is from the fourth to first guide lamps 8d-8a.

Although the pulse generator 34a is set to output reference pulses at a repetition interval of 0.4 second and clock pulses at a repetition interval of 0.1 second in this embodiment, the  
 25 invention is not limited thereto. What is required when each

guide lamp array has  $n$  (" $n$ " is an integer larger than 2) racecourse guide lamps 8 (i.e., first to  $n$ th racecourse guide lamps) is that the interval between successive reference pulses should be made  $n$  times longer than the interval between the clock pulses. The clock pulse interval is not necessarily limited to 0.1 second either. It may be set to any appropriate value in accordance with the type of race or traveling speeds of individual moving objects. In another alternative, the clock pulse interval may be made variable between the first and second halves of a race or in accordance with degrees of excitement in a sequence of racing scenes.

Described above is how the flashing sequence of the racecourse guide lamps 8 provided along the bank 41 of the long-distance track 5b is controlled. Since the racecourse guide lamps 8 provided along the periphery of the central separating zone 51 and the edges of the separating zone 52 are also controlled in a similar flashing sequence, the players can easily recognize the currently selected course and horse-running direction.

The paddock 6 is provided with the waiting zone 61 for accommodating non-participating horses H. This arrangement make it possible to run a 6-horse race, an 8-horse race, and so on among properly selected horses without leaving non-participating horses H on the track 5 so that each race on the track 5 can be run in a more realistic manner compared to the

conventional competitive game simulation machines.

Although the invention has thus far been described with reference to its preferred embodiment which employs the horses H as moving objects, other kinds of moving objects may be used  
5 instead of the horses H. To cite a few examples, the moving objects may be formed in the shape of racing cars, racing bicycles or even players of soccer or other ball games.

Although the competitive game simulation machine 1 of the foregoing embodiment is provided with the choice of two  
10 racecourses, i.e., the short-distance track 5a and long-distance track 5b, the invention is not limited to this configuration. There may be provided more than two racecourses on the track 5 by properly arranging separating zones and mounting the flashing racecourse guide lamps 8 on both sides  
15 of the individual racecourses.

Furthermore, it would also be possible to set a short straight course starting at the starting gate 7a (see Fig.2) and finishing at the finish line 7c (see Fig.2). Or another race course starting at the line 7c (see Fig.2) and ending at  
20 the line 7d (see Fig.2) may be set as one of the selectable courses to increase a variety of the selections.

It is also possible to modify the course indicator to be a non light emitting object such as a plurality of members mounted along the lengthwise direction of the plurality of  
25 courses and which are operated by the controller to move up and

down to indicate the selected course by the operator. Various forms of the course indicator could be used without departing the spirit of this invention.

Although the present invention has been fully described  
5 by way of example with reference to the accompanying drawings,  
it is to be understood that various changes and modifications  
will be apparent to those skilled in the art without departing  
from the spirit and scope of the present invention. Accordingly,  
the invention should not be limited by the foregoing description  
10 but rather should be defined only by the following claims.

5  
5  
5  
5  
5  
5  
5  
5

~~WHAT IS CLAIMED IS:~~ The claims defining the invention are as follows:

1. A course guide apparatus used for a competitive game machine having a plurality of race courses, and a plurality of moving objects competing a certain game, the course guide apparatus comprising:

a course indicator for indicating the course on which the plurality of moving objects compete in the certain game and the course indicator is mounted along a lengthwise direction of the plurality of race courses;

a controller for controlling the course indicator so as to indicate the course.

2. A course guide apparatus according to claim 1, wherein the course indicator is a plurality of guide lamps mounted along the lengthwise direction of the plurality of courses.

3. A course guide apparatus according to claim 2, wherein the controller having a guide lamp flasher for illuminating the guide lamps corresponding to the race course.

4. A course guide apparatus according to claim 2, wherein the controller is set such that it illuminates the guide lamps in the sequential order from one of the guide lamps closest to a starting point of the selected course first to the one of the

guide lamps closest to the goal of the selected course last at a specified time interval.

5. A course guide apparatus according to claim 1, wherein the course indicator having a plurality of guide lamp arrays which are mounted along a lengthwise direction of the plurality of courses and each guide lamp arrays includes a plurality of guide lamps and the controller is set such that it flashes the guide lamps corresponding to the selected race course in sequence at a specified time interval in a moving direction of the moving objects.

6. A course guide apparatus according to claim 2, wherein the plurality of guide lamps are mounted on both sides along the plurality of courses.

7. A course guide apparatus according to claim 5, wherein the controller flashes the guide lamps in the respective guide lamp arrays in a sequence order that the lamps in the respective arrays closest to the starting line illuminating first and the lamps in the respective arrays closest to the goal of the selected race course illuminating last at the specified time interval and this illumination sequence in the respective arrays is repeated while the game is operated.

8. A course guide apparatus according to claim 7, wherein the controller having a time control circuit for controlling the specified time interval between the illumination timing of the plurality of guide lamps.

9. A course guide apparatus according to claim 8, wherein the moving objects are made in the shape resembling the race horse and the certain game is a horse-racing game.

10. A course guide apparatus according to claim 1, wherein the plurality of courses includes a first course having an overlap portion which is shared with other courses and a non-overlap portion which is exclusively used for the first course, and the course indicator includes a plurality of the lamps provided along the plurality of courses and the controller commands the course indicator to illuminate the lamps along the overlap portion and the non-overlap portion of the first course when the first course is selected.

11. Apparatus substantially as described herein with reference to the accompanying drawings.

**DATED this FIFTH day of AUGUST 1996**

**Konami Co., Ltd.**

**Patent Attorneys for the Applicant**

**SPRUSON & FERGUSON**







16 886 61039

FIG. 2

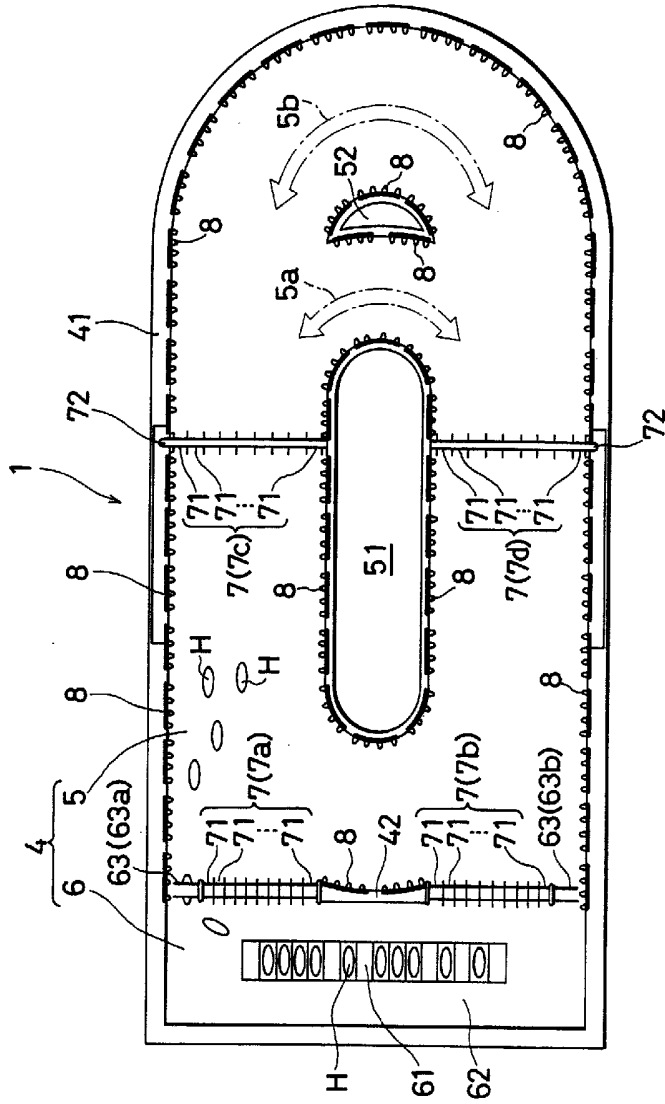
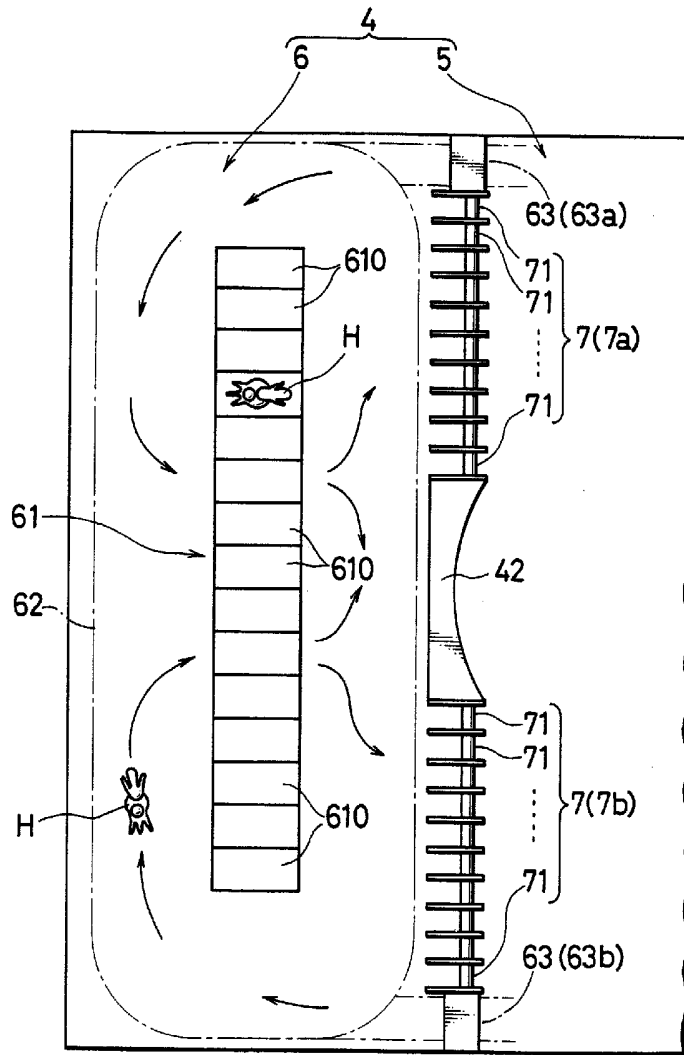

FIG. 3



16 986 6103

61939/96

FIG. 4

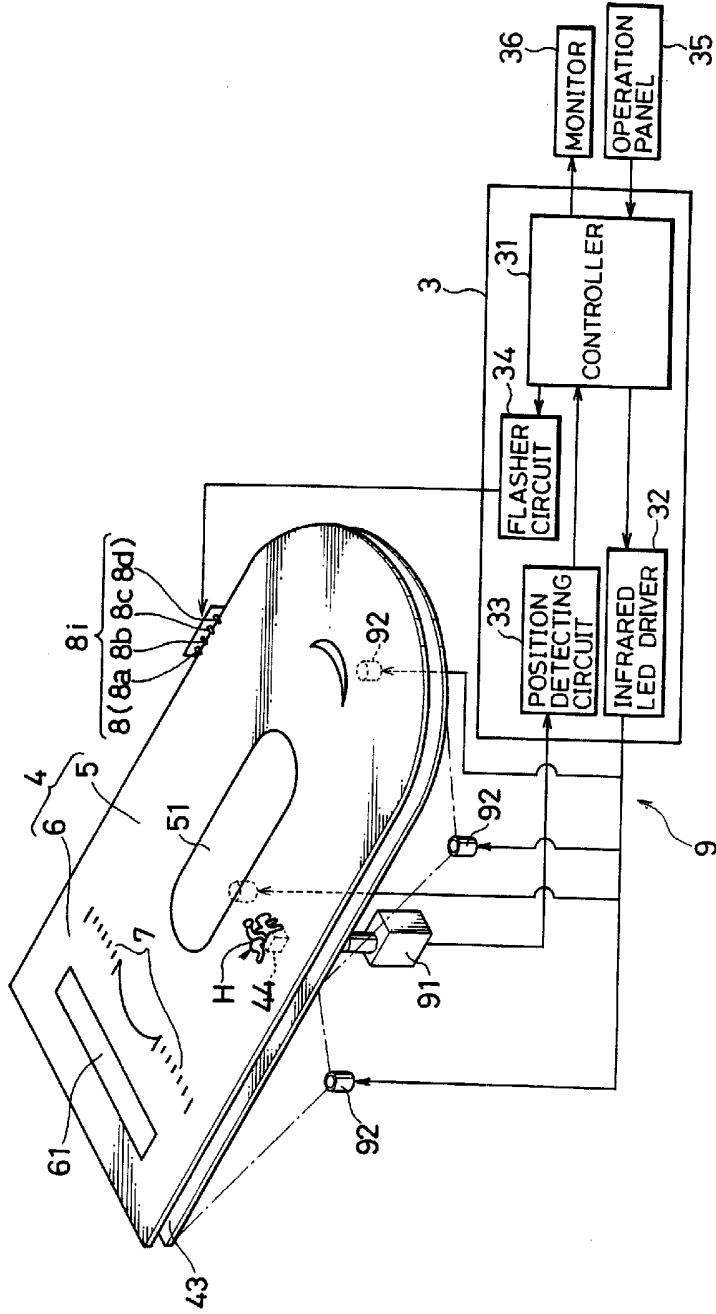

FIG. 5

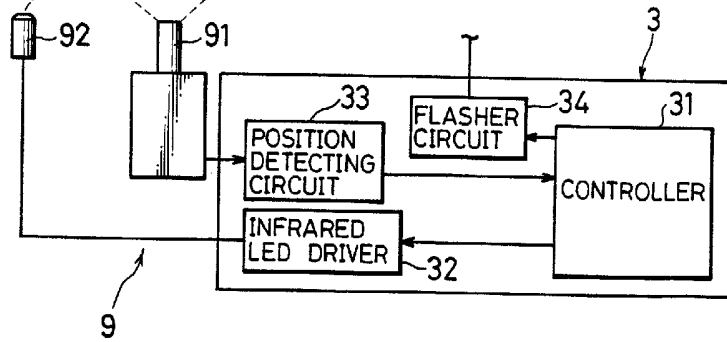
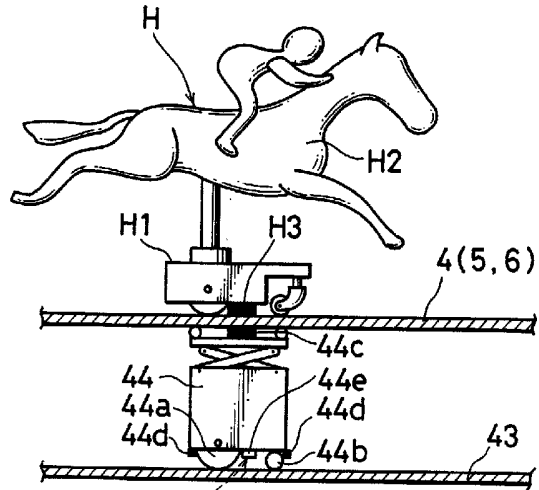

FIG. 6

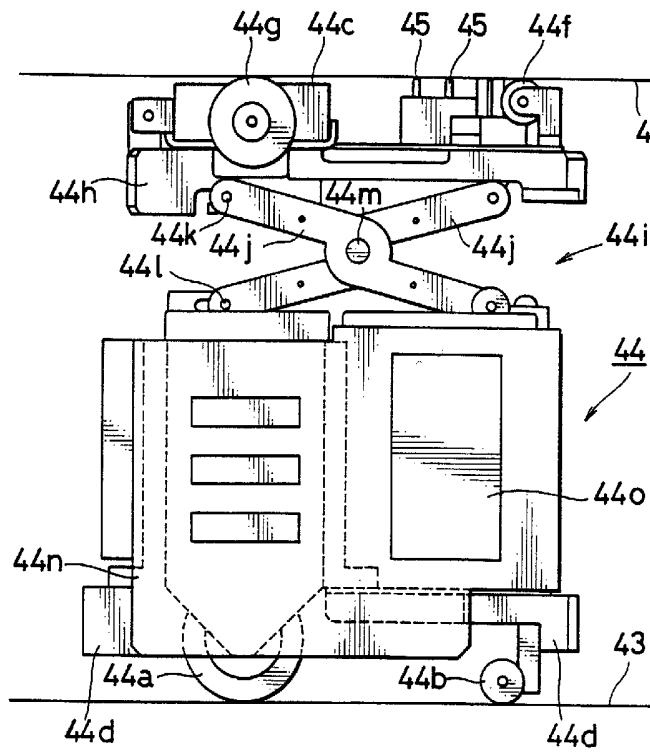
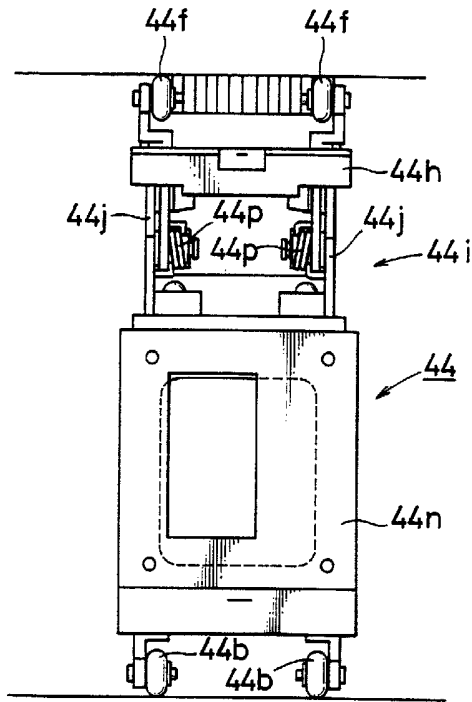
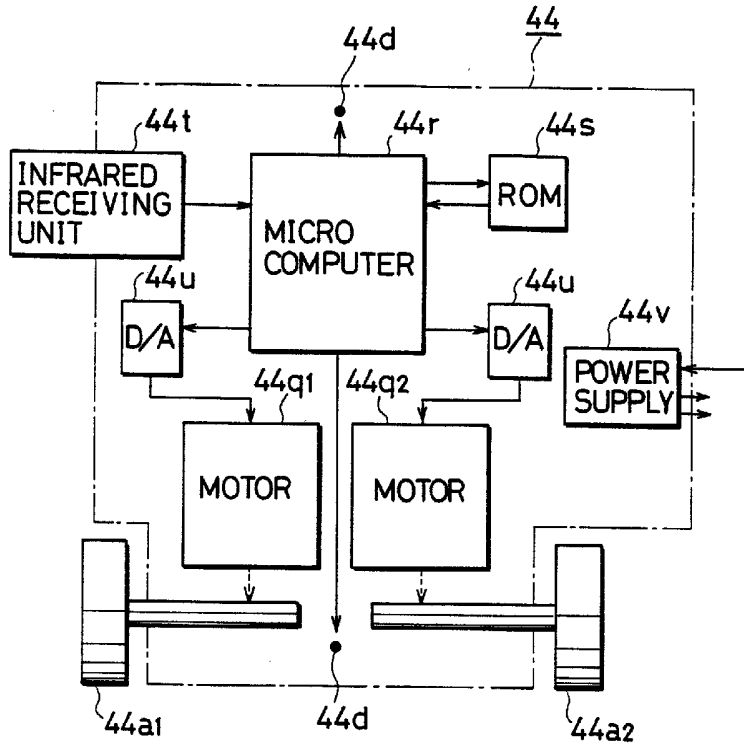

FIG. 7



5  
6  
7  
8

FIG. 8



15 035 6190

FIG. 9

