

(No Model.)

W. H. WITT.  
PLOW ATTACHMENT.

No. 267,630.

Patented Nov. 14, 1882.

Fig. 1.

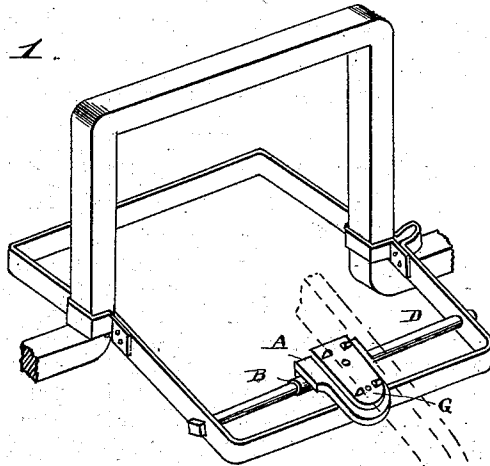

Fig. 2.

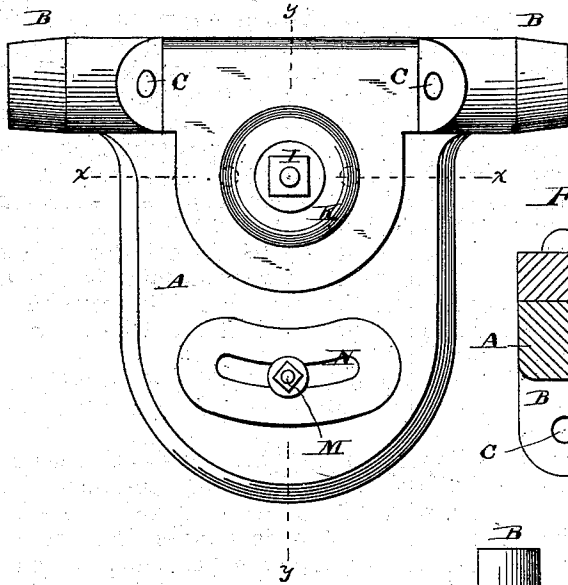

Fig. 3.

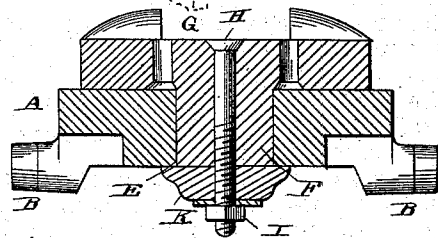

Fig. 4.

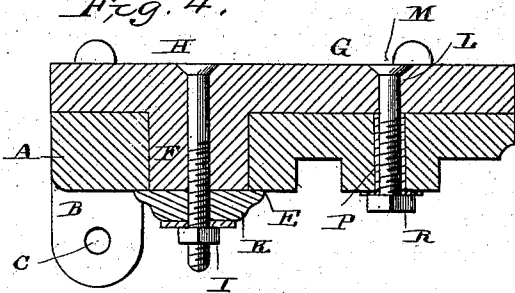
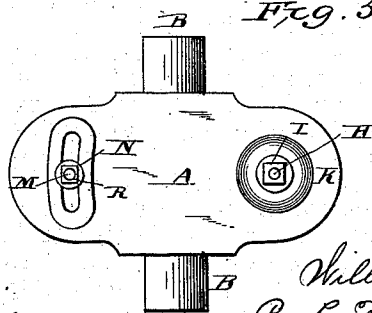

Fig. 5.



Witnesses,  
Edwin L. Jewell.  
J. J. McCarthy.

Inventor,  
William H. Witt,  
By C. M. Alexander  
Attorney.

# UNITED STATES PATENT OFFICE.

WILLIAM H. WITT, OF RICHLAND TOWNSHIP, FOUNTAIN COUNTY, INDIANA.

## PLOW ATTACHMENT.

SPECIFICATION forming part of Letters Patent No. 267,630, dated November 14, 1882.

Application filed July 12, 1882. (No model.)

To all whom it may concern:

Be it known that I, WILLIAM H. WITT, of Richland township, in the county of Fountain, and in the State of Indiana, have invented certain new and useful Improvements in Attachments to Plows; and I do hereby declare that the following is a full, clear, and exact description thereof, reference being had to the accompanying drawings, and to the letters of reference marked thereon, making a part of this specification.

This invention relates to certain improvements in sulky-plows, and it has for its objects to provide for the automatic adjustment of the plow-beam with respect to the frame of the sulky, either vertically or laterally, as more fully hereinafter specified.

Before proceeding to describe my invention, I desire to state that I am aware that devices have been made for a similar purpose, and that plates have been used for connecting the plow-beam with the sulky-frame, and that I do not broadly claim such a construction, but rely upon the means constructed as hereinafter pointed out.

Figure 1 represents a perspective view of a portion of the frame of a sulky-plow showing my invention. Fig. 2 represents a detached view of my improved device. Fig. 3 represents a sectional view taken on the line *x x* of Fig. 2. Fig. 4 represents a sectional view taken on the line *y y* of Fig. 1, and Fig. 5 represents a modification of my improvement.

The letter A indicates a metallic plate, which is provided with lateral trunnions B at each side at the front. These trunnions are bored longitudinally, as indicated by the letter C, so as to fit over the bar or rod D, attached to the frame of the sulky, as indicated in Fig. 1 of the drawings. These trunnions, it will be observed, lie in a horizontal plane considerably below that of the plate proper, the object of which is to allow of the free and unobstructed vertical play of the rear end of the plate, whereby it is made capable of adjusting itself to the irregular movements of the plow-beam. The difference of measurement between said planes is determined by the width of the "bail," or that portion of the frame to which the rod D

is fastened. The plate A is provided with a circular aperture, E, in which is adapted to fit the boss F of a plate, G, forming a strong and substantial pivotal connection between the two plates, suitable to the nature of the strain to which the parts will be naturally subjected. The said plates are held together by a screw-bolt, H, nut I, disk L', and washer K, so that they can move freely with respect to each other. The plate G is provided with an aperture, L, through which passes a screw-bolt, M, extending through a segmental slot, N, in the plate A, and provided with a loose sleeve, P, and a nut, R, the sleeve serving as a friction-roller to permit the parts to move freely upon each other, and the bolt as a means of limiting the lateral movement of the plow-beam.

In the modification shown in Fig. 5 of the drawings the trunnions are formed about midway between the ends of the plate A. The screw-bolts by which the plates are secured together have their heads flush with the upper surface of the plate G, the said heads setting in countersunk recesses in said plate, as indicated, and the said plate G is provided with lugs H, between which the plow-beam is secured.

Having thus described my invention, what I claim, and desire to secure by Letters Patent, is—

The combination, in a plow-beam attachment, of a lower plate, A, having apertures E, segmental slot N, a sleeve, P, and lateral trunnions B, which lie in a lower plane than the plate proper, and an upper plate, G, provided with a boss, F, and an aperture, L, the said slot, aperture L, and a bolt, M, permitting of lateral adjustment of the upper plate, whereby the course of the plow is direct and maintained, and the lower plane of the trunnions permitting of the vertical movement of the plow-beam, all substantially as shown and described.

In testimony whereof I affix my signature, in presence of two witnesses, this 25th day of May, 1882.

WILLIAM H. WITT.

Witnesses:

WILLIAM L. STEPHENS,  
RICHARD A. STEPHENS.