

(19)
(12)

(KR)
(A)

(51) 。 Int. Cl. ⁷
H01L 23/48

(11)
(43)

2001 - 0070094
2001 07 25

(21) 10 - 2000 - 0055730
(22) 2000 09 22

(30) 11 - 268472 1999 09 22 (JP)

(71) 가 가
가
5 7 1

(72) 5 7 1 가 가

(74)

:

(54)

, (12) (13) (11)
, (13) (11) (12) (13) (11)
(14) (12) (14) 1
, (13) 1 (12) .
, , .

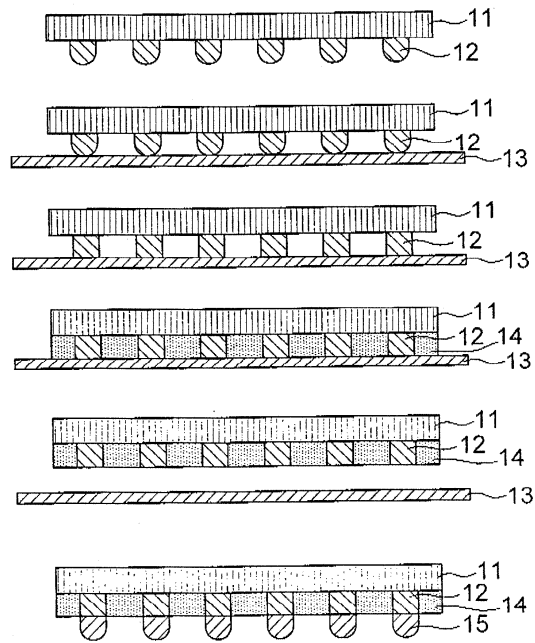

, , , ,

1 FCBGA

2a 2f 1

3a , 3

b 1 ,

4a 4f 2

5 (black copper) 가 ,

6a 6f 3

7a 7e 4

8 LSI ,

9a 9c 가 LSI ,

10a 10g 5

, ,

11a 11g 6

. ,

*

11 : LSI 12 :

13 : 14 :

15, 25 : 22 :

(" LSI ")
 . LSI
 (FCBGA)
 FCBGA 1 LSI (11),
 (12), (33) (24)
 가 LSI (11) LSI (11) (probe) (25)
 (34)가 (33) (24) (34)
 (12) (33) (14)가 LSI (11), (12) (33)
 , LSI (11) (24) , LSI (11) (24)
 가 (14) LSI (11), (12) (33)
 (25) (24)
 (stepper) (24) LSI (11) , LSI (24) , LSI
 (aligner) (24) 가 가
 , LSI (11) 가 (24)
 (bare) / , LSI
 , 가,

가

1 ;
(embed) ; 1

2 ;

1 2 ;

1

2a (Sn) (Pb) (12) LSI (11)
(Au) 가 (12)

(13) (12) , LSI (11) 2b (13)
(13) (13) LSI (11)
(impregnation)

2c 가 LSI (11) (13) 가 (12) (13)
가 1000 , LSI (11) (13) 100 150
10 50kg 가 (flux)가 (13) (12)

가 가 LSI (11) LSI (11) (13)
,가 (dig)가

2d (14)가 LSI (11), (12) (13) (gap)
, LSI (11) (12) (filler)
(epoxy - based paste)가 (14) (14)
150

2e (13) 2d (12) (14) 가 (13) 가
 2f (12) (15) (12)
 1 (12) (13) 가 (13)
 2e LSI (11)
 4) 가 (14) (12) (14) 3a (1) 가
 (12)가 1 (14)가 가 3b
 2
 4a (12) LSI (11) 1 (13)
 4b (12) LSI (11) (Cu) (Al)
 가 (13) (quasi) (12)
 (13) (12) (13a)
 (31) 5 (31) (13)
 (12)
 5
 4c LSI (11) (12) LSI (11)
 (13) LSI
 4d (14) LSI (11), (13) (12)
 1
 4e (14) 4d (13) (12)
 2 (ferric chloride) (etchant)가 4d (13)
 (13) (12) 가
 (cancave)
 4f (15) (12)
 (12)

2 (12) (14) (13),
(13)

1 2 (14),
2a 2f 4a 4f

()
,가 가 (heat - applying)
(25) 가 (crack)

3

, 6a LSI (11) 6b (13) (13) LSI (11)
(12) 가

(13), (12) 가

, 6c (13) LSI (12) LSI (11)
(13)

, 6d (14)가 LSI (11), (13) (12)
1

, 6e , 6d (13) (12) (14)
2 가 (13)

(13), (12)

, 6f (15) (14) (12)
(12)

2 3 , , 1 ,
(13) 4e LSI (11)
(14)가 가

1 3 (interposer, 24)(1)가
(25) LSI (11)

4

7a LSI (11) , (21)
 (13) , LSI (21) (
 13) 7b LSI .
 (13) LSI (13)

(21) LSI (11) (13) ,
 LSI (11)
 가 (13) LSI (11)

7c , (14)가 LSI (11), (13) (21)
 1

7d , 7c (13) (21) (14)
 2 가

7e , (15) (14) (21)
 (21)

(21)

(21) 7b LSI (11) 8 ,
 (21) (32) (32a) LSI (11) (2
 1)

9a , (21) LSI (11)
 (23) , 9b , (21)

(21) LSI (11) , 9c , (21)

(21) 4 , ,
 (21)

5

10a LSI (11) , (12) .
 LSI 10b (13)

(22) , , , ,

(13)

(22) , , (active method), (clad)
 가

, 10c , LSI (13) (22)
 , (12) LSI (11) (13) 가

, 10d , (14) LSI (11), (13) (12)
 . 1

, 10e , (13) (22) (14)
 . , 10d (13) (22) (22)
 . (13) 2

, 10f , (23)
 (22)

, 10g , (15) (22)

6

11a LSI (11) , , (12)
 LSI 11b (22) (13)

(22) , , (13) 가
 (13) (22) (13) (half - etching)

, 11c , LSI (13) (22)
 , LSI (11) (13) 가 (

12)

, 11d , (14) LSI (11), (13) (12)
 . 1

, 11e , (13) (14) (22)
 . , 11d (13) (22) (22)
 . (13) 2 가가

(22)

, 11f , (23)가
 (22)

, 11g , (15) (22)

LSI (11) 5 6 (

) (23)

(22)

4 6 , (14) 23) , LSI (11)
 1 3 , LSI
 가가

1 6 , LSI (11) (13) , (14)
, (13) 가 , ()
1 24) LSI (11) .

가 1 6 , LSI (11) (12)
(14) , LSI (11)
, (12) (12)
(scar) (probing) LSI
, LSI (11) (14)

1 6 , (14) (14)
가 (14) , (potti
ng) , (transfer - molding)

, LSI , LSI (11) LSI (13)
, (14) 7b ,
, (14) (dropwise) LSI (11) 가
, (14)

1 6 , (13) (1) (3) ,
(1) (13) (12) (14) (13)

(2) (13) ,

(3) (13) (planarity) 가 , (12) (14)

(3) , (24) 1
, (24)가 LSI (11) ,
(12) (14) 가 (13)

1 6 , (15)

(14) , (12) LSI (11) 1 6
가 (heat splitter)(
) (, 2a) LSI (11) .

(57)

1.

- (a) (12) (13) (11) ;
- (b) (13) (11) (12) 가 ;
- (c) (13) (11) (14) (12) ;
- (d) (14) 1 ;
- (e) (13) 1 (12) .

2.

1 , (b) (12) 가

3.

1 , (12) (11) .

4.

1 , (12) .

5.

1 , (12) , (1
3) (22) .

6.

5 , (22) (13)

7.

5 , (22) ,

8.

5 , (e) 1 (22) 2

9.

1 , (e) 1 (22) (25)

10.

1 , (13) (e) 1 (12)

11.

1 , (13)

12.

1 , (13) .

13.

(12) (11), (12),

(12)

14.

13 , (12)

15.

13 , 1 (12) 1

16.

13 , 1

17.

13 , (12)

18.

13 , (12)

19.

13 , (12) (13)
(22)

20.

13 , (22) 2

21.

13 , 1 (12)

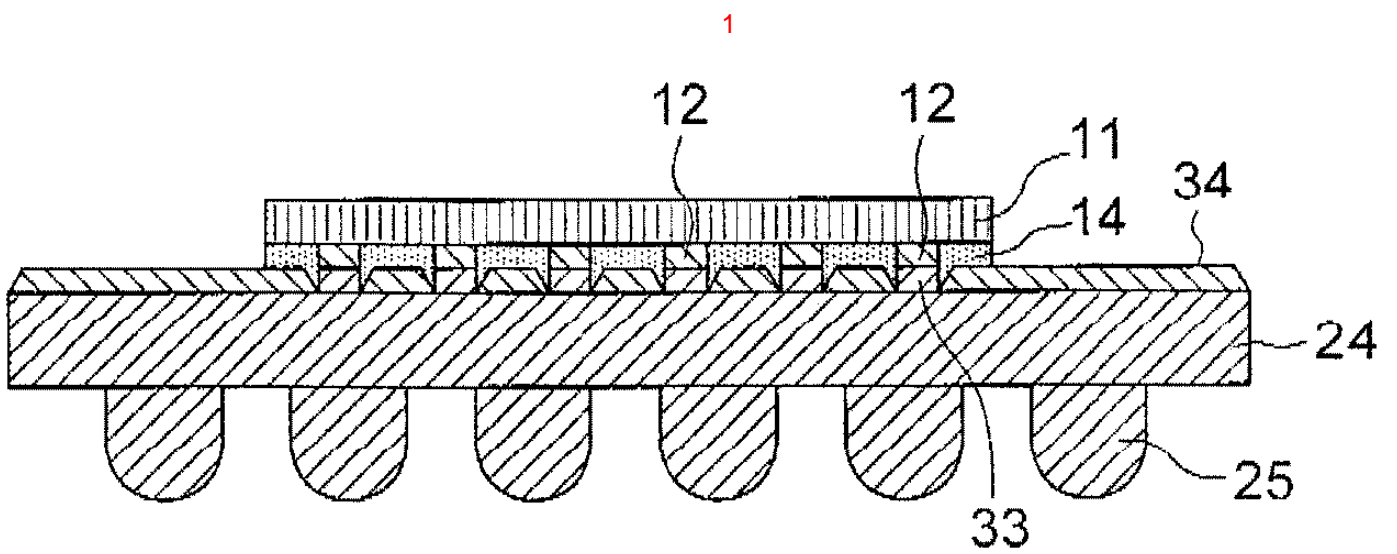

2a

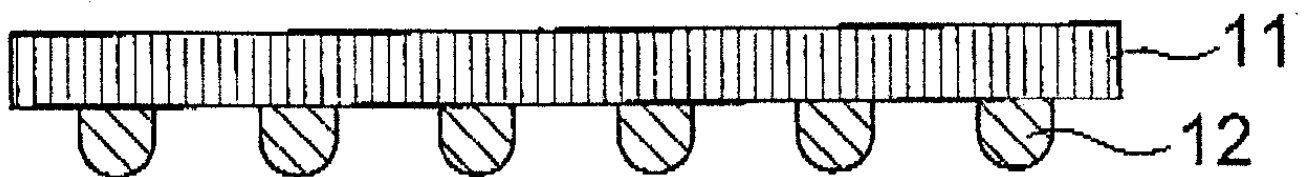

2b

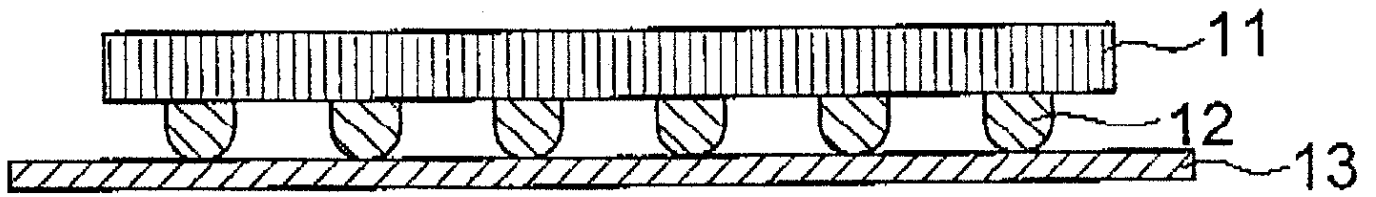

2c

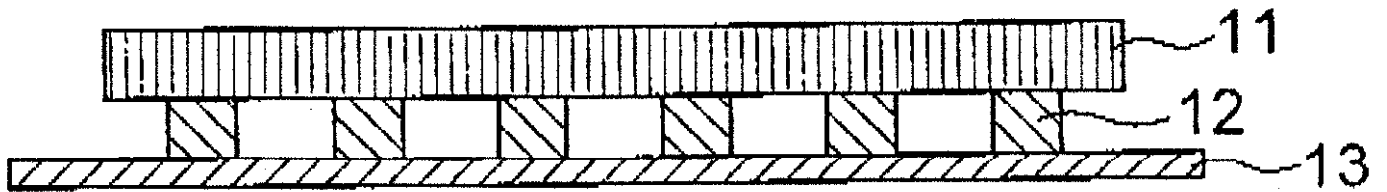

2d

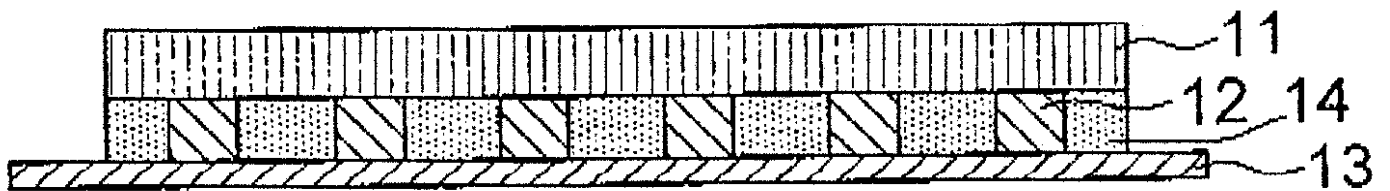

2e

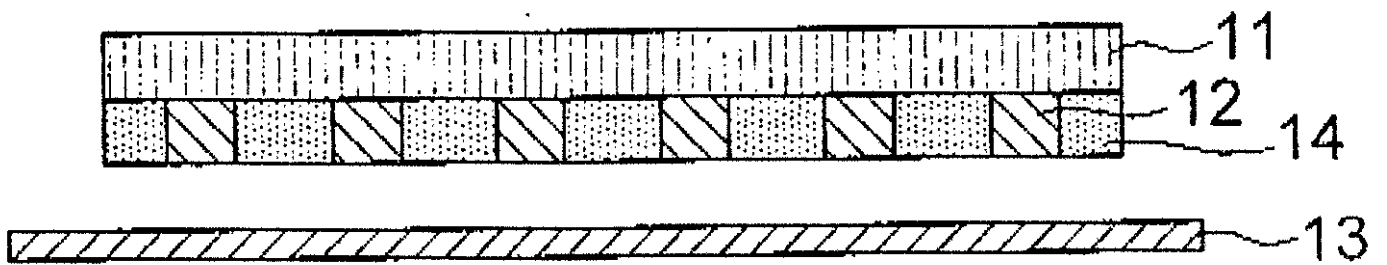

2f

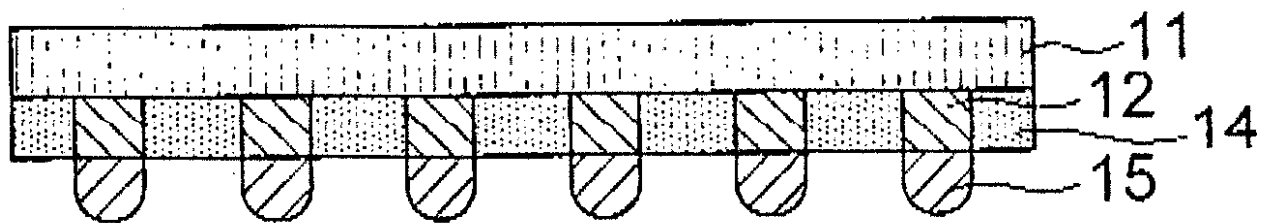

3a

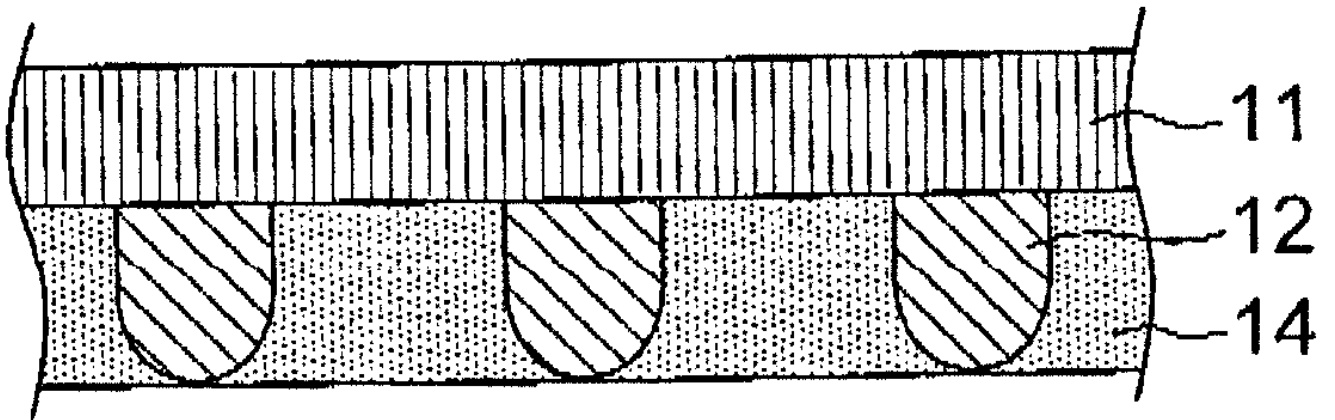

3b

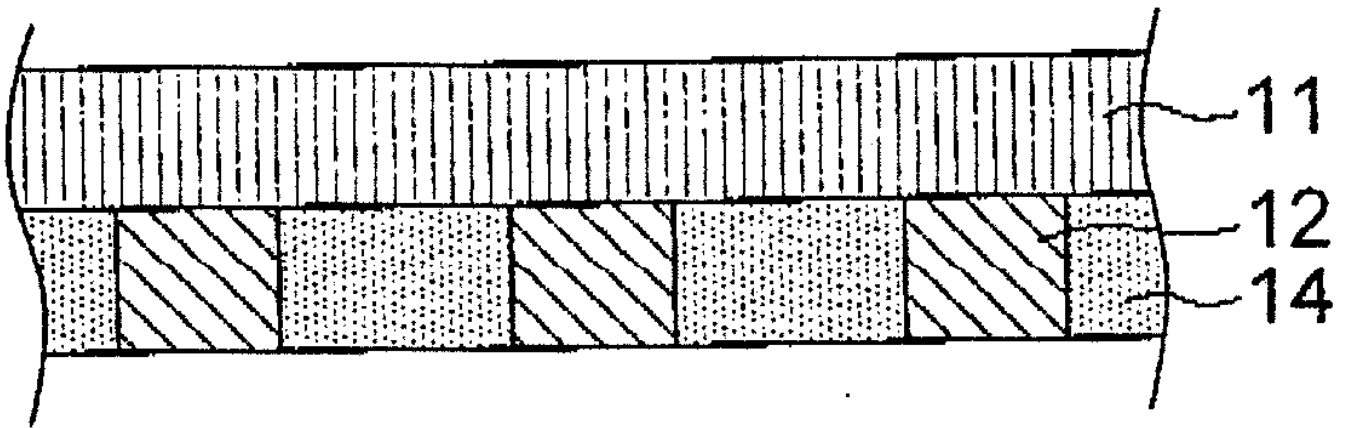

4a

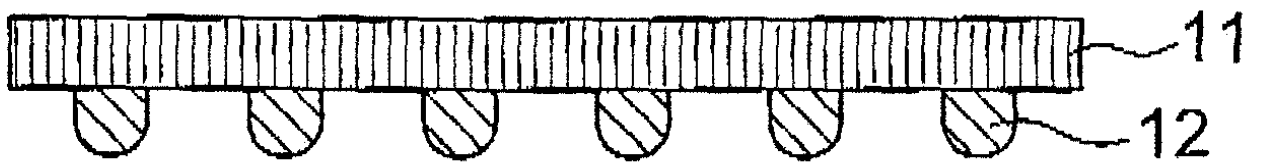

4b

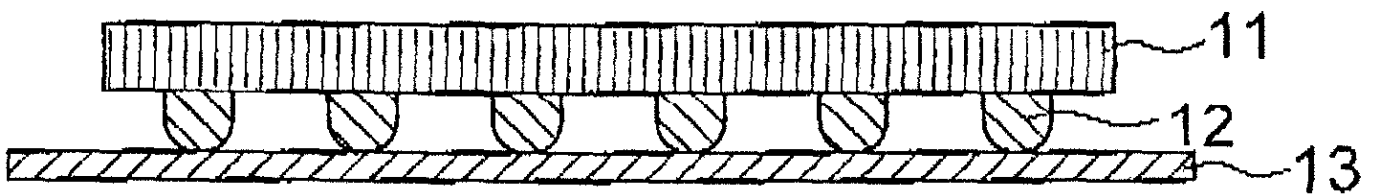

4c

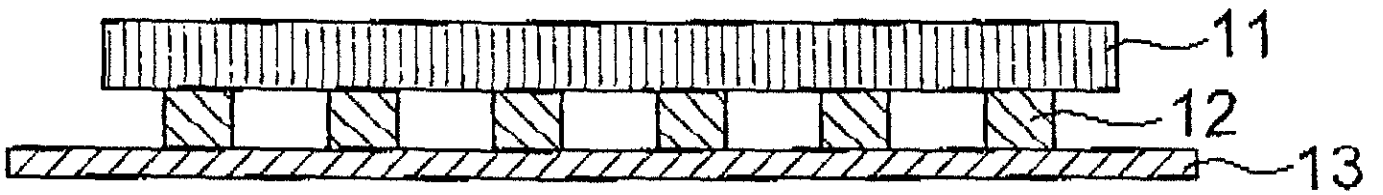

4d

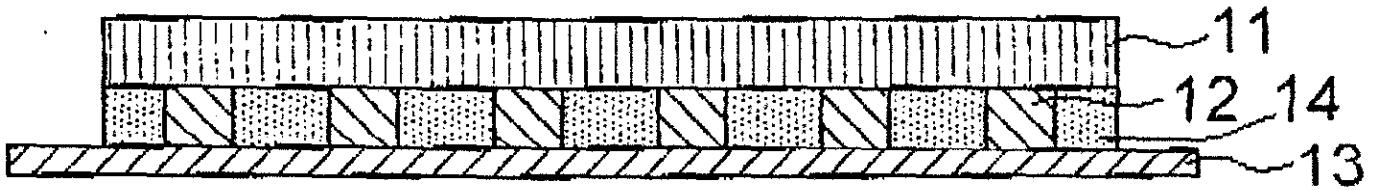

4e



4f

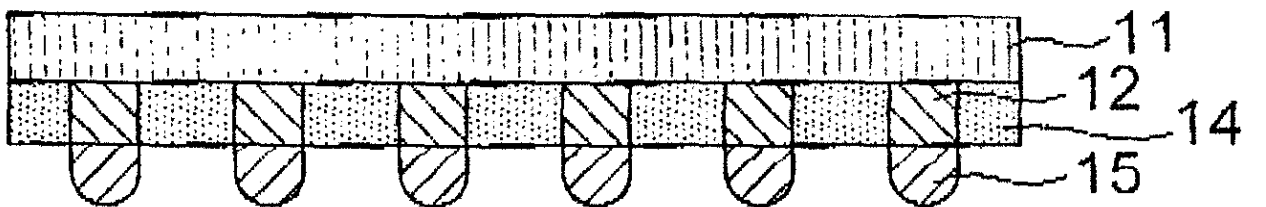

5

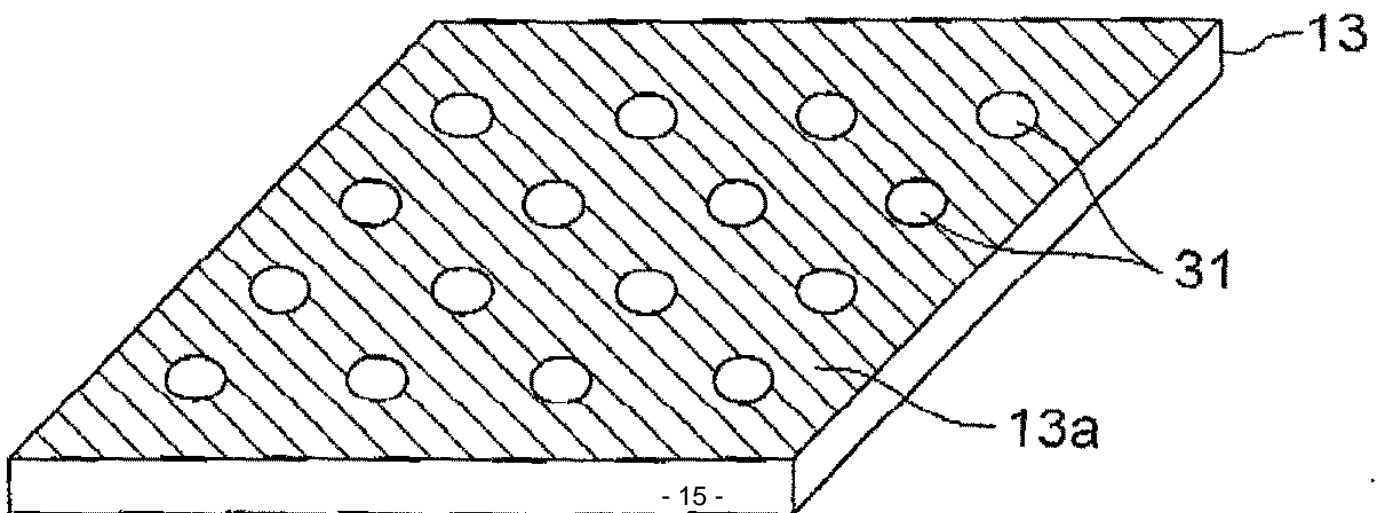

6a



6b

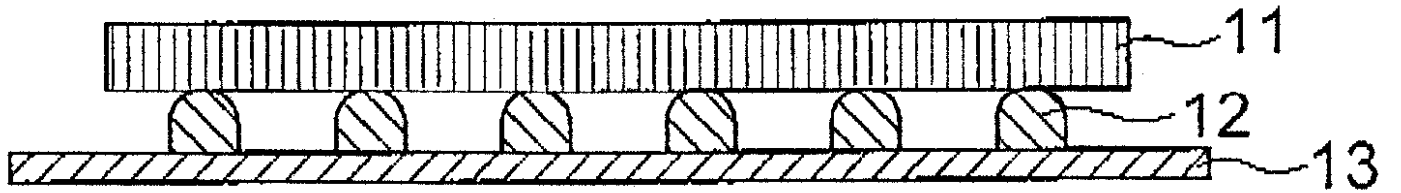

6c

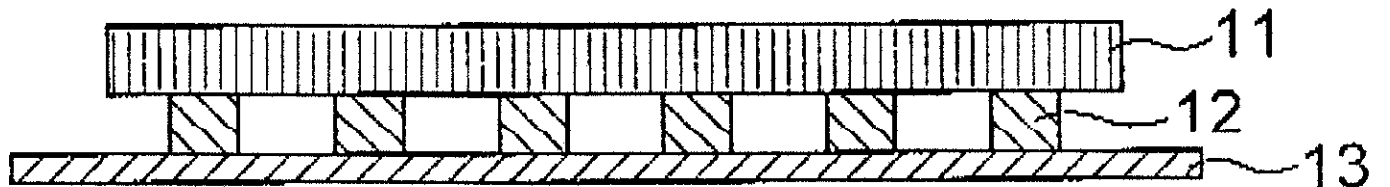

6d

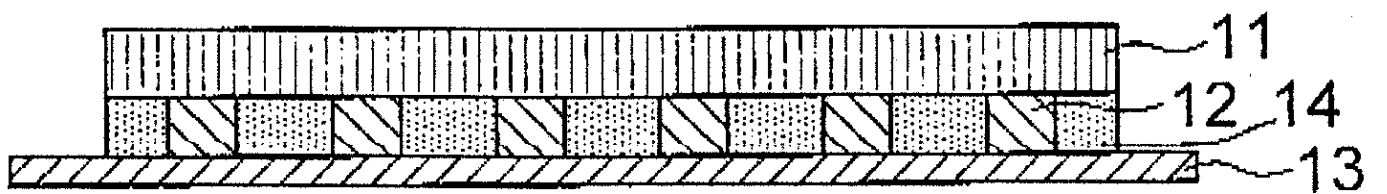

6e

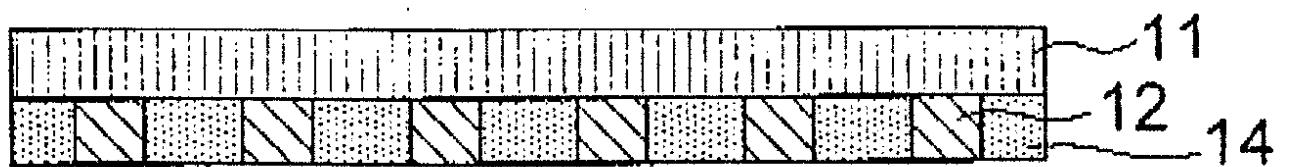

6f

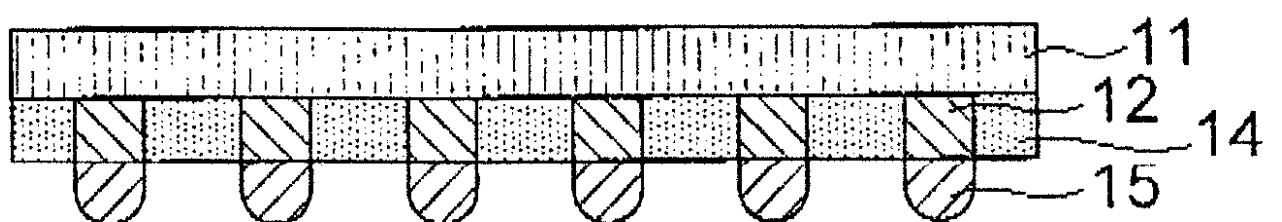

7b

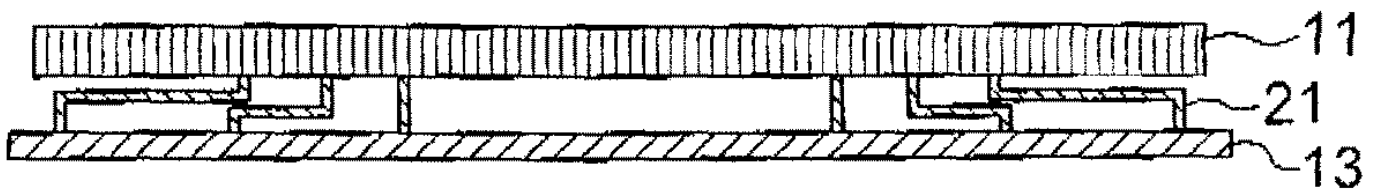

7c

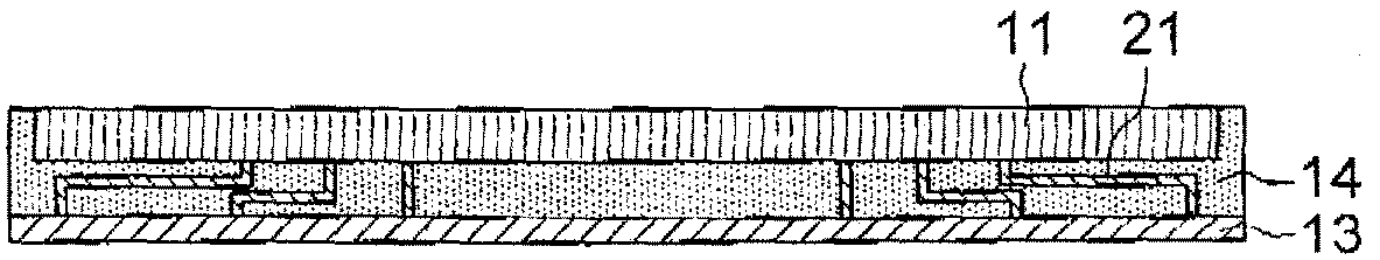

7d

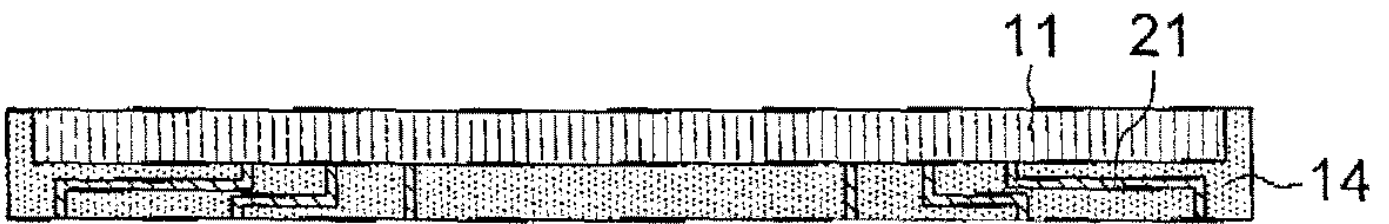

7e

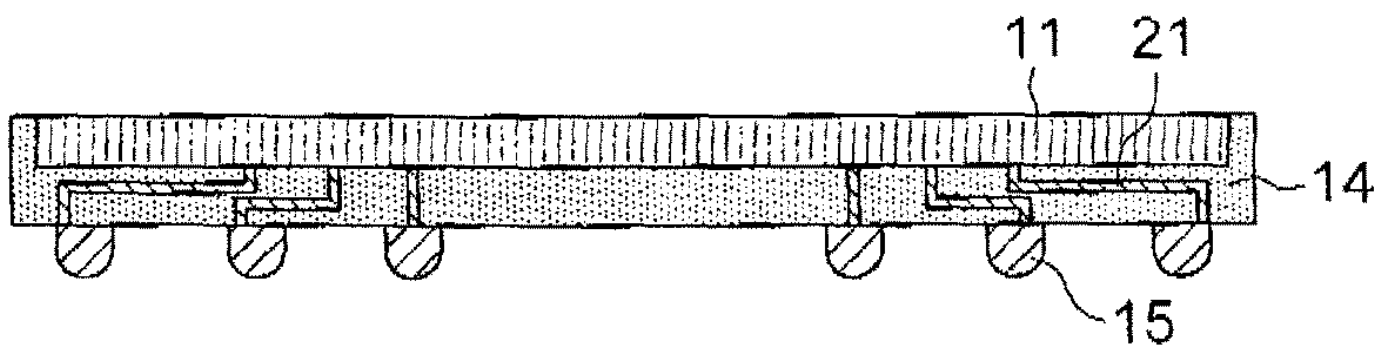

8

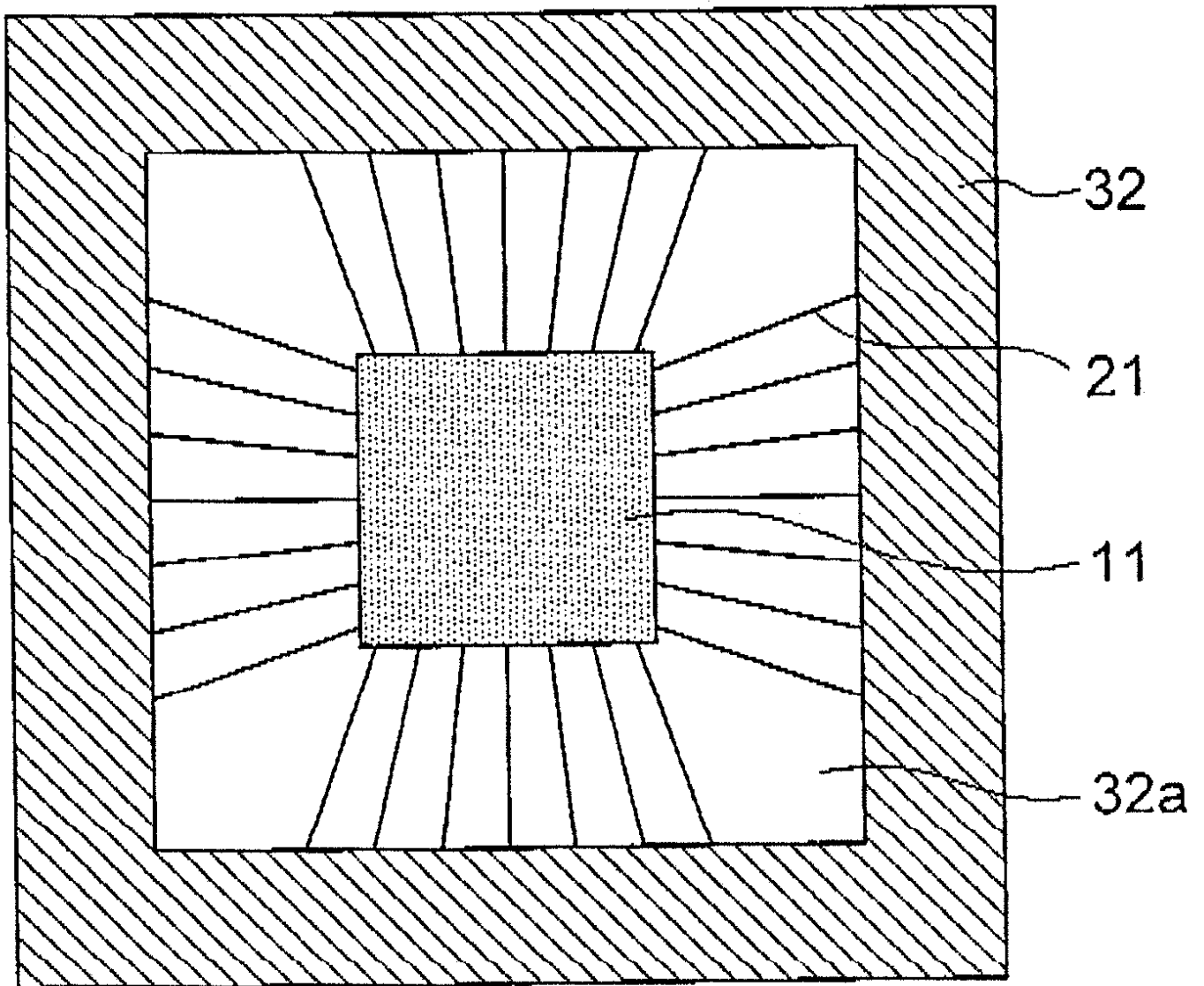

9a

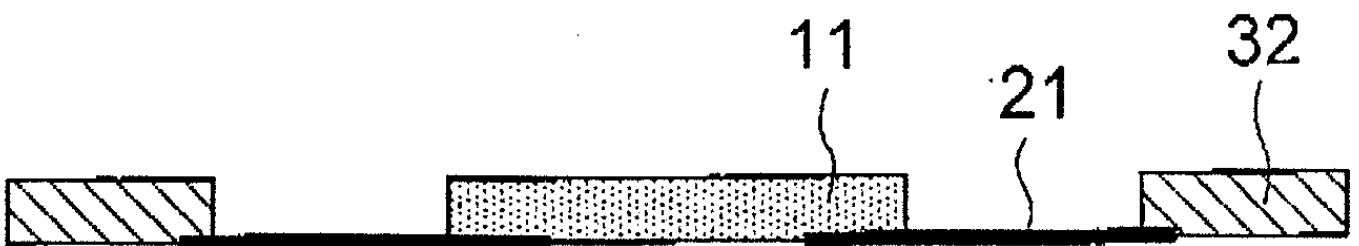

9b

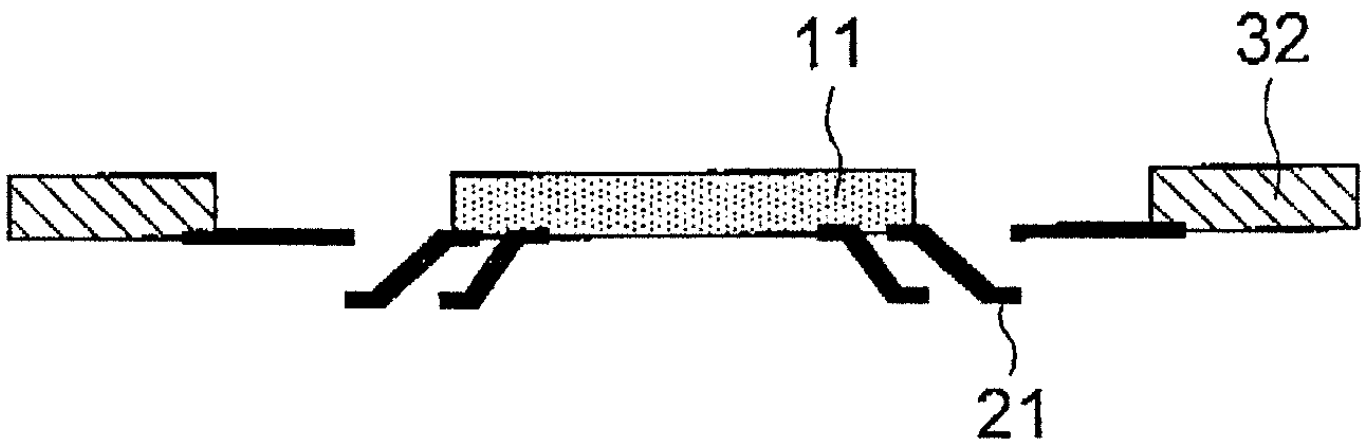

9c

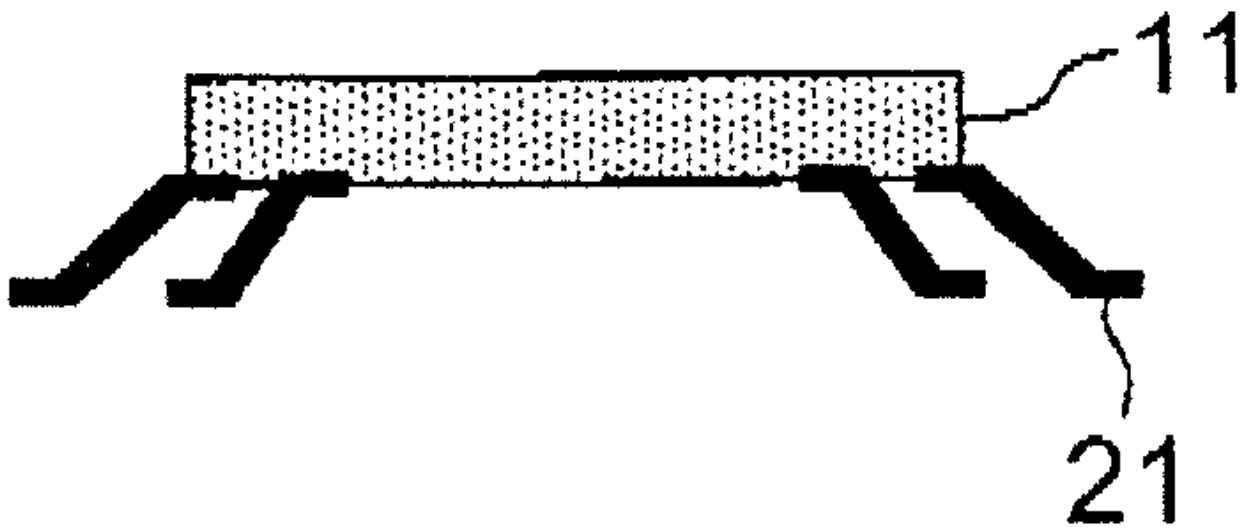

10a



10b

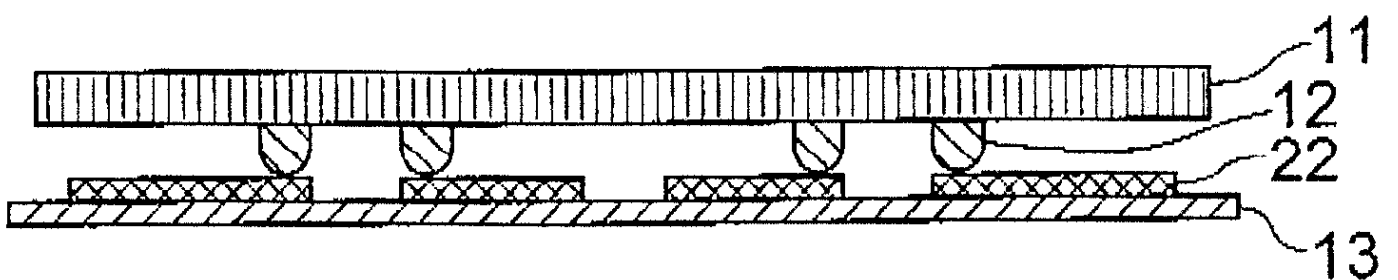

10c

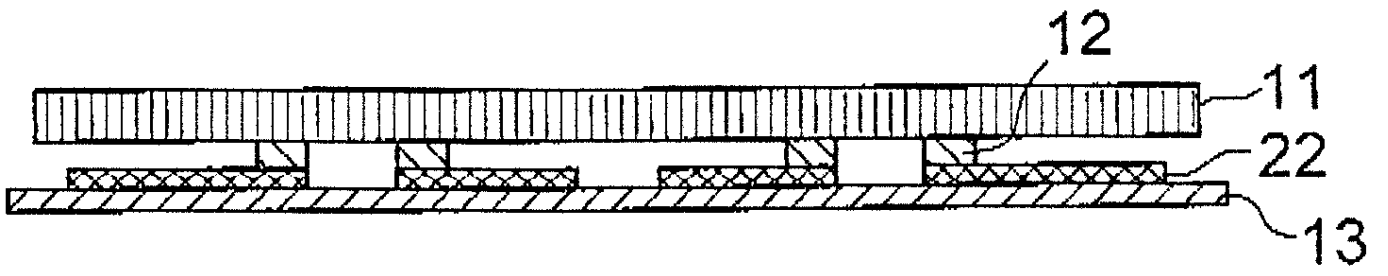

10d

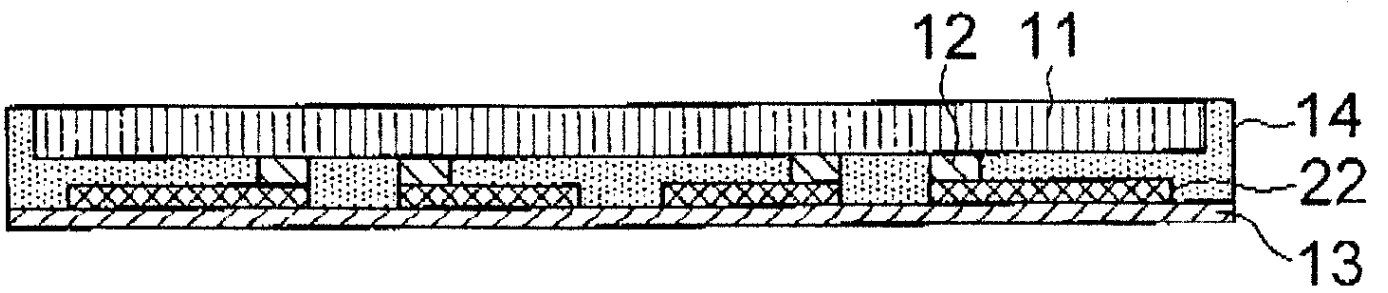

10e

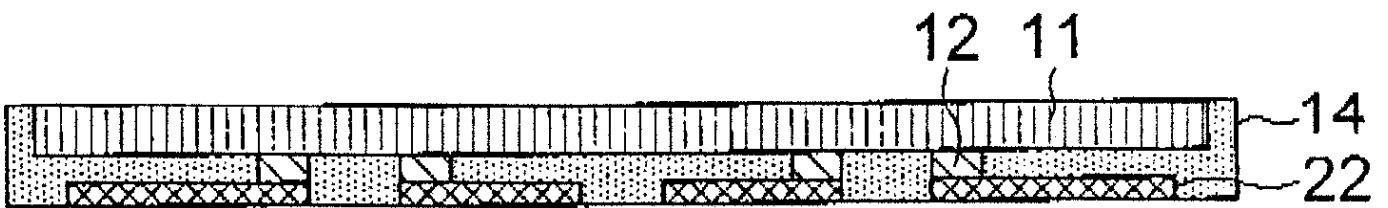

10f

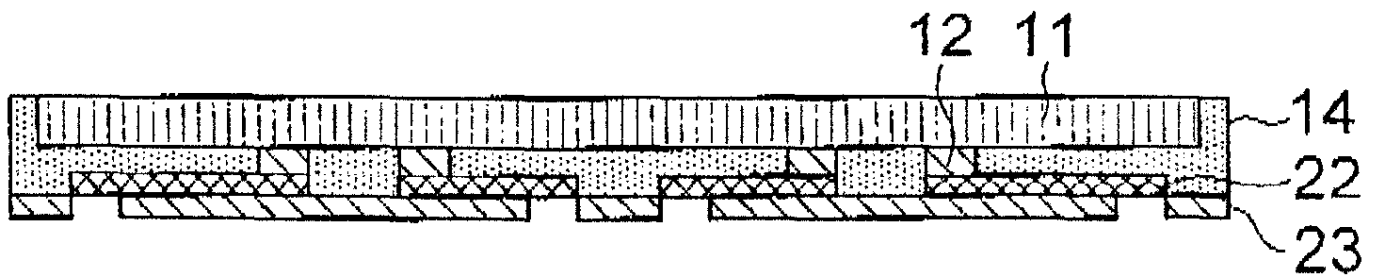

10g

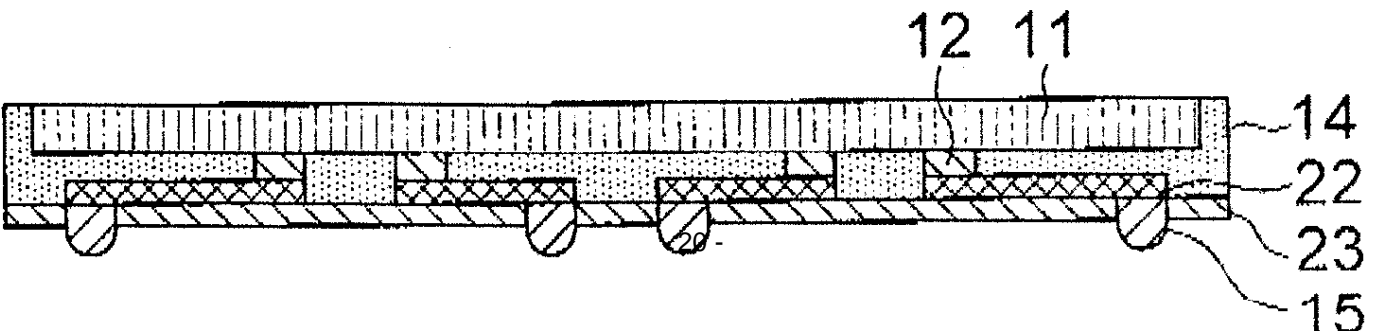

11a



11b

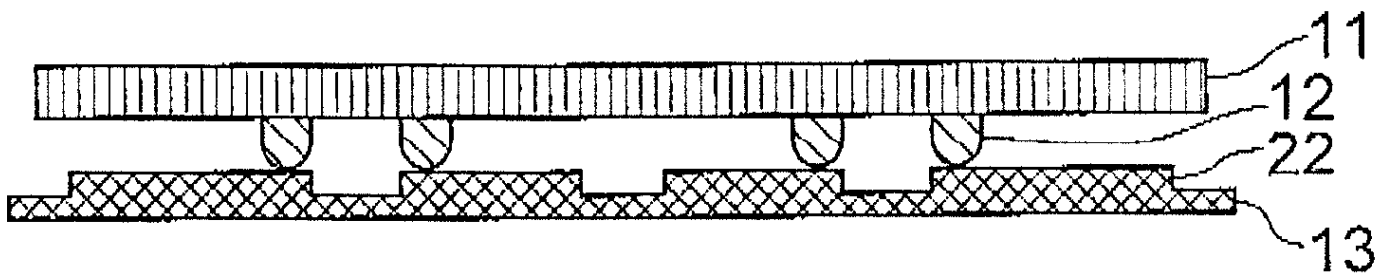

11c

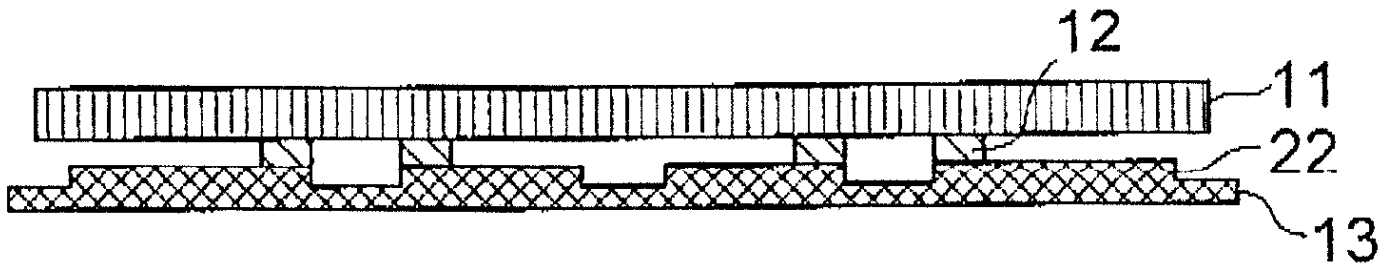

11d

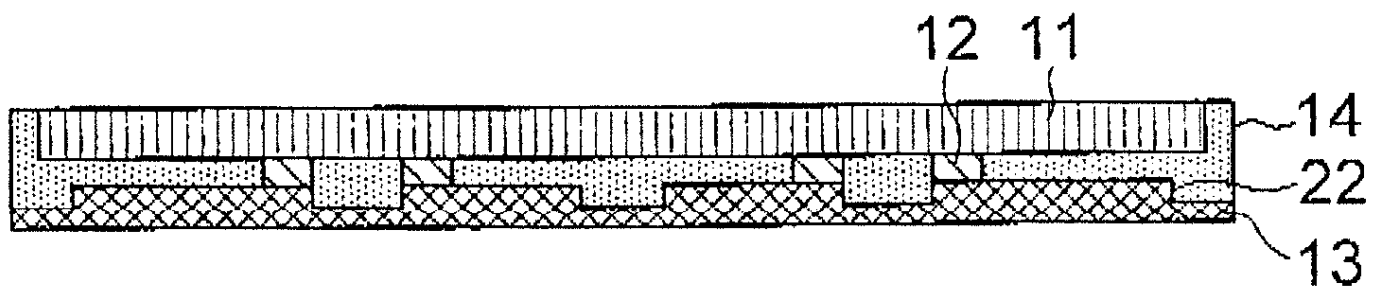

11e

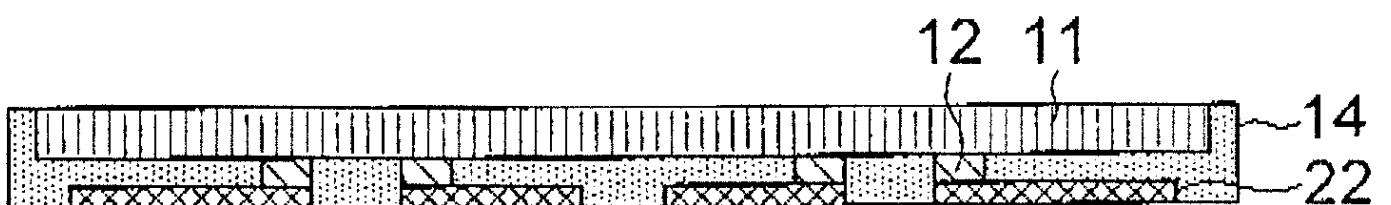

11f

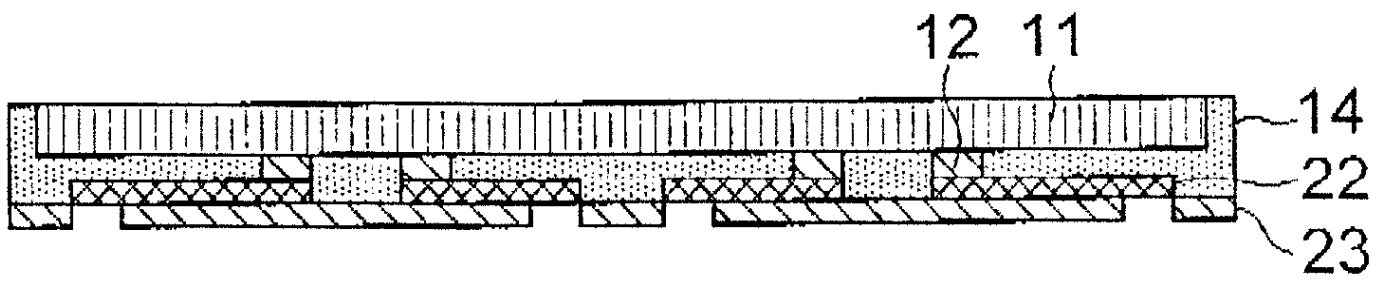

11g

