

**(12) STANDARD PATENT**  
**(19) AUSTRALIAN PATENT OFFICE**

(11) Application No. **AU 2007253683 B2**

(54) Title  
**Method and articles for treatment of stress urinary incontinence**

(51) International Patent Classification(s)  
**A61F 2/02** (2006.01)                      **A61F 2/04** (2006.01)

(21) Application No: **2007253683**                      (22) Date of Filing: **2007.05.21**

(87) WIPO No: **WO07/137226**

(30) Priority Data

(31) Number	(32) Date	(33) Country
<b>60/819,370</b>	<b>2006.07.10</b>	<b>US</b>
<b>60/747,736</b>	<b>2006.05.19</b>	<b>US</b>

(43) Publication Date: **2007.11.29**

(44) Accepted Journal Date: **2012.12.06**

(71) Applicant(s)  
**AMS Research Corporation**

(72) Inventor(s)  
**Longhini, Ross A.;Koullick, Edouard A.;Lund, Robert E.;Presthus, James B.;Buysman, John Jason;Otte, John Fritz**

(74) Agent / Attorney  
**Spruson & Ferguson, Level 35 St Martins Tower 31 Market Street, Sydney, NSW, 2000**

(56) Related Art  
**US 6042534**

(19) World Intellectual Property Organization  
International Bureau



(43) International Publication Date  
29 November 2007 (29.11.2007)

PCT

(10) International Publication Number  
**WO 2007/137226 A3**

(51) International Patent Classification:  
A61F 2/02 (2006.01)

(21) International Application Number:  
PCT/US2007/069370

(22) International Filing Date: 21 May 2007 (21.05.2007)

(25) Filing Language: English

(26) Publication Language: English

(30) Priority Data:  
60/747,736 19 May 2006 (19.05.2006) US  
60/819,370 10 July 2006 (10.07.2006) US

(71) Applicants and

(72) Inventors: OTTE, John, Fritz [US/US]; 2521 Pahl Avenue, St. Anthony, MN 55418 (US). LUND, Robert, E. [US/US]; 9686 41st Place Circle NE, St. Michael, MN 55376 (US). BUYSMAN, John, Jason [US/US]; 16619 Temple Drive North, Minnetonka, MN 55345 (US). KOULLICK, Edouard, A. [NL/US]; 416 Natchez Avenue South, Golden Valley, MN 55416 (US). LONGHINI, Ross, A. [US/US]; 1299 O'Ryan Trail North, Stillwater, MN 55082 (US). PRESTHUS, James, B. [US/US]; 5859 Long Blake Trail, Edina, MN 55439 (US).

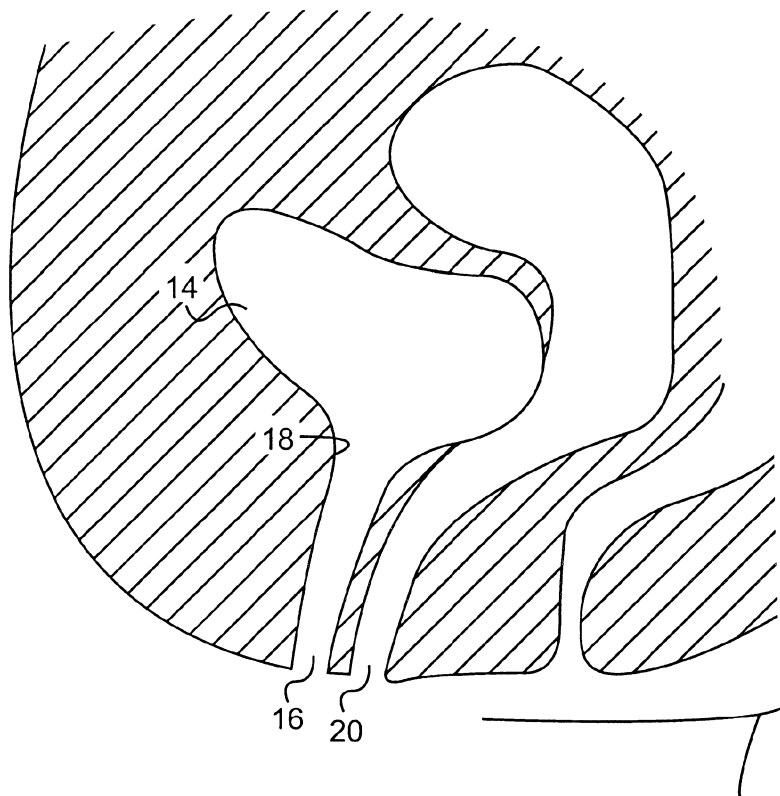
(74) Agent: SCHULTE, Daniel, C.; Kagan Binder, PLLC, Suite 200, Maple Island Building, 221 Main Street North, Stillwater, MN 55082 (US).

(71) Applicant (for all designated States except US): AMS RESEARCH CORPORATION [US/US]; 10700 Bren Road West, Minnetonka, MN 55343 (US).

(81) Designated States (unless otherwise indicated, for every kind of national protection available): AE, AG, AL, AM, AT, AU, AZ, BA, BB, BG, BH, BR, BW, BY, BZ, CA, CH, CN, CO, CR, CU, CZ, DE, DK, DM, DZ, EC, EE, EG, ES,

[Continued on next page]

(54) Title: METHOD AND ARTICLES FOR TREATMENT OF STRESS URINARY INCONTINENCE



(57) Abstract: Improved methods and apparatuses for treatment of incontinence or pelvic organ prolapse are provided. A neo ligament for increasing the supportive function of the tissues supporting the urethra, bladder neck, or rectum is disclosed. Methods of using such a neoligament to treat incontinence are disclosed. Additionally, a self tensioning elastic tissue bolster for support of the tissues that support the urethra, rectum, and bladder neck are disclosed. A method of treating incontinence by injecting proliferative agents into supportive structures is disclosed. Methods and apparatus for transvaginal and transperitiaeai pelvic floor bolster treatment of incontinence and bladder pillar systems are also disclosed.

WO 2007/137226 A3



FI, GB, GD, GE, GH, GM, GT, HN, HR, HU, ID, IL, IN, IS, JP, KE, KG, KM, KN, KP, KR, KZ, LA, LC, LK, LR, LS, LT, LU, LY, MA, MD, ME, MG, MK, MN, MW, MX, MY, MZ, NA, NG, NI, NO, NZ, OM, PG, PH, PL, PT, RO, RS, RU, SC, SD, SE, SG, SK, SL, SM, SV, SY, TJ, TM, TN, TR, TT, TZ, UA, UG, US, UZ, VC, VN, ZA, ZM, ZW.

**(84) Designated States** (*unless otherwise indicated, for every kind of regional protection available*): ARIPO (BW, GH, GM, KE, LS, MW, MZ, NA, SD, SL, SZ, TZ, UG, ZM, ZW), Eurasian (AM, AZ, BY, KG, KZ, MD, RU, TJ, TM),

European (AT, BE, BG, CH, CY, CZ, DE, DK, EE, ES, FI, FR, GB, GR, HU, IE, IS, IT, LT, LU, LV, MC, MT, NL, PL, PT, RO, SE, SI, SK, TR), OAPI (BF, BJ, CF, CG, CI, CM, GA, GN, GQ, GW, ML, MR, NE, SN, TD, TG).

**Published:**

— *with international search report*

**(88) Date of publication of the international search report:**

17 April 2008

Method and Articles for Treatment of Stress Urinary Incontinence

## BACKGROUND OF THE INVENTION

### FIELD OF THE INVENTION

5 [0001] This invention relates to urogenital medicine and surgery.

### DESCRIPTION OF THE RELATED ART

[0002] Over 13 million American men and women of all ages suffer from urinary incontinence. The social implications for an incontinent patient include loss of self-esteem, embarrassment, restriction of social and sexual activities, isolation, depression and, in some instances, dependence on caregivers. Incontinence is the most common reason for institutionalization of the elderly.

[0003] The urinary system consists of the kidneys, ureters, bladder and urethra. The bladder is a hollow, muscular, balloon-shaped sac that serves as a storage container for urine. The bladder is located behind the pubic bone and is protected by the pelvis. Ligaments hold the bladder in place and connect it to the pelvis and other tissue. FIG. 1 schematically illustrates female anatomy. The urethra 16 is the tube that passes urine from the bladder 14 out of the body. The narrow, internal opening of the urethra 16 within the bladder 14 is the bladder neck 18. In this region, the bladder's bundled muscular fibers transition into a sphincteric striated muscle called the internal sphincter. FIG. 2 schematically illustrates male anatomy. The urethra 16 extends from the bladder neck 18 to the end of the penis 22. The male urethra 16 is composed of three portions: the prostatic, bulbar and pendulus portions. The prostatic portion is the widest part of the tube, which passes through the prostate gland 24.

[0004] Incontinence may occur when the muscles of the urinary system malfunction or are weakened. Other factors, such as trauma to the urethral area, neurological injury, hormonal imbalance or medication side-effects, may also cause or contribute to incontinence. There are five basic types of incontinence: stress incontinence, urge incontinence, mixed incontinence, overflow incontinence, and functional incontinence. Stress urinary incontinence (SUI) is the involuntary loss of urine that occurs due to sudden increases in intra-abdominal pressure resulting from activities such as coughing, sneezing, lifting, straining, exercise and, in severe cases, even simply changing body position. Urge incontinence, also termed "hyperactive bladder" "frequency/urgency syndrome" or "irritable bladder," occurs when an individual experiences the immediate need to urinate and loses bladder control before reaching the

toilet. Mixed incontinence is the most common form of urinary incontinence. Inappropriate bladder contractions and weakened sphincter muscles usually cause this type of incontinence. Mixed incontinence is a combination of the symptoms for both stress and urge incontinence. Overflow incontinence is a constant dripping or leakage of urine caused by an overfilled  
5 bladder. Functional incontinence results when a person has difficulty moving from one place to another. It is generally caused by factors outside the lower urinary tract, such as deficits in physical function and/or cognitive function.

[0005] Stress urinary incontinence is generally thought to be related to hypermobility of the bladder neck or an intrinsic urethral sphincter defect .

10 [0006] A variety of treatment options are currently available to treat incontinence. Some of these treatment options include external devices, behavioral therapy (such as biofeedback, electrical stimulation, or Kegal exercises), injectable materials, prosthetic devices and/or surgery. Depending on age, medical condition, and personal preference, surgical procedures can be used to completely restore continence.

15 [0007] Conservative management of stress urinary incontinence can include lifestyle changes, such as weight loss, smoking cessation, and modification of intake of diuretic fluids such as coffee and alcohol. With regard to surgical treatments, the purported “gold standard” is the Burch Colposuspension, in which the bladder neck is suspended. Mid-urethral slings have been similarly effective. One type of procedure, found to be an especially successful  
20 treatment option for SUI in both men and women, is a sling procedure.

[0008] A sling procedure is a surgical method involving the placement of a sling to stabilize or support the bladder neck or urethra. There are a variety of different sling procedures. Slings used for pubovaginal procedures differ in the type of material and anchoring methods. In some cases, the sling is placed under the bladder neck and secured via suspension sutures  
25 to a point of attachment (e.g. bone) through an abdominal and/or vaginal incision. Examples of sling procedures are disclosed in U.S. Pat. Nos. 5,112,344; 5,611,515; 5,842,478; 5,860,425; 5,899,909; 6,039,686, 6,042,534, 6,110,101, and 6.652,450, all of which are herein incorporated by reference.

[0009] Although serious complications associated with sling procedures are infrequent, they  
30 do occur. Complications include urethral obstruction, development of de novo urge incontinence, hemorrhage, prolonged urinary retention, infection, and damage to surrounding tissue and sling erosion.

[0010] As noted above, injectable materials are an option for treatment of stress urinary incontinence. These have generally consisted of the injection of bulking agents into tissues

surrounding the urethra to allow these tissues to better support the urethra, and help the urethral sphincter function properly. Collagen is sometimes used. Carbon coated beads are also used. Certain polymers have also been used. All of these injectable agents have the disadvantage of requiring multiple repeated treatments to maintain efficacy.

[0011] Prolotherapy is a technique wherein sclerosing substances, such as dextrose, are injected into musculoskeletal structures to induce changes in the ligaments and tendons due to increased proliferation of the tissue. This technique is also used in treatment of ocular conditions. In these techniques, the substance is injected. This leads to localized inflammation, which leads to the wound healing process. This results in a deposition of new collagen, which shrinks as it heals. The shrinking collagen tightens the ligaments. These techniques have not been applied to urologic disorders. These techniques are further described Ligament and Tendon Relaxation Treated by Prolotherapy, by George S, Hackett, which is herein incorporated by reference in its entirety.

[0012] There is a desire for a minimally invasive yet highly effective treatment modality that can be used with minimal to no side effects. Such a modality should reduce the complexity of a treatment procedure, be biocompatible, should reduce pain, operative risks, infections and post operative hospital stays, and have a good duration of activity. Further, the method of treatment should also improve the quality of life for patients.

## **OBJECT OF THE INVENTION**

[0012a] It is the object of the present invention to substantially overcome or at least ameliorate one or more of the above disadvantages.

## **SUMMARY OF THE INVENTION**

[0013] There is disclosed herein a method of treating incontinence comprising placing a neoligament in at least one of an obturator internus, obturator membrane, space of retzius, white line, levator ani muscles, endopelvic fascia, rectum, and puborectalis muscles, wherein said neoligament is formed in situ.

[0013a] There is further disclosed herein a method of treating pelvic floor prolapse comprising placing a neoligament in at least one of an obturator internus, obturator membrane, space of

retzius, white line, levator ani muscles, endopelvic fascia, rectum, and puborectalis muscles, wherein said neoligament is formed in situ.

[0014] The present disclosure concerns methods for urological applications, particularly for the treatment of stress and/or urge urinary incontinence, fecal incontinence, and prolapse and perineal floor repairs.

[0015] As noted, the usual treatments for stress urinary incontinence include placing a sling to either compress the urethral sphincter or to elevate or support the neck of the bladder defects. In the present invention, hypermobility in the female or male stress urinary incontinence patient is treated by use of a neoligament.

[0016] For purposes of the present disclosure, the term neoligament is used to describe a synthetic, tissue, or composite tissue/synthetic structure that has the fixation, stiffness, and strength required to support the urethra, rectum, or pelvic floor muscles during a stress event such that the symptoms of stress urinary or fecal incontinence are reduced or eliminated.

[0017] In the present disclosure, a neoligament may be formed from any suitable material, for example, any suitable polymeric product, such as expanded polytetrafluoroethylene, polypropylene, polyethylene terephthalate, or polycarbonate urethane, hydrogel, or a resorbable or nonresorbable biological material. The neoligament may be formed into any suitable configuration, for example, a knitted, woven, braided, barbed, tubular, or stent-like configuration.

[0018] The present disclosure also includes several methods for use of a neoligament for treating several pelvic conditions including, but not limited to, stress and/or urge urinary incontinence and fecal incontinence, and pelvic or perineal floor repairs in both male and female patients. The methods comprise forming the neoligament in situ. This method may include steps of injecting a fibrosing agent through a tube needle, or other suitable device into the obturator internus, obturator membrane, space of retzius, endopelvic fascia and/or perineal floor. The fibrosing agent may be in the form of a liquid, gel, foam, solid, or a solution containing the fibrosing agent. The fibrosing agent can be any suitable agent.

[0019] The present disclosure also encompasses a self-tensioning elastic tissue bolster which can be, similar to the neoligament, implanted into the tissues that support the urethra, bladder, rectum, pelvic, or perineal floor. Similar to the neoligament, such a tissue bolster has the advantage of requiring minimal surgery, thus being amenable to in-office outpatient implantation. Such bolster implants would have efficacy similar to sling treatment of stress incontinence. However, the device is made to be of such a small size that it can be implanted through a small incision or puncture, with minimal bleeding, pain, and complications.

[0020] The present disclosure also encompasses a method of treating various forms of incontinence or effecting pelvic floor repair by using an injectable agent to shrink the collagen in the ligaments and other tissues that support the urethra, bladder, rectum, and pelvic floor. Further, such injections can be used to alter the collagen in the urethra, as such a change in collagen structure may increase the resistance to urine flow through the urethra, or to correct the ano-rectal angle for fecal incontinence. Such treatment is minimally invasive and is a targeted treatment with minimal adverse side effects.

[0021] The present disclosure also encompasses transvaginal or transperineal urethral bolster systems.

[0022] The present disclosure also encompasses bladder or rectal pillar systems.

[0023] While reference is made to use of the disclosed neoligament, tissue bolster devices, and collagen alteration methods for treatment of stress urinary incontinence, it is clear that such techniques and devices are equally applicable to treatment of pelvic organ prolapse conditions, such as cystocele and rectocele. Further, such methods may be adaptable to treatment of fecal incontinence. Accordingly, such treatments are within the scope of the present disclosure.

#### **BRIEF DESCRIPTION OF THE DRAWINGS**

[0024] A more complete appreciation of the invention and many of the attendant advantages thereof will be readily obtained as the same becomes better understood by reference to the following detailed description when considered in connection with the accompanying drawings, wherein:



- [0025] Fig. 1 shows a schematic view of the female urinary system;
- [0026] Fig. 2 is a schematic view of the male urinary system;
- [0027] Figs. 3A and 3B are views of the injection of fibrosing agent to form a neoligament;
- [0028] Fig. 4A and 4B are views of the introduction of a formed neoligament into its proper location;
- [0029] Figs. 5 A shows the lax tissue causing hypermobility of the urethra;
- [0030] Fig. 5B shows the self-tensioning elastic tissue bolster with the springs relaxed;
- [0031] Fig. 5C shows the self-tensioning elastic tissue bolster with the springs elongated;
- [0032] Fig. 5D shows a tool for implantation of the self-tensioning elastic tissue bolster;
- [0033] Fig. 5E shows another aspect of a tool for implantation of the self-tensioning elastic tissue bolster;
- [0034] Fig. 5F shows an embodiment of the self-tensioning elastic tissue bolster;
- [0035] Fig. 5G shows another embodiment of the self-tensioning elastic tissue bolster;
- [0036] Fig. 6A shows another embodiment of the self-tensioning elastic tissue bolster;
- [0037] Fig. 6B shows another embodiment of the self-tensioning elastic tissue bolster;
- [0038] Fig. 6C shows another embodiment of the self-tensioning elastic tissue bolster;
- [0039] Fig. 6D shows another embodiment of the self-tensioning elastic tissue bolster;
- [0040] Fig. 6E shows another embodiment of the self-tensioning elastic tissue bolster;
- [0041] Fig. 6F shows another embodiment of the self-tensioning elastic tissue bolster;

[0042] Fig. 7A shows another embodiment of the self-tensioning elastic tissue bolster;

[0043] Fig. 7B shows another embodiment of the self-tensioning elastic tissue bolster;

[0044] Fig. 7C shows another embodiment of the self-tensioning elastic tissue bolster;

[0045] Fig. 7D shows another embodiment of the self-tensioning elastic tissue bolster;

[0046] Figs. 7E-7F show another embodiment of the tool for Implantation of the self-tensioning elastic tissue bolster.

[0047] Fig. 8A-8C show another embodiment of the tool for implantation of the self-tensioning elastic tissue bolster.

[0048] Fig. 9A-9C show another embodiment of the tool for implantation of the self-tensioning elastic tissue bolster.

5 [0049] Fig. 9D shows another embodiment of the self-tensioning elastic tissue bolster.

[0050] Fig. 10A-10C show another embodiment of the self-tensioning elastic tissue bolster.

[0051] Fig. 11 shows an embodiment of the method of treating incontinence by prolotherapy.

10 [0052] Fig. 12 shows another embodiment of the method of treating incontinence by prolotherapy.

[0053] Fig. 13 shows another embodiment of the method of treating incontinence by prolotherapy.

[0054] Fig. 14 shows an embodiment of the transvaginal urethral bolster needle introducer.

[0055] Fig. 15 shows an embodiment of the transvaginal urethral bolster.

15 [0056] Fig. 15A shows an embodiment of the transvaginal urethral bolster.

[0057] Fig. 16 shows modifications of the transvaginal urethral bolster.

[0058] Fig. 17 shows the transvaginal urethral bolster in place.

[0059] Fig. 18 shows the transvaginal urethral bolster in place.

[0060] Fig. 19 shows the urethral guide for the bladder pillar system.

20 [0061] Fig. 20 shows a coiled embodiment of the bladder pillar.

[0062] Fig. 21 shows an adjustable embodiment of the bladder pillar.

[0063] Fig. 22 shows an expandable embodiment of the bladder pillar.

[0064] Fig. 23 is an overview of the bladder pillar system.

25                    DETAILED DESCRIPTION OF THE PREFERRED EMBODIMENTS

[0065] Referring now to the drawings, wherein like reference numerals designate identical or corresponding parts throughout the several views. The following description is meant to be illustrative only, and not limiting other embodiments of this invention will be apparent to those of ordinary skill in the art in view of this description.

30 [0066] One aspect of the present invention is a pessary-like device which is used to hold the anterior vaginal wall and tissues deep to the vaginal wall in proper position during the formation of the neoligament. The pessary-like device may be, as clinically appropriate, adjustable. It may be formed to act primarily on the vaginal wall under the urethra, or it may act primarily on the vaginal wall lateral to the urethra. The pessary-like device may be made

from a material including inhibizone, antimicrobial, and or antifungal agents. Further, an adjustable pessary-like device may be adjustable via inflation or deflation of a cuff or bladder in the device. Further, an adjustable pessary-like device may be lengthened or shortened in one direction by inflation or deflation of a cuff or a cylinder that is turned inside-out onto  
5 itself. Further, the pessary-like device may have one or more ports through it for injection of fibrosing agents or placement of a neoligament. Such ports would preferably be placed at such locations to approach the target areas, including the obturator internus, obturator membrane, space of retzius, perineal floor, rectum, and/or endopelvic fascia. The pessary-like device can optionally include a through hole or aperture so as to not occlude the vaginal  
10 canal when the device is in place.

[0067] Another aspect of the present invention is a specialized needle, trocar, introducer, syringe, or tube for placing a formed neoligament or a fibrosing agent. Among preferred embodiments are articulating needles, syringes, or tubes for directing the neoligament or fibrosing agent to the desired target tissue. A preferred embodiment is a curved needle,  
15 syringe, or tube. Another preferred embodiment is a needle, tube, or syringe formed of elastic or super elastic material that curves toward target tissues as it is advanced from a straight introducer.

[0068] Another aspect of the present invention is the method of treating stress urinary incontinence using a neoligament formed in situ, as seen in Fig. 3. The method comprises  
20 arranging the anterior vaginal wall and tissues deep to the vaginal wall in proper position for the formation of the neoligament. The method includes a transvaginal or transperineal injection, and may optionally include use of local anesthesia. A needle, tube, or syringe is used to inject a fibrosing agent into the anterior vaginal wall (or pelvic floor for males), lateral to mid-urethra, and or bladder neck (illustrated as member 1 in Fig. 3), as needed. The  
25 fibrosing agent causes fibrosis in the tissue, resulting in a neoligament for suspension of the anterior vaginal wall and the urethra.

[0069] Another aspect of the present invention is the method of treating stress urinary incontinence using a neoligament formed prior to the procedure, as seen in Fig. 4. This method differs from the in situ method in that a neoligament is implanted into the target  
30 tissue. Such a neoligament may be formed in any conventional method of manufacturing medical implants. This method may also use a transvaginal or transperineal approach. Local anesthetic may be injected into the anterior vaginal wall in the female. The formed neoligament is placed via an appropriate implantation device into the anterior vaginal wall (or pelvic floor for males), lateral to mid-urethra, or bladder neck (illustrated as member 2 in Fig.

4), on both sides, in order to effect a bolstering or suspension effect of the anterior wall of the vagina.

[0070] Another aspect of the present invention is a self-tensioning elastic tissue bolster. An embodiment of the self-tensioning elastic tissue bolster of the present invention may include  
5 a small spring or elastic component that can be implanted into the tissues that support the urethra or bladder neck. In a related embodiment, the spring or stent-like element includes tissue anchors at one or both ends to pull the surrounding tissues in as the spring compresses so as to tighten the area around the urethra, rectum, or pelvic floor. In other embodiments, a material other than a spring, such as a suitably elastic fabric or polymer material, may be used  
10 to form the tissue bolster. The tissue bolsters serve to increase the support provided by the lax support structures, as such laxity contributes to incontinence, as illustrated schematically in Fig. 5A, where member 16 is the urethra or bladder neck and member 4 is the lax support structure.

[0071] The elastic or spring component of the present invention may be implanted in an  
15 elongated state, as illustrated in Fig. 5B, in which the implant is illustrated by member 11. After anchoring the two ends of the implant in tissue by, for example, using tissue anchors as shown in Figs. 5F and 5G, the elastic or spring component 7 is allowed to contract to its natural state, shortening the implant and resulting in increased support to the urethra and bladder neck, as illustrated in Fig. 5C. In addition to supporting the urethra and bladder neck  
20 by increasing the tension in the support tissues, the implant of the present invention also increases the strength of those support tissues by the integration of the implant itself into the tissues and by the tissue healing response initiated by the foreign body reaction, resulting in remodeling of the support tissues. This strengthening function can also be used to address fecal and urge incontinence as well as to simplify pelvic floor and vaginal repairs that can be  
25 performed in an office setting.

[0072] With regard to the tissue anchors, the present invention encompasses any suitable anchor structures. Without limitation, Fig. 5F illustrates an embodiment having anchor structures 5 and 6 attached to one or both ends of the spring or elastic component 7. The spring or elastic component may further include additional grip structure. In a preferred  
30 embodiment, the spring or elastic structure may be provided within a covering structure 8 with attached anchors, as illustrated in a non-limiting example in Fig. 5G.

[0073] In a further embodiment of the tissue bolster of the present invention, the elastic material is held in its elongated position by a bioabsorbable brace after implant into the supporting tissues, as shown in Figs. 6A, 9D, and 10. Such a brace, illustrated as member 12,

allows the body of the patient to heal in such a way that tissue in-growth into the implant occurs. After sufficient period to allow such in-growth to affect an anchor to the ends of the implant (approximately 1 week to 1 month), the brace is absorbed or otherwise removed, at which time the spring contracts to its natural position, resulting in tension in the supporting  
5 tissues and support of the urethra or bladder neck. Similarly, the implant of the present invention may be coated or wrapped in a material that promotes such in-growth of tissue, as shown in Fig. 6B, illustrated as member 13. The growth promoting material may be any such material, including a mesh, a drug coating, or a plastic. The spring or elastic material could be wrapped in fabric, as shown in Fig. 6C, illustrated as member 15.

10 [0074] In a further embodiment, the bioabsorbable brace holding the implant in its elongated state can be built such that it gradually weakens, resulting in more gradual application of the increased tension in the tissues. Such a gradual increase in tension would likely result in less risk of tearing or pain. This can be affected by providing the bioabsorbable brace 12 in a flexed position, such that the brace flexes more as it weakens, as seen in Fig. 10A. In an  
15 alternative embodiment, the bioabsorbable brace can be provided in a capsule with differing kinds or amounts of bioabsorbable material placed in different locations on the brace. The brace capsule could, for example, selectively absorb on the ends of the capsule before absorbing more toward the center of the brace, allowing gradual contraction of the elastic device, as shown in Fig. 10B, with member 17 representing the capsule, member 19  
20 representing the portions of the capsule that absorb most quickly, and member 21 representing the portions of the capsule that absorb most slowly. Likewise, in a further embodiment, a bioabsorbable suture could be used to deploy the elastic device in its elongated state, with the elastic device contracting upon absorption of the suture, as shown in Fig. 10C, with the suture illustrated as member 23.

25 [0075] In another embodiment of the present tissue bolster implant, the implant may be an elastic cloth or polymer. Fig. 6D illustrates an example of such an implant, wherein the elastic implant may be implanted with tissue hooks or anchors 25 to allow initial attachment, followed by contraction of the elastic material 26 or spring or stent-like member, pulling the tissue to which the hooks or anchors are attached more closely together, as shown in Fig. 6E.  
30 In another embodiment, the implant may be of an elastic material in which tissue in-growth is encouraged. In a related embodiment, as the tissue grows into the elastic material, the elastic and the in-grown material are stretched concurrently, as shown in Fig. 6F, resulting in increased tension in the supporting structure and better support of the urethra, bladder neck, or rectum. Such an embodiment is shown in Figs. 7A, 7B, and 7C. Member 26 represents

the stretched elastic implant, member 27 represents the tissue ingrowth into the elastic implant, and member 28 represents the contracted elastic with ingrown tissue, in its tightened condition.

5 [0076] In a further embodiment of the tissue bolster of the present invention, the implant may further include a mechanism that can contract the implant and tension the tissue an adjustable degree as determined by the physician at the time of implantation. Such an embodiment may include a spring with tissue anchors at each end.

10 [0077] In a further embodiment, the implant elastic material of the present invention includes a spring or elastic material surrounded by a cloth or polymer coating that is coated with tissue anchors 29, as shown in Fig. 7D.

[0078] The present invention also encompasses a tool for implanting the implant of the present invention. The tool may be of any design suitable for holding the spring or elastic component in an elongated condition until removal of the tool, at which time the spring or elastic component contracts to its more natural condition. An example of such a tool is  
15 illustrated in Figs. 5D (with the implant elongated) and 5E (with the implant contracted following removal of the tool). The tool may include a handle 9 and an insertion structure 10.

[0079] In another embodiment, the implantation tool includes features for the manual adjustment of the tension in the implant during the implantation procedure. Such features may include features illustrated in Fig. 7E and 7F. This type of implantation tool may be  
20 effectively used to place a non-elastic or non-spring implant, as the implant material can be tensioned manually by the operator. For example, Fig. 7E illustrates an implant 30 having hooks or anchors 31 that are engaged in the lax tissue. By engaging a squeeze device 32 on the handle, the implant is contracted, pulling the engaged tissue points more closely together, and tensioning the lax tissue. Other related implant tools are illustrated in U.S. Patent  
25 Publication 2002/0161382 and 2004/0039453, which are herein incorporated by reference in their entirety.

[0080] In a further embodiment of an implantation tool, the tool may include a handle and an insertion structure for holding the elastic device in an elongated state while inserting it. Figs. 8A-C illustrate an embodiment of an implantation tool for implanting an elastic implant  
30 device having tissue anchors covering the implant 33. The implantation tool may include a sheath 31 to cover such anchors during implantation, as shown in Figs. 8A-8C. The implantation tool may further include a mechanism 32 for placing the implant 33. When actuated, the mechanism 32 places the implant, and the sheath 31 is withdrawn. The implant is contracted, pulling the tissue together at the ends of the implant. This is further facilitated

by having tissue anchors disposed in opposite directions on opposite ends of the implant. Tension in the lax supporting tissues is thus increased.

[0081] As illustrated in a non-limiting example in Figs. 9A-9C, a further embodiment of an implantation tool may include a detachable handle 34, a mechanism for holding the  
5 implantable elastic device in an elongated state 35, and relatively long anchors 36 proximal and distal to the elongated elastic or spring device 37. The mechanism 35 can actuate the anchors, such as by pulling the anchors together, as shown in Figs. 9A-9C. The elongated device is placed in the appropriate location such that the hooks on each side of the elongated device engage tissue requiring further tension. When the tissue is engaged by the hooks, the  
10 anchors are actuated, pulling the anchors together, and allowing for contraction of the elastic device and increased tension in the engaged tissue. Upon actuation of the anchors, the implantation tool handle is detached from the implanted elastic device and the handle is removed.

[0082] Another aspect of the present invention is a method of treating stress urinary  
15 incontinence using prolotherapy. An injectable agent is used to shrink the collagen in the ligaments and other tissues that support the urethra, bladder, and pelvic floor. Further, such injections can be used to alter the collagen in the urethra, as such a change in collagen structure may increase the resistance to urine flow through the urethra.

[0083] In an embodiment of the present invention, an injectable agent is injected into the  
20 tissues that support the urethra, indicated by member 39 in Fig. 11, or bladder neck. The injectable agent may include one or more of saline, dextrose, and other known proliferation agents (which include phenol, glycerine, and morrhuate sodium). Any suitable and appropriate supportive tissue is amenable to such injection, including pubocervical fascia, as shown in Fig. 11, and indicated by member 38. Other preferred locations include the  
25 pubourethral ligament, the lateral pubovesical ligament, the arcus tendon of the levator ani muscle, in and about the puborectalis muscle, and the perineal floor. The injections result in a healing process wherein collagen is formed. As the newly formed collagen shrinks, the injected structure tightens, thereby improving in its supportive function.

[0084] In another embodiment, the injectable agents described are injected into the urethra,  
30 as in the posterior wall of the urethra shown in Fig. 12. This injection is facilitated by use of small needles that cannot pierce the urethra and enter the lumen of the organ. Further, the invention includes inserting a balloon or other inflatable marking device 40 into the urethra 16, then inflating the balloon, as illustrated in Fig. 12. Following such inflation, the injectable agents can easily be injected into the wall 41 of the urethra without penetrating the



lumen. Injection into all sides of the tubular organ is shown in Fig. 13A, with the thickened wall post-therapy illustrated in Fig. 13B.

[0085] The present invention also encompasses a transvaginal or transperineal urethral, rectal, or pelvic floor bolster system. This system includes a needle introducer 45, a non-limiting example of which is illustrated in Fig. 14, and may include an elongated needle 42 with a hollow sheath 43. Optionally, markings 44 on the sheath indicate depth of placement. Other methods of indicating depth of placement also fall within the scope of the present invention. The system also includes a bolster, a non-limiting example of which is illustrated in Fig. 15. The bolster 46 may be wrapped and compressed in a plastic covering 47, and is dimensioned to be placed through the introducer. The bolster is preferably formed of a mesh material. The bolster includes sutures 48 on each end. The bolster may preferably include a high friction surface, indicated by member 49 in Fig. 15. The bolster may include anchoring structures, examples of which are illustrated in Fig. 16, including barbs 50 or corkscrews 51. Other anchoring structures are also within the scope of the present invention.

[0086] The present invention also encompasses a method of treating urinary stress or urge incontinence by use of transvaginal urethral bolsters. The method includes local anesthesia infiltration into the paravaginal fascia at the midurethral level, towards the urogenital diaphragm. Following such infiltration, a needle introducer is inserted. The needle is removed, leaving the sheath in place. A bolster is inserted through the sheath. The sheath of the introducer is withdrawn, and the mesh material in the bolster is released. The mesh material expands and is held in place by friction or by anchoring structures. As illustrated in Fig. 17, the bolsters 46 are placed with the sutures extending into the vagina 50. The sutures connected to the mesh material are tied in the vagina over a bolster that compresses the vagina toward the urogenital diaphragm, as illustrated in Fig. 18. This tightens the paravaginal fascia and reduces urethral hypermobility. The amount of tension can be adjusted to prevent urethral obstruction. As the paravaginal fascia grows into the mesh, the urethra is stabilized. After tissue ingrowth, the sutures in the vagina are cut.

[0087] The present invention also encompasses bladder pillars. These pillars provide lateral urethral support and induce new collagen growth. The surgeon identifies the mid-urethra area, which has the greatest urethral pressure, and places a pillar through the vaginal mucosa into the paravaginal fascia to support this region of the urethra. Fig. 23 shows the schematic placement of bladder pillars.

[0088] The bladder pillar system requires identification of the mid-urethra area in order to effect proper placement. The present invention encompasses a urethral guide/template for

such identification. An example is illustrated in Fig. 19. The urethral guide may include indicia to allow location of the correct placement.

[0089] The bladder pillar may be of several different configurations. Fig. 20 shows an embodiment in which the pillar is coiled. Such a coiled pillar 51 may be placed by screwing  
5 into place, compressing the tissue as it is advanced.

[0090] The bladder pillar may be adjustable. Fig. 21 illustrates an example of such an adjustable pillar. The adjustable pillar 52 may include a self-anchoring tip 53. The body 54 of the pillar may optionally include prolene or may be absorbable. Sutures 55 for adjusting the length of the body of the pillar extend into the vagina following placement. An  
10 adjustable slip button 56 is situated on the vaginal side to adjust the tension and hold the pillar in place until tissue in-growth has occurred.

[0091] The bladder pillar may also be expandable. Fig. 22 illustrates an example of an expandable pillar. The expandable pillar 60 includes a probe 57 with an expandable side 58 located toward the urethra. The pillar can be inflated through an injection site 59 with saline  
15 to exert lateral pressure on the urethra. Adding or removing saline can be used to adjust the pressure over time.

[0092] Numerous modifications and variations of the present invention are possible in light of the above teachings. Further, these techniques and devices are described as treatment for urinary incontinence. Their use in treating organ prolapse and other urologic conditions is  
20 also contemplated. It is therefore to be understood that within the scope of the appended claims, the invention may be practiced otherwise than as specifically described herein.

**CLAIMS**

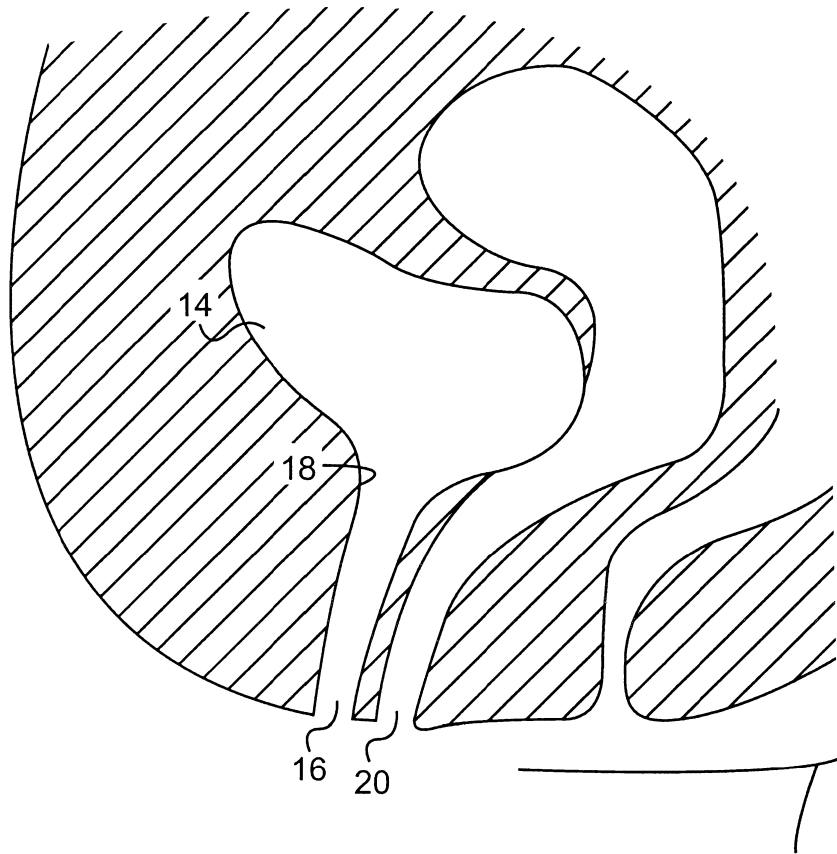
1. A method of treating incontinence comprising:  
placing a neoligament in at least one of an obturator internus, obturator membrane, space of retzius, white line, levator ani muscles, endopelvic fascia, rectum, and puborectalis muscles, wherein said neoligament is formed in situ.
2. The method of claim 1, wherein said neoligament is placed either transvaginally or transperineally.
3. A method of treating pelvic floor prolapse comprising:  
placing a neoligament in at least one of an obturator internus, obturator membrane, space of retzius, white line, levator ani muscles, endopelvic fascia, rectum, and puborectalis muscles, wherein said neoligament is formed in situ.
4. The method of claim 3, wherein said pelvic floor prolapse is a rectocele or a cystocele.
5. The method of claim 1, 2 or 3, wherein the step of placing the neoligament comprises injecting a fibrosing agent through a tube, needle, or other suitable device into the obturator internus, obturator membrane, space of retzius, endopelvic fascia, or perineal floor.
6. The method of claim 1, 2 or 3, wherein the fibrosing agent is present in a composition selected from the group consisting of a liquid, a gel, a foam, a solid, and a solution.
7. A method of treating incontinence, substantially as hereinbefore described with reference to the accompanying drawings.
8. A method of treating pelvic floor prolapse, substantially as hereinbefore described with reference to the accompanying drawings.

**Dated 19 October, 2012**

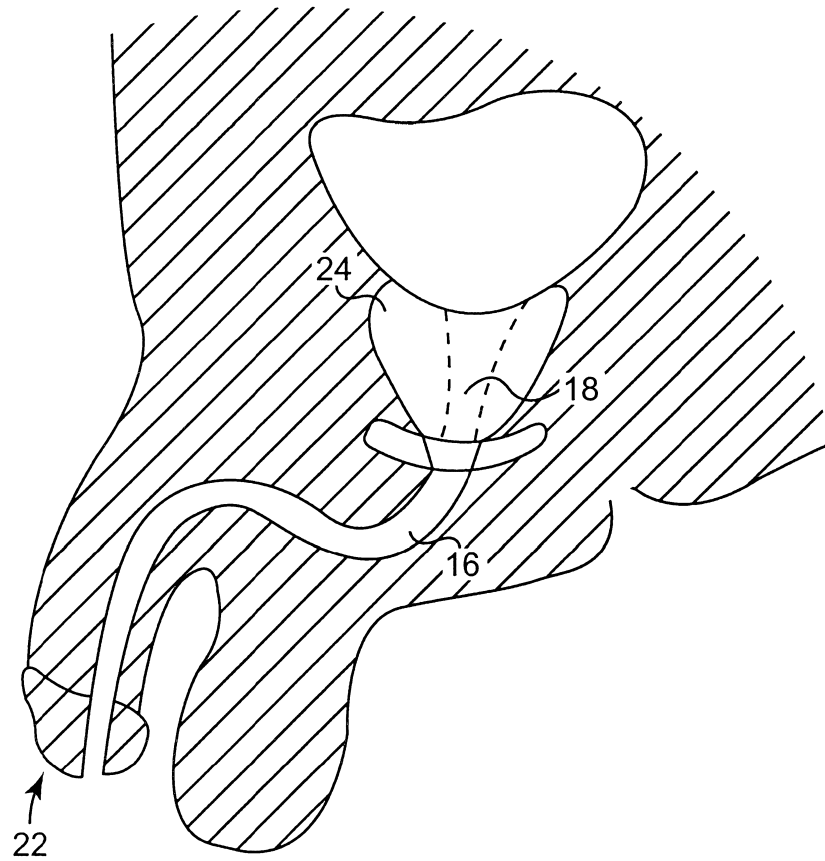
**AMS Research Corporation**

**Patent Attorneys for the Applicant/Nominated Person**

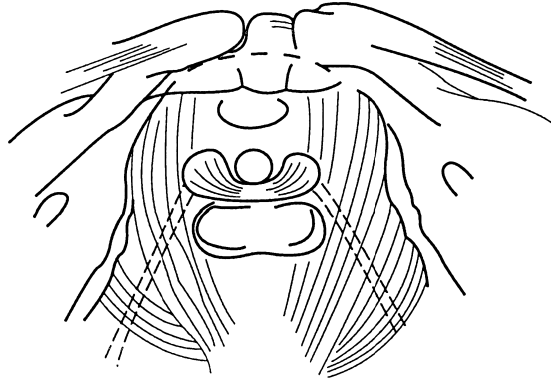
**SPRUSON & FERGUSON**



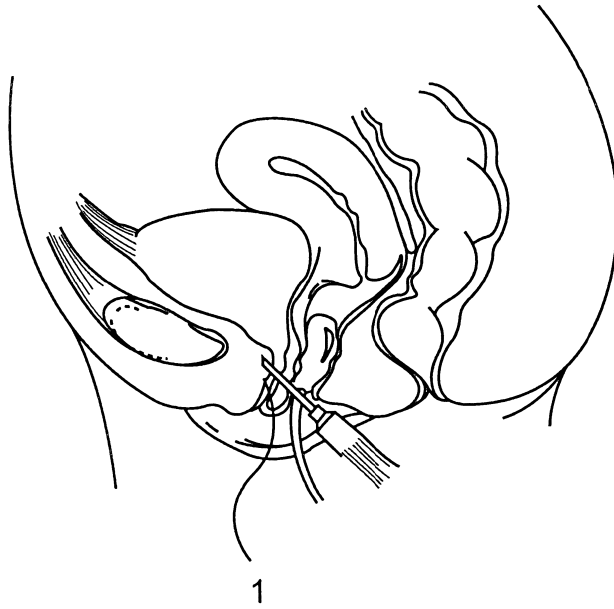
**Fig. 1**



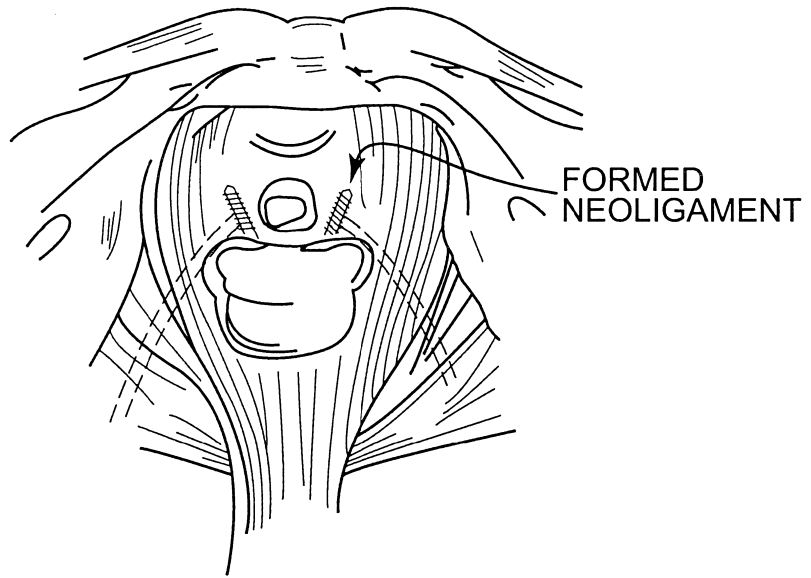
**Fig. 2**



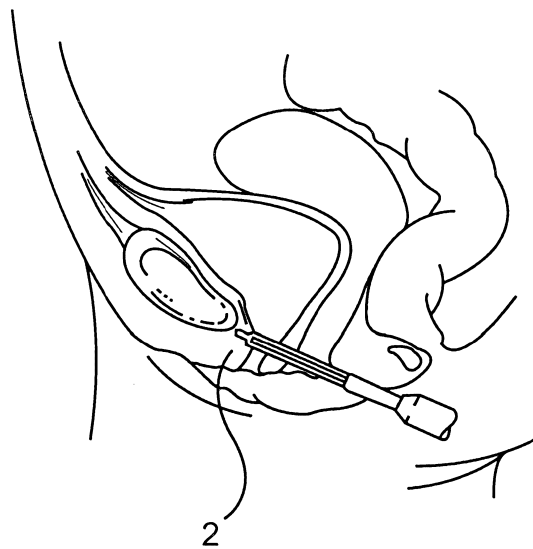
**Fig. 3B**



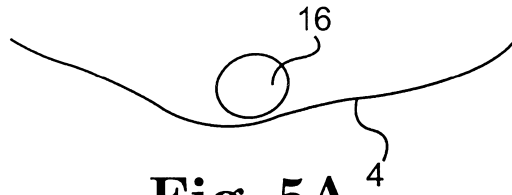
**Fig. 3A**



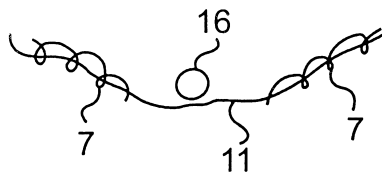
**Fig. 4B**



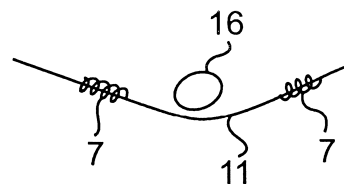
**Fig. 4A**



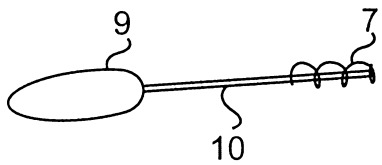
**Fig. 5A**



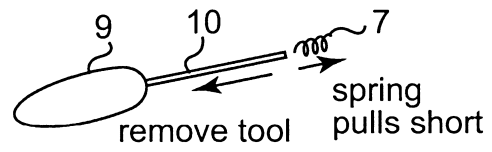
**Fig. 5B**



**Fig. 5C**



**Fig. 5D**



**Fig. 5E**



**Fig. 5F**

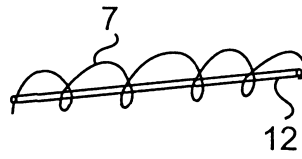
or



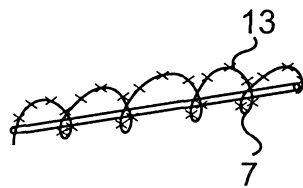
**Fig. 5G**



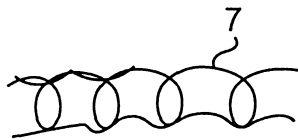
6/15



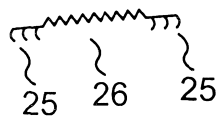
**Fig. 6A**



**Fig. 6B**



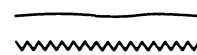
**Fig. 6C**



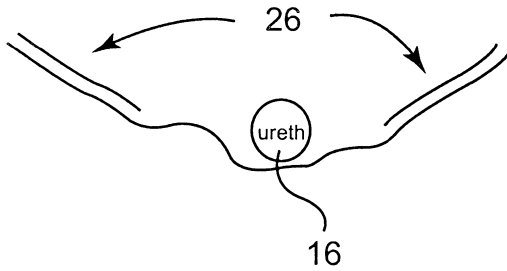
**Fig. 6D**



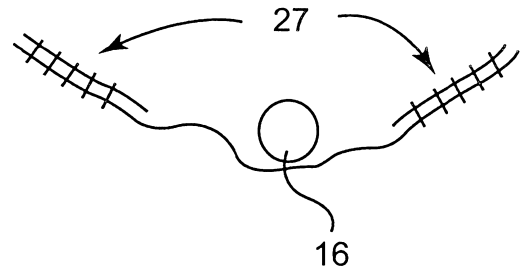
**Fig. 6E**



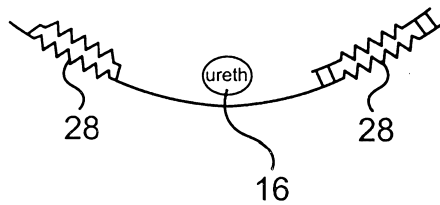
**Fig. 6F**



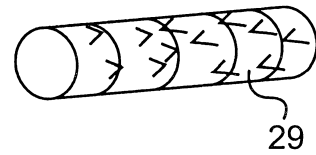
**Fig. 7A**



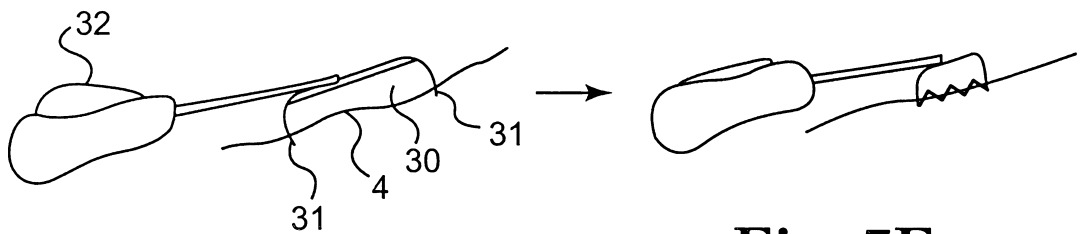
**Fig. 7B**



**Fig. 7C**

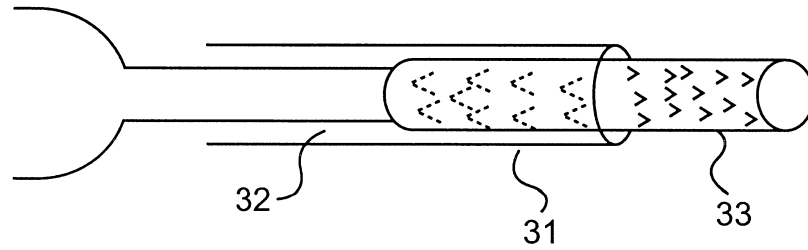


**Fig. 7D**

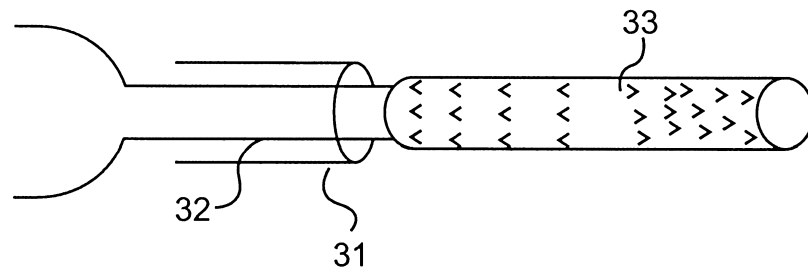


**Fig. 7E**

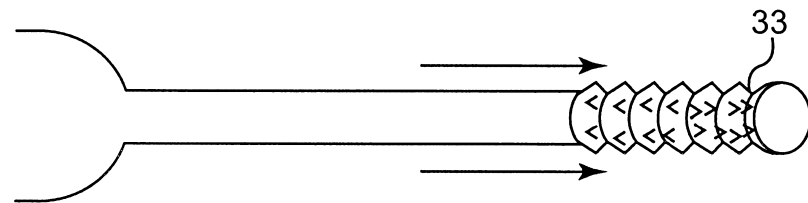
**Fig. 7F**



**Fig. 8A**

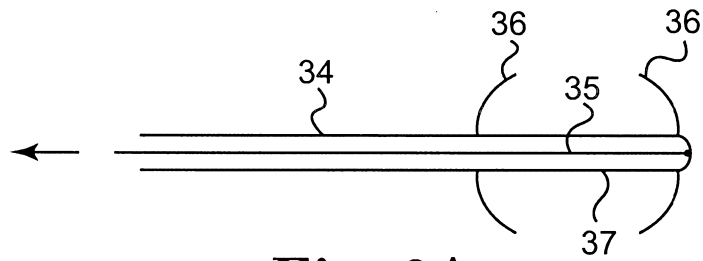


**Fig. 8B**

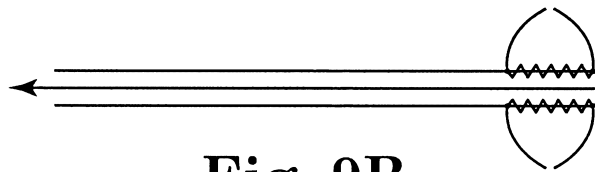


**Fig. 8C**

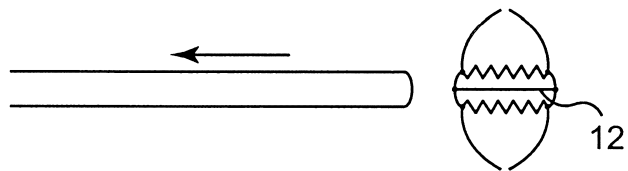
9/15



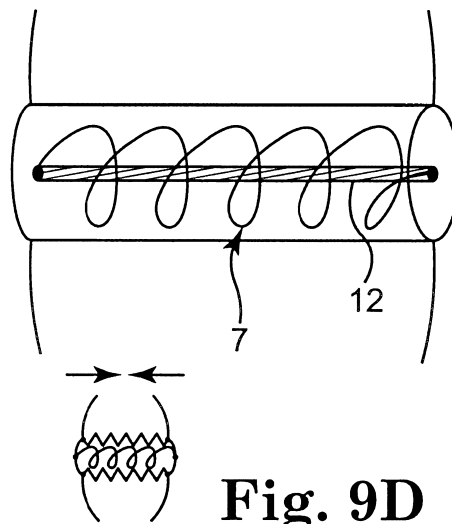
**Fig. 9A**



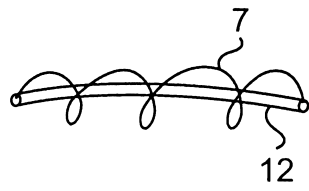
**Fig. 9B**



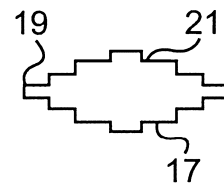
**Fig. 9C**



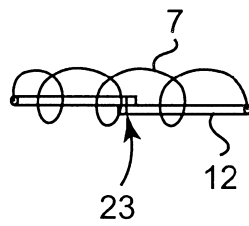
**Fig. 9D**



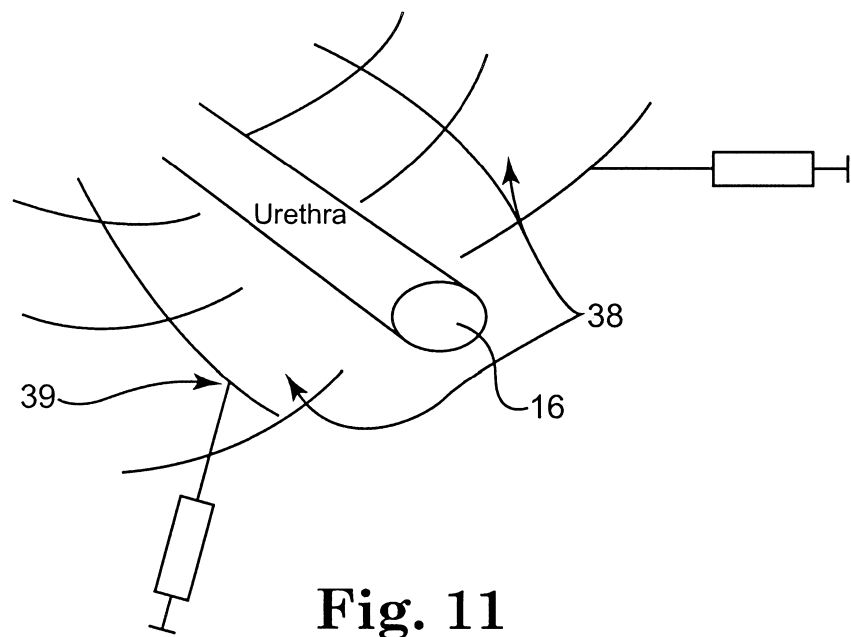
**Fig. 10A**



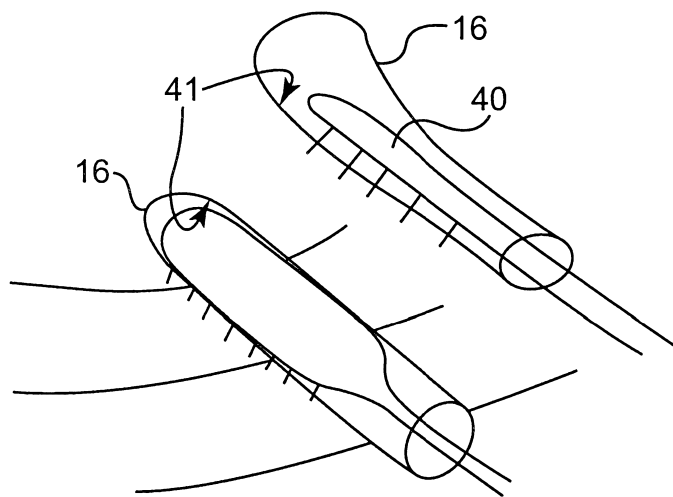
**Fig. 10B**



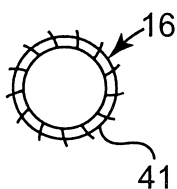
**Fig. 10C**



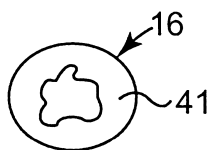
**Fig. 11**



**Fig. 12**

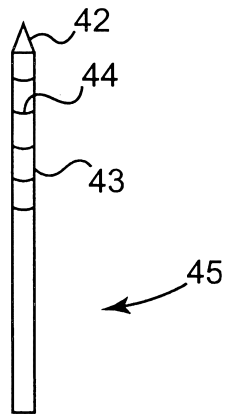


**Fig. 13A**

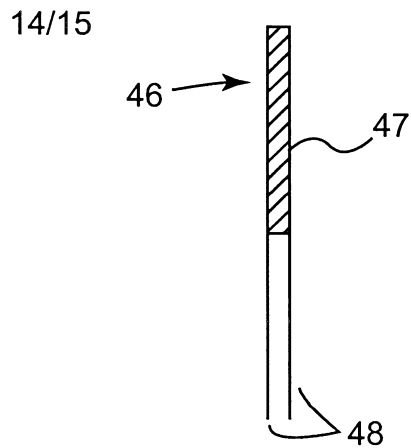


**Fig. 13B**

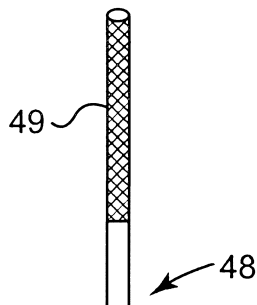




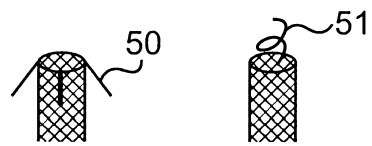
**Fig. 14**



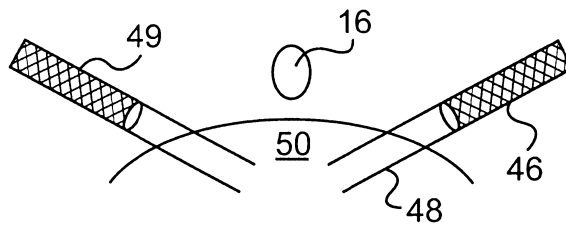
**Fig. 15**



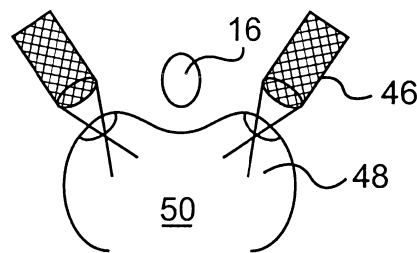
**Fig. 15A**



**Fig. 16**

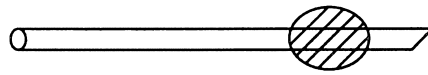


**Fig. 17**

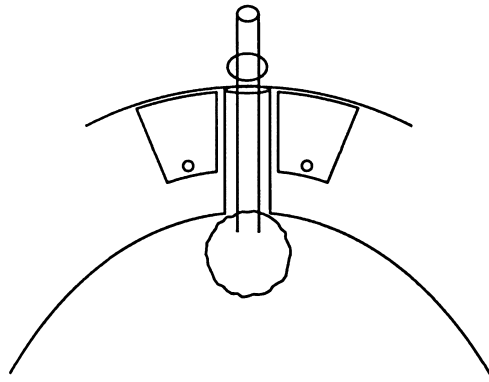


**Fig. 18**

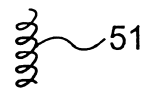
15/15



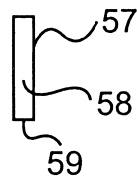
**Fig. 19**



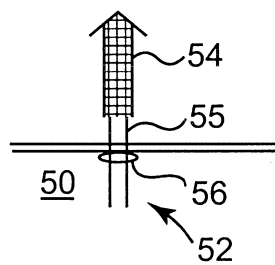
**Fig. 23**



**Fig. 20**



**Fig. 22**



**Fig. 21**