

L. R. NELSON.  
HOSE COUPLING.

APPLICATION FILED FEB. 27, 1904.

NO MODEL.

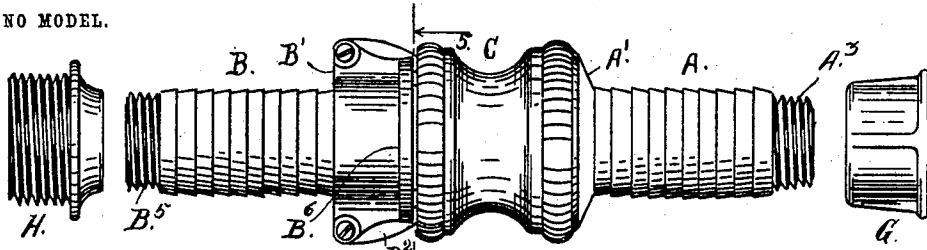

Fig. 1.

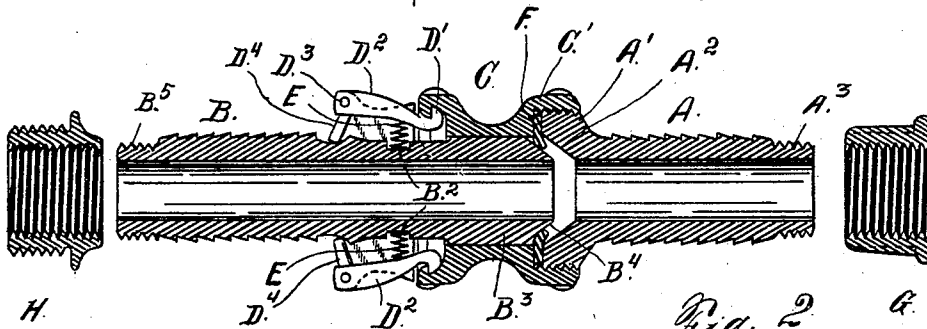

Fig. 2.

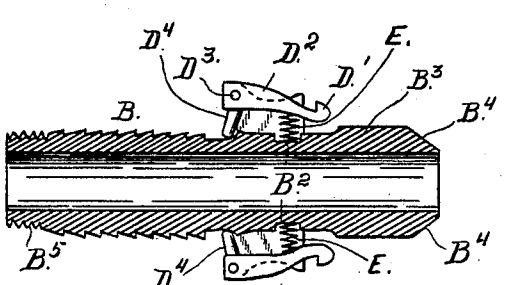

Fig. 3.

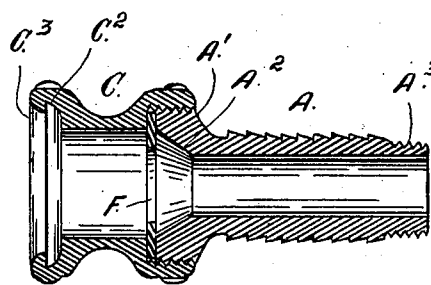

Fig. 4.

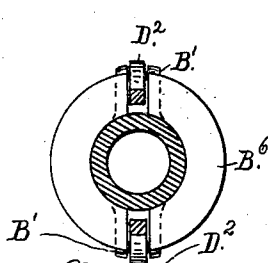

Fig. 5.

Witnesses  
*Otto C. Haddick*  
*Dena S. Nelson.*

*L. R. Nelson.*  
 Inventor  
*By A. J. S. M. W.*  
 Attorney

# UNITED STATES PATENT OFFICE.

LEWEN R. NELSON, OF BOULDER, COLORADO.

## HOSE-COUPLING.

SPECIFICATION forming part of Letters Patent No. 763,317, dated June 21, 1904.

Application filed February 27, 1904. Serial No. 195,692. (No model.)

*To all whom it may concern:*

Be it known that I, LEWEN R. NELSON, a citizen of the United States of America, residing at Boulder, in the county of Boulder and State of Colorado, have invented certain new and useful Improvements in Hose-Couplings; and I do declare the following to be a full, clear, and exact description of the invention, such as will enable others skilled in the art to which it appertains to make and use the same, reference being had to the accompanying drawings, and to the letters of reference marked thereon, which form a part of this specification.

My invention relates to improvements in hose-couplings and is adapted for use either with garden or fire hose or other conduits, as may be desired.

My object is to provide a device adapted to enable the user to quickly join or connect two sections of hose and at the same time to provide a device which shall be secure against accidental uncoupling and at the same time which shall efficiently perform the hose-coupling function, making a perfectly tight joint, whereby leaking is avoided. My improved device is believed to be quick, efficient, and thoroughly practicable in use.

Having stated the class to which my improvement belongs and outlined the functions it is intended to perform, I will proceed to describe the same in detail, reference being made to the accompanying drawings, in which is illustrated an embodiment thereof.

In the drawings, Figure 1 is a side elevation of my improved device shown in the coupled position. Fig. 2 is a longitudinal section of the same. Figs. 3 and 4 are sections of the two hose-coupling members detached. Fig. 5 is a section taken on the line 5-5, Fig. 1.

The same reference characters indicate the same parts in all the views.

Let A and B designate, respectively, the two parts of a hose-coupling to which the hose or rubber tube is applied, the two sections being roughened or corrugated in the usual manner. The part A is provided with an enlarged head A', exteriorly threaded to screw into the correspondingly interiorly threaded extremity C' of a coupling-sleeve C. The opposite extremity of this sleeve is pro-

vided with a circumferential groove C<sup>2</sup>, adapted to engage the inner extremities D' of a pair of locking-dogs or pawls D<sup>2</sup>, which are pivotally connected, as shown at D<sup>3</sup>, with laterally-projecting parts B' of the part B. Each part B' is bifurcated to receive the dog or pawl D<sup>2</sup>, the latter being normally held outwardly in the locking position by coil-springs E, seated in shallow recesses B<sup>2</sup>, formed in the part B. The dogs or pawls D<sup>2</sup> are rounded or beveled at their inner extremities to engage the rounded or beveled edge C<sup>3</sup> of the sleeve C, whereby as the free extremities of the dogs are brought into engagement with the part C<sup>3</sup> of the coupling-sleeve by an inward thrust the heads or holding extremities of the dogs will slip into the sleeve and engage the circumferential groove of the latter, thus locking the part B to the sleeve and quickly and efficiently performing the hose-coupling function. The coupling part B is provided with an extension B<sup>3</sup>, which projects inwardly beyond the locking-dogs, its inner extremity being beveled, as shown at B<sup>4</sup>. This beveled end of the coupling extension engages a plain washer F, whose inner periphery projects into the path of the extension B<sup>3</sup> and when engaged by the bevel forms a water-tight joint, whereby the water is prevented from escaping around the coupling-sleeve. The washer F is secured in place between the abutting extremity of the head A' and a shoulder formed on the coupling-sleeve at the inner extremity of its threaded part C'. The head A' of the coupling part A is also beveled, as shown at A<sup>2</sup>, the bevels A<sup>2</sup> and B<sup>4</sup> being substantially parallel, whereby the inner periphery of the washer F is allowed to turn slightly outwardly as the beveled end of the section B is brought into engagement therewith. The two bevels A<sup>2</sup> and B<sup>4</sup> leave an interior circumferential channel which the water enters to engagement with the packing-washer F. The force of the water acts automatically on this washer to form a tight joint in a manner that will be readily understood.

From the foregoing description the use and manipulation of my improved hose-coupling will be readily understood. When in use, the parts A and B will each be inserted in the

open extremity of one of the hose sections or parts to be coupled and secured thereto in the usual manner. These hose parts or sections are not illustrated in the drawings, but it may be assumed that they are of any suitable length.

At the right of Figs. 1 and 2 an interiorly-threaded sleeve G is illustrated. This sleeve adapted to be screwed upon the threaded nipple of the hydrant or hose provided with ordinary coupling, while the threaded extremity A<sup>3</sup> of the part A may be screwed into the sleeve above the hydrant-nipple. In this way the female member composed of the parts A and C may be connected with the hydrant in order to make a rapid coupling, assuming that the part B is connected with the length of hose to be attached to the hydrant. In this event it will only be necessary to move the part B against the sleeve C until the dogs D<sup>2</sup> have an engagement with the sleeve, as will be readily understood. At the left of Figs. 1 and 2 an interiorly and exteriorly threaded sleeve H is shown. The ordinary hose-nozzle or hose provided with ordinary coupling (not shown) may be screwed upon the exterior thread of this sleeve, while the coupling part B may be screwed into the interior thread of the sleeve. Assuming that the part B is left connected with the nozzle through the instrumentality of the sleeve H, the nozzle, together with the part B, may be rapidly connected with the piece of hose to which it is to be applied through the instrumentality of the locking-dogs, assuming that the part A of the coupling is connected with the outer extremity of the hose. The outer extremity of the part B is threaded, as shown at B<sup>5</sup>, to permit its attachment with the sleeve H. The use last described of my improved coupling may be said to be a special use and may be found advantageous by reason of the rapidity or quickness with which the coupling parts may be connected.

Attention is called to the fact that each dog D<sup>2</sup> is provided with an inwardly-projecting stop D<sup>4</sup>, adapted to limit the outward movement of the holding extremities D<sup>1</sup> when actuated by the springs B<sup>2</sup>. It is evident if it were not for the stops D<sup>4</sup> when the part B<sup>1</sup> was uncoupled from the sleeve C the springs B<sup>2</sup> acting on the dogs would throw them farther outwardly than would be desirable.

Assuming that the parts A and B are suitably attached to hose lengths or parts to be connected, it will be understood that it will only be necessary to bring the two parts A and B together, whereby the extremity B<sup>3</sup> of the male part B is caused to enter the adjacent opening of the female part A, the movement of the two parts being continued until the inner or holding extremities of the locking-dogs D<sup>2</sup> are caused to engage or take into a circumferential groove C<sup>2</sup> of the coupling-sleeve C. In this case it is assumed that the washer F has already been placed in position

in the coupling-sleeve C and that the part A is screwed into the said sleeve to engagement with the washer, whereby the latter is held securely in place.

The coupling part B may be provided adjacent the sleeve C with a flange B<sup>6</sup>, the same being slotted to receive the dogs D<sup>2</sup>, whose holding extremities D<sup>1</sup> protrude through the said flange. This flange forms a sort of guard to prevent dirt from entering the circumferential groove when the parts are assembled.

Having thus described my invention, what I claim is—

1. A hose-coupling consisting of two parts A and B adapted to be attached to the hose-sections to be connected; and an intermediate coupling-sleeve, the latter being interiorly threaded and shouldered at one extremity to receive an enlarged exteriorly-threaded head formed on the coupling part A, a washer located between the said coupling part and the shoulder of the sleeve and protruding into the channel of the latter; and spring-actuated locking-dogs mounted on the coupling part B and adapted to engage an interior circumferential groove formed in the extremity of the coupling-sleeve remote from the packing-washer, the part B having a guard-flange slotted to receive the locking-dogs and an extension projecting beyond the locking-dogs, its inner extremity being beveled to engage the packing-washer.

2. In a hose-coupling, the combination of a sleeve having an interior shoulder at one extremity and an interior circumferential groove at the other extremity, the shouldered end of the sleeve having an interiorly-threaded part projecting beyond the shoulder, a washer engaging the shoulder and extending into the channel of the sleeve, a coupling part having an enlarged head exteriorly threaded to engage the interior threads of the sleeve and whose inner extremity abuts against the washer when the parts are assembled, a male hose-coupling section having an extension adapted to enter the sleeve and whose interior extremity is beveled to engage the inner periphery of the said washer, the head of the first-named coupling part being beveled to form a narrow channel leading from the central waterway to the washer, and suitable locking devices mounted on the male member of the coupling and adapted to engage the interior circumferential groove of the coupling-sleeve, the said male member having a guard-flange located adjacent the coupling-sleeve and slotted to receive the locking devices.

3. In a hose-coupling, a female member formed of a sleeve having a shouldered interiorly-threaded extremity and a coupling part having an enlarged head screwed into the threaded extremity of the sleeve and having an abutting inner extremity opposed to the shoulder of the sleeve, a packing-washer inserted between the shoulder of the sleeve and

the abutting extremity of the coupling part, the said washer protruding into the channel of the sleeve; a male member adapted to enter the sleeve of the female member to engagement with the inner periphery of the packing-washer, the inner extremity of the male member and the coupling part of the female member being shaped to form a narrow water-channel leading from the central water-channel to the washer, and suitable locking devices mounted on the male member and engaging the sleeve of the female member, the said member having a guard-flange located adjacent the coupling-sleeve and slotted to receive the locking devices.

4. A hose-coupling consisting of a sleeve and two coupling parts one being screwed into the sleeve, and the other being provided with spring-actuated locking-dogs adapted to engage an interior circumferential groove formed in the sleeve, the said dogs being provided with interiorly-projecting stops.

5. A hose-coupling consisting of a sleeve and two coupling parts, one being screwed into the sleeve, and the other being provided with locking-dogs adapted to engage an interior circumferential groove formed in the sleeve, the part carrying the locking-dogs being provided with a guard-flange slotted to allow the dogs to protrude and occupying a position adjacent the extremity of the sleeve which the locking-dogs enter.

6. A hose-coupling comprising a male and a female member, the female member being provided at one extremity with an interior circumferential groove, locking-dogs mounted on the male member and adapted to enter one extremity of the sleeve and engage the interior groove thereof, the extremities of the dogs remote from their holding ends being provided with interiorly-projecting stops which limit the outward movement of their

holding extremities when released from the sleeve.

7. In a hose-coupling, the combination of a male and female member, the female member having a sleeve provided with an interior circumferential groove located near one extremity, the male member being provided with ears between which are pivotally mounted locking-dogs provided with inwardly-projecting stops, springs engaging the male member and acting on the dogs intermediate their extremities, the holding extremities of the dogs being hook-shaped and adapted to enter the sleeve and engage the circumferential groove of the latter.

8. A hose-coupling consisting of three members namely, two coupling members and an intermediate sleeve, one coupling member being screwed into the sleeve, a washer interposed between the last-named coupling member and a shoulder on the sleeve, the washer protruding into the central opening of the sleeve; the other or male coupling member being provided with locking-dogs whose holding extremities enter one end of the sleeve and engage a circumferential groove formed in the latter, the said dogs being pivotally mounted and provided with interiorly-projecting stops on one side of the pivot, and springs engaging the dogs on the opposite side of the pivot, the male member being provided with an extension projecting beyond the holding extremities of the dogs and having its inner extremities beveled and engaging the said washer, substantially as described.

In testimony whereof I affix my signature in presence of two witnesses.

LEWEN R. NELSON.

Witnesses:

PHILIP H. KEYSER,  
IRA D. SCOTT.