



(12) **United States Design Patent**
Badillo

(10) **Patent No.:** **US D906,546 S**
(45) **Date of Patent:** **** Dec. 29, 2020**

- (54) **VEHICLE LADDER**
- (71) Applicant: **Intelligent Designs 2000 Corp.**,
Aurora, CO (US)
- (72) Inventor: **Paul Badillo**, Littleton, CO (US)
- (73) Assignee: **INTELLIGENT DESIGNS 2000**
CORP., Aurora, CO (US)

3,603,431 A 9/1971 Nameche et al.
 D222,526 S 11/1971 Meier
 D241,614 S 9/1976 Wallace
 4,151,895 A 5/1979 Rasada, Jr. et al.
 4,239,139 A 12/1980 Bott
 4,249,683 A 2/1981 Park
 4,312,620 A 1/1982 Muschalek, Jr.
 (Continued)

- (**) Term: **15 Years**
- (21) Appl. No.: **29/731,987**
- (22) Filed: **Apr. 20, 2020**

Related U.S. Application Data

- (63) Continuation of application No. 29/589,364, filed on Dec. 30, 2016, now Pat. No. Des. 882,119.
- (51) **LOC (12) Cl.** **25-04**
- (52) **U.S. Cl.**
USPC **D25/64**
- (58) **Field of Classification Search**
USPC D12/203, 400, 408; D25/62, 63, 64, 65,
D25/66, 67, 68, 69
CPC E06C 1/36; E06C 5/04; E06C 5/24; B60R
3/005; B63B 27/14
See application file for complete search history.

References Cited

U.S. PATENT DOCUMENTS

2,227,873 A	1/1941	Bartsch
2,419,065 A	4/1947	Fowler
2,485,413 A	10/1949	Ross
D173,148 S	10/1954	Emmite
D176,238 S	11/1955	Wallace et al.
2,947,555 A	8/1960	Olsen
3,028,929 A	4/1962	Chubbs
3,058,607 A	10/1962	Kiley
3,387,754 A	6/1968	Sinkey
3,498,410 A	3/1970	Storch

OTHER PUBLICATIONS

“FJ Ladder,” BajaRack Adventure Equipment, 2 pages, first sale estimated in 2011 [retrieved from: <http://www.bajarack.com/ladder>].

(Continued)

Primary Examiner — Susan E Krakower
Assistant Examiner — Jerry Shiuan-Hua Hsu
(74) *Attorney, Agent, or Firm* — Sheridan Ross P.C.

(57) **CLAIM**

The ornamental design for a vehicle ladder, as shown and described.

DESCRIPTION

FIG. 1 is a front perspective view of the vehicle ladder, showing my new design;
FIG. 2 is a front elevation view thereof;
FIG. 3 is a rear elevation view thereof;
FIG. 4 is a right elevation view thereof;
FIG. 5 is a left elevation view thereof;
FIG. 6 is a top plan view thereof;
FIG. 7 is a bottom plan view thereof; and,
FIG. 8 is a front elevation view thereof shown in a condition of use.
The broken lines on the ladder depict portions of the vehicle ladder that form no part of the claimed design. The broken lines in FIG. 8 showing a vehicle, illustrate environmental structure that forms no part of the claimed design.

1 Claim, 7 Drawing Sheets

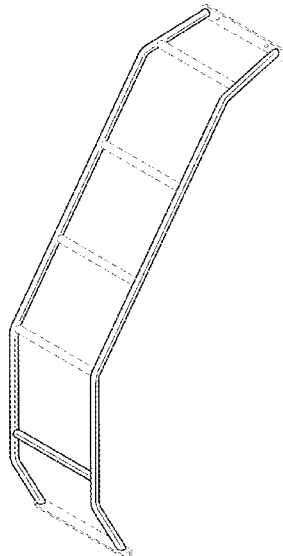

(56)

References Cited

U.S. PATENT DOCUMENTS

4,320,816	A	3/1982	Callahan	8,157,229	B2	4/2012	Palermo	
4,431,082	A	2/1984	Bott	8,261,880	B1	9/2012	Hop	
4,716,988	A	1/1988	Graffy	8,496,146	B2	7/2013	Badillo	
4,719,989	A	1/1988	Ritten	8,585,107	B2	11/2013	Kekich, Jr. et al.	
4,825,975	A	5/1989	Symes	8,602,162	B2	12/2013	Dondurur et al.	
4,831,808	A	5/1989	Wynar	D710,030	S	7/2014	Fitzgerald et al.	
D309,560	S	7/1990	Warlick	9,345,923	B2	5/2016	Haggard et al.	
4,947,961	A	8/1990	Dudley	D759,841	S *	6/2016	Badillo	D25/64
5,039,119	A	8/1991	Baughman	D770,962	S	11/2016	Badillo	
5,131,780	A	7/1992	Love	9,527,712	B1	12/2016	Pigg et al.	
5,228,739	A	7/1993	Love	D812,777	S *	3/2018	Ma	D25/64
D346,355	S	4/1994	Weger, Jr. et al.	9,945,179	B1 *	4/2018	Joldersma	E06C 5/24
D346,994	S	5/1994	Weger, Jr. et al.	D822,851	S *	7/2018	Conner	D25/64
D359,134	S	6/1995	Toews	10,030,446	B2	7/2018	Badillo	
D392,178	S	3/1998	Hirano	D832,760	S *	11/2018	Annett	D12/203
5,765,902	A	6/1998	Love	D845,853	S *	4/2019	Annett	D12/203
D410,374	S	6/1999	Meurer	D882,119	S *	4/2020	Badillo	D25/64
6,003,633	A	12/1999	Rolson	2003/0020253	A1	1/2003	Bosman et al.	
D423,328	S	4/2000	Burrows	2004/0069566	A1 *	4/2004	Bareket	E06C 5/04 182/97
6,116,378	A	9/2000	Barrow	2005/0039983	A1 *	2/2005	Tombarello	B63B 27/14 182/93
D442,289	S	5/2001	Ziaylek et al.	2005/0082326	A1	4/2005	Badillo	
6,231,093	B1	5/2001	Storer	2005/0098595	A1	5/2005	Smith et al.	
6,270,301	B1	8/2001	Dunlop	2006/0108179	A1 *	5/2006	Sieb	B60R 3/005 182/127
6,378,654	B1	4/2002	Ziaylek, Jr. et al.	2006/0124394	A1	6/2006	Bracken	
6,409,275	B1	6/2002	Gerding	2006/0191967	A1	8/2006	Smith et al.	
6,565,048	B1	5/2003	Meyer	2008/0277199	A1	11/2008	Castonguay	
D479,884	S	9/2003	Berryman	2011/0132252	A1	6/2011	Kaye	
D490,163	S	5/2004	Thurston	2015/0252618	A1	9/2015	Levi	
6,739,349	B2	5/2004	Kastenschmid et al.	2016/0159437	A1	6/2016	Pappas et al.	
6,948,588	B1	9/2005	Chustak	2017/0050571	A1 *	2/2017	Badillo	E06C 5/24
D512,783	S *	12/2005	Badillo	2018/0044985	A1 *	2/2018	Orscheln	E06C 5/02
7,025,712	B2	4/2006	Parrilla	2018/0201195	A1 *	7/2018	Downing	E06C 5/04
7,066,299	B1	6/2006	Fleming	2018/0328109	A1	11/2018	Badillo	
D538,734	S	3/2007	Reimitz	2019/0351832	A1	11/2019	Fuller et al.	
D547,641	S	7/2007	Jueneman					
7,244,090	B2	7/2007	Wooten et al.					
7,249,927	B2	7/2007	Wooten et al.					
D549,838	S *	8/2007	Badillo					
D601,719	S	10/2009	Gibson					
7,789,359	B2	9/2010	Chopp, Jr. et al.					
7,819,225	B2	10/2010	Smith					
7,874,966	B2	1/2011	Parrilla					
D657,054	S	4/2012	Bacon					

OTHER PUBLICATIONS

Official Action for U.S. Appl. No. 29/589,364, dated Sep. 30, 2019 6 pages.

Notice of Allowance for U.S. Appl. No. 29/589,364, dated Dec. 20, 2019 6 pages.

* cited by examiner

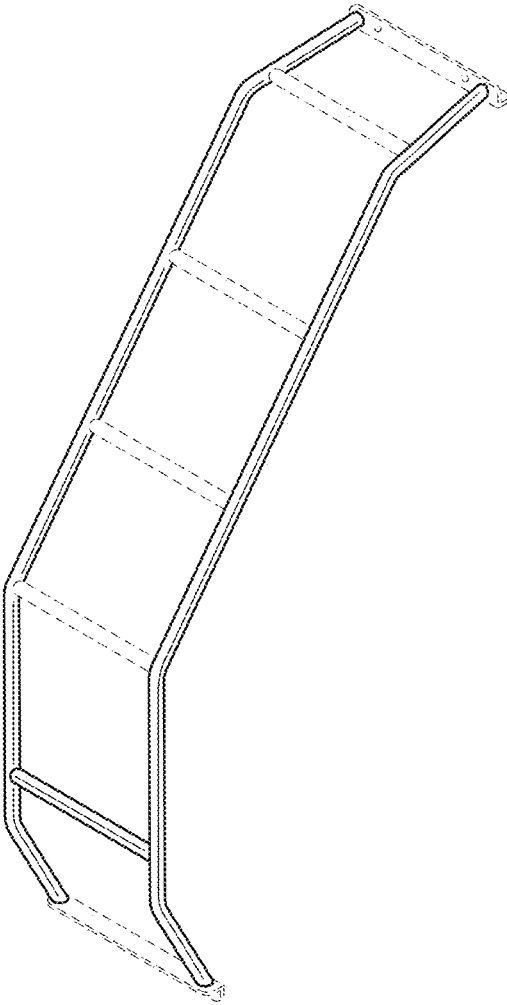

FIG.1

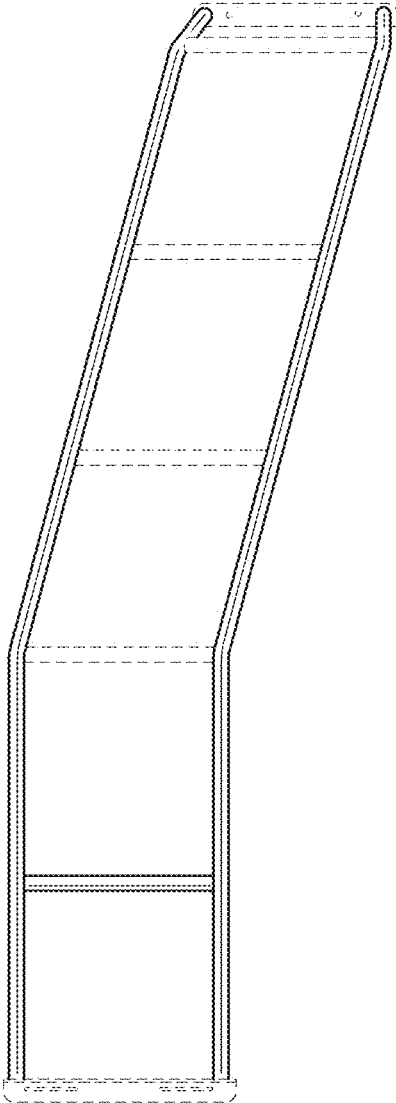

FIG.2

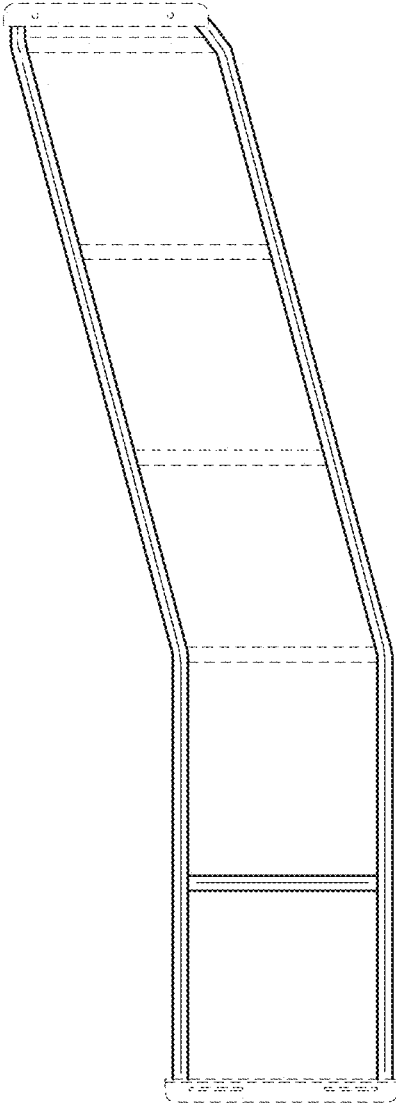

FIG.3

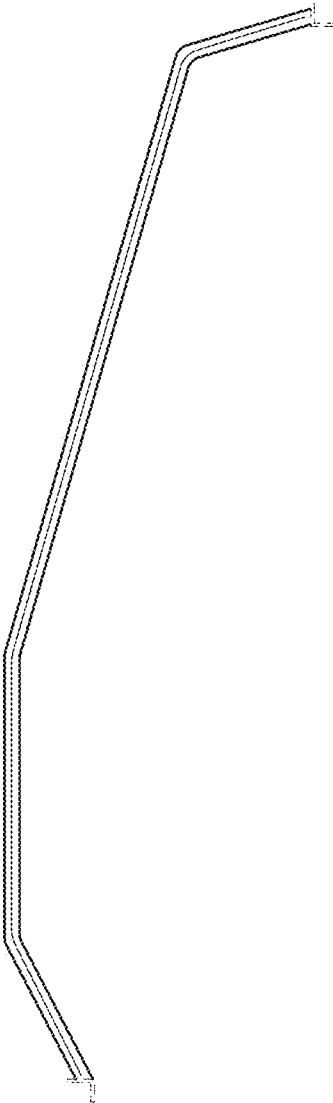

FIG.4

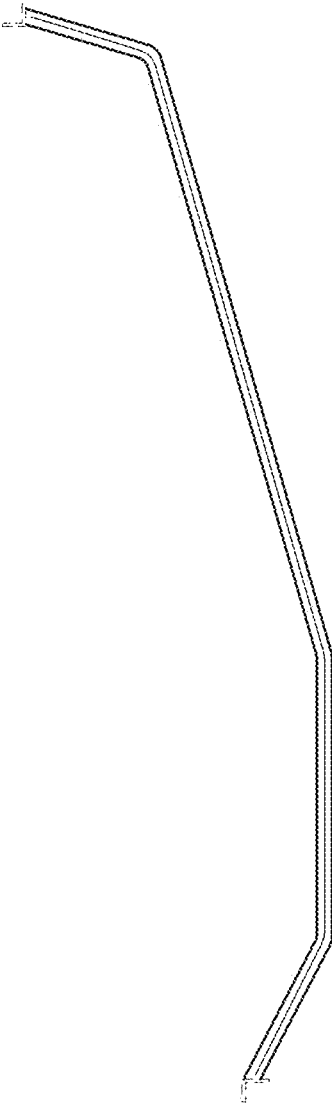

FIG.5

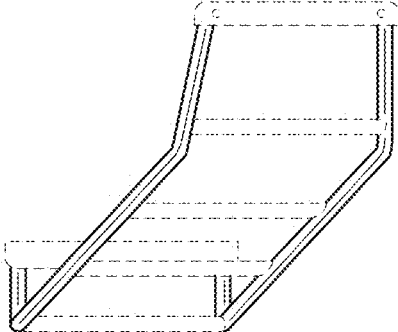

FIG. 6

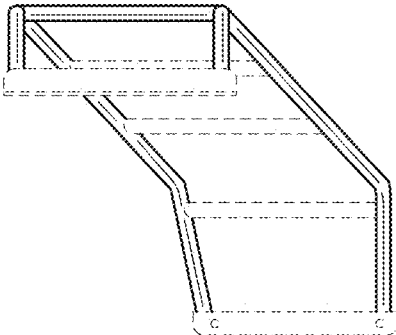

FIG. 7

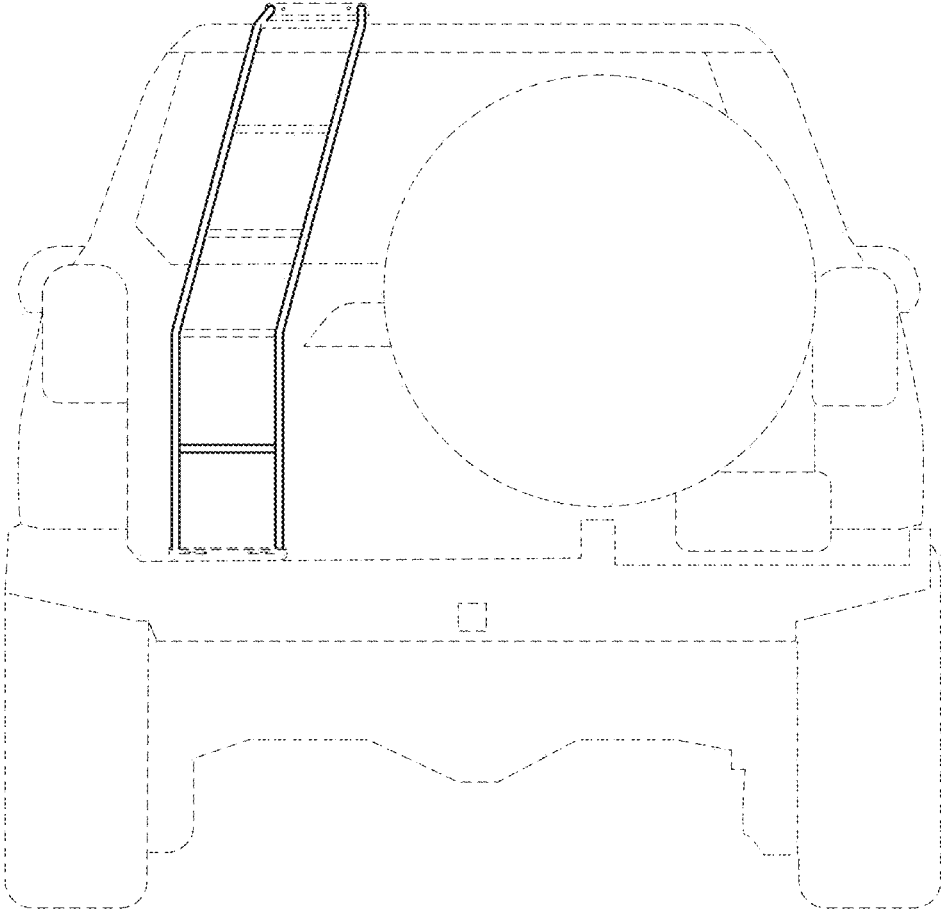

FIG.8