

(No Model.)

H. FLEINER.  
SIPHON.

No. 523,739.

Patented July 31, 1894.

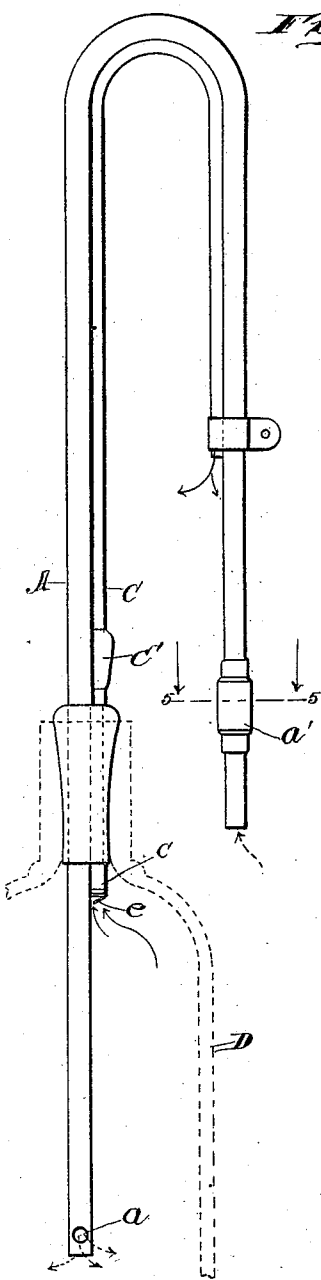

Fig. 1.

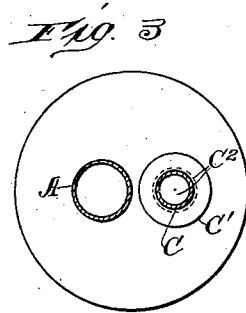

Fig. 3.

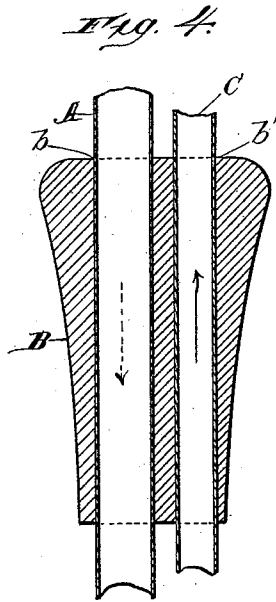

Fig. 4.

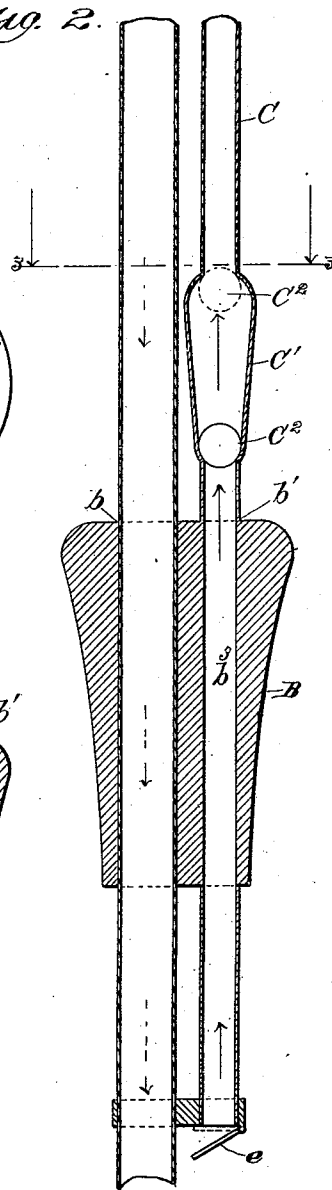
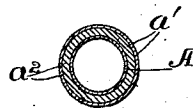

Fig. 2.

Fig. 5.



Witnesses:

Chas. E. Gordon.  
S. A. Duggan

Inventor:

Hermann Fleiner.

By Chas. C. Gillman

Att'y

# UNITED STATES PATENT OFFICE.

HERMANN FLEINER, OF CHICAGO, ILLINOIS.

## SIPHON.

SPECIFICATION forming part of Letters Patent No. 523,739, dated July 31, 1894.

Application filed April 10, 1893. Serial No. 469,729. (No model.)

*To all whom it may concern:*

Be it known that I, HERMANN FLEINER, a subject of the Emperor of Germany, residing at Chicago, in the county of Cook and State of Illinois, have invented certain new and useful Improvements in Siphons, of which the following is a specification.

This invention relates to improvements in devices for transferring liquids from a cask or barrel to another vessel, and consists in certain peculiarities of the construction, novel arrangement, and operation of the various parts thereof, as will be hereinafter more fully set forth and specifically claimed.

The objects of my invention are first, to provide a simple and inexpensive means for automatically transferring liquids from one cask to another, or of filling bottles, jugs, and flasks or smaller vessels from a cask, barrel or larger receptacle, in such a manner as to prevent the overflow of the smaller vessel, thus preventing waste of the liquid; and second, such a device which is so constructed as to be adjustable or adapted to bottles or vessels of various sizes and by reason of its formation will keep the end or portion inserted in the cask from which the liquid is withdrawn, at or near the bottom thereof.

In order to enable others skilled in the art to which my invention pertains to make and use the same, I will now proceed to describe it, referring to the accompanying drawings, in which—

Figure 1, is a view in side elevation of one construction of my siphon, and a portion of a bottle or flask, showing the manner of securing the siphon therein and filling the flask or vessel. Fig. 2, is a longitudinal sectional view of the stopper, liquid-tube, and air-pipe, showing the latter provided with valves or cut-offs to prevent over-flow. Fig. 3, is a plan view thereof, taken on line 3, 3, of Fig. 2. Fig. 4, is a vertical sectional view of a modification in the construction of the stopper and its pipes, or tubes; and Fig. 5, is a cross sectional view of the fluid-tube, taken on line 5, 5, of Fig. 1.

Similar letters refer to like parts throughout the different views of the drawings.

A, represents the fluid-tube, which may be made of any suitable size, length, form, and ma-

terial, but preferably of rubber or some other flexible substance. The lower end of this tube or the end thereof to be inserted within the smaller vessel, or the vessel to be filled from another one, is preferably provided with perforations *a*, through which the liquid may flow, when the end of the tube rests on the bottom of the vessel. As shown in the drawings, this tube is passed through the stopper B, which is provided with a longitudinal opening *b*, for the reception and retention of said tube. This opening is preferably placed somewhat out of the center of the stopper, as is illustrated, and near it and vertically and longitudinally through the stopper, is formed another opening *b'*, through which is passed another tube C, which is for the passage of air. The tube C, extends but slightly through the bottom of the stopper, as shown at *c*, and may be made integral with the tube A, as shown in Fig. 1, (but the tubes form separate channels) or they may be made separate and distinct, as shown in Figs. 2, 3, and 4, of the drawings.

Near its upper end or the end to be inserted into the cask, from which the liquid is to be withdrawn, the tube A, may be provided with a weight or enlargement *a'*, which will cause the same to sink to the bottom of the vessel, as is apparent. This weight may be tubular in form, as shown in Fig. 5, and may consist of a piece of lead or other heavy substance, and may also be provided with an outer covering *a''*, the tube A, forming the inner covering thereof, and protecting the same from corrosion.

The tubes A, and C, may be rigidly secured to the stopper B, or may be formed integral therewith, but in order to render my device adjustable or adaptable to bottles or casks of various sizes and heights, I may form the stopper with two openings *b*, and *b'*, for the reception and retention of the tubes A, and C, respectively, as is seen in Fig. 4, which construction will allow of the stopper being moved up and down on said tubes or pipes, but I prefer the construction shown in Fig. 2, in which the fluid-pipe A, is passed loosely through the opening *b*, and the air-pipe C, is made integral with the stopper, having a channel *b''*, therethrough. As the air-pipe C, extends a short distance only, through the

lower end of the stopper, it is obvious that it is not absolutely necessary for it to be adjustably secured within the stopper.

As it may sometimes occur that the upper  
5 end of the air-tube C, or the end next the induction end of the fluid-tube will sometimes be below the level of the fluid within the cask from which it is being withdrawn, and as under such circumstances the liquid would rise  
10 from the bottle D, or other vessel being filled, through the air-tube, and over-flow at its so located upper portion, it becomes necessary to provide said air-tube with a valve or cut-off to prevent such an occurrence, and in order  
15 to accomplish this I may hinge to the lower end of the air-tube a door or plate e, which may be made of aluminum or other light material, which when at its normal position will hang angularly or in an inclined  
20 position, as shown in the drawings, and as the fluid or liquid rises within the bottle, it will lift said plate which floats on the surface thereof, until it closes the lower aperture of the air-pipe, thus shutting off the passage,  
25 and preventing waste of the liquid.

Instead of employing the aforesaid plate or hinged door, I may form the tube C, with an enlargement or chamber C', which is preferably  
30 within said chamber a float or ball C<sup>2</sup>, which is also made of light material, and will be forced to the position indicated by dotted lines in Fig. 2, by the pressure of the liquid and air, thus closing the channel for escape.

It will be observed that the chamber C', is  
35 slightly funnel-shaped or tapers toward its bottom, and is thus formed for the reason, that as the air in the bottle or vessel being filled, will be somewhat compressed, and by  
40 reason of its tendency to expand or escape will cause the ball C<sup>2</sup>, to rise from its normal position, when the air may escape through the space between the periphery of the ball  
45 the liquid should rise in the air-tube, the ball

would float on the surface thereof until it reaches the top of the chamber, which is contracted as shown, and would stop the channel or opening.

By reference to Figs. 1, and 2, it will be seen  
50 that the plate or hinged door e, hangs in an inclined or angular position, and this is for the reason that in such a position the liquid as it rises in the vessel will contact with the broad or flat surface thereof and cause it to  
55 rise, while if it hung in a vertical position it would contact only with the edge of said plate, and the operation of closing the air-tube would not be attained. This angular or inclined position of the said door may be at-  
60 tained in any desired manner.

It is apparent that I may use either the hinged door as a cut-off or valve, or the ball or float, or both of them, or when the vessel  
65 from which the liquid is withdrawn is placed sufficiently above the receptacle being filled, or when the upper end of the air-pipe is above the level of the liquid in the vessel from which it is being withdrawn, that I may dispense  
70 with both cut-offs or valves.

In the drawings the arrows in dotted lines indicate the direction of the flow of the liquid, and those in continuous lines show the direction of the passage of the air.

Having thus fully described my invention, 75 what I claim as new, and desire to secure by Letters Patent, is—

In a siphon, the combination of the tube A, for the liquid, having one of its ends perforated and its other weighted, with the tube  
80 C, having the tapering chamber C', provided with the float C<sup>2</sup>, and the hinged and angularly depending door e, the stopper B, having an opening for the tube A, and a channel for the tube or pipe C, made integral therewith,  
85 substantially as described.

HERMANN FLEINER.

Witnesses:

CHAS. C. TILLMAN,  
E. A. DUGGAN.