

(19)  
(12)

(KR)  
(B1)

(51) 。 Int. Cl. <sup>6</sup>  
G11B 5/127

(45)  
(11)  
(24)

2002 06 20  
10 - 0320709  
2002 01 02

(21) 10 - 1994 - 0009093  
(22) 1994 04 28

(65) 1994 - 0024673  
(43) 1994 11 18

(30) 93 - 124,685 1993 04 30 (JP)

(73) 가 가  
가 가 6 7 35

(72) 가  
가 가 6 7 35 가 가  
가 가 6 7 35 가 가  
가 가 6 7 35 가 가  
가 가 6 7 35 가 가  
가 가 6 7 35 가 가  
가 가 6 7 35 가 가  
가 가 6 7 35 가 가

(74)  
:

(54)

1 가 , (殘部) 가 . ,  
(電磁) {100} 가 , {100} . ,

1

1 1

2 1

3

4

5 1

6

7

8 1

9 1

10 2

11 3

12

13

\*

(1),(2),(41),(42),(61),(62) : , (13),(14),(43),(44),(73),(74) : , (15), (16), (45),  
(46), (75), (76) : , (47),(48),(77),(78) : , g 1,92,93,94,95,96;

VTR

/

VTR

/

82) 12 1 (81), (82) 97 (가) 98 (가) (81), (83), (84) (81), (82) 97 (가)

(83), (84) (87)가 (81), (82) (89), (90), 가 (91), (92) (81), (82) (89), (90)

(面方位) 가 (電磁)

Mn - Zn {211}, {111}, {110} J 가 {110}, {100}, {110}

{211} J , J 13 , J 가

VHS

J

가

(殘部)

1

가

{100}

{100}

{100}

{100}

{100}

가

가

{100}

가

VTR /

VTR / (高抗磁力) 가 가

( , MIG ) ( , TSS )

MIG

TSS

MIG TSS 가 2 3

2

3

1

가

1 1  $g_1$  ( ),  $g_2$  ( ) (1),(2)가 가 (1),

(2)  $g_1$  (3),(4),  $g_2$  (5),(6)

(1),(2) (3),(4) (5),(6) (7),(8)가

(1),(2) (9),(10), 가 (11),(12)

(9),(10)

(1),(2) (13),(14) {100}

가 (15),(16)

{100}

2 (面方位)

(13),(17) (15),(18)

(19) (19) (19a) (競面)가

(13),(17) (13a),(17a) {100} (13b),(17b) {100}

3 (19) Tw  
(20) 가 Tw 가

4 (19) (20) (9),(22)  
(21),(23) (9),(22) 가 (21),(23)  
(19) (20), (9),(22), (21),(23)  
(24),(26) (25),(27)

(19) 5 가  
(28) (19) (28) (24),(29),  
(25),(30), (26),(31), (27),(32)

(19),(28) ( )  
(19),(28) 6 (34) (20),(33)  
가

3a) (34) 7 (35) (1  
(11),(12)  
1 가  
가

가 8 8mm VTR  
8  
{100} 8 450  
4

가 , 가 , 가  
 , 가  
 , A<sub>1</sub>가 , A<sub>2</sub>가  
 , A<sub>3</sub>가 , A<sub>4</sub>가 , 9  
 , 가 ,  
 {100} ,  
 가 , ,

2

, TSS  
 10 g<sub>3</sub>( ), g<sub>4</sub>( )  
 (41),(42)가 , (41),(42)  
 (43a),(44a) , Fe - Al - Si  
 (47),(48) , 1 (41),(42) SiO<sub>2</sub>  
 (47),(48) 가 g<sub>3</sub>,g<sub>4</sub>  
 (47),(48) (43b), (44b)  
 (49),(50),(51),(52)가  
 (53)

, 가 (41),(42) (43),(44)  
 , 가 (45),(46) , {100} ,  
 {100}  
 , 1  
 , 1

, , ,  
 , , ,  
 {100} , {100} , 가 ,  
 , 가 , ,

3

, MIG ,

$11$   
 $1$  (61),(62)가  $g_5$ ( ) ,  $g_6$ ( )  
 (61),(62) ,  $g_5$  (63),(64),  $g_6$   
 (65),(66) , (69),(70)  
 (61),(62) (77),(78)  
 (63),(64) , (65),(66) (67),(68)가 , (61),(6  
 2) (61),(62) 가 (71),(72) , (69),(70)  
 , (61),(62) 가 (73),(74)  
 {100} , {100} (75),(76)  
 , 1 1  
 , 2  
 가 , {100} , {100}  
 가 ,

(57)

1.

가 ,

{100}

2.

1 ,

3.

1 ,

4.

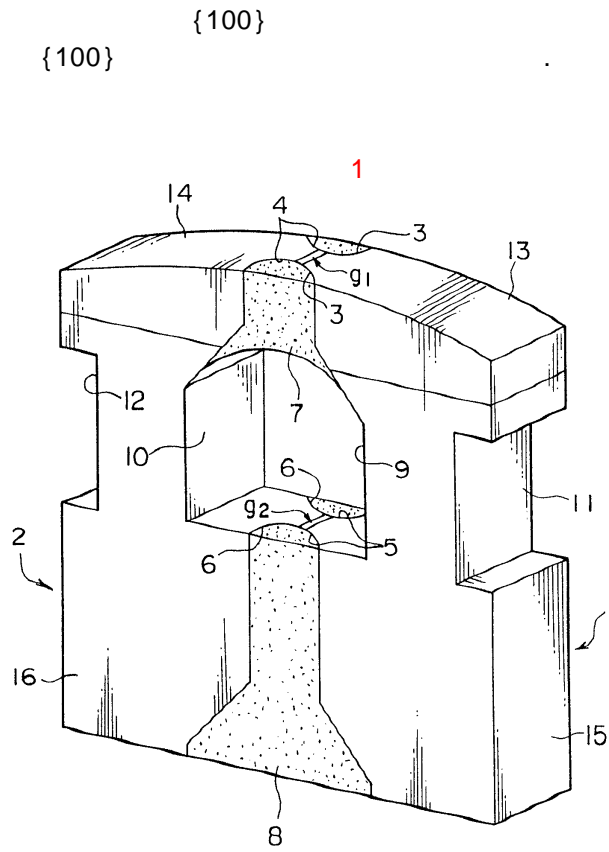



2

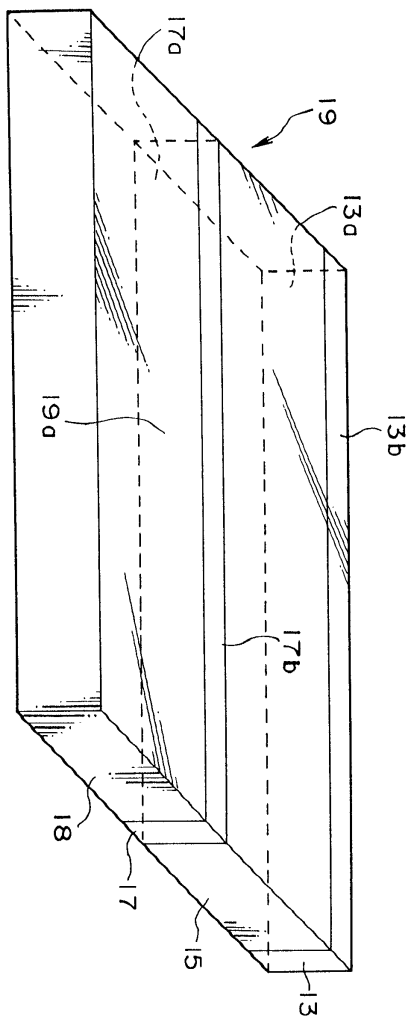

3

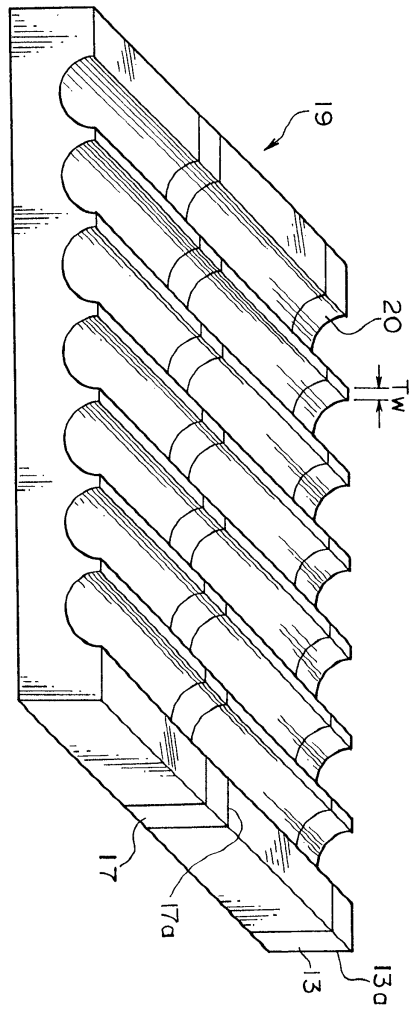

4

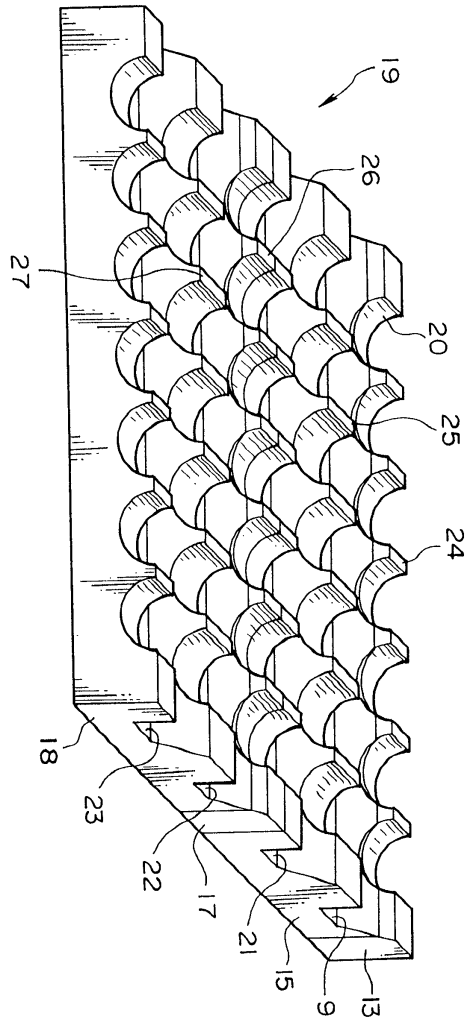

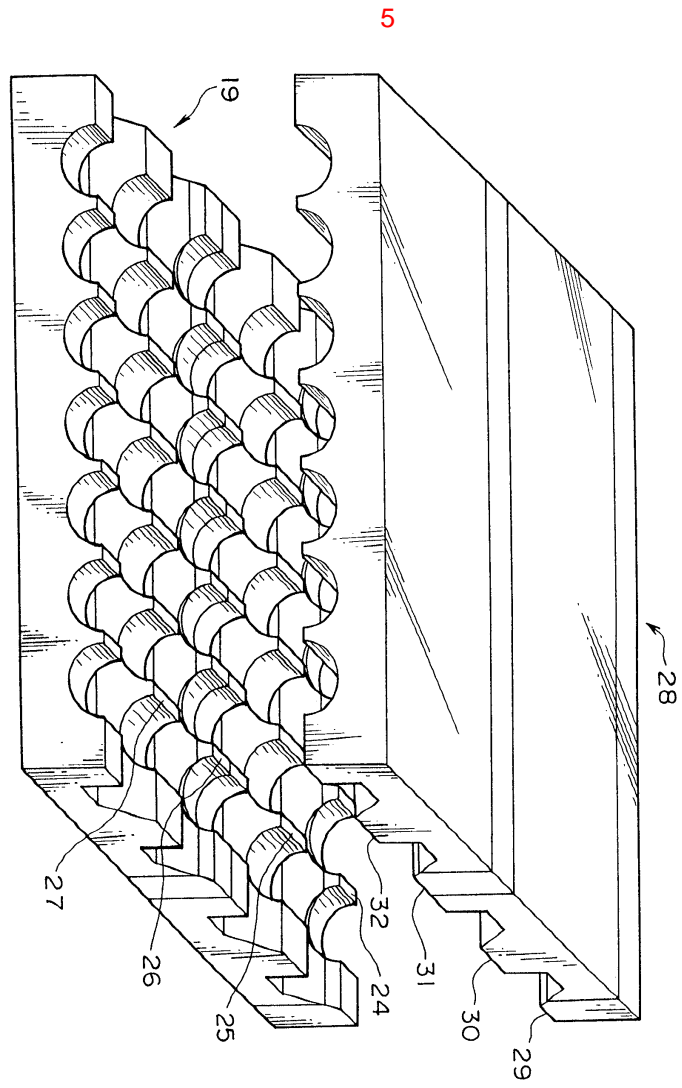

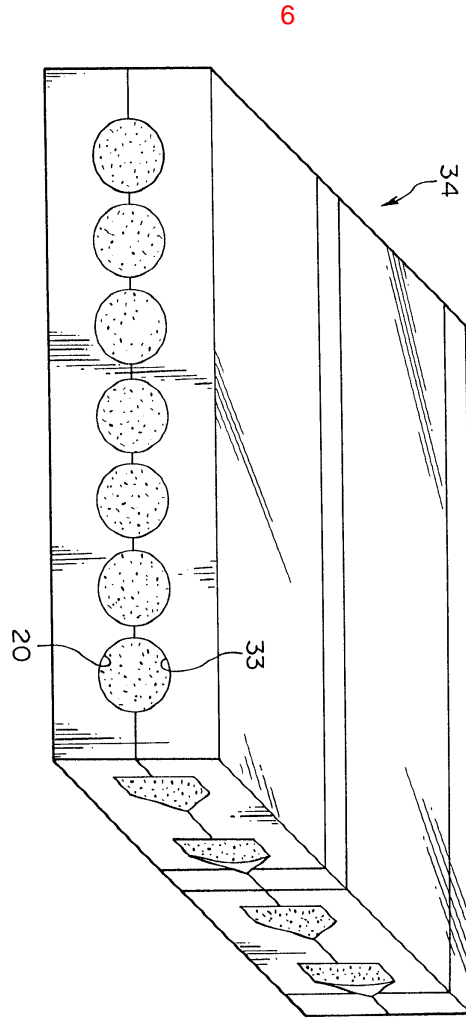

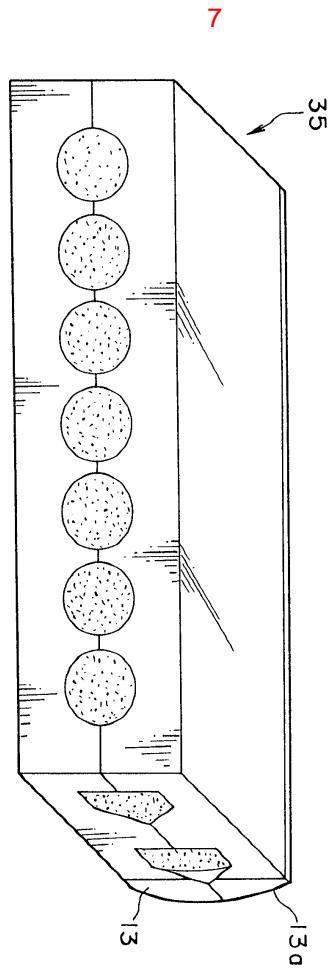

8

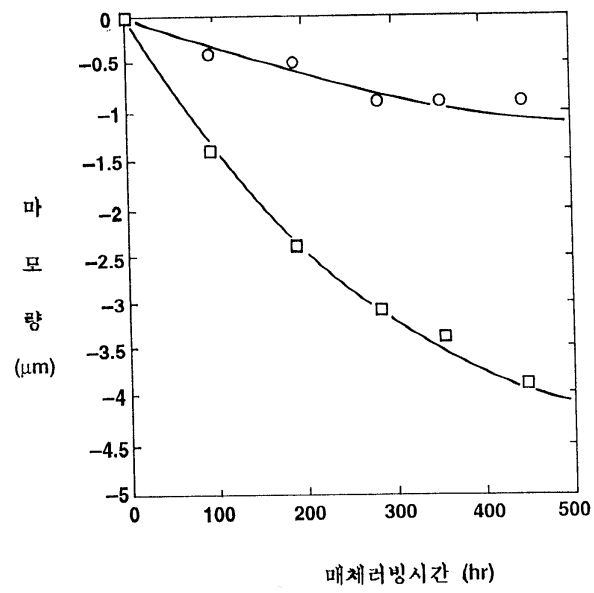

9

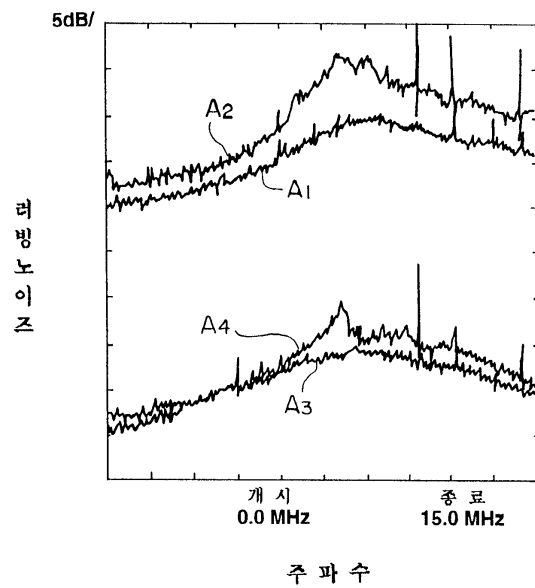

10

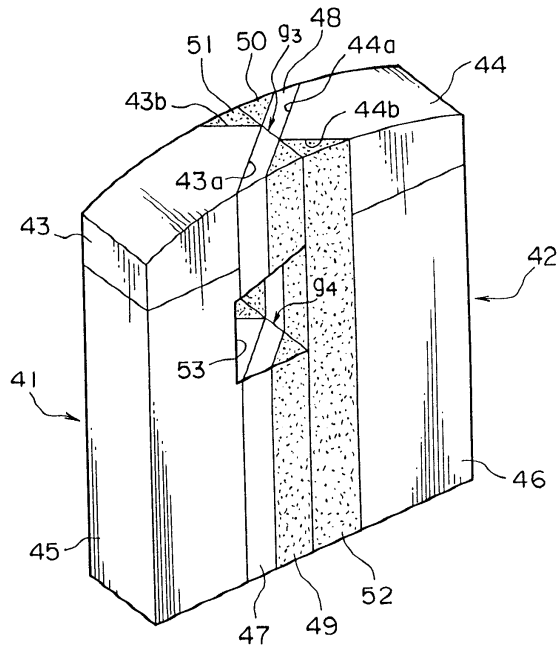

11

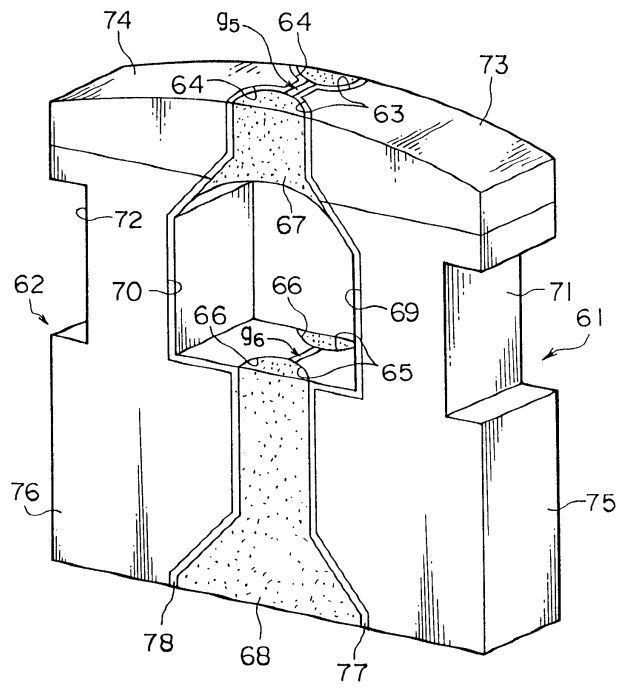



12

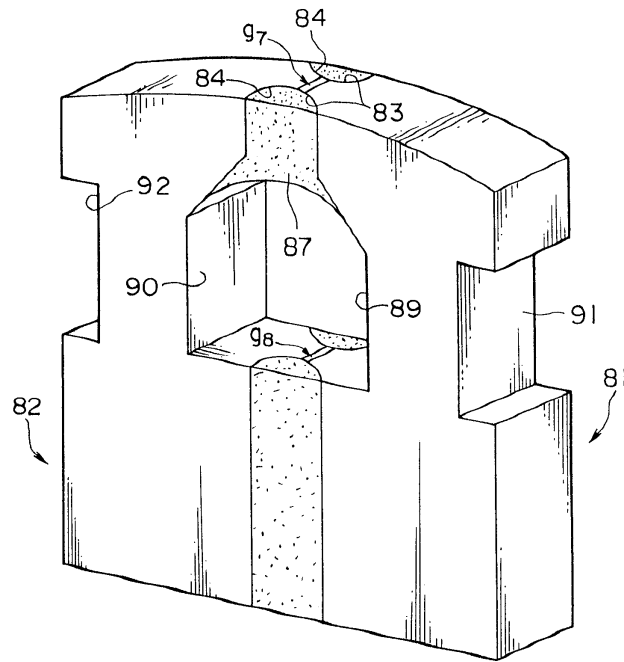

13

