

(19) World Intellectual Property Organization  
International Bureau



(43) International Publication Date  
28 December 2000 (28.12.2000)

PCT

(10) International Publication Number  
**WO 00/78384 A1**

- (51) International Patent Classification<sup>7</sup>: **A61M 16/06**
- (21) International Application Number: PCT/AU00/00097
- (22) International Filing Date: 11 February 2000 (11.02.2000)
- (25) Filing Language: English
- (26) Publication Language: English
- (30) Priority Data:  
PQ 1040 18 June 1999 (18.06.1999) AU
- (71) Applicant (for all designated States except US): **RESMED LIMITED** [AU/AU]; Legal Dept., 97 Waterloo Road, North Ryde, NSW 2113 (AU).
- (72) Inventors; and
- (75) Inventors/Applicants (for US only): **KWOK, Philip, Rodney** [AU/AU]; 15 Davies Street, Chatswood, NSW 2067 (AU). **GUNARATNAM, Michael, Kassipillai** [AU/AU]; 3 Keiley Street, Marsfield, NSW 2122 (AU). **LITHGOW, Perry, David** [AU/AU]; 9/33 Khartoum Road, North Ryde, NSW 2113 (AU). **HARRISON, Jonathan, Paul** [NZ/AU]; 86 Marriott Street, Redfern, NSW 2016 (AU). **LISTON, Jonathan, Lee** [AU/AU]; 36 Zamia Street, Redfern, NSW 2016 (AU). **MATCHETT, Robert, Stephen** [AU/AU]; 1 Melrose Street, Mosman, NSW 2088 (AU). **STYLES, Robert, Edward** [AU/AU]; 35 Linksley Avenue, Glenhaven, NSW 2156 (AU).
- (74) Agent: **SPRUSON & FERGUSON**; G.P.O. Box 3898, Sydney, NSW 2001 (AU).
- (81) Designated States (national): AE, AL, AM, AT, AU, AZ, BA, BB, BG, BR, BY, CA, CH, CN, CR, CU, CZ, DE, DK, DM, EE, ES, FI, GB, GD, GE, GH, GM, HR, HU, ID, IL, IN, IS, JP, KE, KG, KP, KR, KZ, LC, LK, LR, LS, LT, LU, LV, MA, MD, MG, MK, MN, MW, MX, NO, NZ, PL, PT, RO, RU, SD, SE, SG, SI, SK, SL, TJ, TM, TR, TT, TZ, UA, UG, US, UZ, VN, YU, ZA, ZW.

[Continued on next page]

(54) Title: FOREHEAD SUPPORT FOR FACIAL MASK

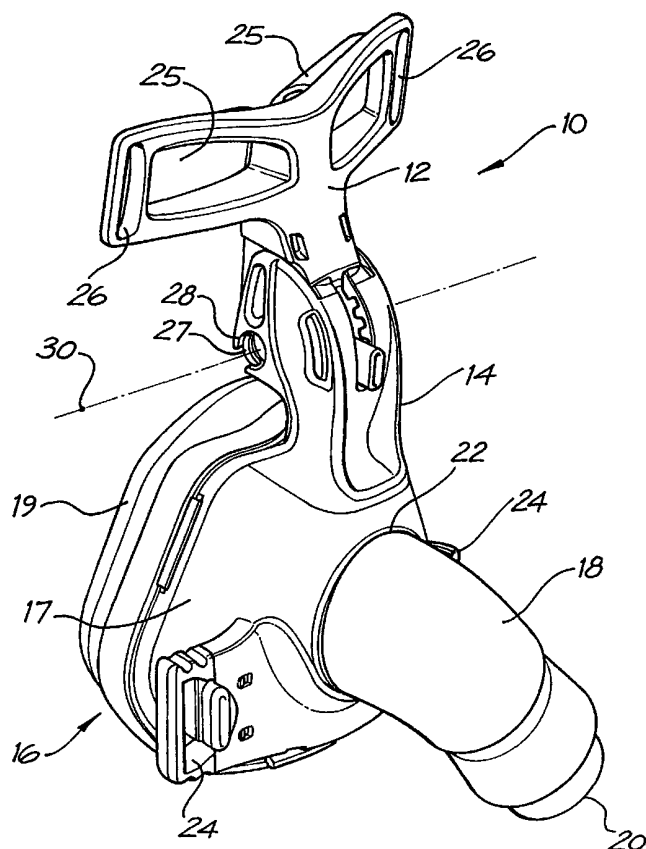

(57) Abstract: A forehead support (10) is disclosed that is adapted to be secured to a respiratory mask (16). The forehead support (10) including a joining member (14) for securing to the mask (16) and a cushion frame (12) pivotally mounted to the joining member (14). The cushion frame (12) is adapted to locate one or more forehead cushions (25). The cushion frame (12) is also adapted to pivot relative to the joining member (14). The cushion frame (12) is also selectively lockable at two or more predetermined angular positions relative to the joining member (14). A respiratory mask assembly comprising a respiratory mask (16) and a forehead support (10) adapted to be secured to the mask (16) is also disclosed.



WO 00/78384 A1



**(84) Designated States (regional):** ARIPO patent (GH, GM, KE, LS, MW, SD, SL, SZ, TZ, UG, ZW), Eurasian patent (AM, AZ, BY, KG, KZ, MD, RU, TJ, TM), European patent (AT, BE, CH, CY, DE, DK, ES, FI, FR, GB, GR, IE, IT, LU, MC, NL, PT, SE), OAPI patent (BF, BJ, CF, CG, CI, CM, GA, GN, GW, ML, MR, NE, SN, TD, TG).

**Published:**

— *With international search report.*

*For two-letter codes and other abbreviations, refer to the "Guidance Notes on Codes and Abbreviations" appearing at the beginning of each regular issue of the PCT Gazette.*

## FOREHEAD SUPPORT FOR FACIAL MASK

### FIELD OF THE INVENTION

The present invention relates to a forehead support for a facial mask used to supply breathable gas to a wearer's airways.

The invention has been developed primarily for use in supporting a nasal mask used in Continuous Positive Airway Pressure (CPAP) treatment of, for example, Obstructive Sleep Apnea (OSA) and other ventilatory assistance treatments such as Non-Invasive Positive Pressure Ventilation (NIPPV) and will be described hereinafter with reference to this application. However, it will be appreciated that the invention is not limited to these particular uses and is also suitable for use with, for example, full-face (ie. nose and mouth) masks.

### BACKGROUND OF THE INVENTION

CPAP treatment is a common ameliorative treatment for breathing disorders including OSA. CPAP treatment, as described in US Patent No. 4,944,310, provides pressurised air or other breathable gas to the entrance of a patient's airways at a pressure elevated above atmospheric pressure, typically in the range 4-20cm H<sub>2</sub>O.

It is also known for the level of treatment pressure to vary during a period of treatment in accordance with patient need, that form of CPAP being known as automatically adjusting nasal CPAP treatment, as described in US Patent No. 5,245,995.

NIPPV is another form of treatment for breathing disorders which can involve a relatively higher pressure of gas being provided in the patient mask during the inspiratory phase of respiration and a relatively lower pressure or atmospheric pressure being provided in the patient mask during the expiratory phase of respiration.

In other NIPPV modes the pressure can be made to vary in a complex manner throughout the respiratory cycle. For example, the pressure at the mask during inspiration or expiration can be varied through the period of treatment, as disclosed in the applicant's international PCT patent application No. PCT/AU97/00631.

Typically, the ventilatory assistance for CPAP or NIPPV treatment is delivered to the patient by way of a nasal mask. Alternatively, a mouth mask or full face mask or nasal prongs can be used. In this specification any reference to a mask is to be understood as incorporating a reference to a nasal mask, mouth mask, full face mask or nasal prongs, unless otherwise specifically indicated.

In this specification any reference to CPAP treatment is to be understood as embracing all of the above described forms of ventilatory treatment or assistance.

A CPAP apparatus broadly comprises a flow generator constituted by a continuous source of air or other breathable gas such as a hospital piped supply or a blower. In the latter case, an electric motor drives the blower and is typically controlled by a servo-controller under the control of a microcontroller unit. In either  
5 case, the gas supply is connected to a conduit or tube which in turn is connected to a patient nasal or full-face mask which incorporates, or has in close proximity, an exhaust to atmosphere for venting exhaled gases. Examples of prior art nasal masks are shown in U.S. Patent Nos. 4,782,832 and 5,243,971.

The supply conduit delivers gas into a chamber formed by walls of the mask.  
10 The mask includes a cushion positioned against the wearer's face and is normally secured to the wearer's head by straps. The straps are adjusted to pull the mask against the face to achieve a gas tight seal between the cushion and the wearer's face.

A problem that arises with existing masks is that with the use of straps, the mask is compressed against the wearer's face and may push unduly hard on the  
15 wearer's nose. Additionally, the mask may move around the wearer's face. Thus, there has been hitherto provided a forehead support, which provides a support mechanism between the mask and the forehead. This forehead support prevents both the mask from pushing too strongly against the wearer's nose and/or facial region as well as minimising movement of the mask with the addition of a contact point between  
20 the mask and the wearer's head thereby reducing uncomfortable pressure points. Additionally, the forehead support can be arranged to prevent the gas supply conduit from contacting the wearer's forehead or face.

Forehead supports with a single cushion and a single contact point on the forehead are known.

25 The applicant's U.S. Patent Application Serial No. 09/008,708 relates to a substantially rigid one-piece forehead support having a pair of forehead cushions mounted at each outer end of the support. This forehead support is connected to the top of a facial mask and includes an adjustment mechanism to allow the spacing between the top of the facial mask and the forehead support to be altered between  
30 predetermined positions to alter the angle of the mask relative to the wearer's head to suit the wearer's facial topography.

The applicant's Australian provisional patent application No. PP9499 relates to a forehead support having a pair of pivotable arms that each have a forehead cushion  
35 mounted at their distal end. This forehead support is connected to the top of a mask and includes an adjustable mechanism to allow the angle between the arms to be altered between predetermined positions to alter the angle of the mask relative to the wearer's head to suit the wearer's facial topography.

It is an object of the present invention to provide an alternate form of forehead support.

## SUMMARY OF THE INVENTION

Accordingly, in a first aspect, the present invention provides a forehead support adapted to be secured to a respiratory mask, said forehead support including a joining member for securing to the mask and a cushion frame pivotally mounted to the joining member, wherein: the cushion frame is adapted to locate one or more forehead cushions; the cushion frame is adapted to pivot relative to the joining member; and the cushion frame is selectively lockable at two or more predetermined angular positions relative to the joining member.

In a second aspect, the present invention provides a respiratory mask assembly comprising a respiratory mask and a forehead support adapted to be secured to the mask, said forehead support including a joining member for securing to the mask and a cushion frame pivotally mounted to the joining member, wherein: the cushion frame is adapted to locate one or more forehead cushions; the cushion frame is adapted to pivot relative to the joining member; and the cushion frame is selectively lockable at two or more predetermined angular positions relative to the joining member.

The cushion frame is preferably T-shaped and includes a forehead cushion at each end of the upper portion of the T.

Preferably, one of the cushion frame or joining member includes a tongue adapted to be received in one of at least two grooves provided on the other of the cushion frame or joining member so as to lock the cushion frame and joining member at one of the two or more predetermined angular positions.

More preferably, a pair of the tongues are provided on the cushion frame and at least two pairs of grooves are provided on the joining member.

The tongue(s) is/are preferably provided on a semi-rigid member which is adapted to permit the tongue(s) to be moved out of engagement with the grooves by manual manipulation of the member. The tongue(s) is/are preferably connected to a button adapted to protrude from the cushion frame to facilitate manual manipulation of the member.

The cushion frame preferably includes means to connect a head strap thereto.

The mask preferably also include means to connect a head strap thereto.

The joining member can be produced from, for example, polypropylene or polycarbonate.

The mask can include a mask shell and a mask cushion. The mask shell can be produced from, for example, polypropylene or polycarbonate.

The cushion frame can be produced from, for example, polypropylene or polycarbonate.

## BRIEF DESCRIPTION OF THE DRAWINGS

Preferred embodiments of the invention will now be described, by way of examples only, with reference to the accompanying drawings in which:

5 Fig. 1 is a front perspective view of a first embodiment of a forehead support according to the invention connected to a nasal mask;

Fig. 2 is a cross sectional side view of the forehead support shown in Fig. 1 with the tongue of the cushion frame engaged with one of the pairs of grooves of the joining member;

10 Fig. 3 is a cross sectional side view of the forehead support shown in Fig. 1 with the tongue of the cushion frame free of engagement with the pairs of grooves of the joining member;

Fig. 4 is a cross sectional side view of the forehead support shown in Fig. 1 adjacent a wearer's head with the tongues and grooves engaged at the first of four positions;

15 Fig. 5 is a cross sectional side view of the forehead support shown in Fig. 1 adjacent a wearer's head with the tongues and grooves engaged in the second of four positions;

20 Fig. 6 is a cross sectional side view of the forehead support shown in Fig. 1 adjacent a wearer's head with the tongues and grooves engaged at the third of four positions;

Fig. 7 is a cross sectional side view of the forehead support shown in Fig. 1 adjacent a wearer's head with the tongues and grooves engaged at the fourth of four positions;

25 Fig. 8 is a partial exploded perspective view of a second embodiment of a forehead support according to the invention.

Fig. 9 is a cross sectional side view of a third embodiment of a forehead support according to the invention that includes an integrally formed cushion frame and joining member;

30 Fig. 10 is a cross sectional view of the forehead support shown in Fig. 9 with the tongue and grooves engaged at the first of four positions.

Fig. 11 is a cross sectional view of the forehead support shown in Fig. 9 with the tongue and grooves engaged at the second of four positions.

Fig. 12 is a cross sectional view of the forehead support shown in Fig. 9 with the tongue and grooves engaged at the third of four positions.

35 Fig. 13 is a cross sectional view of the forehead support shown in Fig. 9 with the tongue and grooves engaged at the fourth of four positions;

Fig. 14 is a cross sectional view of the forehead support shown in Fig. 9 with the tongue free of engagement with the grooves; and

Fig. 15 is a side view, with enlarged details, of a fourth embodiment of a forehead support according to the invention.

#### DETAILED DESCRIPTION OF THE PREFERRED EMBODIMENT

5 Fig. 1 shows a first embodiment of a forehead support 10 according to the present invention. The forehead support 10 includes a generally T-shaped cushion frame 12 pivotally mounted to a joining member 14. The joining member 14 is connected to a nasal respiratory mask 16 used to supply breathable gas to a wearer's airways.

10 The mask 16 includes a mask shell 17 and a mask cushion 19. The mask shell 17 also includes an angled connector 18 which has a distal end 20 for connection to a gas supply conduit (not shown) and a proximal end 22 for connection to the mask 16. The connector 18 communicates the supplied gas from the gas supply conduit to the interior of the mask 16. The mask shell 17 also includes a pair of slotted connectors 24  
15 to which are respectively connected ends of a lower head strap (not shown) for securing the nasal mask to the wearer's head.

The joining member 14 is connected on top of the mask shell 17 generally adjacent and above the wearer's nose. It will be appreciated that the nasal mask 16 shown is just one example of a respiratory mask that could be supported by the  
20 forehead support 10. For example, the forehead support also finds application in supporting full-face (ie. nose and mouth) masks.

Forehead supports according to the invention can also be used with facial masks in which the gas supply connector 18 is incorporated into the mask in the general position of the joining member 14. In this type of mask, the supplied gas flows through  
25 or past the forehead support 10.

The T-shaped cushion frame 12 includes a pair of forehead cushions 25 mounted at each end of the upper portion of the T on the wearer contacting side. Examples of cushions 25 include open or closed cell foam, silicone, dual durometer foams, single pads or multiple pads joined together. The forehead cushions 25 can be  
30 integrally moulded with the frame 12 or attached thereto by clips or adhesives or the like. The frame 12 also includes a slotted connector 26 adjacent each of the forehead cushions 25 to which are respectively connected ends of an upper head strap (not shown) for securing the cushion frame 12 to the wearer's head.

The T-shaped cushion frame 12 also includes a pair of shafts 27 (only one  
35 shown) on the lower portion of the T which are each respectively received in part circular openings 28 (only one shown) provided on the joining member 14. The shafts 27 can pivot or rotate in their respective openings 28 to provide for pivotal or rotational movement between the cushion frame 12 and the joining member 14 about axis 30 in the direction of double-headed arrow 31.

The curved shape of the cushions 25 allows them to effectively "roll" over the wearer's forehead during angular adjustment between the cushion frame 12 and the joining member 14.

As best shown in Figs. 2 and 3, the cushion frame 12 also includes a flexible member 32 which has two side by side spaced apart tongues 34 and a middle protruding button 36 on its distal end. The joining member 14 also includes two generally arcuate shaped portion 38 that each have a pair of four grooves 40. It will be appreciated that the pair of four grooves is merely preferably and that only two or more grooves are required. It will also be appreciated that the flexible member 32 can be on the joining member 14 and the grooves 40 can be on the cushion frame 12. The tongue 34 and the grooves 40 extend in a direction substantially parallel to a line extending radially from the axis 30.

The cushion frame 12 is constructed from a plastics material, such as polypropylene or polycarbonate, which allows the member 32 to be flexed relative to the cushion frame 12 upon which is mounted when pressure is applied to the button 36 in the direction of arrow 42. The corresponding movement of the tongues 34 releases them from engagement with one of the pairs of grooves 40 (as shown in Fig. 3) to allow angular adjustment between the cushion frame 12 and the joining member 14 about the axis 30. Releasing the button 36 allows the tongue 34 to resiliently flex back towards the grooves 40. When the tongues 34 and one of the pairs of grooves 40 are aligned (as shown in Figs. 2 and 4 to 7) the tongues 34 engage one of the pair of grooves 40. When the tongues 34 are engaged with one of the pair of grooves, the cushion frame 12 and joining member 14 are locked against pivotal movement therebetween at a predetermined angle.

Figs. 4 to 7 respectively show forehead support 10 adjacent the heads of different wearers with the tongues 34 engaged in the first, second, third and fourth of the four pairs of grooves 40.

As Figs. 4 to 7 show, the angle between the cushion frame 12 and the joining member 14 adjacent the wearer's forehead can be increased to suit wearer's with relatively high nasal regions and relatively low foreheads (Figs. 4 and 5) and decreased to suit wearers with relatively low nasal regions and relatively high foreheads (Figs. 6 and 7).

In this way the forehead support 10 advantageously allows the mask 16 to be positioned to comfortably suit the particular topography of the wearer's face to ensure the mask cushion 19 is positioned ideally relative to the wearer's face. As examples, the relative position of the cushion frame 12 and the joining member 14 in Fig. 4 would be more suitable for use with a wearer having a shallow forehead or protruding cheeks or nose whilst the position of the cushion frame and joining member 14 in Fig. 7 would be more suitable for use with a wearers having a protruding or bulbous forehead.



Fig. 8 shows a second embodiment of a forehead support 50 according to the present invention. Like reference numerals to those used in describing the first embodiment will be used to denote like features in relation to the second embodiment.

5 In the second embodiment, there are two buttons 36. Pressing the buttons together in the direction of arrows 52 flexes the tongues 34 towards each other to disengage them from the grooves 40 and allow angular adjustment between the cushion frame 12 and the joining member 14. Releasing the buttons 36 allows the tongues 34 to resiliently flex towards, and into engagement with, the grooves 40 to lock the cushion frame 12 and the joining member 14 against relative pivotal movement.

10 Figs. 9 to 14 show a third embodiment of a forehead support 60 according to the present invention. Like reference to those used in describing the first embodiment will also be used to denote like features in relation to the third embodiment.

15 In the third embodiment, the cushion frame 12 is integrally moulded with the joining member 14 and joined by an integral hinge 62 (sometimes known as a natural or living hinge). The cushion frame 12 and the joining member 14 can be pivoted relative to each other about the hinge 62. The forehead support 60 is moulded in a substantially 'flat' configuration, as shown in Fig. 9. The cushion frame 12 is then pivoted through approximately 180° relative to the joining member 14 until the tongue 34 engages one of the four grooves 40. As with the earlier embodiments, pressing the  
20 button 36 in the direction of arrow 42 frees the tongue 34 from engagement with the grooves to allow adjustment of the angle between the cushion frame 12 and the joining member 14. The button 36 and the tongue 34 are inherently biased to a position engaging one of the grooves 40, again consistent with earlier embodiments.

25 In the preferred form shown, the mask shell 17 is also integrally formed with the joining member 14. This simplifies manufacturing and assembly and reduces production costs. The forehead support 60 is preferably manufactured from polypropylene due to its ability to mould integral hinges.

30 Fig. 15 shows a fourth embodiment of a forehead support 100 according to the invention. Like reference to those used in describing the first embodiment will also be used to denote like features in relation to the fourth embodiment.

The fourth embodiment is almost identical to the first embodiment except the tongue 34 and the grooves 40 are angled with respect to a line extending radially from the axis 30 to the tongue 34 or the grooves 40. This angled arrangement reduces the likelihood that the tongue 34 will inadvertently release from engagement with one of the  
35 grooves 40 if the front of the mask 16 is subjected to a force in the direction of the wearer's face.

Although the invention has been described with reference to a specific example, it will be appreciated by those skilled in the art that the invention may be embodied in many other forms.

As an example, the forehead support can include means to resiliently bias the cushion frame and the joining member relative to one another such that they increase or decrease their angle relative to one another when the tongues are disengaged from one of the pairs of slots.

## CLAIMS:

1. A forehead support adapted to be secured to a respiratory mask, said forehead support including a joining member for securing to the mask and a cushion frame pivotally mounted to the joining member, wherein: the cushion frame is adapted to locate one or more forehead cushions; the cushion frame is adapted to pivot relative to the joining member; and the cushion frame is selectively lockable at two or more predetermined angular positions relative to the joining member.
2. The support as claimed in claim 1, wherein the cushion frame is T-shaped and includes a forehead cushion at each end of the upper portion of the T.
3. The support as claimed in claim 1 or 2, wherein one of the cushion frame or joining member includes a tongue adapted to be received in one of at least two grooves provided on the other of the cushion frame or joining member so as to lock the cushion frame and joining member at one of the two or more predetermined angular positions.
4. The support as claimed in claim 3, wherein a pair of the tongues are provided on the cushion frame and at least two pairs of grooves are provided on the joining member.
5. The support as claimed in claim 4, wherein the cushion frame pivots relative to the joining member about an axis and the tongue and grooves extend in a direction substantially parallel to a line extending radially from the axis.
6. The support as claimed in claim 4, wherein the cushion frame pivots relative to the joining member about an axis and the tongue and grooves extend in a direction angled with respect to a line extending radially from the axis.
7. The support as claimed in any one of claims 4 to 6, wherein the tongue(s) is/are provided on a semi-rigid member which is adapted to permit the tongue(s) to be moved out of engagement with the grooves by manual manipulation of the member.
8. The support as claimed in any one of claims 4 to 7, wherein the tongue(s) is/are connected to a button adapted to protrude from the cushion frame to facilitate manual manipulation of the member.
9. The support as claimed in any one of the preceding claims, wherein the cushion frame includes means to connect a head strap thereto.

10. The support as claimed in any one of the preceding claims, wherein the mask include means to connect a head strap thereto.

5 11. The support as claimed in any one of the preceding claims, wherein the joining member is produced from polypropylene or polycarbonate.

12. The support as claimed in any one of the preceding claims, wherein the mask includes a mask shell and a mask cushion.

10 13. The support as claimed in claim 12, wherein the mask shell is produced from polypropylene or polycarbonate.

15 14. The support as claimed in claim in any one of the preceding claims, wherein the cushion frame is produced from polypropylene or polycarbonate.

15 15. The support as claimed in any one of the preceding claims, wherein the cushion frame and the joining member are integrally formed and connected by a integral hinge that allows relative pivoting therebetween.

20 16. A respiratory mask assembly comprising a respiratory mask and a forehead support adapted to be secured to the mask, said forehead support including a joining member for securing to the mask and a cushion frame pivotally mounted to the joining member, wherein: the cushion frame is adapted to locate one or more forehead cushions; the cushion frame is adapted to pivot relative to the joining member; and the  
25 cushion frame is selectively lockable at two or more predetermined angular positions relative to the joining member.

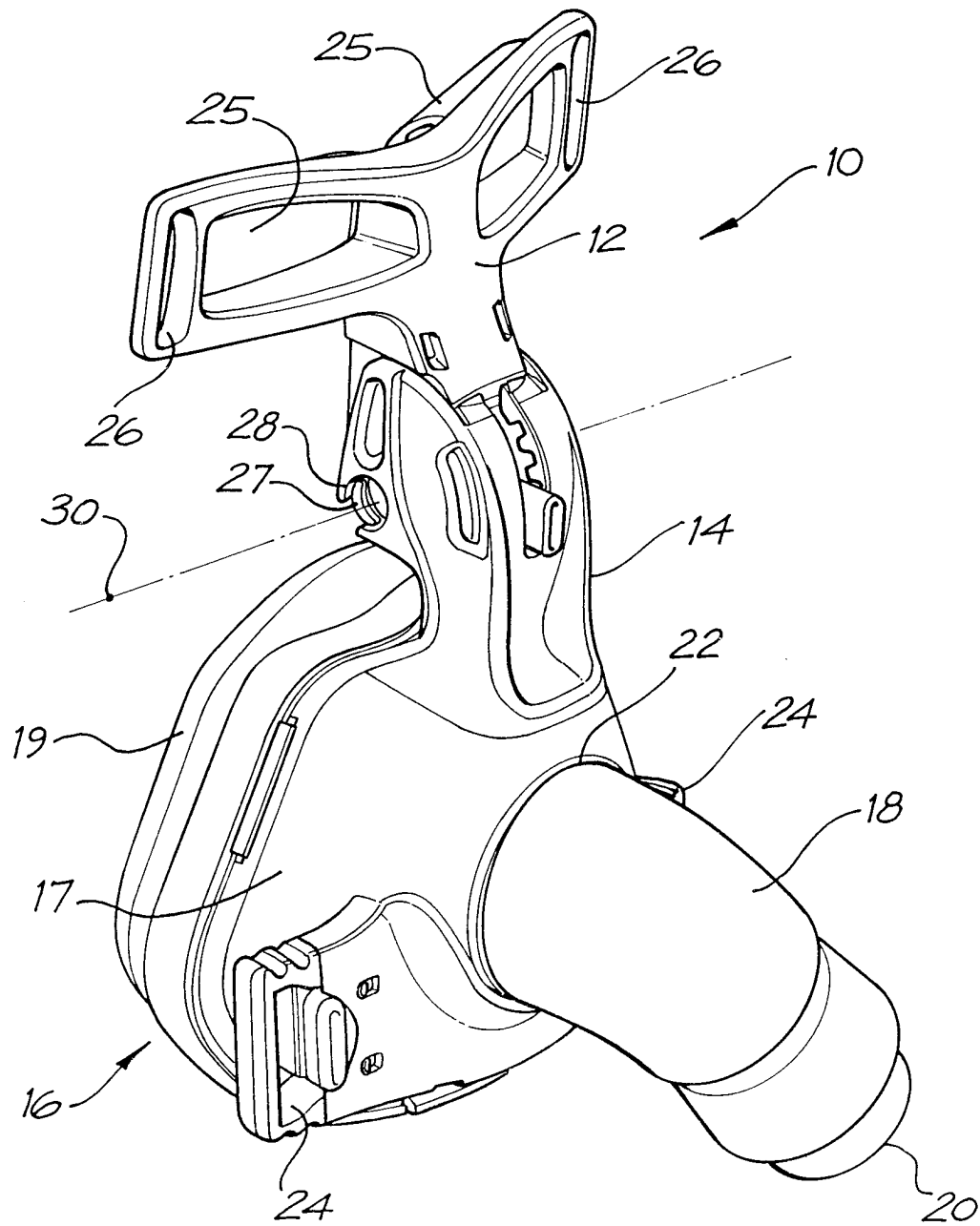

FIG. 1

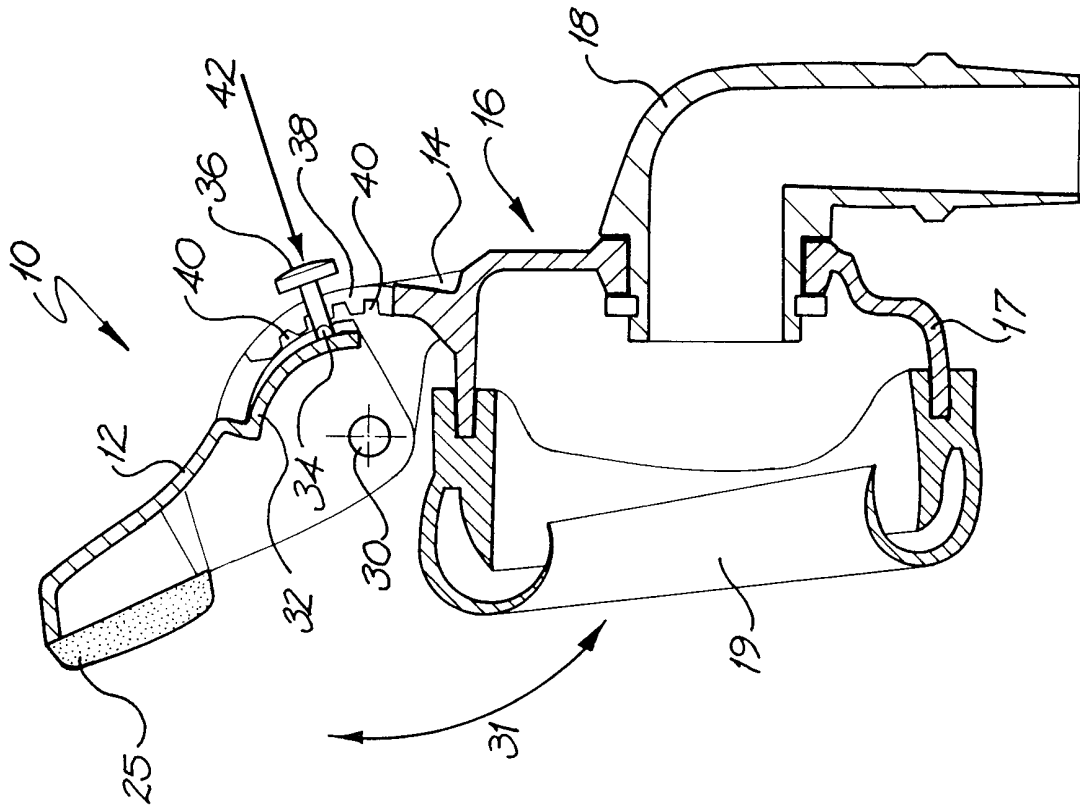

FIG. 3

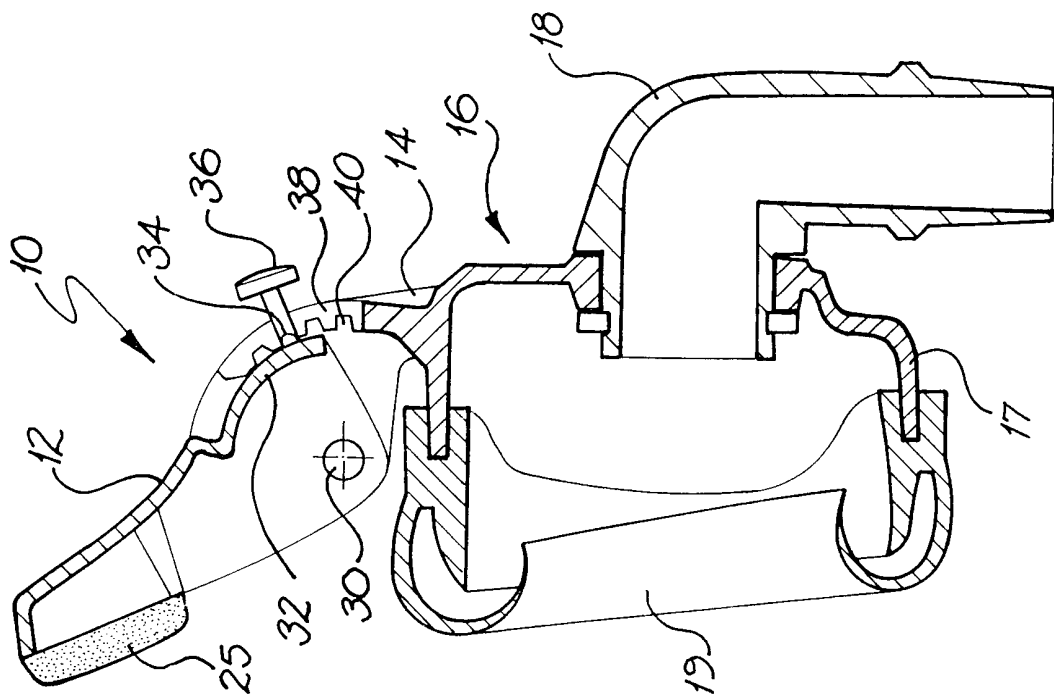

FIG. 2

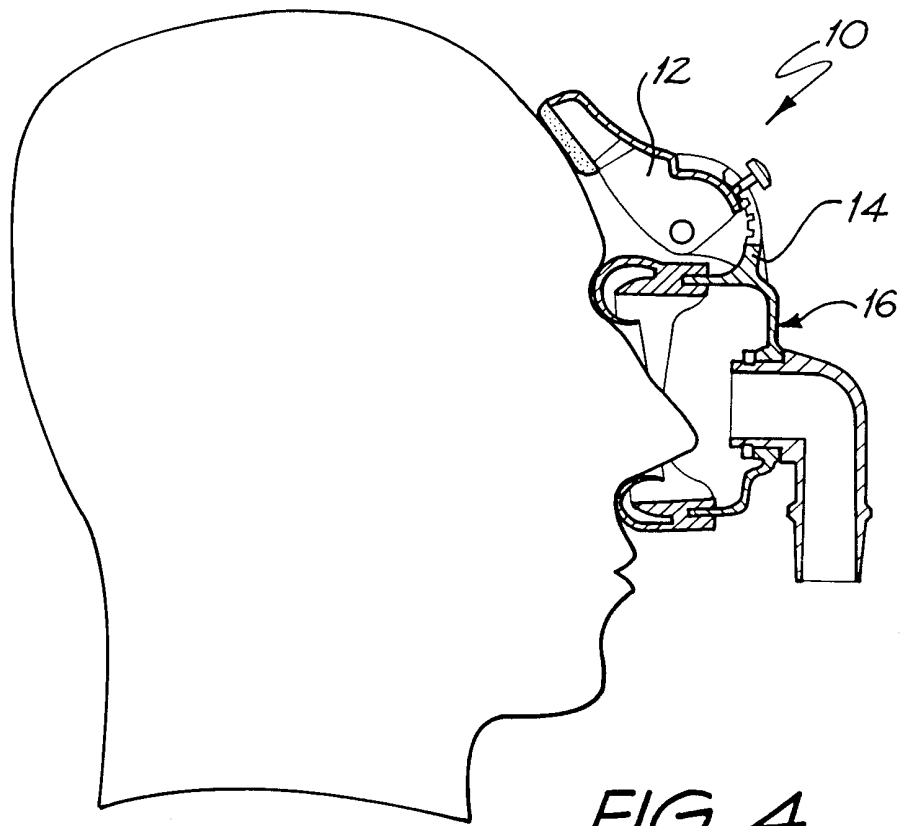

FIG. 4

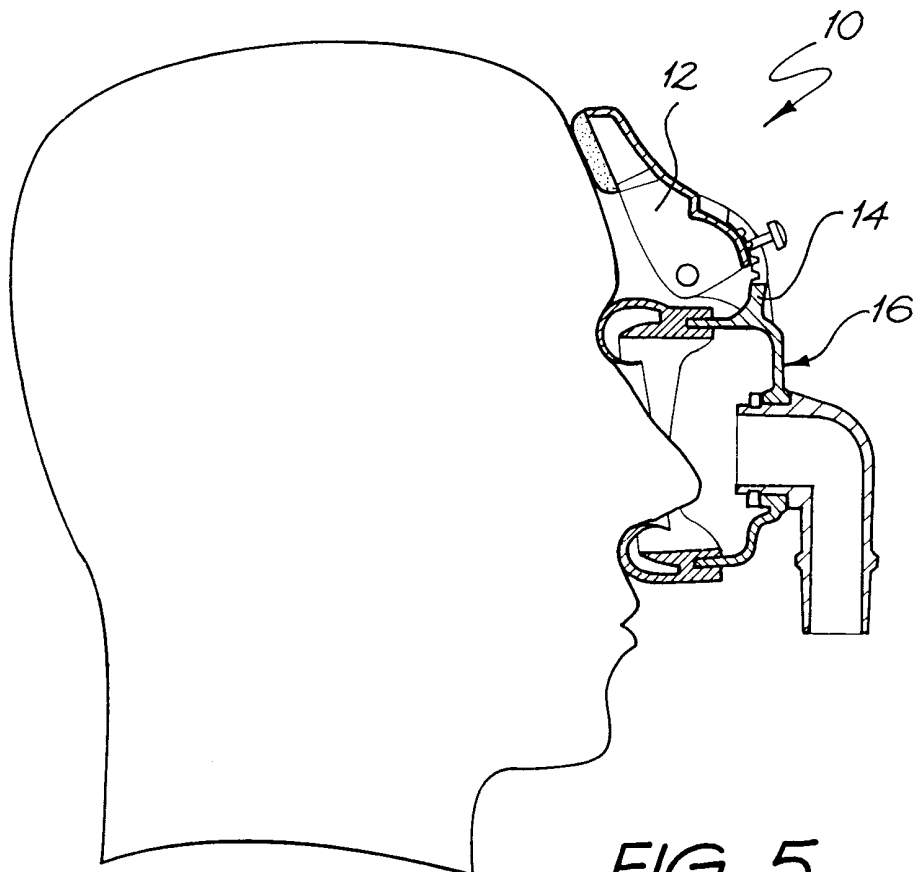
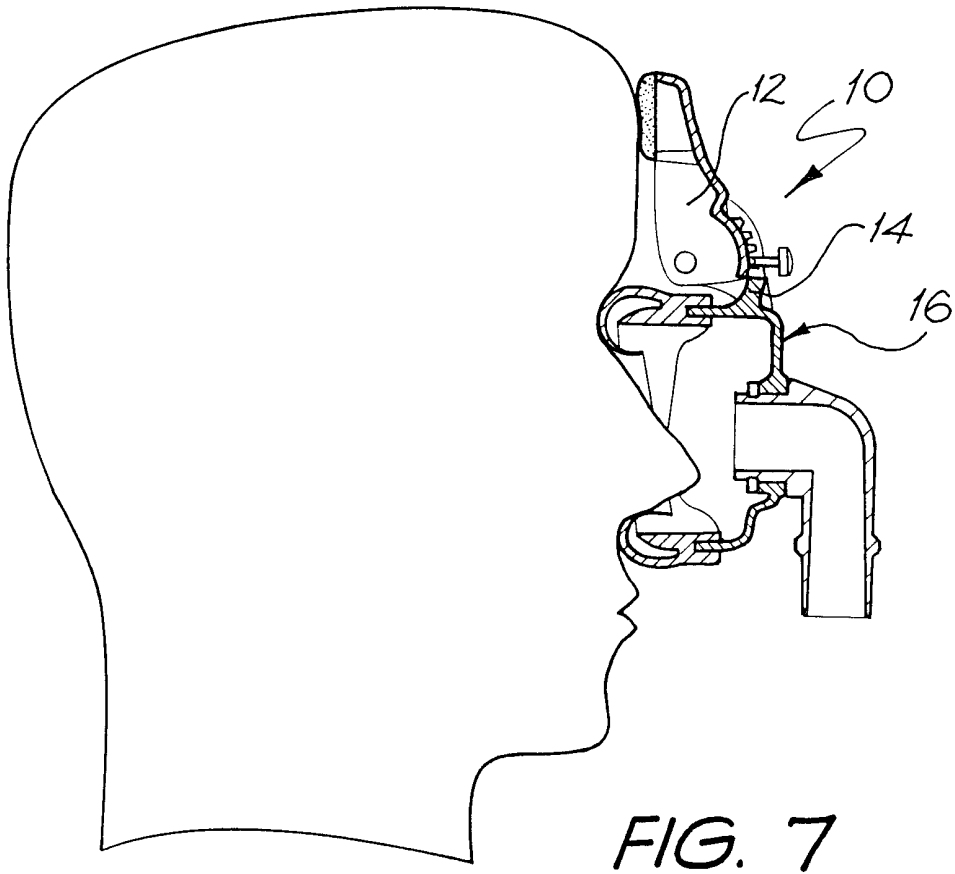
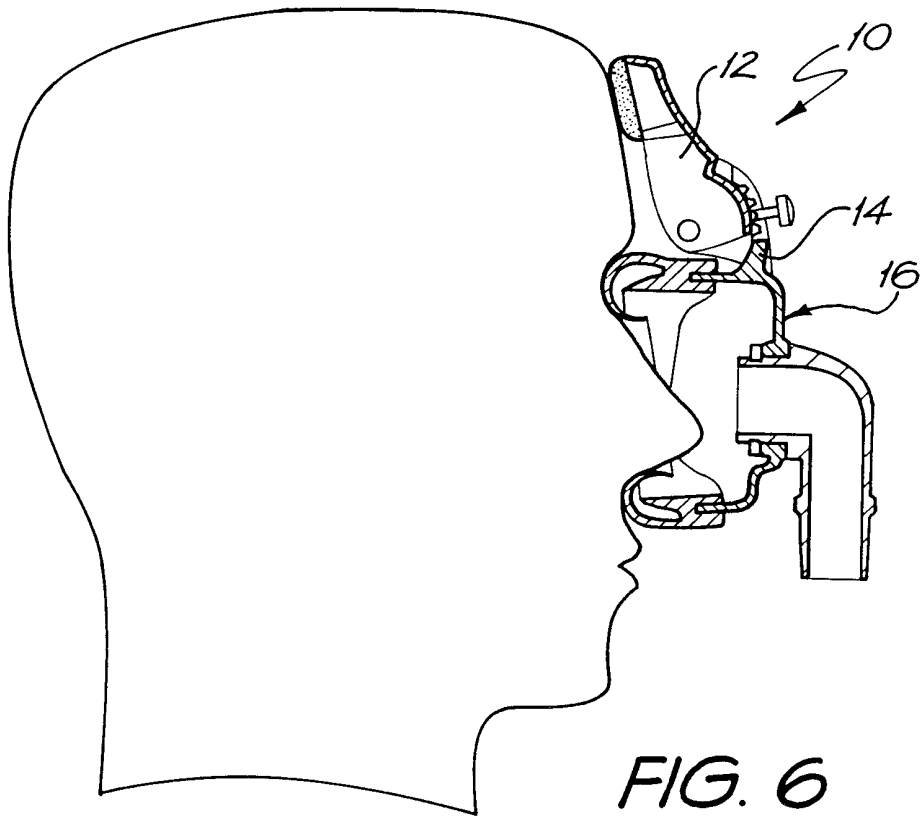

FIG. 5





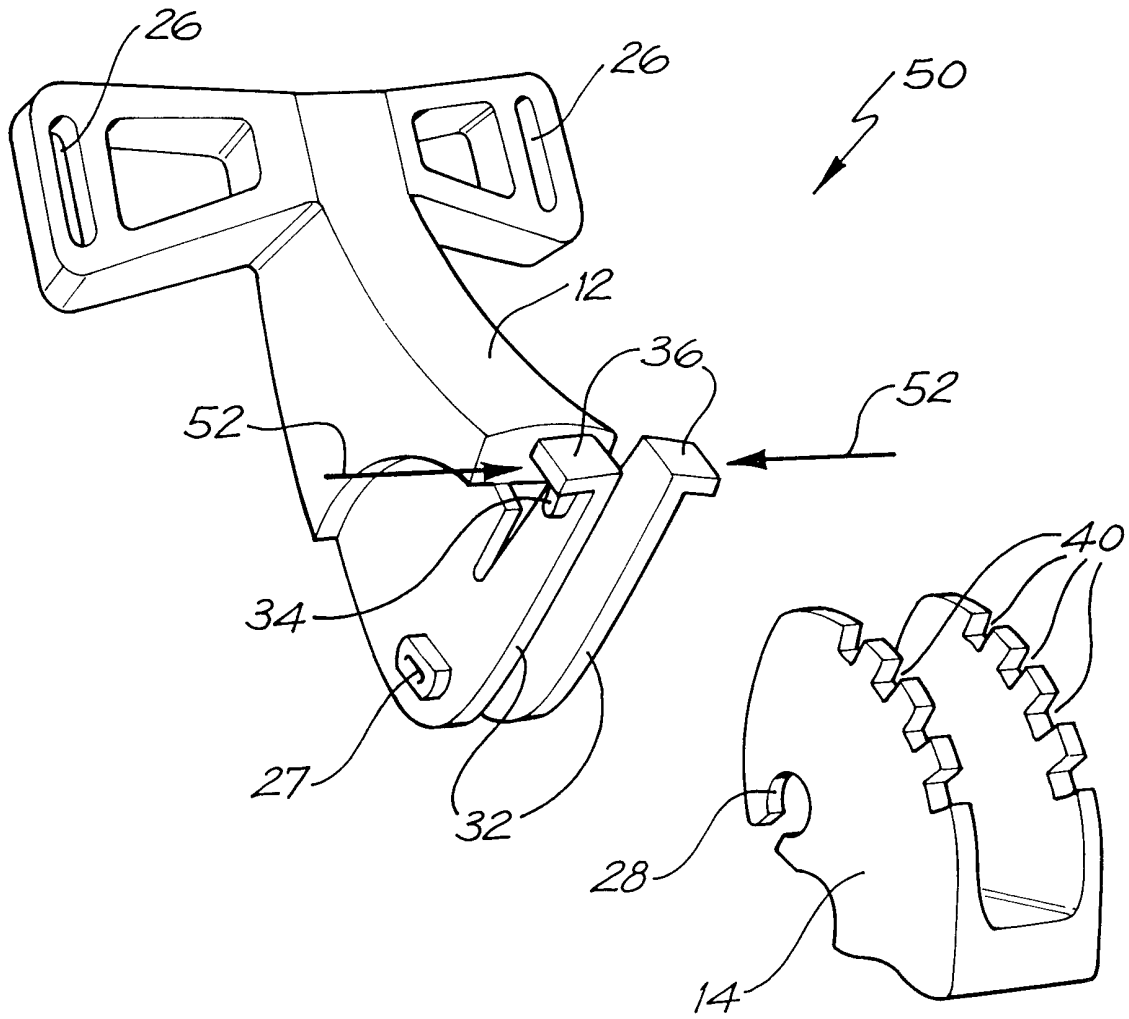
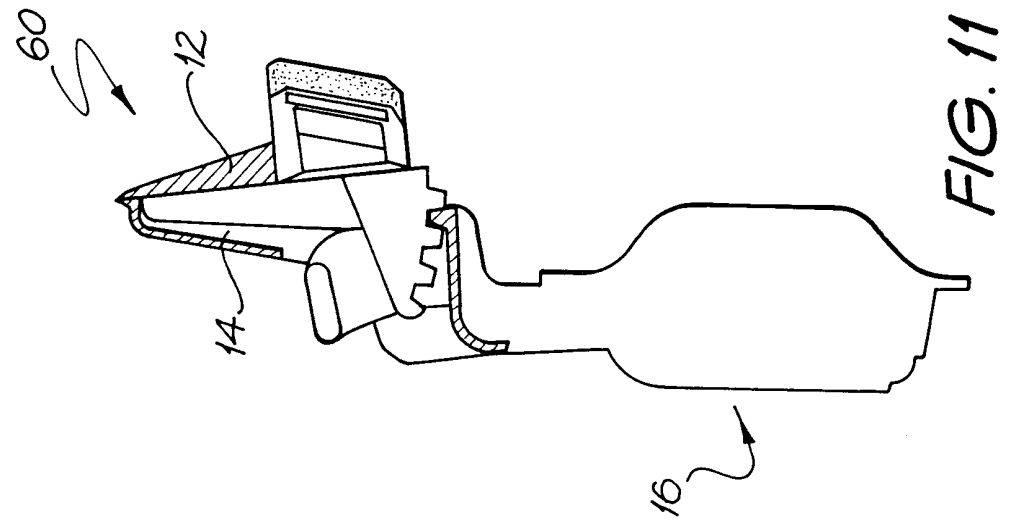
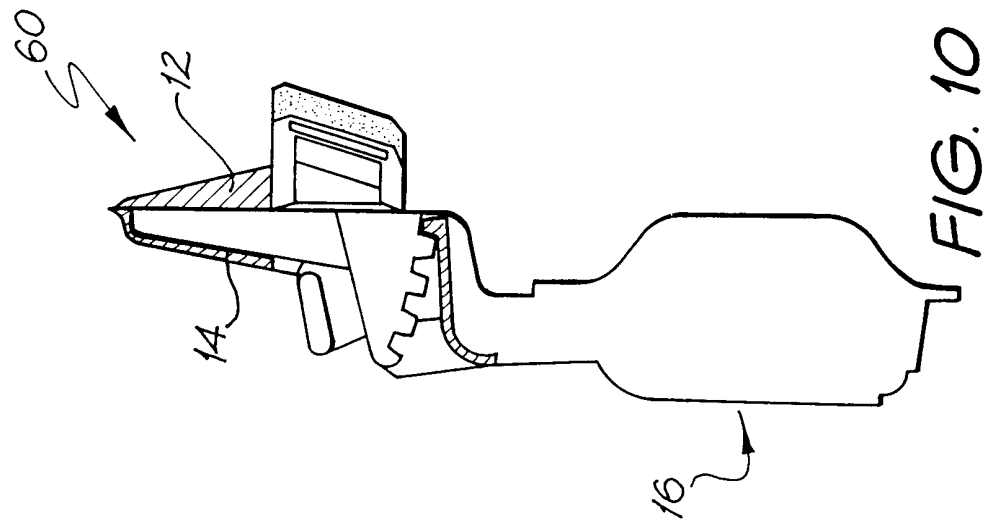
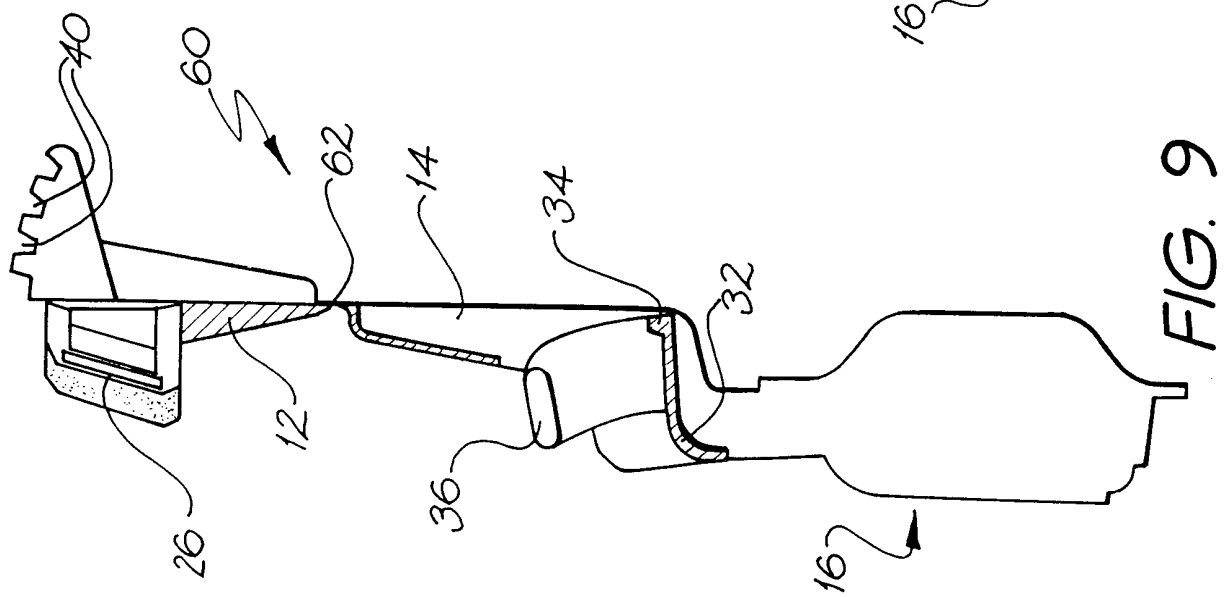

FIG. 8



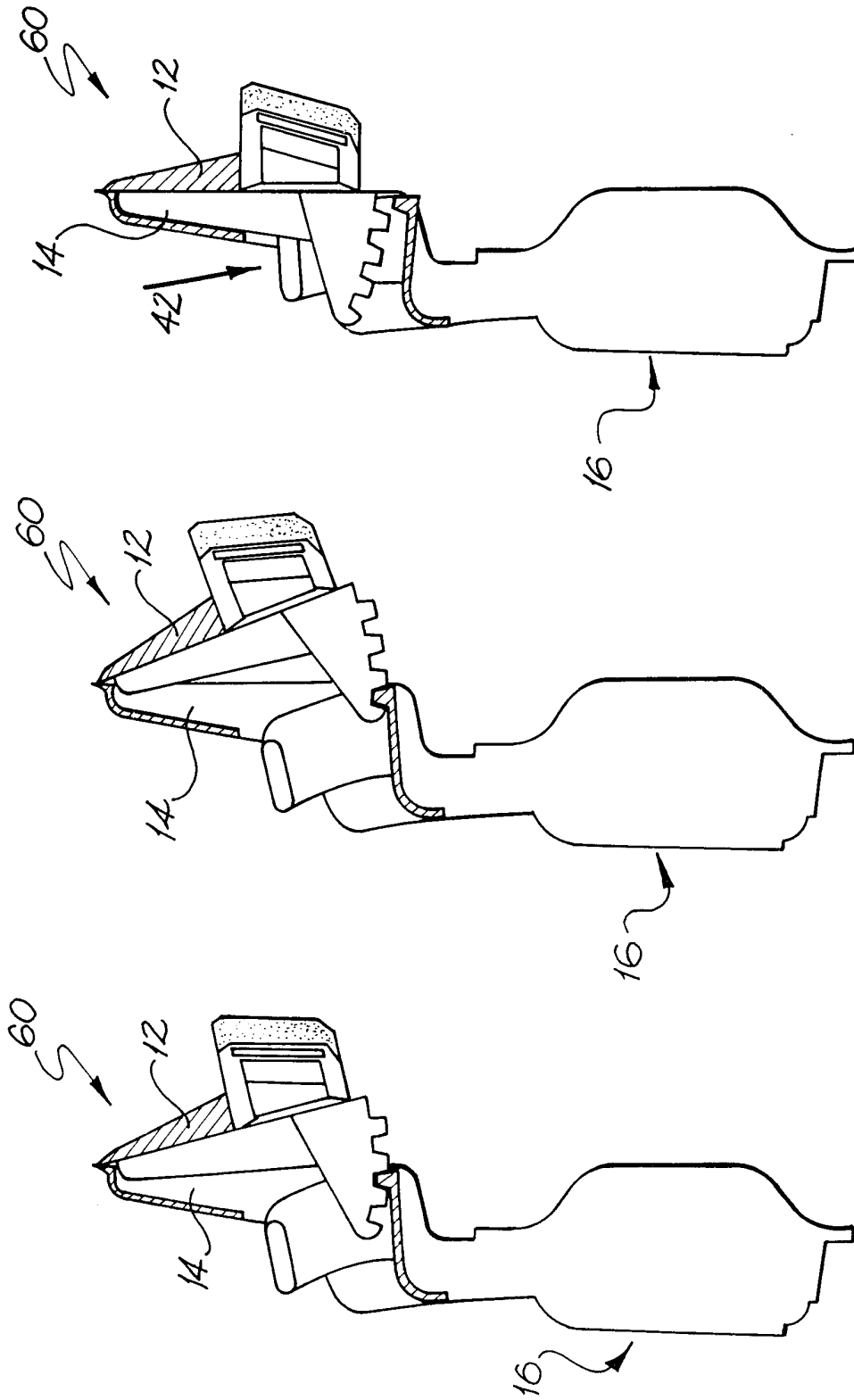

FIG. 14

FIG. 13

FIG. 12

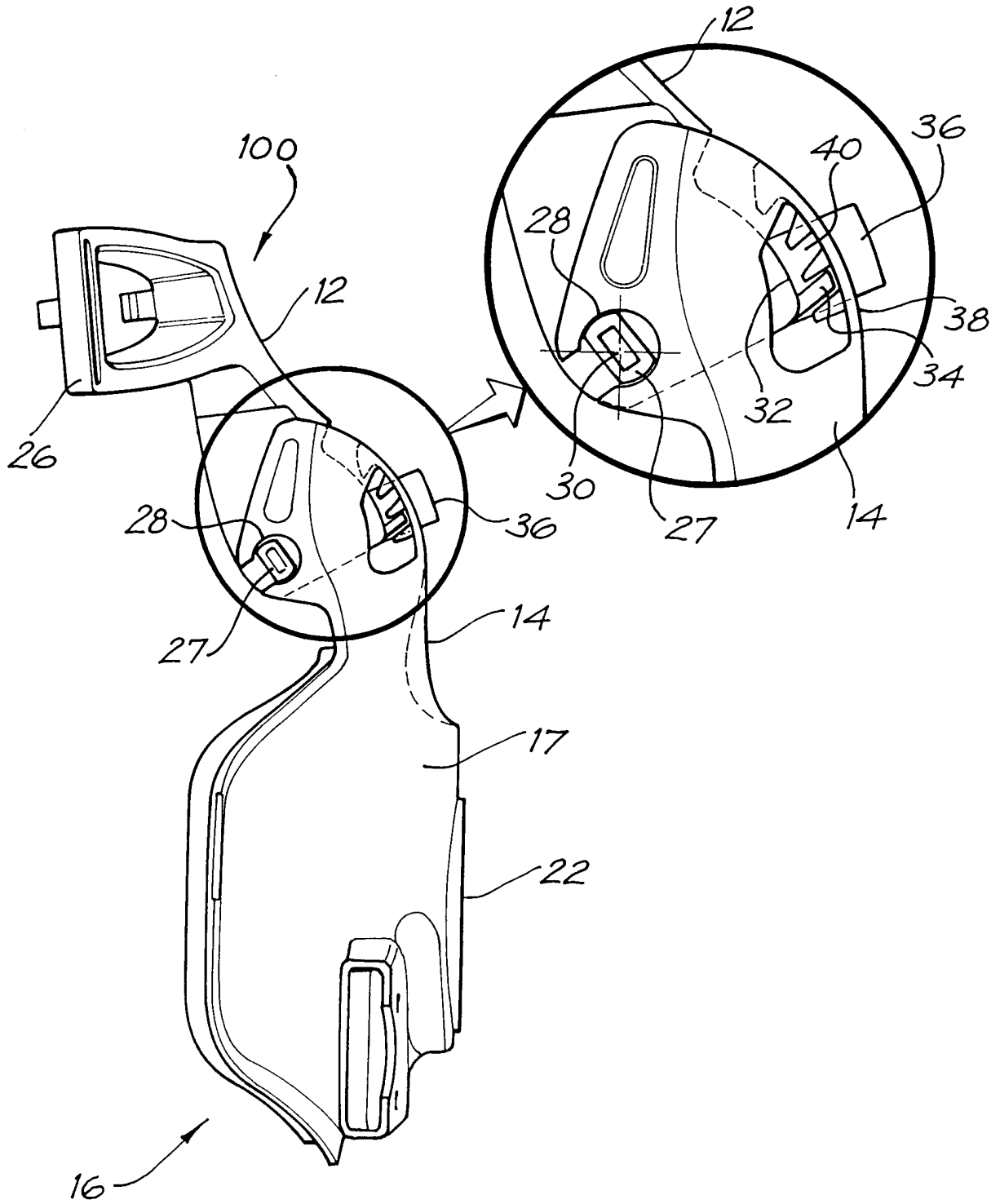

FIG. 15

## INTERNATIONAL SEARCH REPORT

International application No.  
PCT/AU00/00097

<b>A. CLASSIFICATION OF SUBJECT MATTER</b>				
Int. Cl. <sup>7</sup> : A61M 16/06				
According to International Patent Classification (IPC) or to both national classification and IPC				
<b>B. FIELDS SEARCHED</b>				
Minimum documentation searched (classification system followed by classification symbols)				
Documentation searched other than minimum documentation to the extent that such documents are included in the fields searched				
Electronic data base consulted during the international search (name of data base and, where practicable, search terms used) WPAT + keywords				
<b>C. DOCUMENTS CONSIDERED TO BE RELEVANT</b>				
Category*	Citation of document, with indication, where appropriate, of the relevant passages	Relevant to claim No.		
A	Derwent Abstract Accession No. 99-124570/11, Class P34 P35, JP 11-000397 A (Teijin Ltd) 6 January 1999			
A	GB 2186801 A (Smith Industries PLC) 26 August 1987			
<input type="checkbox"/> Further documents are listed in the continuation of Box C <input checked="" type="checkbox"/> See patent family annex				
* Special categories of cited documents: <table border="0" style="width: 100%;"> <tr> <td style="width: 50%; vertical-align: top;">           "A" document defining the general state of the art which is not considered to be of particular relevance            "E" earlier application or patent but published on or after the international filing date            "L" document which may throw doubts on priority claim(s) or which is cited to establish the publication date of another citation or other special reason (as specified)            "O" document referring to an oral disclosure, use, exhibition or other means            "P" document published prior to the international filing date but later than the priority date claimed         </td> <td style="width: 50%; vertical-align: top;">           "T" later document published after the international filing date or priority date and not in conflict with the application but cited to understand the principle or theory underlying the invention            "X" document of particular relevance; the claimed invention cannot be considered novel or cannot be considered to involve an inventive step when the document is taken alone            "Y" document of particular relevance; the claimed invention cannot be considered to involve an inventive step when the document is combined with one or more other such documents, such combination being obvious to a person skilled in the art            "&amp;" document member of the same patent family         </td> </tr> </table>			"A" document defining the general state of the art which is not considered to be of particular relevance "E" earlier application or patent but published on or after the international filing date "L" document which may throw doubts on priority claim(s) or which is cited to establish the publication date of another citation or other special reason (as specified) "O" document referring to an oral disclosure, use, exhibition or other means "P" document published prior to the international filing date but later than the priority date claimed	"T" later document published after the international filing date or priority date and not in conflict with the application but cited to understand the principle or theory underlying the invention "X" document of particular relevance; the claimed invention cannot be considered novel or cannot be considered to involve an inventive step when the document is taken alone "Y" document of particular relevance; the claimed invention cannot be considered to involve an inventive step when the document is combined with one or more other such documents, such combination being obvious to a person skilled in the art "&" document member of the same patent family
"A" document defining the general state of the art which is not considered to be of particular relevance "E" earlier application or patent but published on or after the international filing date "L" document which may throw doubts on priority claim(s) or which is cited to establish the publication date of another citation or other special reason (as specified) "O" document referring to an oral disclosure, use, exhibition or other means "P" document published prior to the international filing date but later than the priority date claimed	"T" later document published after the international filing date or priority date and not in conflict with the application but cited to understand the principle or theory underlying the invention "X" document of particular relevance; the claimed invention cannot be considered novel or cannot be considered to involve an inventive step when the document is taken alone "Y" document of particular relevance; the claimed invention cannot be considered to involve an inventive step when the document is combined with one or more other such documents, such combination being obvious to a person skilled in the art "&" document member of the same patent family			
Date of the actual completion of the international search 2 March 2000		Date of mailing of the international search report 17 MAR 2000		
Name and mailing address of the ISA/AU AUSTRALIAN PATENT OFFICE PO BOX 200, WODEN ACT 2606, AUSTRALIA E-mail address: pct@ipaaustralia.gov.au Facsimile No. (02) 6285 3929		Authorized officer  <b>A.R. HENDRICKSON</b> Telephone No.: (02) 6283 2415		

**INTERNATIONAL SEARCH REPORT**  
Information on patent family members

International application No.  
**PCT/AU00/00097**

This Annex lists the known "A" publication level patent family members relating to the patent documents cited in the above-mentioned international search report. The Australian Patent Office is in no way liable for these particulars which are merely given for the purpose of information.

Patent Document Cited in Search Report		Patent Family Member					
JP	11-000397	--					
GB	2186801	AU	68859/87	CA	1261223	DE	3701878
		FR	2594698	IT	1216870	JP	62-201162
		US	4732147				
END OF ANNEX							