

(19)
(12)

(KR)
(A)

(51) 。 Int. Cl. ⁷
B60H 3/06

(11)
(43)

2002 - 0083804
2002 11 04

(21) 10 - 2001 - 0023455
(22) 2001 04 30

(71) 231

(72) 1022 - 12 202

(74)
:

(54)

가
1
,

2

3 가

4

< >

10 : 20 :

21 : 22 :

23 : 30 :

31 : 32 :

33 : 34 :

40 :

, , 가 ,
 , () , ,
 , .
 3 , (1)가
 , (2) (2)
 (3)가 .
 4 (200)가 ,
 (300)가 .
 , (100) (200) (200) (300)
 (200) (100)

, (300) 가 (100) (200) ,

, 가 (300) (100) 가
가

, , 가 ,

, .

, .

(10) ;

(21) (20) ; (22)가 , (22) (23) ,

(31) (32)가 , (32) (20) (23)
(33)가 , (34) (30) , (30) (34)

, (10) 가 (20) (30) /

, .

1 , 2

, 10 .

(10) , (10)

, (10) (20) (10)가 (21)가
, (21) (22)가 .

, (20) (22) (30) (33)
(23) .

, (30) (20) (20)
(31) (10)가 .

, (30) (32)가 , (32)
 (23) (33)가 , (34)
 (20) (30) , / .
 , (40) , (10)
 (20) (30) (10) .
 , (30) (34) (30) (20) (34)
 , (10) (10) (20) (21) (22)
 , (40)가

, 가 ,
 가 .

(57)

1.

(31) (32)가 , (32)
 (33)가 , (34) (30) , (20) (23)
 (30) (33) , (30) (34)

2.

1 , (10) 가 (20) (30) /

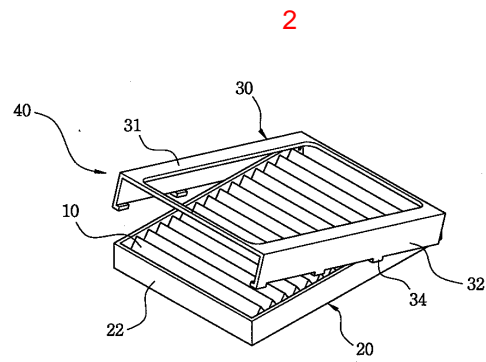
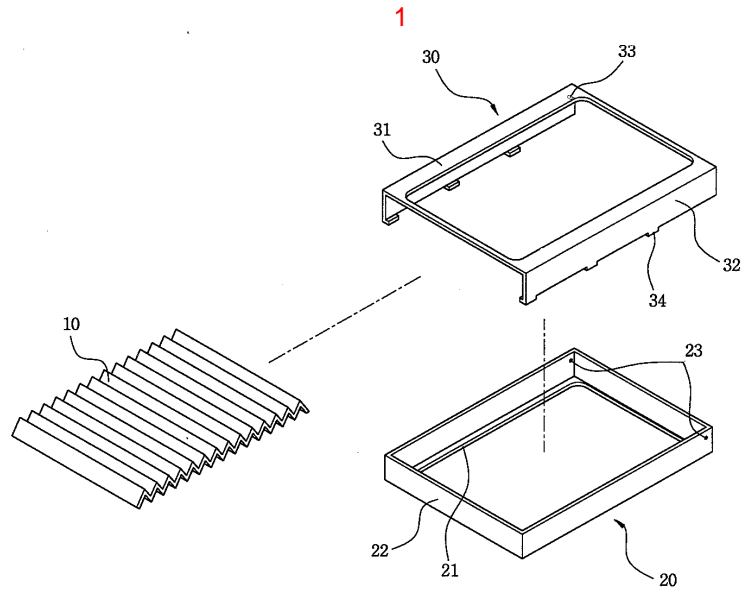

3

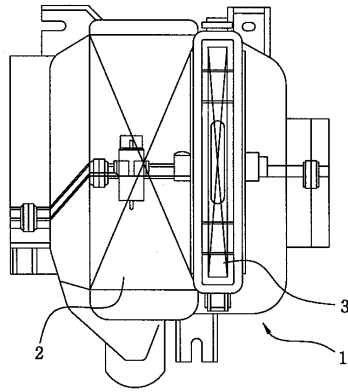

4

