

(19)



(11)

**EP 2 236 971 A3**

(12)

**EUROPEAN PATENT APPLICATION**

(88) Date of publication A3:  
**05.03.2014 Bulletin 2014/10**

(51) Int Cl.:  
**F28F 1/12 (2006.01)**

(43) Date of publication A2:  
**06.10.2010 Bulletin 2010/40**

(21) Application number: **10003127.7**

(22) Date of filing: **24.03.2010**

(84) Designated Contracting States:  
**AT BE BG CH CY CZ DE DK EE ES FI FR GB GR  
 HR HU IE IS IT LI LT LU LV MC MK MT NL NO PL  
 PT RO SE SI SK SM TR**  
 Designated Extension States:  
**AL BA ME RS**

(72) Inventors:  
 • **Jianlong, Jiang  
 Zhejiang 310018 (CN)**  
 • **Huang, Lin-jie  
 East Amherst  
 NY 14051 (US)**

(30) Priority: **25.03.2009 CN 200910119663**

(74) Representative: **Knoblauch, Andreas  
 Patentanwälte Dr. Knoblauch  
 Schlosserstrasse 23  
 60322 Frankfurt am Main (DE)**

(71) Applicants:  
 • **Sanhua Holding Group Co., Ltd.  
 Zhejiang Province 312500 (CN)**  
 • **Danfoss A/S  
 6430 Nordborg (DK)**

**(54) Fin for heat exchanger and heat exchanger using the fin**

(57) The present invention discloses a fin for a heat exchanger, the fin comprises a plurality of fin plates (10) which are adjacent to one another, each of the fin plates (10) is formed with louvers (20); and a connecting portion which connects adjacent fin plates at an end of the adjacent fin plates. The connecting portion comprises a middle curved section (31) and side curved sections (32)

located on the sides of the middle curved section (31), and the curvature radius of the middle curved section (31) is larger than the curvature radius of the side curved sections (32). With the technical solution of the invention, since the contact area between the flat tubes and the fin increases, the fin efficiency is increased and thus the heat exchange performance of the heat exchanger is enhanced.

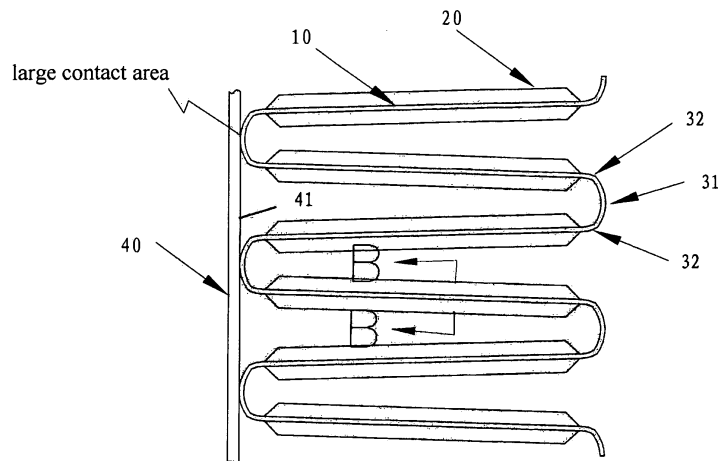

Fig. 4

**EP 2 236 971 A3**



EUROPEAN SEARCH REPORT

Application Number  
EP 10 00 3127

DOCUMENTS CONSIDERED TO BE RELEVANT			
Category	Citation of document with indication, where appropriate, of relevant passages	Relevant to claim	CLASSIFICATION OF THE APPLICATION (IPC)
X	FR 2 854 235 A1 (VALEO CLIMATISATION [FR]) 29 October 2004 (2004-10-29) * figure 4 *	1-15	INV. F28F1/12
X	----- JP H05 154592 A (SHOWA ALUMINUM CORP) 22 June 1993 (1993-06-22) * figure 2 *	1-15	
X	----- FR 2 798 990 A1 (DENSO CORP [JP]) 30 March 2001 (2001-03-30) * figure 7 *	1-15	
X	----- WO 2004/013559 A1 (BEHR GMBH & CO [DE]; RICHTER RAINER [DE]; WOELK GERRIT [DE]; BOCHERT R) 12 February 2004 (2004-02-12) * figure 1 *	1-15	
X	----- JP H01 305296 A (DIESEL KIKI CO) 8 December 1989 (1989-12-08) * figures 1-2 *	1-15	
			TECHNICAL FIELDS SEARCHED (IPC)
			F28F
The present search report has been drawn up for all claims			
Place of search Munich		Date of completion of the search 23 January 2014	Examiner Vassoille, Bruno
CATEGORY OF CITED DOCUMENTS		T : theory or principle underlying the invention E : earlier patent document, but published on, or after the filing date D : document cited in the application L : document cited for other reasons ..... & : member of the same patent family, corresponding document	
X : particularly relevant if taken alone Y : particularly relevant if combined with another document of the same category A : technological background O : non-written disclosure P : intermediate document			

1  
EPO FORM 1503 03.02 (F04C01)

ANNEX TO THE EUROPEAN SEARCH REPORT  
ON EUROPEAN PATENT APPLICATION NO.

EP 10 00 3127

This annex lists the patent family members relating to the patent documents cited in the above-mentioned European search report. The members are as contained in the European Patent Office EDP file on  
The European Patent Office is in no way liable for these particulars which are merely given for the purpose of information.

23-01-2014

Patent document cited in search report	Publication date	Patent family member(s)	Publication date
FR 2854235 A1	29-10-2004	NONE	
JP H05154592 A	22-06-1993	JP 3156008 B2 JP H05154592 A	16-04-2001 22-06-1993
FR 2798990 A1	30-03-2001	FR 2798990 A1 GB 2356040 A JP 4207331 B2 JP 2001099593 A US 6213196 B1	30-03-2001 09-05-2001 14-01-2009 13-04-2001 10-04-2001
WO 2004013559 A1	12-02-2004	AU 2003255295 A1 BR 0305705 A CN 1672006 A DE 10235038 A1 EP 1527311 A1 JP 2005534888 A US 2005229630 A1 WO 2004013559 A1 ZA 200409593 A	23-02-2004 19-10-2004 21-09-2005 12-02-2004 04-05-2005 17-11-2005 20-10-2005 12-02-2004 08-09-2005
JP H01305296 A	08-12-1989	NONE	

EPO FORM P0453

For more details about this annex : see Official Journal of the European Patent Office, No. 12/82