

(19)



Europäisches Patentamt
European Patent Office
Office européen des brevets



(11)

EP 0 839 723 A1

(12)

EUROPEAN PATENT APPLICATION

(43) Date of publication:
06.05.1998 Bulletin 1998/19

(51) Int Cl. 6: B65B 61/08, B65B 11/10,
B26D 1/40, B26D 7/14

(21) Application number: 97830541.5

(22) Date of filing: 23.10.1997

(84) Designated Contracting States:
AT BE CH DE DK ES FI FR GB GR IE IT LI LU MC
NL PT SE
Designated Extension States:
AL LT LV RO SI

(72) Inventors:
• Bettini, Rodolfo
40128 Bologna (IT)
• Ponti, Giuseppe
40127 Quarto Inferiore (Bologna) (IT)

(30) Priority: 31.10.1996 IT BO960555

(74) Representative: Lanzoni, Luciano
c/o BUGNION S.p.A.
Via dei Mille, 19
40121 Bologna (IT)

(71) Applicant: DIMAC S.P.A.
40064 Ozzano dell'Emilia-Bologna (IT)

(54) Device for feeding and cutting film in product packaging machines

(57) A device for feeding and cutting film (2) comprises a pair of counter-rotating rollers (9, 10) positioned in proximity of a slot (8), and between which is interposed, in a first tangential contact point (P1), the film (2). The first roller (9) is fitted with a knife (11) radially protruding from the roller itself, while the second roller (10) is fitted with a radial throat (12) housing the knife (11) during a cutting rotation, and with a plane facet (13) on its surface which defines a free passage channel for the film (2). Driving means (14) allow the rollers (9, 10) to operate: an arrest in the rotation of the rollers (9, 10)

in a waiting configuration wherein the facet (13) is in proximity of the first tangential contact point (P1) so as to allow a quantity of film (2) to unreel towards a transport plane (3) and through the free passage channel; a subsequent activation of the rollers (9, 10) for cutting the film (2) on a free rear edge (2b) so as to obtain a section (S), and a rotation of the rollers (9, 10), for a round angle until they return to the waiting configuration, to feed a subsequent free edge (2a) to the slot (8). Means (15) for holding the film (2) are provided to maintain it in contact with the second roller (10) during the cutting phase.

FIG 1

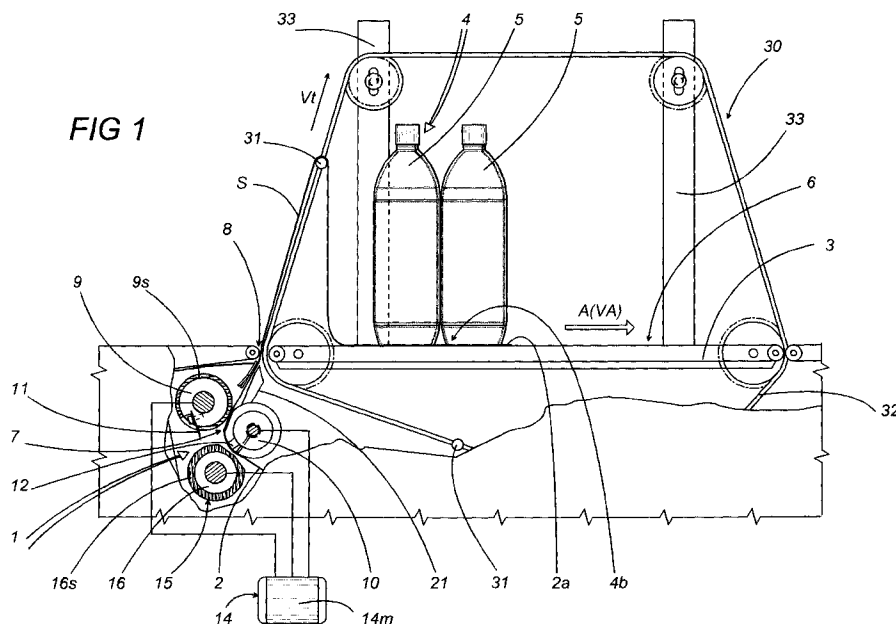

EP 0 839 723 A1

Description

The present invention relates to a device for feeding and cutting film in product packaging machines, with particular reference to the treatment of products such as bottles, cans or any product with cylindrical - parallel-piped shape.

At present, automated machines of the aforesaid kind present a line for working upon and feeding bottles to subsequent intermediate stations for positioning and forming the products and stations for wrapping or packaging groups of products in plastic wrappers.

The purpose of the intermediate positioning and forming stations is to define, by number, pre-determined groups of products (which vary depending on the dimensions and on the packaging to be performed, for instance in the case of bottles it may be defined by two rows comprising three successive bottles) and to transport the products towards the aforesaid wrapping stations, at the end of which the group of products thus defined leaves the station and moves on, through a transport line, to a final station for the definition of the packaging of the products themselves, normally by means of heat-shrinking film.

The aforesaid wrapping packaging stations are provided with a system for feeding a reeled film (which will make up the aforesaid wrappers) made of plastic material, heat-shrinking, continuously fed by a related station placed lower than the product transport plane. This feeding station carries the film, through an appropriate conveyor belt and according to a direction matching the direction of advance of the products, to the transport plane of the products themselves; here, an appropriate wrapping "bridge" guides (through the use of bars for the suspension of the film, driven by parallel chains) the film above the groups and allows them to be wrapped during the advance. In practice the group of products is wrapped by the film which unreels along the same direction of advance as the products, film which presents its ends partially overlapping at the end of the wrapping and which leaves the group of products open in correspondence with the vertical lateral faces of the group. The shrinking of the film on the product itself will be defined by the heat-shrinking characteristic of the film, as is well known in this sector.

Prior art designs, with regard to the station for feeding and cutting the just-described film, are essentially as follows: the first one (see the Applicant's patent EP 491.666) comprises a cutting and feeding group provided with means for supporting and moving a knife, comprising in turn a pair of chains, parallel and opposite to each other, closed in a loop on a corresponding pair of gear wheels whereof one is motor-driven and in phase with the machine; the pair of chains supports the knife rigidly and bilaterally so as to allow it to be moved continuously, through a nearly oval track, such as to bring the knife itself, cyclically, into a position (perpendicular to a transport plane and in correspondence thereto) in-

terfering with and cutting a section of film at a speed higher than the speed of advance of the film.

A second solution, by the same Applicant (see patent EP 581.747), entails a structure comprising a knife positioned immediately below the transport plane of the products, a pair of film-feeding rollers positioned upstream of the knife with respect to the direction of advance of the film. The knife, in order to cut, is moved along a straight line, in both directions, and cross-wise with respect to the development of the film. The unreeling and cutting times are obtained by means of a device comprising a pair of opposite walls, positioned on the transport plane and supporting a plurality of gear wheels positioned at different heights from the plane. Such wheels drive related chains closed in a loop, supporting a series of bars. The adjustable setting of the wheels with respect to the transport plane determines a series of positions of the bars ranging from: intercepting the film subsequent to the interception of its end by a group of products; to the vertical lifting, above the group of products, of the unreeling film; to the subsequent approach to the plane with pause in the unreeling of the film which allows it to be cut; to an advance with respect to the transport plane with retrieval of the film over the products, with its release in correspondence with the front face of the group of products.

All these solutions, however, have shown drawbacks of various kinds: in the first case, the cutting group comprises a complex structure in order to obtain a high level of productivity for the entire station, particularly in regard to the speed of execution and to the number of sections of film produced per unit of time, and therefore it is only advantageous if it is inserted within machines with high productivity which require high performance from the cutting groups, and which therefore can justify high acquisition prices.

The second solution is definitely cheaper than the first one, but it is limited in the amount of film sections cut per unit of time; limitations due mostly to the architecture given to the run of the bars which guide the film as it unreels, which must effect a pause in the unreeling of the film to allow the extreme edge to be cut. This solution, therefore, is better suited to machines positioned differently in the market from the previous one, i.e. machines with lower productivity, per unit of time, than the solutions mentioned above.

The Applicant, in order to improve and complete a broader range of the aforesaid product packaging machines, has conceived and constructed a device for feeding and cutting films so structured as to allow a high cutting rate per unit of time, but, at the same time, to maintain its production costs low. The technical characteristics of the invention, according to the aforesaid purposes, can clearly be seen from the content of the claims reported below and its advantages shall be made more evident in the detailed description that follows, made with reference to the attached drawings, which show an embodiment provided purely by way of non limiting ex-

ample, wherein:

- Figure 1 shows a part of a product packaging machine fitted with the film feeding and cutting device constituting the object of the present invention; the figure is a schematic side view with some parts removed the better to show others;
- Figure 2 shows an enlarged detail with respect to Figure 1 of the film feeding and cutting device in a configuration for letting the film pass through; the figure is a schematic side view with some parts removed the better to show others;
- Figure 3 shows the detail as per Figure 2 in a configuration for cutting the film;
- Figure 4 shows a diagram of the parts driving the device as per the previous figures; the figure is a schematic side view with some parts removed the better to show others.

According to the figures of the attached drawings, and with particular reference to Figure 1, the subject device allows feeding and cutting film in product packaging machines, machines which in the case shown here, purely by way of non limiting example, package bottles indicated as 5.

These machines also comprise a station 1 for feeding the plastic film 2 by a continuous reel (not shown here) in phase with the rest of the movements of the machines. The feeding station 1 is positioned in a place below a transport plane 3 of groups 4 of bottles 5, which travel with a horizontal direction of advance A and at a feeding speed V_a in order to feed a station 6 for wrapping the group 4 with a section S of the aforesaid film 2.

More specifically, the feeding station 1 is fitted with cutting means 7 set cross-wise with respect to the development of the machine, which means 7 define the section S with a pre-defined length of the film 2, and always in phase with the rest of the machine.

As can be clearly seen in Figures 2 and 3, such cutting means 7 comprise a pair of rollers 9 and 10 with counter-rotating motion around respective parallel axes Y and Y'. Rollers 9 and 10 are positioned in proximity of a pass-through slot 8, and between them is interposed, in correspondence with a first tangential contact point (indicated as P1), the aforesaid transiting film 2.

The first roller 9, fitted with a rubber-covered surface 9s, is provided with a knife 11 protruding radially from the first roller itself; which knife 11 can be partially housed, during a cutting rotation (which shall be seen better further on in the description), inside a radial throat 12 presented by the second roller 10.

The latter roller is also fitted with a plane facet 13 on its outer surface, obtained downstream from the throat 12 with respect to the direction of rotation, indicated as S1, of the second roller 10. Such first facet 13 defines a free passage channel for the film 2.

in Figures 1 and 4, the designation 14 indicates adjustable means for imparting motion to the aforesaid two

rollers 9 and 10, means 14 which may comprise, for instance, a single brushless motor 14m connected kinematically, in a direct manner, to the two rollers 9 and 10 by means of a belt 14c and related pulleys 14p, 9p and 10p, or through another direct or indirect driving means through coupling and uncoupling clutch groups (not shown here).

With such drive 14 it is possible to obtain a succession of phases of the rollers 9 and 10 subdivided as follows: an arrest in the rotation of the rollers 9 and 10 in a configuration, shown in Figure 2, such as to position the aforesaid first facet 13 of the second roller 10 in proximity of the first point 13 of tangential contact with the first roller 9; such configuration occurs in correspondence with an interception of the front free edge 2a of the film 2 by the base 4b of the aforesaid group 4 of products 5 during the transit of the group itself in proximity of the aforesaid slot 8.

This waiting configuration of the rollers 9 and 10 allows a pre-determined quantity of film 2 to unreel towards the transport plane 3 through the free passage channel defined by the first facet 13.

Subsequently the rollers 9 and 10 are activated, as visible in Figure 3 and indicated by the arrow F on the roller 9, in counter-rotation and at least at a first speed V_1 sufficient to define the cut of the film 2 in correspondence with a free rear edge 2b, thus obtaining the aforesaid section S.

Lastly, there is a further rotation of the rollers 9 and 10, indicated by the arrow F1 in Figure 3, in order to feed a subsequent free edge 2a in correspondence with the slot 8.

The number 15 indicates in Figures 1 and 2 means for holding the film 2 acting thereupon to maintain it in contact with the second roller 10 during the cutting operation on the film 2 defining the previous section S.

More in detail, the aforesaid holding means 15 comprise a third roller 16, motor driven and in phase with the aforesaid rollers 9 and 10 thanks to the connection with the aforesaid motor 14m by means of a related pulley 16p. The third roller rotates around a related axis Y" parallel and below the axes Y and Y' of rotation of the rollers 9 and 10 with respect to the transport plane 3. This third roller 16, presenting a rubber-covered cylindrical surface 16s, is in tangential contact, in a second point indicated as P2, with the second roller 10. Such third roller 16, moreover, presents a second plane facet 17 on its own outer circumference positioned in proximity of a second point of tangential contact P2 when the two aforesaid rollers 9 and 10 are in the aforesaid waiting configuration: in this way the film 2 can pass freely also in correspondence with this point of tangency P2, while, simultaneously with the cutting activation of the rollers 9 and 10, the third roller 16 affects a rotation such as to maintain the contact between the film 2 as it advances and the second roller 10, preventing its return towards the aforesaid reel due to the detachment of the film 2 from the section S just defined.

The number 18 in Figure 2 indicates means able to generate a vacuum, which are obtained on the second roller 10 and act only on a part of the outer circumference of the second roller 10.

Such means 18 hold the aforesaid subsequent free edge 2a of the film 2 on the second roller 10, when the edge itself must move beyond the pair of rollers 9 and 10 immediately after the previous section S has been cut: the holding action is necessary since the high speeds involved, coupled with an electrostatic charge inherent in the characteristics of the plastic film 2 could cause the film itself to deviate towards the first roller 9.

More specifically, such vacuum generating means 18 can comprise a longitudinal air intake duct 19, inside the second roller 10, and connected to a plurality of radial ducts 20 parallel to each other and leading only onto an area of the outer cylindrical surface of the second roller 10; the subsequent free front edge 2a is detached from the second roller 10 by a fixed guiding wall 21 positioned between the second roller itself and the slot 8 (see Figure 2). Note that, from the construction standpoint, the second roller 10 presents a circumferential distance, i.e. the one not presenting the aforesaid first facet 13, equal to the distance D which lies between the first point of tangency P1 and the slot 8: in this way it is possible, with a round angle, to bring the subsequent free front edge 2a from the first point of tangency P1 to the slot 8 to be intercepted by the subsequent group 4 of products 5.

Observing Figure 1, the wrapping station 6 is provided with wrapping means 30, comprising a plurality of equidistant bars 31 and driven by a pair of chains closed in a loop and passing over a bridge frame 33 positioned above the transport plane 3.

Each bar 31 intercepts the film 2 passing beyond the slot 8 (upstream) and subsequently to the passage of the group 4 of products 5 beyond the same slot. The bar 31 allows a related unreeling at altitude of the film 2 to go beyond the group 4 of products 5, since the bars 31 move at a speed V_t higher than the speed of advance V_a of the groups 4, and such as to allow the group 4 to be wrapped along the direction of advance A with the section S of film 2.

To effect the aforesaid cut of the film 2 in the section S to measure, the two rollers 9 and 10 must present the aforesaid tangential cutting velocity V_1 higher than the speed of advance V_t of the bars 31 in order to obtain the aforesaid cutting rotation in correspondence with the unreeling of the film 2 at altitude by means of bars 31.

Clearly the first and the second roller 9 and 10 present the aforesaid first tangential cutting velocity V_1 higher than the aforesaid feeding speed V_a , while in the rotation for feeding the film 2, subsequent to the cut, the rollers 9 and 10 present a second velocity V_2 essentially equal to the feeding speed V_a of the group 4 of products 5: in this way, the rear free edge 2b just cut is distanced from the subsequent front free edge 2a, whilst at the same time the latter is advanced in phase with the group

4 of products 5 which is due to intercept it, preventing overlaps with the previous section S.

From this summary description, the subject device fully attains its set goals, thanks to a compact structure whose minimal size derives from the use of only three rollers for all film feeding and cutting phases.

The sequence of phases which determines the steady-state operation of the device allows an extremely flexible adjustment of the device itself, thanks to which it is possible to change a format in a very short time, simply adjusting the activation times of the roller cut according to the length of the film to be fed.

This extreme flexibility enables the device to be mounted on any type of packaging machine, whether the machine is destined to applications wherein the packaging rate of groups of products per unit of time is medium - high or medium - low, since the structure of the device itself allows a high operating rate at steady state regardless of the type of operation of the product packaging stations.

All this without the device weighing excessively on the construction costs of the machine in its entirety.

The invention thus conceived can be subject to numerous modifications and variations, without thereby departing from the scope of the inventive concept. Moreover, all components may be replaced with technically equivalent elements.

30 Claims

1. Device for feeding and cutting film in machines for packaging products, machines comprising a station (1) for feeding film made of plastic material (2) from a continuous reel in phase with said machine; said feeding station (1) being positioned essentially underneath a plane (3) for the transport of groups (4) of products (5), with horizontal direction of advance (A) at feeding speed (V_a), feeding a wrapping station (6); said feeding station (1) being also provided with cutting means (7) able to allow the definition of a section (S) of predefined length of said film (2), in phase with said machine, and developing transversely to the machine itself; a free front edge (2a) of said film (2) being interceptable by the base (4b) of said group (4) of products (5) in correspondence with their transit in proximity of a pass-through slot (8) present on said transport plane (3), and so as to allow said film (2) to unreel on the same plane underneath said group (4), characterised in that it comprises said cutting means (7) formed by at least a pair of rollers (9, 10) counter-rotating around respective parallel axes (Y, Y'), positioned in proximity of said slot (8), and to which is interposed, in correspondence with a first point of tangential contact (P1), said film (2); said first roller (9) being provided with a knife (11) protruding radially therefrom; said second roller (10) being provided with a radial throat

(12) housing part of said knife (11), in correspondence with a reciprocal cutting counter rotation, and with a first plane facet (13) obtained on its surface downstream from said throat (12) with respect to the direction of rotation (S1) of said second roller (10), said first facet (13) being able to define a channel for the free passage of said film (2); adjustable means (14) for imparting motion to said rollers (9, 10) being provided, acting thereon and able to allow, in succession:

- an arrest in the rotation of said rollers (9, 10) in a waiting configuration such as to position said first facet (13) in proximity of said first point (P1) of tangential contact with said first roller (9), in correspondence with said interception of said free edge (2a), in such a way as to allow the unreeling of a predetermined quantity of said film (2) towards said transport plane (3) through said free passage channel;
- an activation of said rollers (9, 10) in counter rotation at least at a first tangential speed (V1) sufficient to define a cut of said film (2) in correspondence with the rear free edge (2b) and so as to obtain said section (S);
- a rotation of said roller (9, 10) through a round angle to return to said waiting configuration so as to feed a subsequent free edge (2a) in correspondence with said slot (8);

holding means (15) being provided, acting on said film (2) and able to allow the film itself to remain in contact with said second roller (10) at least in correspondence with said cut of said film (2).

2. Device according to claim 1, characterised in that said holding means (15) comprise a third motor driven roller (16), in phase with said rollers (9, 10) and rotating around a related axis (Y") parallel to and lower than said axes (Y, Y') of rotation of said first and second roller (9, 10) with respect to said transport plane (3); said third roller (16) being in tangential contact, in a second point (P2), with said second roller (10); said third roller (16) presenting at least a second facet (17) on its own outer circumference positioned in proximity of said second point of tangential contact (P2) in correspondence with said arrest of said rollers (9, 10), so as to allow the free passage of said film (2), said third roller (16) being movable in phase with said rollers (9, 10) in correspondence with said cutting activation so as to maintain said film (2), as it advances, in contact with said second roller (10).
3. Device according to claim 1, characterised in that said second roller (10) presents a circumferential distance, i.e. the one not presenting said first facet (13), equal to the distance (D) between said first

point of tangency (P1) and said slot (8).

4. Device according to claim 1, characterised in that said second roller (10) is provided with means (18) able to generate a vacuum in correspondence with a part of its own outer circumference and able to hold said subsequent free edge (2a) of said film (2) onto the second roller itself in correspondence with said first cutting activation.
5. Device according to claim 4, characterised in that said vacuum generation means (18) comprise at least one longitudinal duct (19) for air aspiration, internal to said second roller (10), and connected to a plurality of radial ducts (20) leading to the outer cylindrical surface of said second roller (10).
6. Device according to claim 1, characterised in that said first and second roller (9, 10) present a first cutting tangential velocity (V1) preferentially higher than said feeding speed (Va).
7. Device according to claim 1, wherein are provided wrapping means (30) comprising a plurality of cross bars (31) equidistant and driven by a pair of chains closed in a loop and passing over a bridge frame (33) positioned above said transport plane (3); said cross bars (31) acting on said film (2) so as to allow the film itself to be intercepted by means of a passage of said cross bar (31) beyond said slot (8), subsequently to the passage of said group (4) of products (5) beyond the slot itself, and a related unreeling at altitude of said film (2); said cross bars (31) moving at a speed (Vt) higher than said speed of advance (Va) of said groups (4) so as to allow a wrapping of said group (4) of products (5) along said direction of advance (A) with said section (S) of film (2), characterised in that said first and second roller (9, 10) present said first cutting tangential velocity (V1) preferentially higher than said speed of advance (Vt) of said cross bars (31) so as to perform said cutting rotation in correspondence with said unreeling at altitude of said film (2) and so as to define said section (S).
8. Device according to claim 1, characterised in that said first and second roller (9, 10) present a second speed (V2), in correspondence with said rotation of the same rollers feeding said film (2) towards said slot (8), essentially equal to said feeding speed (Va) of said group (4) of products (5).

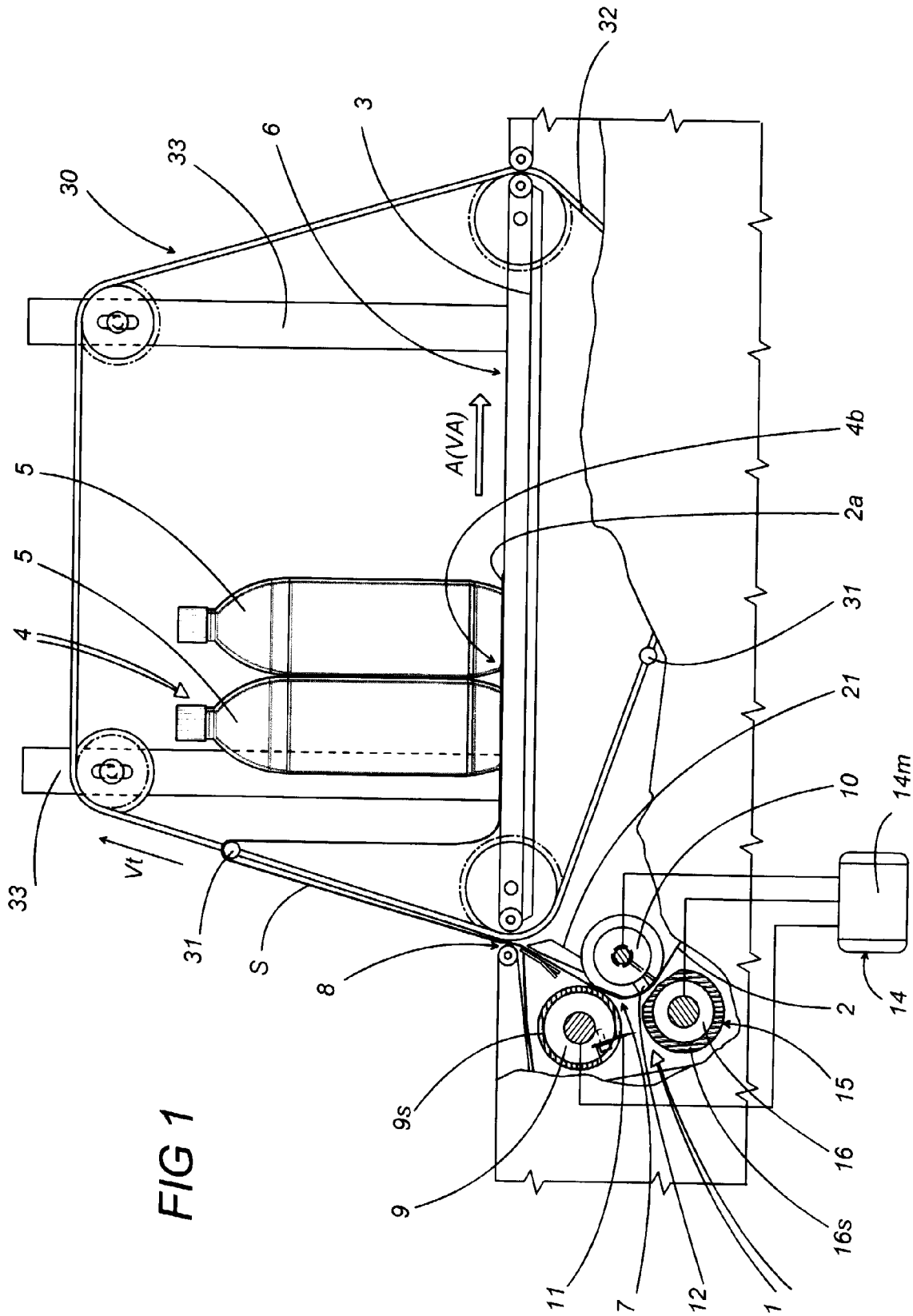

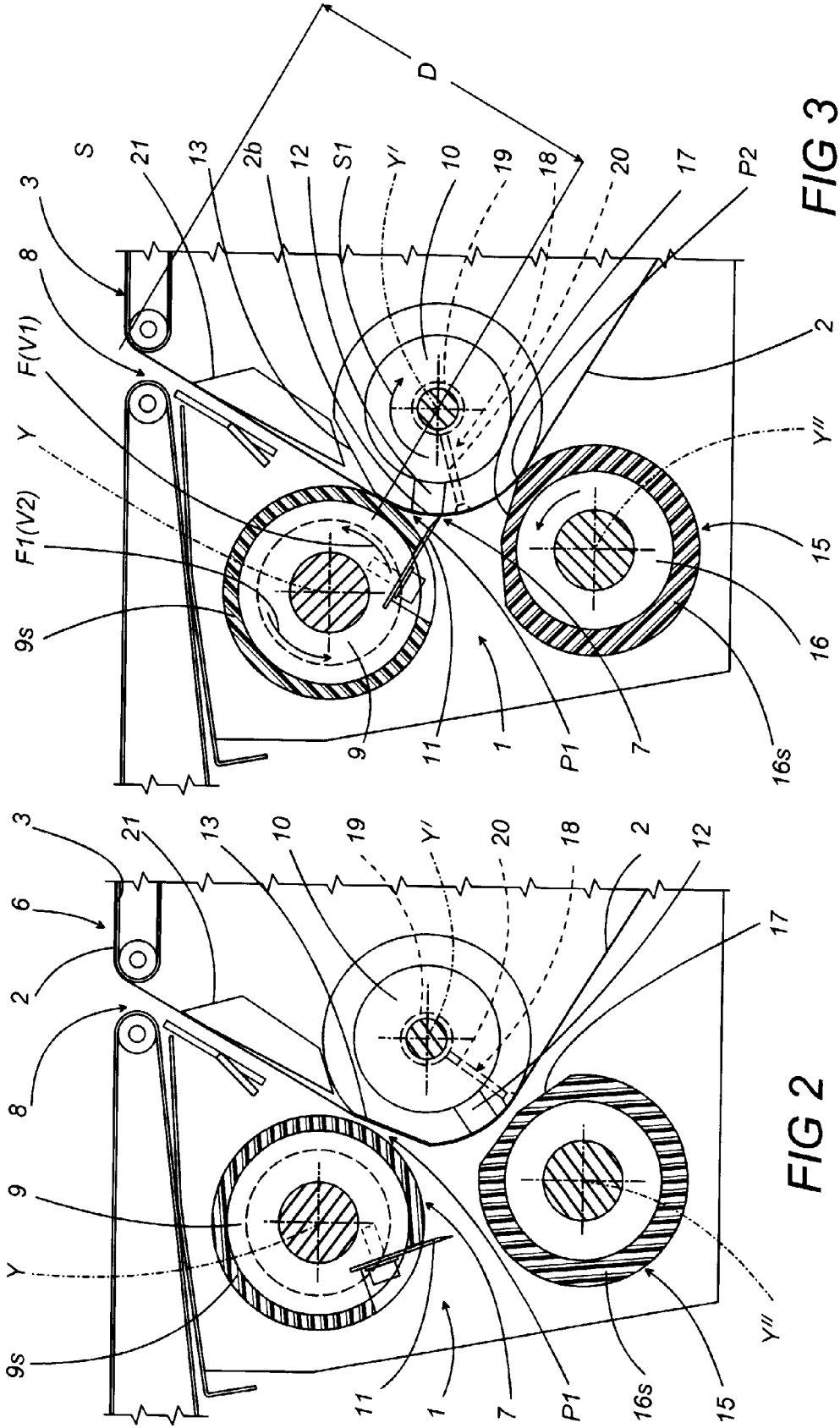
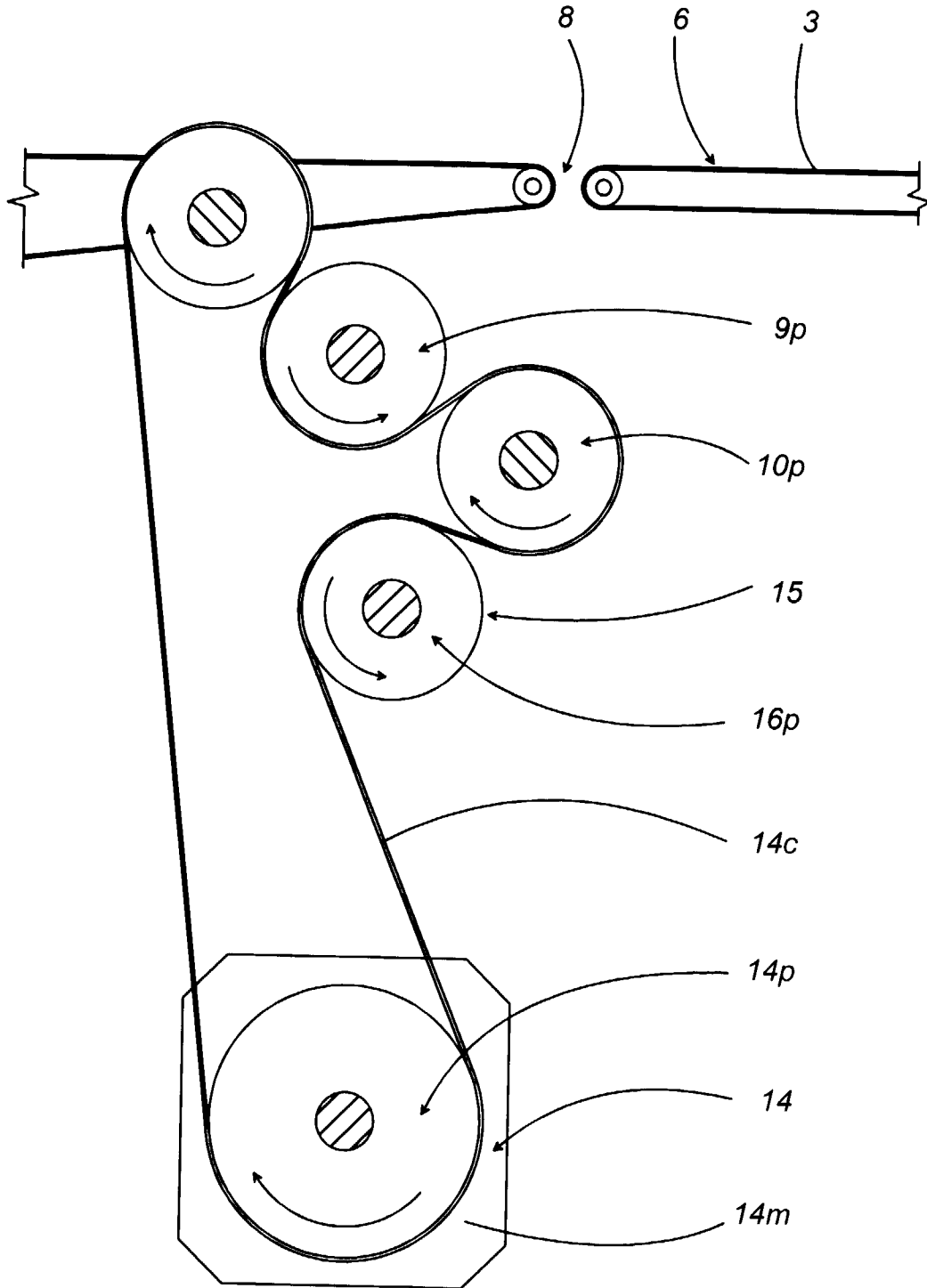

FIG 3

FIG 2

FIG 4





European Patent Office

EUROPEAN SEARCH REPORT

Application Number
EP 97 83 0541

DOCUMENTS CONSIDERED TO BE RELEVANT			
Category	Citation of document with indication, where appropriate, of relevant passages	Relevant to claim	CLASSIFICATION OF THE APPLICATION (Int.Cl.6)
A	GB 2 255 952 A (BAUMER SRL) * abstract *	1,7,8	B65B61/08 B65B11/10 B26D1/40 B26D7/14
A	--- PATENT ABSTRACTS OF JAPAN vol. 017, no. 358 (M-1440), 7 July 1993 & JP 05 051018 A (IBARAKI SEIKI KK), 2 March 1993, * abstract *	1,7,8	
A	--- EP 0 573 944 A (GD SPA) * column 3, line 10 - line 54; figure 1 *	1,4,5	
D,A	--- EP 0 491 666 A (DIMAC SPA) * abstract *	1,6	
A	--- EP 0 707 928 A (ASAHI TEKKOSHO KK) * column 4, line 13 - column 6, line 30; figures 1,2,8-13 *	1,2	
			TECHNICAL FIELDS SEARCHED (Int.Cl.6)
			B65B B26D B65H
The present search report has been drawn up for all claims			
Place of search		Date of completion of the search	Examiner
BERLIN		22 January 1998	Béraud, F
CATEGORY OF CITED DOCUMENTS		T : theory or principle underlying the invention E : earlier patent document, but published on, or after the filing date D : document cited in the application L : document cited for other reasons & : member of the same patent family, corresponding document	
X : particularly relevant if taken alone Y : particularly relevant if combined with another document of the same category A : technological background O : non-written disclosure P : intermediate document			

EPO FORM 1503 03.82 (P04C01)