

No. 858,577.

PATENTED JULY 2, 1907.

H. M. COSEY.  
MUSIC HOLDER AND TURNER.  
APPLICATION FILED FEB. 18, 1907.

Fig. 1.

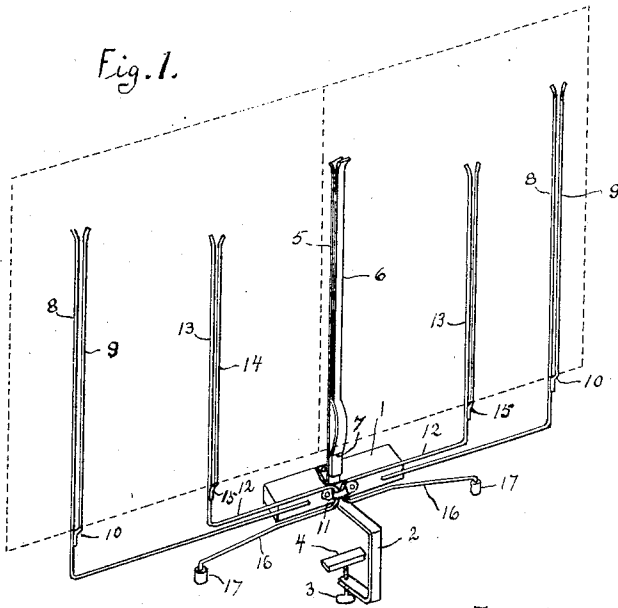
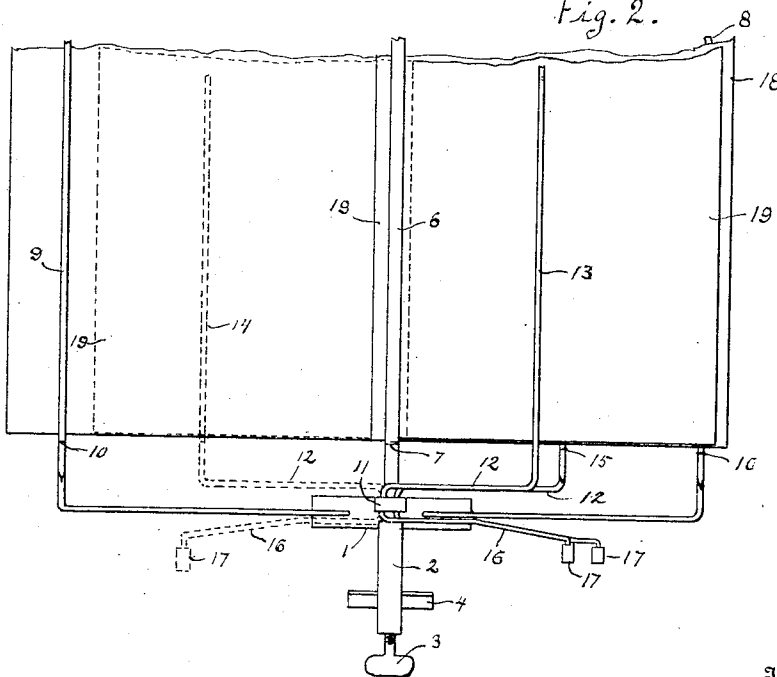

Fig. 2.



Inventor

Henry M. Cosey,

By

Walter N. Haskell,

his Attorney.

Witnesses

Millard Haskell  
Andrew Habera

# UNITED STATES PATENT OFFICE.

HENRY M. COSEY, OF STERLING, ILLINOIS, ASSIGNOR OF ONE-HALF TO SAMUEL WETZELL,  
OF STERLING, ILLINOIS.

## MUSIC HOLDER AND TURNER.

No. 858,577.

Specification of Letters Patent.

Patented July 2, 1907.

Application filed February 18, 1907. Serial No. 357,944.

*To all whom it may concern:*

Be it known that I, HENRY M. COSEY, a citizen of the United States, residing at Sterling, in the county of Whiteside and State of Illinois, have invented certain new and useful Improvements in Music Holders and Turners; and I do declare the following to be a full, clear, and exact description of the invention, such as will enable others skilled in the art to which it appertains to make and use the same, reference being had to the accompanying drawings, and to the letters and figures of reference marked thereon, which form a part of this specification.

My invention has reference to music holders and turners, and aims to provide a simple and novel device of that class wherein the sheets of music will be supported at a uniform height, and capable of being quickly turned in either direction.

The invention is also specially adapted to holding and turning single sheets of music.

The construction, combination and operation of the parts of my invention are as hereinafter set forth and claimed.

In the drawings: Figure 1 shows my invention, in perspective, and Fig. 2 is a front elevation thereof, with sheets of music in place therein, some of the upper portion being broken away.

1 is a block, adapted to be secured to the shelf of a music rack by means of a clamp 2, fixed to the block 1, and provided with a thumb-screw 3, on the upper end of which is loosely held a bar 4, adapted to bear against the lower face of the music shelf.

Fixed in the block 1 is a central support, comprising a vertical bar 5, and spring arm 6, engaging such bar throughout the greater part of its length, and united therewith at its lower end by a bend or seat 7. Two stationary side supports are provided, one on each side of the central support, and each comprising a rear arm or fork 8, and a front arm 9, united with the arm 8 at its lower end by a bend or seat 10.

Pivoted in a bearing 11 on the front face of the block 1 is a pair of arms 12, integral with the outer ends of which are arms or forks 13, secured to which at their lower ends are arms 14, by means of bends or seats 15. Each of the arms 12 is provided with a lever 16, on which is a handle 17, by means of which the arms 12 can be turned from one side of the device to the other.

The central support for the music is preferably formed of metal strips, but the side supports and movable supports are of wire of suitable material and design.

In Fig. 2 the cover or back of a sheet of music is represented by 18, and 19 is a single, loose sheet of music supported by the device. The cover is held by the central and side supports, the bar 5 and arms 8 being in rear thereof, and arms 6 and 9 in front, with the lower edge of the cover supported on the seats 7 and 10. The sheet 19 is held near its inner edge by the central support, and near its central part by one of the movable supports, the lower edge of such sheet resting in the seat 7 and one of the seats 15. The seat 7 of the central support, seats 10 of the side supports, and seats 15 of the movable supports are in horizontal alinement, by which means the cover 18 and various sheets of music are held at a uniform height in the device. The music which is held in the central support is tightly embraced by the arms thereof, the bar 5 and arm 6 being formed of strips of metal, as before mentioned, in order that a greater amount of surface may be provided for holding the sheets, and prevent the same from slipping from the supports. This is especially desirable in the case of single sheets, which are held near one of their edges. In placing the music in the holder the cover and such other sheets as may be desired are first placed in position in the stationary supports. The leaves which are to be turned are then secured in the central support, and are further engaged by one of the movable supports, by being inserted between the arms 13 and 14 thereof. When it is desired to turn the sheet, this is accomplished in the usual manner by throwing the lever 16 which controls such support to one side or the other, as desired. In the turning of the loose sheet, one edge thereof will be folded upon the arm 6 of the central support, as shown in dotted lines in Fig. 2.

The device can be constructed with any desired number of the movable supports, the levers controlling the same being formed in varying lengths so that they will not interfere with each other. The lengths of the arms 12 can also be similarly varied, if desired.

What I claim as my invention, and desire to secure by Letters Patent of the United States, is:

A leaf turner comprising a block, means for clamping the same to the music shelf, a bar extending vertically from the center of the upper face of the block, a strip spring arm secured at its lower end to the said bar and between which arm and bar the fold of the music sheet or sheets is engaged, a pair of stationary arms secured to the front edge of opposite ends of the block and extending outwardly therefrom, said stationary arms being bent upwardly at right angles, spring arms secured at their lower ends to the stationary arms and between which stationary arms and spring arms the back of the music sheet is en-

gaged, a bearing secured to the center of the front edge of the block, a plurality of leaf turning arms each comprising a wire doubled upon itself to form two spaced arms one above the other, said last named arms each being  
5 journaled in said bearing at the point of fold or bend, the lower of the spaced arms being bent downwardly at right angles and provided with a handle, the upper of the spaced arms being bent upwardly at right angles, and spring arms secured at their lower ends to said last mentioned up-

wardly bent arms to engage the music sheets, the points of connection between said upwardly or vertically extending bars and arms being in horizontal alinement. 10

In testimony whereof, I affix my signature, in presence of two witnesses.

HENRY M. COSEY.

Witnesses:

R. W. E. MITCHELL,  
A. M. CLAVIN.