

J. C. STRAUSS.

MAN'S GARMENT.

APPLICATION FILED JULY 13, 1910.

1,052,765.

Patented Feb. 11, 1913.

2 SHEETS—SHEET 1.

Fig. 1.

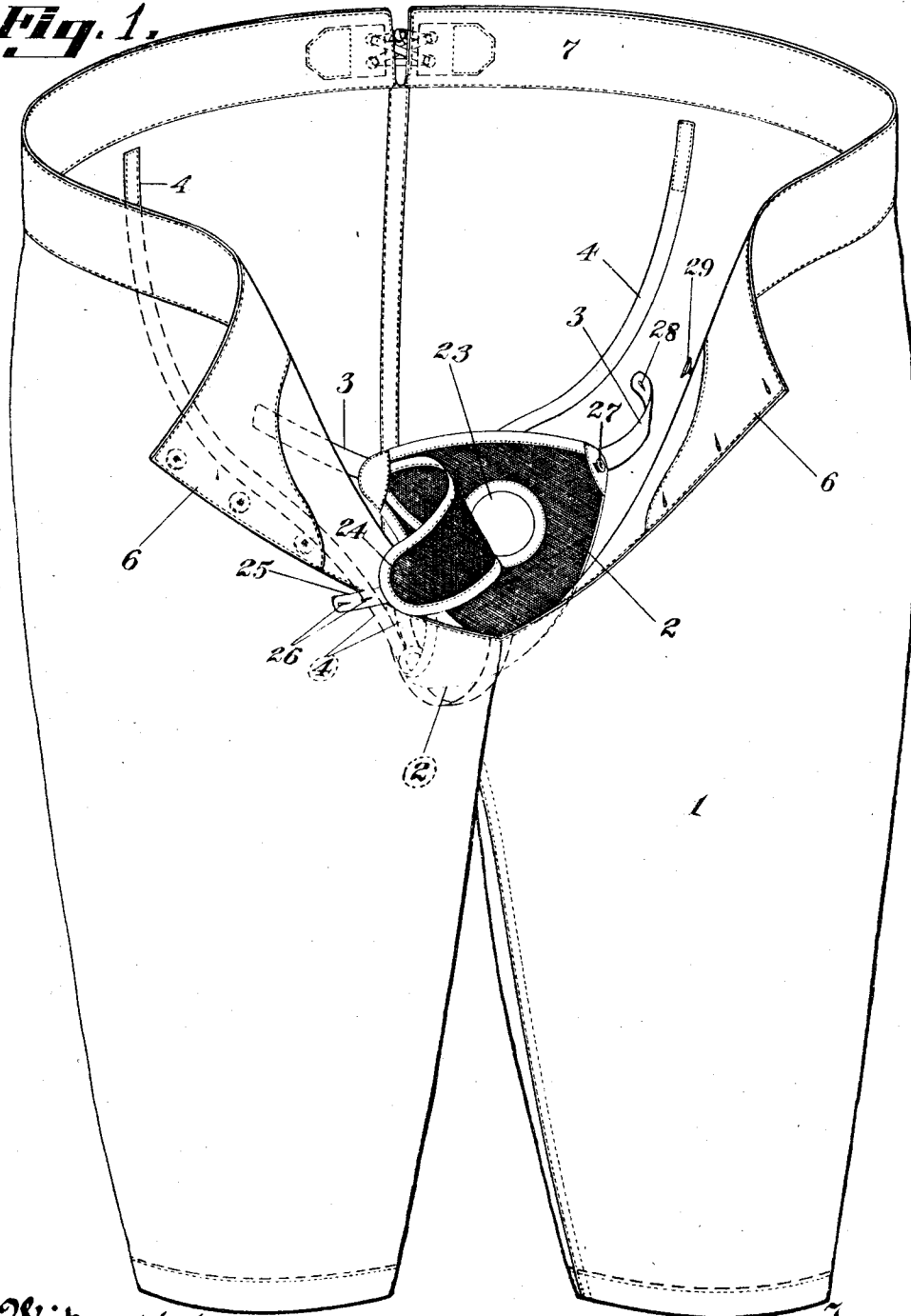

Witnesses:
George G. Anderson.
Thos. R. Koenig.

Inventor:
Julius C. Strauss,
By Hugh W. Wagner
His Attorney.

Fig. 2.

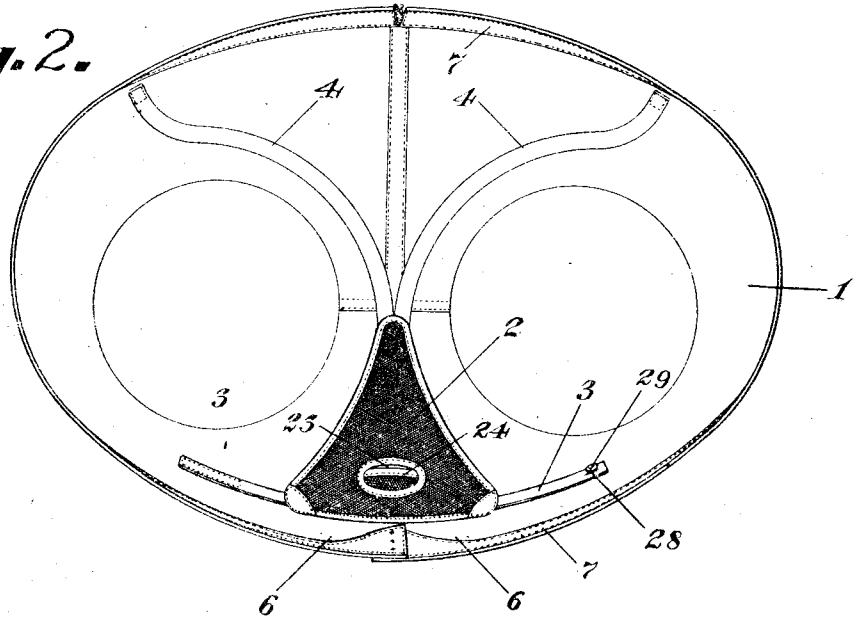
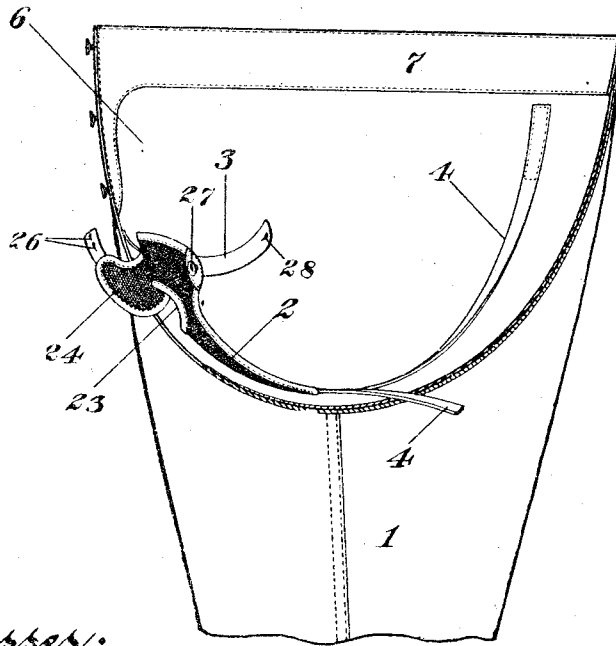

Fig. 3.



Witnesses:

George G. Anderson.
Geo. R. Rooney.

Inventor:

Julius C. Strauss,
By Hugh W. Wagner,
His Attorney.

UNITED STATES PATENT OFFICE.

JULIUS C. STRAUSS, OF ST. LOUIS, MISSOURI.

MAN'S GARMENT.

1,052,765.

Specification of Letters Patent. Patented Feb. 11, 1913.

Application filed July 13, 1910. Serial No. 571,673.

To all whom it may concern:

Be it known that I, JULIUS C. STRAUSS, a citizen of the United States, residing at the city of St. Louis, State of Missouri, have
5 invented certain new and useful Improvements in Men's Garments, of which the following is a specification, reference being had therein to the accompanying drawings.

Suspensories are worn mostly by athletes,
10 gymnasts, ball players, horseback riders, etc., when they are taking their particular kind of exercise. The bag of the suspensory is supported from a belt that extends around the waist of the wearer, but, as is often the
15 case, the belt slips downwardly and not only allows the bag to sag too low to be beneficial to the testicles, but becomes very uncomfortable to the wearer.

It is the object of the present invention to
20 provide a garment in which efficient means for supporting the testicles of the wearer is arranged so that the above-mentioned objectionable features are obviated.

The garment is particularly intended to
25 be worn as an undergarment by every man, and affords a means for supporting the testicles of the wearer at all times.

In the accompanying drawings forming
30 part of this specification, like numbers of reference denote like parts wherever they occur, and Figure 1 is a perspective view of a garment embodying this invention; Fig. 2 is a top plan view of the same; and Fig. 3 is a vertical sectional view.

35 While a pair of drawers 1 that may be of any length or style is depicted in the drawings to illustrate this invention, yet it should be understood that a union suit can be substituted therefor without departing
40 from the spirit of this invention.

The bag or sack 2, which is designed to support the testicles of the wearer, is preferably formed of material that is soft and strong, and, if desired, can be made of the
45 same kind of material of which the garment is made. The front part of the bag is preferably supported by means of a pair of straps 3, and the rear part of the bag is supported by means of a pair of straps 4, each

of said straps being formed of tape, elastic, 50 or any other suitable material. The bag 2 may be flat and somewhat triangular in shape, and be provided with an opening 23. The penis of the wearer extends through said opening and rests in a hammocklike
55 strip 24 that is located on the front side of bag 2. One end of strip 24 is secured by any suitable means to one of the upper corners of bag 2, and the other end of said strip bears a strap 25 in which button-holes 26
60 are formed to attach same to a button 27 that is fastened to the other upper corner of said bag. In this form of the invention the front straps 3 and the rear straps 4 are preferably formed of elastic. One of the
65 front straps 3 is fastened to an upper corner of bag 2 and is sewn to one of the halves 6 of the garment, and the other strap 3 is fastened to the other upper corner of bag 2 and is provided with button-hole 28, which
70 affords a means for attaching same to a button 29 that is secured to the other half 6 of the garment. The lower ends of each rear strap 4 are fastened to the back corner of bag 2 and the upper ends of said straps
75 are sewn to the waist of the garment.

I claim:

In combination with a pair of drawers, a bag located at the front opening of the drawers, a short elastic substantially horizontal 80 strap secured at one end to the top side of the bag at one end of the latter, the opposite end of said strap being sewed to the adjacent leg of the drawers, a similar short elastic substantially horizontal strap secured at one end to the top side of the bag 85 at the opposite end of the latter, the opposite end of the last mentioned strap having a button hole, a button on the other drawer leg to be received in said button-hole, the 90 sides of the bag converging rearwardly, and a pair of long elastic straps each connected at one end in side by side contacting relation to the rear end of said bag, the opposite ends of said long straps being sewed to 95 the adjacent respective drawer legs at the rear portions of the latter, the said opposite ends of the long straps being attached to the

drawers at points considerably above the points of attachment of the short straps to the drawers and being disposed at points substantially in alinement with the points of attachment of the short straps to the drawers.

In testimony whereof I have hereunto

affixed my signature in the presence of two witnesses.

JULIUS C. STRAUSS.

Witnesses:

L. M. FOX,
IRA R. KOENIG.