

(No Model.)

F. M. LUCAS.
CHURN DASHER.

No. 493,828.

Patented Mar. 21, 1893.

Fig. 1.

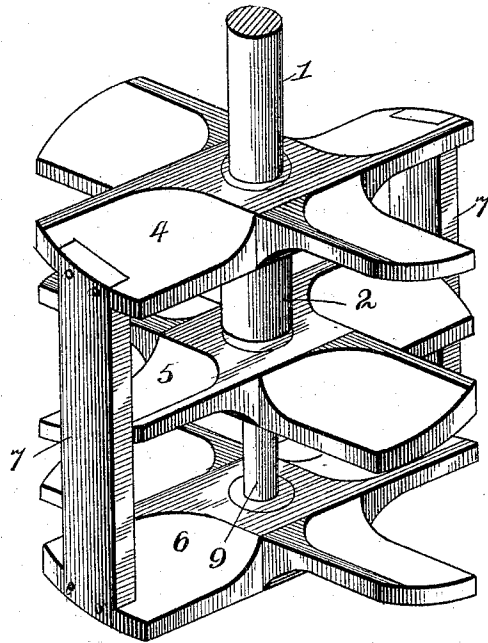
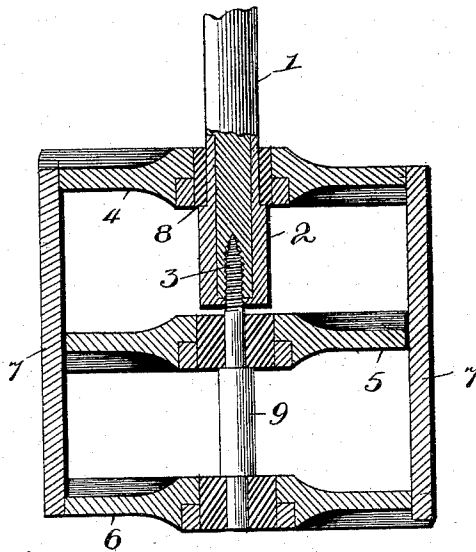

Fig. 2.



Witnesses

John Shaw
W. H. Riley

Inventor

By *his* Attorneys, *Francis M. Lucas.*

C. A. Snow & Co.

UNITED STATES PATENT OFFICE.

FRANCIS M. LUCAS, OF ESKRIDGE, KANSAS.

CHURN-DASHER.

SPECIFICATION forming part of Letters Patent No. 493,828, dated March 21, 1893.

Application filed January 10, 1893. Serial No. 457,922. (No model.)

To all whom it may concern:

Be it known that I, FRANCIS M. LUCAS, a citizen of the United States, residing at Eskridge, in the county of Wabaunsee and State of Kansas, have invented a new and useful Churn-Dasher, of which the following is a specification.

The invention relates to improvements in churn dashers.

The object of the present invention is to improve the construction and increase the efficiency of churn dashers, and to provide one which will rapidly produce butter without throwing the milk in a spray against the sides of a churn body.

The invention consists in the construction and novel combination and arrangement of parts hereinafter fully described, illustrated in the accompanying drawings and pointed out in the claim hereto appended.

In the drawings—Figure 1 is a perspective view of a churn dasher constructed in accordance with this invention. Fig. 2 is a vertical sectional view.

Like numerals of reference indicate corresponding parts in both the figures of the drawings.

1 designates a dasher-rod provided at its lower end with a cylindrical journal 2, having a socket in its lower end and receiving a screw 3; and arranged on the journal and the screw, are a top, a bottom and an intermediate dasher 4, 5 and 6. The top, bottom and intermediate dashers 4, 5 and 6, each consist of cross-blades disposed at right angles to each other and having their ends set at an inclination to form propelling blades, whereby when the dashers are reciprocated vertically they will be rotated. The intermediate dasher has its inclined blades arranged the reverse of the top and bottom dashers, whereby it will be rotated in the opposite direction from the rotation of the top and bottom dashers; and the latter are connected at diametrically opposite points by vertical bars 7, which are rigidly secured to the ends of dasher blades. Each of the dashers is provided with

a metal bushing; and the journal 2, which receives the top dasher, is provided with an annular shoulder 8, formed by reducing the upper portion of the journal. The screw 3 has its ends reduced to form journal portions, and the ends of the intermediate portion 9 form shoulders against which the intermediate and bottom dashers bear. The intermediate or central dasher is arranged between the lower end of the socket and the upper terminus or shoulder of the portion 9 of the screw.

It will be seen that the dasher mechanism is simple, comparatively inexpensive and efficient, and that it is adapted to produce butter rapidly without throwing the milk into a spray.

Changes in the form, proportion and the minor details of construction may be resorted to without departing from the principle or sacrificing any of the advantages of this invention.

What I claim is—

The combination of a dasher rod, a journal secured to the lower end of the same and having its upper portion reduced to form a shoulder and provided in its lower end with a socket, a screw having its upper end secured in the socket and having reduced journal portions at its ends forming an intermediate portion and providing shoulders, the top and bottom dashers composed of propelling blades and arranged on the journal and the lower end of the screw, the opposite vertical bars secured to the ends of dasher blades of the top and bottom dashers and rigidly connecting the latter, and the intermediate dasher arranged on the upper journal portion of the screw and having its propelling blades arranged the reverse of those of the other dashers, substantially as and for the purpose described.

In testimony that I claim the foregoing as my own I have hereto affixed my signature in the presence of two witnesses.

FRANCIS M. LUCAS.

Witnesses:

J. J. MITCHELL,
E. SHEPHERD.