



US 20070240257A1

(19) **United States**

(12) **Patent Application Publication**  
**Ignarra et al.**

(10) **Pub. No.: US 2007/0240257 A1**

(43) **Pub. Date: Oct. 18, 2007**

(54) **TELEVISION LIFT DEVICE FOR A SPA OR OTHER INDOOR OR OUTDOOR APPLICATIONS**

**Publication Classification**

(51) **Int. Cl.**  
*A47K 3/10* (2006.01)  
*A47K 3/00* (2006.01)  
(52) **U.S. Cl.** ..... 4/541.1

(75) Inventors: **Ricardo Santiago Ignarra**, La Habra Heights, CA (US); **Daniel John Whitaker**, Santa Ana, CA (US)

(57) **ABSTRACT**

A lift device for mounting a TV to a spa or other indoor and outdoor applications. The TV is lifted to a viewing position when in use, and lowered into a retracted position when not in use. The lift device includes an upper housing for housing a flat panel TV, a lower case, a linear actuator and a pair of linear guides mounted on the lower case to provide up and down movements of the TV. The TV and the upper housing are attached to sliding members of the linear guides by a lower mounting bracket. The TV is also attached to the linear actuator by an upper mounting bracket. In one embodiment, the lift device is disposed within a housing attached to the outside of the spa; in another embodiment, the lift device is disposed within a cavity of the shell of the spa.

Correspondence Address:  
**YING CHEN**  
**Chen Yoshimura LLP**  
**255 S. GRAND AVE.**  
**# 215**  
**LOS ANGELES, CA 90012 (US)**

(73) Assignee: **The Accessory Group Inc.**

(21) Appl. No.: **11/406,456**

(22) Filed: **Apr. 18, 2006**

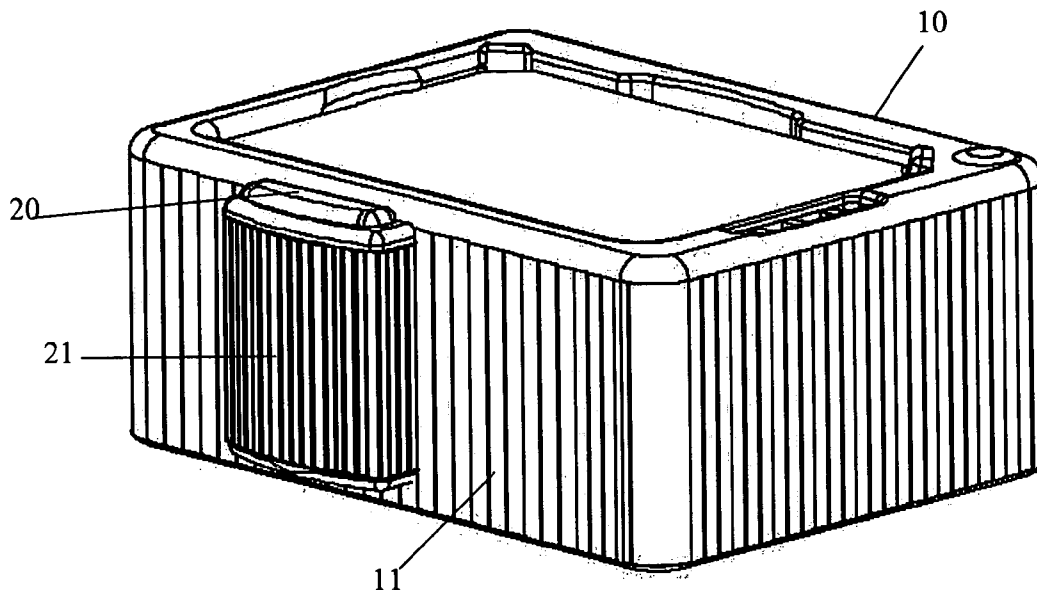

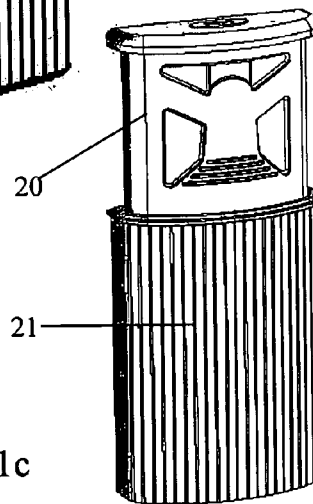
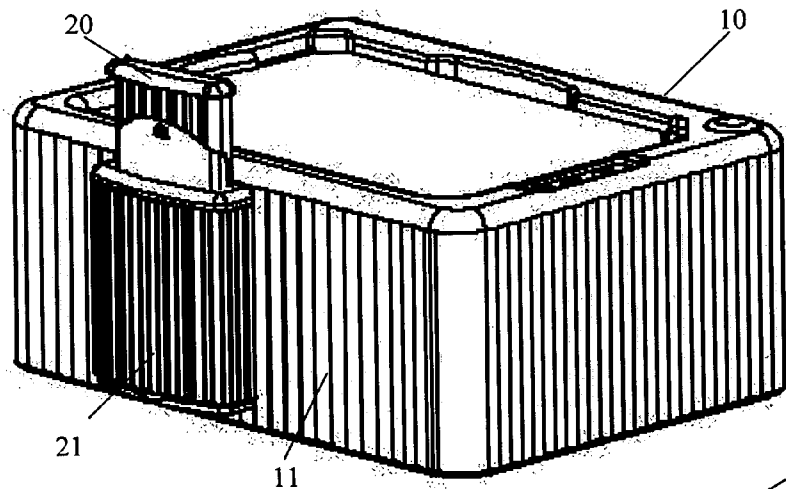
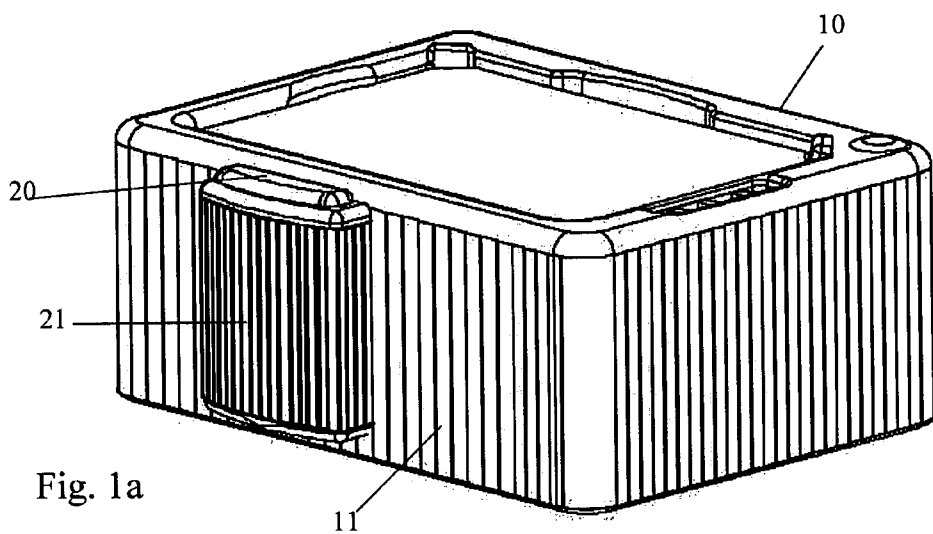

Fig. 1b

Fig. 1c

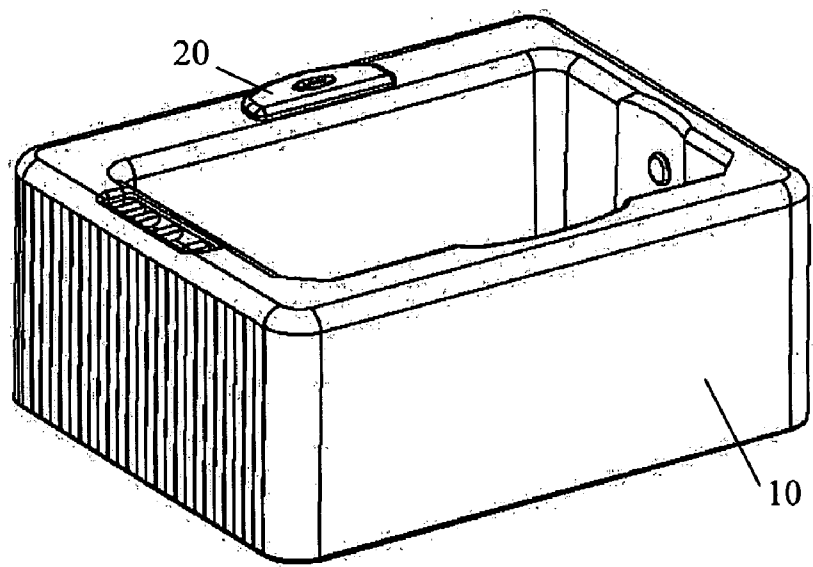

Fig. 2a

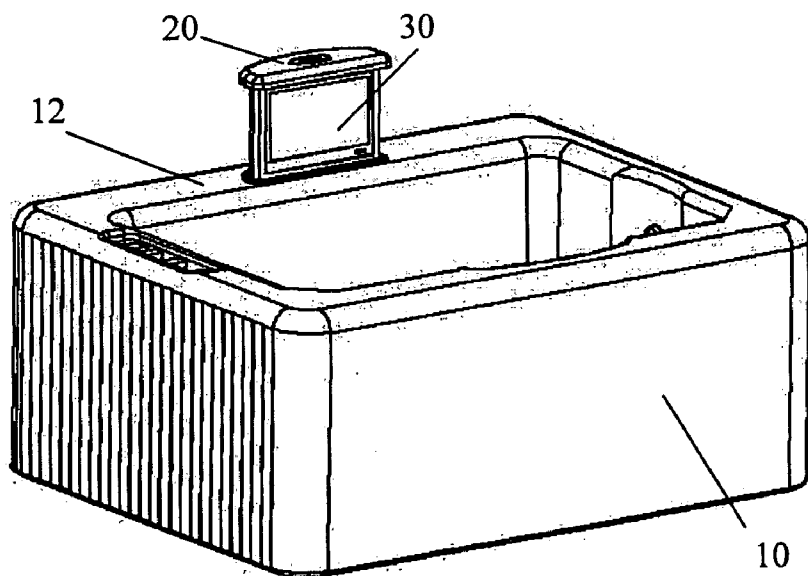

Fig. 2b

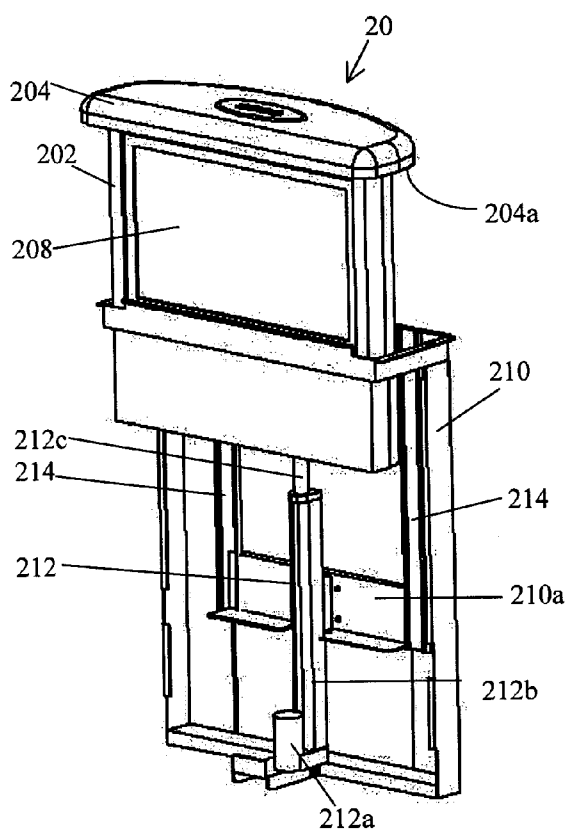

Fig. 3a

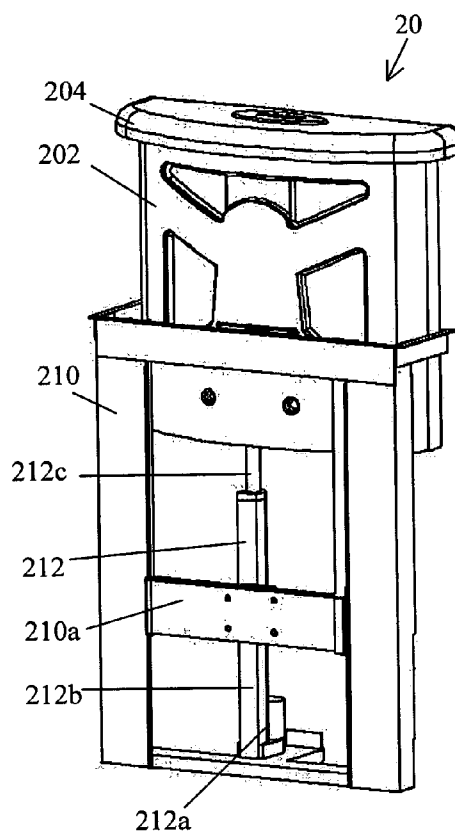

Fig. 3b

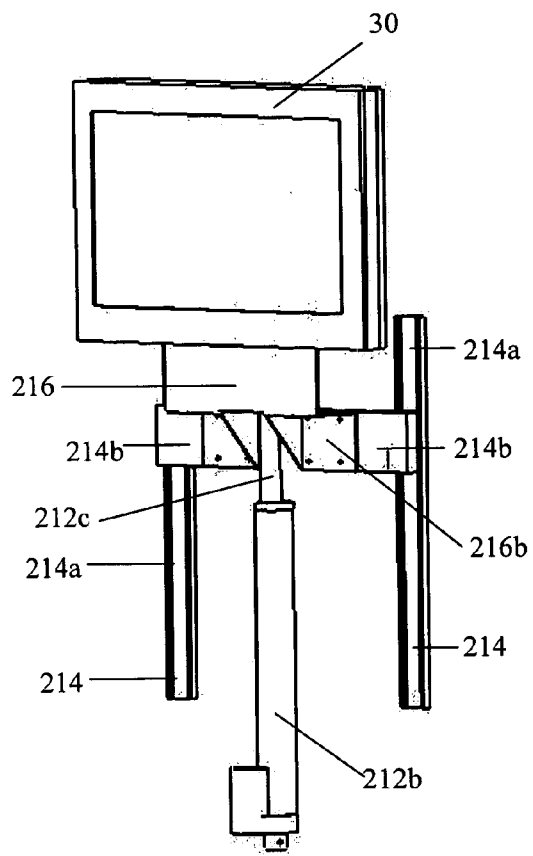

Fig. 4a

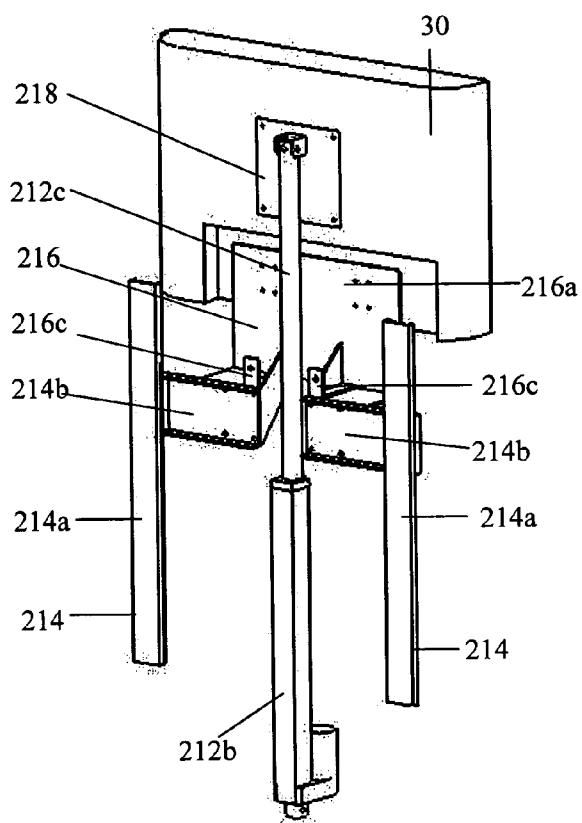

Fig. 4b

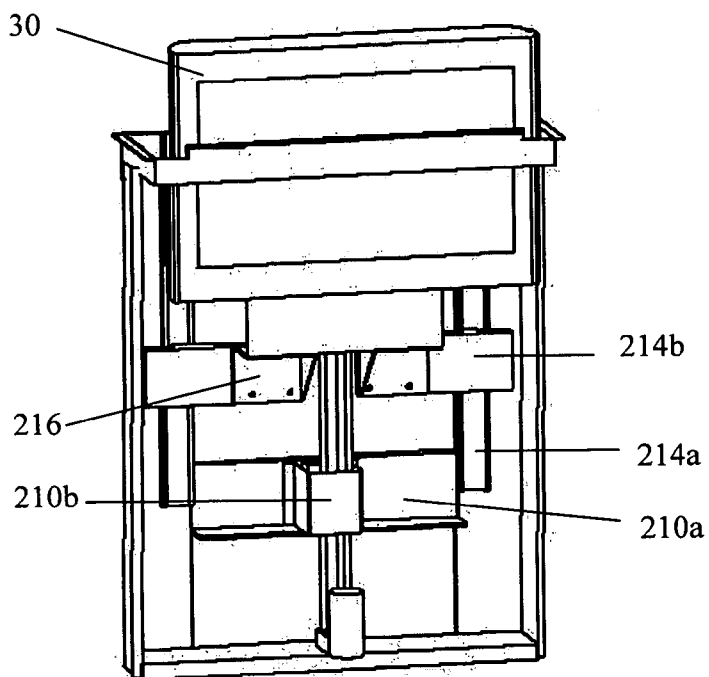

Fig. 5

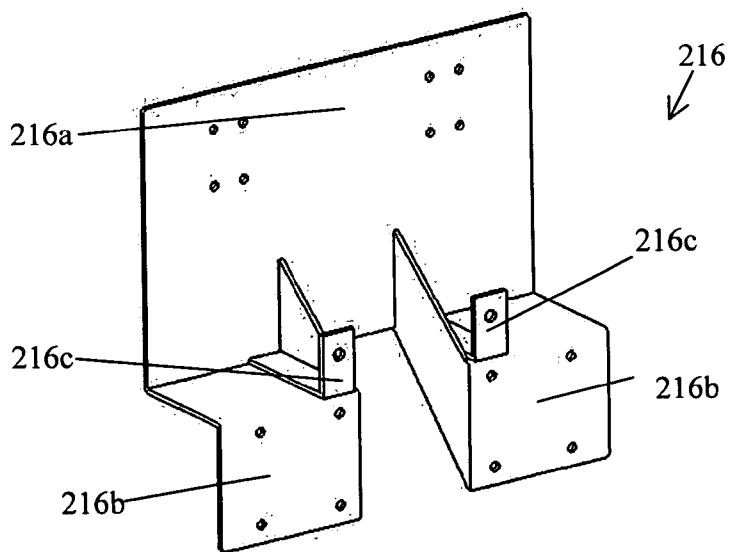

Fig. 6

**TELEVISION LIFT DEVICE FOR A SPA OR OTHER INDOOR OR OUTDOOR APPLICATIONS**

**BACKGROUND OF THE INVENTION**

[0001] 1. Field of the Invention

[0002] This invention relates to a lift device for installing a television in a spa or other indoor or outdoor applications.

[0003] 2. Description of the Related Art

[0004] Spas having a retractable entertainment unit have been described. Examples include the systems described in U.S. Pat. No. 6,754,916 B1 entitled "Spas having a retractable entertainment unit", and U.S. Patent Appl. Pub. No. 2004/0068786 A1 entitled "Combination spa and entertainment system".

**SUMMARY OF THE INVENTION**

[0005] The present invention is directed to an improved TV lift device for a spa.

[0006] An object of the present invention is to provide a TV lift device for a spa that is structurally sturdy and provides smooth upward and downward movement of the TV.

[0007] Another object of the present invention is to provide a TV lift device for a spa that is easy and less costly to install.

[0008] Additional features and advantages of the invention will be set forth in the descriptions that follow and in part will be apparent from the description, or may be learned by practice of the invention. The objectives and other advantages of the invention will be realized and attained by the structure particularly pointed out in the written description and claims thereof as well as the appended drawings.

[0009] To achieve these and other advantages and in accordance with the purpose of the present invention, as embodied and broadly described, the present invention provides a television lift device, which includes: an upper housing having a clear screen for housing a television set; a lower case; a linear actuator mounted vertically on the lower case, the linear actuator including a motor, a body and a shaft that extends from or retracts into the body, wherein an upper end of the shaft is adapted for attaching to the television set; one or more linear guides each including a vertical stationary bar mounted on the lower case and a sliding member engaged with and vertically slideable along the stationary bar; and a mounting bracket having a first portion attached to the sliding members of the linear guides and a second portion adapted for attaching to the television. The lower housing may be disposed within an outer housing attached to an outside of the spa, or disposed within a cavity of a shell of the spa.

[0010] In another aspect, the present invention provides a television lift device, which includes: an outer housing adapted for attaching to an outside surface of an outdoor or indoor application; a lower case disposed within the outer housing; a motor-driven lift structure mounted on the lower case and adapted for attaching to the television set; and an upper housing having a clear screen and attached to the lift structure for housing a television panel.

[0011] It is to be understood that both the foregoing general description and the following detailed description are exemplary and explanatory and are intended to provide further explanation of the invention as claimed.

**BRIEF DESCRIPTION OF THE DRAWINGS**

[0012] FIGS. 1a-1c show a TV lift device according to a first embodiment of the present invention.

[0013] FIGS. 2a and 2b show a TV lift device according to a second embodiment of the present invention.

[0014] FIGS. 3a and 3b are front and rear perspective views, respectively, of a TV lift device according to an embodiment of the present invention.

[0015] FIGS. 4a and 4b are front and rear perspective views, respectively, of portions of the TV lift device shown in FIGS. 3a and 3b.

[0016] FIG. 5 is a front perspective view of the TV lift device shown in FIGS. 3a and 3b in a partially lowered position.

[0017] FIG. 6 illustrates a bracket used in the lift device shown in FIGS. 3a and 3b.

**DETAILED DESCRIPTION OF THE PREFERRED EMBODIMENTS**

[0018] Embodiments of the present invention provide a flat panel TV lift device which holds a flat panel TV and lifts it to a viewing position and lowers it back to stow it in a housing when not in use. The lift device can be used in conjunction with a spa, barbeque island or other outdoor or indoor applications where viewing TV is desirable.

[0019] FIGS. 1a-1c show a TV lift device according to a first embodiment of the present invention. FIG. 1a shows the TV lift device in a lowered position where the TV is retracted into the housing and not visible; FIG. 1b shows the TV lift device in the lifted viewing position. This lift device can be attached to the external side of an outdoor spa (as shown), barbeque island (not shown), etc. FIG. 1c shows the TV lift device unattached to a spa or other equipment. As shown in FIGS. 1a and 1b, the TV lift device 20 and the flat panel TV are disposed inside an outer housing 21 which is attached to an outside surface 11 of the spa 10 by bolts or other suitable attachment structures. The exterior of the outer housing 21 may be made to have the same finishing material or decoration as the exterior of the spa 10 to achieve a custom, integrated appearance. An advantage of locating the lift device and the TV outside of the spa is that it reduces exposure of the electronics to temperature change, humidity, chemicals, and excessive vibrations. For example, in a hot environment, the heat can often build up to over 190 degrees under the tub. Installing the electronics outside the tub provides better environmental conditions for the electronics and reduces the requirement on the quality of the LCD TV, DVD players or other devices installed therein. As a result, less expensive TVs and DVD players can be used. Another advantage of the external mount design is that the spa shell does not need to be modified and no mold changes are required to the existing mold. The lift device can be attached to any spa design. This makes the installation easier and less costly.

[0020] FIGS. 2a and 2b show a TV lift device according to a second embodiment of the present invention. FIG. 2a shows the TV lift device in a lowered position where the TV is retracted into the cavity and not visible; FIG. 2b shows the TV lift device in the lifted viewing position. This lift device is installed within the top shell of a spa and is enclosed by the outer spa decorative material. This device can also be installed in outdoor barbeque island or cabinetry etc. As shown in FIGS. 2a and 2b, the TV lift device 20 and the flat panel TV 30 are disposed inside a cavity provided in a framework 12 of the spa 10 and is integrated into the design of the spa. An advantage of integrating the lift device into the spa shell is that it provides enhanced, built-in appearance.

[0021] FIGS. 3a and 3b illustrate the structure of the TV lift device that can be used in the first or second embodiments. The lift device is shown without the enclosures. When used in the first embodiment shown in FIGS. 1a and 1b, the lift device 20 is disposed in the outer housing 21, while when used in the second embodiment shown in FIGS. 2a and 2b, the lift device 20 is disposed in a cavity of the shell of the spa.

[0022] As shown in FIGS. 3a and 3b, an upper housing (a protective shroud) 202 is provided to house the flat panel TV. The main body of the upper housing 202 is preferably made of polypropylene because of its desirable protective qualities under various harsh conditions, but can also be made of other suitable materials, preferably plastic materials. A lower part of the housing 202 (the part that is hidden below the top edge of the spa, not shown in FIGS. 3a and 3b) is open to allow for air circulation and heat and moisture dissipation. The opening also allows for loading of the TV. The LCD TV is pushed up from below and attached to the lift by means of a lower and an upper mounting brackets (described in more detail later) disposed inside the upper housing. The upper housing 202 is designed to deflect water away from the electronics. A top lid 204 of the upper housing overhangs a trim ring (not shown) to form a weather seal when the TV is lowered. A drip lip 204a is provided in the top lid 204 and molded into its lower perimeter, and serves as a drip director to direct water away from the TV.

[0023] The upper housing 202 has a clear viewing panel or screen 208 which is sealed to prevent water from coming into contact with the TV. The screen preferably has an anti-fog coating on the inside and anti-scratch coating on the outside. It is sealed to the remaining portion of the upper housing with a water resistant double-sided tape around its periphery. Commercially available tapes such as 3M™ No. 9453 tape may be used. The tapeline is concealed with a black silkscreen border of the screen that serves to frame the TV picture and hide the tapeline.

[0024] The upper housing 202 and the TV are supported on a lower case or frame 210 of the lift device. The lower case 210 is preferably made of steel or other suitable materials. In the embodiment shown in FIGS. 1a-1c, the lower case 210 is disposed in the outer housing 21; in the embodiment shown in FIGS. 2a and 2b, the lower case 210 is disposed in the shell of the spa without additional housing. Mounted on the lower case 210 are a linear actuator 212 to drive the up and down movement of the TV and the upper housing 202, and two linear guides (drawer slides) 214 disposed vertically to guide the up and down movement. The linear actuator 212 includes a motor 212a, a cylindrical

shaped body 212b and a shaft 212c disposed within the body. The shaft 212c is driven by the motor 212a and is capable of extending from and retracting into the body 212b. The body 212b of the linear actuator 212 is mounted on the lower case 210 by a center brace 210a and an actuator retaining bracket 210b (see FIG. 5). The linear actuator 212 is also mounted on the floor of the lower case 210. The linear guides 214 are mounted on two vertical side members of the lower case 210.

[0025] FIGS. 4a and 4b illustrate the TV lift device of FIGS. 3a and 3b but without the upper housing 202 and the lower case 210 to show the various attachment structures. As shown in FIGS. 4a and 4b, each linear guide 214 includes a stationary bar 214a vertically mounted on the frame 210 (see FIGS. 3a and 3b), and a sliding member 214b engaged with the stationary bar and freely slideable along it. The TV 30 is attached to the sliding members 214b by a lower mounting bracket 216. The structure of the lower bracket 216 is shown in more detail in FIG. 6 (as viewed from the back of the TV). The TV 30 is attached at a lower portion of its back to an upper vertical portion 216a of the lower bracket 216 by a set of rivets or other suitable means. The lower bracket 216 is attached to the sliding members 214b of the linear guides at two lower vertical portions 216b by a set of rivets or other suitable means. The TV 30 and the sliding members 214b are mounted on opposite sides of the lower bracket 216. The lower bracket 216 also has two vertical tabs 216c for mounting the upper housing 202. The upper end of the shaft 212c of the linear actuator 212 is attached to an upper part of the back of the TV 30 by an upper mounting bracket 218. As a result, when the motor of the linear actuator 212 drives the shaft 212c up and down, the TV 30 is raised and lowered as the sliding members 214b slide along the stationary bars 214a of the linear guides 214. The bracket 216, the linear actuator 212 and the linear guides 214 are designed to eliminate wobble of the TV and provide a smooth upward and downward travel. This design also reduces unwanted forward and backward tilting of the TV.

[0026] An advantage of using a linear actuator as opposed to a motor and a gear drive to drive the up and down motion as in some conventional designs is that actuators are sealed to prevent moisture and dust from attacking the electrical components and shorting out the motor inside. If a simple exposed motor (e.g. a 12 volt motor) with a gear drive is used, protective structures would have to be included in the TV lift device to protect the motor from moisture and dust because of the exterior application, making the device more costly and structurally more complex. Actuators are given an IP (Ingress Protection) rating which designates the degree of protection the actuator offers. Preferably, an actuator used for the TV lift application should have an IP rating of at least 54, but devices with lower IP ratings may also be used.

[0027] It will be apparent to those skilled in the art that various modification and variations can be made in the TV lift device of the present invention without departing from the spirit or scope of the invention. In particular, although a linear actuator and linear guides are used in the embodiments, other motor-driven lift structure may be used. Also, while the structures of the linear actuator, the linear guides and the mounting brackets are described in detail, the invention is not limited to these specific structures. Thus, it



is intended that the present invention cover modifications and variations that come within the scope of the appended claims and their equivalents.

What is claimed is:

1. A television lift device comprising:
  - an upper housing having a clear screen for housing a television panel;
  - a lower case;
  - a linear actuator mounted vertically on the lower case, the linear actuator including a motor, a body and a shaft that extends from or retracts into the body, wherein an upper end of the shaft is adapted for attaching to the television panel;
  - one or more linear guides each including a vertical stationary bar mounted on the lower case and a sliding member engaged with and vertically slideable along the stationary bar; and
  - a mounting bracket having a first portion attached to the sliding members of the linear guides and a second portion adapted for attaching to the television panel.
2. The television lift device of claim 1, further comprising an outer housing adapted for attaching to an outside surface of an outdoor or indoor application, wherein the lower case is disposed within the outer housing.
3. The television lift device of claim 1, wherein the upper housing has a plastic body, wherein the clear screen is sealed to the plastic body by a water resistant double-sided tape around its periphery, and wherein a border is formed on the screen to conceal the tape.
4. The television lift device of claim 1, wherein the upper housing has an overhanging top lid with a drip lip at its lower perimeter.

5. The television lift device of claim 1, wherein the mounting bracket further has a third portion attached to the upper housing.

6. A television lift device for a spa, comprising:

- an upper housing having a clear screen for housing a television panel;
  - a lower case adapted to be fitted within a cavity of a shell of the spa;
  - a linear actuator mounted vertically on the lower case, the linear actuator including a motor, a body and a shaft that extends from or retracts into the body, wherein an upper end of the shaft is adapted for attaching to the television panel;
  - one or more linear guides each including a vertical stationary bar mounted on the lower case and a sliding member engaged with and vertically slideable along the stationary bar; and
  - a mounting bracket having a first portion attached to the sliding members of the linear guides and a second portion adapted for attaching to the television panel.
7. A television lift device comprising:

- an outer housing adapted for attaching to an outside surface of an outdoor or indoor application;
- a lower case disposed within the outer housing;
- an upper housing having a clear screen for housing a television panel; and
- a motor-driven lift structure mounted on the lower case and adapted for attaching to the television panel.

\* \* \* \* \*