



- (51) **International Patent Classification:**  
A61B 5/145 (2006.01) A61B 5/1486 (2006.01)
- (21) **International Application Number:**  
PCT/US2021/065137
- (22) **International Filing Date:**  
23 December 2021 (23.12.2021)
- (25) **Filing Language:** English
- (26) **Publication Language:** English
- (30) **Priority Data:**  
63/129,793 23 December 2020 (23.12.2020) US  
63/132,669 31 December 2020 (31.12.2020) US  
63/257,484 19 October 2021 (19.10.2021) US
- (71) **Applicant: ABBOTT DIABETES CARE INC.** [US/US];  
1420 Harbor Bay Parkway, Alameda, CA 94502 (US).
- (72) **Inventors: LIU, Zenghe;** 2815 Sea View Parkway, Alameda, CA 94502 (US). **KREUTZ, Barry S.;** 2215 W Mon-

trose Ave, Unit 1, Chicago, IL 60618 (US). **OJHA, Yagya Raj;** 1321 Webster Street, Apt D311, Alameda, CA 94501 (US). **FELDMAN, Benjamin J.;** 2164 Blake St., Berkeley, CA 94704 (US). **LEARY, Thomas P.;** 30024 N. Suscito Drive, Peoria, AZ 85383 (US). **NGUYEN, Tram;** 776 Sunset Ave., Apt 1, Suisun, CA 94585 (US).

(74) **Agent: HULSEBERG, Daniel J.** et al.; Baker Botts L.L.P., 30 Rockefeller Plaza, New York, NY 10112 (US).

(81) **Designated States** (unless otherwise indicated, for every kind of national protection available): AE, AG, AL, AM, AO, AT, AU, AZ, BA, BB, BG, BH, BN, BR, BW, BY, BZ, CA, CH, CL, CN, CO, CR, CU, CZ, DE, DJ, DK, DM, DO, DZ, EC, EE, EG, ES, FI, GB, GD, GE, GH, GM, GT, HN, HR, HU, ID, IL, IN, IR, IS, IT, JO, JP, KE, KG, KH, KN, KP, KR, KW, KZ, LA, LC, LK, LR, LS, LU, LY, MA, MD, ME, MG, MK, MN, MW, MX, MY, MZ, NA, NG, NI, NO, NZ, OM, PA, PE, PG, PH, PL, PT, QA, RO, RS, RU, RW,

(54) **Title:** CONTINUOUS POTASSIUM SENSORS AND METHODS OF USE THEREOF

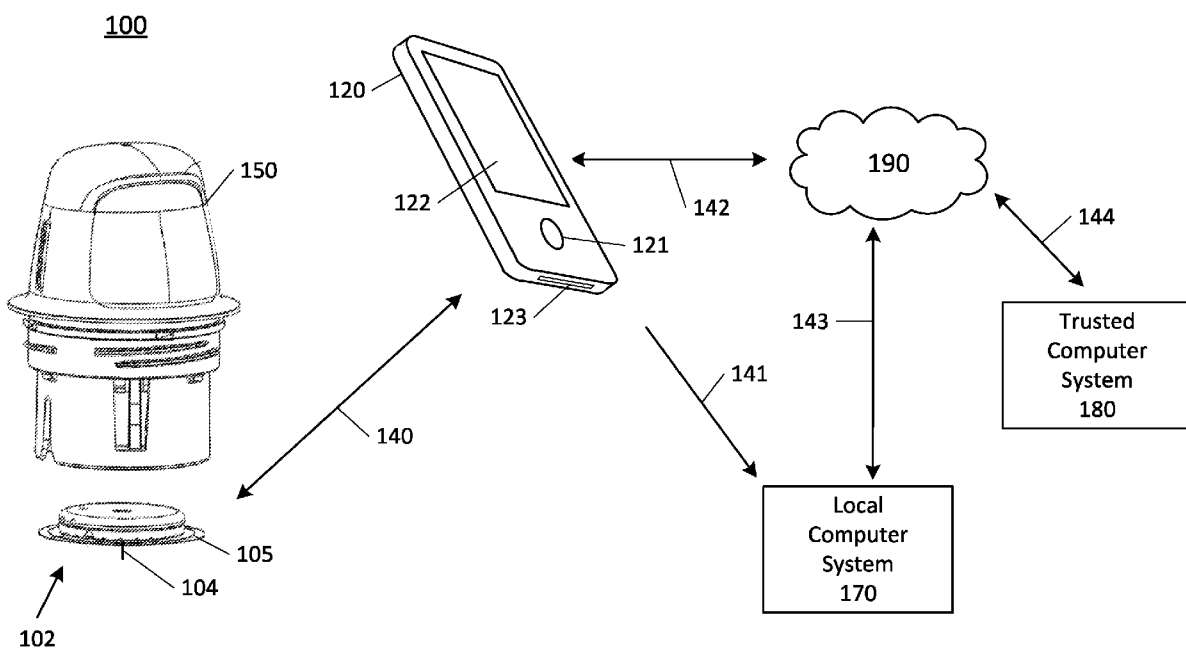

FIG. 1A

(57) **Abstract:** The present disclosure provides an analyte sensor for use in detecting potassium. In certain embodiments, an analyte sensor of the present disclosure includes at least two asparagine-responsive active areas, where each asparagine-responsive active area includes an asparaginase that exhibits a particular potassium dependency. In certain embodiments, an analyte sensor of the present disclosure includes at least two aspartate-responsive active areas, where each aspartate-responsive active area includes an aspartate oxidase that exhibits a particular potassium dependency. The present disclosure further provides methods for monitoring potassium levels, e.g., *in vivo* potassium levels, using the disclosed analyte sensors.



SA, SC, SD, SE, SG, SK, SL, ST, SV, SY, TH, TJ, TM, TN,  
TR, TT, TZ, UA, UG, US, UZ, VC, VN, WS, ZA, ZM, ZW.

- (84) Designated States** (*unless otherwise indicated, for every kind of regional protection available*): ARIPO (BW, GH, GM, KE, LR, LS, MW, MZ, NA, RW, SD, SL, ST, SZ, TZ, UG, ZM, ZW), Eurasian (AM, AZ, BY, KG, KZ, RU, TJ, TM), European (AL, AT, BE, BG, CH, CY, CZ, DE, DK, EE, ES, FI, FR, GB, GR, HR, HU, IE, IS, IT, LT, LU, LV, MC, MK, MT, NL, NO, PL, PT, RO, RS, SE, SI, SK, SM, TR), OAPI (BF, BJ, CF, CG, CI, CM, GA, GN, GQ, GW, KM, ML, MR, NE, SN, TD, TG).

**Published:**

- *with international search report (Art. 21(3))*
- *before the expiration of the time limit for amending the claims and to be republished in the event of receipt of amendments (Rule 48.2(h))*

**CONTINUOUS POTASSIUM SENSORS AND METHODS OF USE THEREOF****CROSS-REFERENCE TO RELATED APPLICATIONS**

5 [0001] This application claims priority to U.S. Provisional Application No. 63/129,793, filed December 23, 2020, U.S. Provisional Application No. 63/132,669, filed December 31, 2020, and U.S. Provisional Application No. 63/257,484, filed October 19, 2021, the contents of each of which are incorporated by reference in their entireties, and to each of which priority is claimed.

10

**FIELD**

[0002] The subject matter described herein relates to analyte sensors for sensing potassium ions and methods of using the same.

**BACKGROUND**

15

[0003] The detection of various analytes within an individual can sometimes be vital for monitoring the condition of their health as deviations from normal analyte levels can be indicative of a physiological condition. For example, monitoring glucose levels can enable people suffering from diabetes to take appropriate corrective action including administration of medicine or consumption of particular food or beverage products to avoid significant physiological harm. Other analytes such as potassium can be desirable to monitor for certain physiological conditions. In certain instances, it can be desirable to monitor more than one analyte to monitor single or multiple physiological conditions, particularly if a person is suffering from comorbid conditions that result in simultaneous dysregulation of two or more analytes in combination with one another.

20

25

[0004] Analyte monitoring in an individual can take place periodically or continuously over a period of time. Periodic analyte monitoring can take place by withdrawing a sample of bodily fluid, such as blood or urine, at set time intervals and analyzing *ex vivo*. Periodic, *ex vivo* analyte monitoring can be sufficient to determine the physiological condition of many individuals. However, *ex vivo* analyte monitoring can be inconvenient or painful in some instances. Moreover, there is no way to recover lost data if an analyte measurement is not obtained at an appropriate time. Continuous analyte monitoring can be conducted using one or more sensors that remain at least partially implanted within a tissue of an individual, such as dermally, subcutaneously or intravenously, so that analyses can be conducted *in vivo*. Implanted sensors can collect analyte data on-demand, at a set schedule,

30

or continuously, depending on an individual's particular health needs and/or previously measured analyte levels. Analyte monitoring with an *in vivo* implanted sensor can be a more desirable approach for individuals having severe analyte dysregulation and/or rapidly fluctuating analyte levels, although it can also be beneficial for other individuals as well.

5 Since implanted analyte sensors often remain within a tissue of an individual for an extended period of time, it can be highly desirable for such analyte sensors to be made from stable materials exhibiting a high degree of biocompatibility.

[0005] Many analytes represent intriguing targets for physiological analyses, provided that a suitable detection chemistry can be identified. To this end, enzyme-based  
10 amperometric sensors configured for assaying glucose continuously *in vivo* have been developed and refined over recent years to aid in monitoring the health of diabetic individuals. Other analytes commonly subject to concurrent dysregulation with glucose in diabetic individuals include, for example, potassium. It can also be desirable to monitor potassium independent of glucose dysregulation as well. For example, potassium levels  
15 can be important to monitor in people suffering various kidney or heart diseases. Implanted analyte sensors configured for detecting potassium *in vivo* are not currently available. Accordingly, there is a need in the art for sensors for detecting potassium *in vivo*.

20

### SUMMARY

[0006] The purpose and advantages of the disclosed subject matter will be set forth in and are apparent from the description that follows, as well as will be learned by practice of the disclosed subject matter. Additional advantages of the disclosed subject matter will be realized and attained by the devices particularly pointed out in the written description and  
25 claims hereof, as well as from the appended drawings.

[0007] To achieve these and other advantages and in accordance with the purpose of the disclosed subject matter, as embodied and broadly described, the disclosed subject matter relates an analyte sensor for monitoring potassium levels *in vivo*.

[0008] In certain embodiments, the analyte sensor includes a sensor tail comprising at least  
30 a first working electrode and a second working electrode. In certain embodiments, the analyte sensor further includes a first analyte-responsive active area disposed upon a surface of the first working electrode, where the first analyte-responsive active area comprises a first aspartate oxidase, and a second analyte-responsive active area disposed upon a surface of the second working electrode, where the second analyte-responsive



active area comprises a second aspartate oxidase. In certain embodiments, the analyte sensor further includes a first mass transport limiting membrane permeable to potassium that overcoats the first analyte-responsive active area and/or the second analyte-responsive area. In certain embodiments, the first aspartate oxidase and the second aspartate oxidase  
5 have different potassium dependencies. For example, but not by way of limitation, the first aspartate oxidase is potassium-independent and the second aspartate oxidase is potassium-dependent.

[0009] In certain embodiments, the first analyte-responsive active area further comprises a first asparaginase and the second analyte-responsive active area further comprises a  
10 second asparaginase. In certain embodiments, the first asparaginase and the second asparaginase have different potassium dependencies. For example, but not by way of limitation, the first asparaginase is potassium-independent and the second asparaginase is potassium-dependent. In certain embodiments, the first aspartate oxidase and the second aspartate oxidase are both potassium-independent. In certain embodiments, the first  
15 analyte-responsive active area comprises a first enzymatic layer comprising the first aspartate oxidase and a second enzymatic layer comprising the first asparaginase disposed upon the first enzymatic layer. In certain embodiments, the second analyte-responsive active area comprises a first enzymatic layer comprising the second aspartate oxidase and a second enzymatic layer comprising the second asparaginase disposed upon the first  
20 enzymatic layer. In certain embodiments, the first analyte-responsive active area comprises a first enzymatic layer comprising the first aspartate oxidase and the first asparaginase. In certain embodiments, the second analyte-responsive active area comprises a first enzymatic layer comprising the aspartate oxidase and the second asparaginase.

[0010] In certain embodiments, the first analyte-responsive active area and/or the second analyte-responsive active area further comprises an electron transfer agent and/or a stabilizing agent. In certain embodiments, the first mass transport limiting membrane comprises a polyvinylpyridine-based polymer, a polyvinylimidazole, a polyacrylate, a polyurethane, a polyether urethane, a silicone or a combination thereof.

[0011] In certain embodiments, the analyte sensor includes a sensor tail comprising at least a first working electrode and a second working electrode. In certain embodiments, a first aspartate-responsive active area is disposed upon a surface of the first working electrode and comprises a potassium-dependent aspartate oxidase. In certain embodiments, a second aspartate-responsive active area is disposed upon a surface of the second working electrode

and comprises a potassium-independent aspartate oxidase. In certain embodiments, a first mass transport limiting membrane permeable to aspartate and potassium overcoats the first aspartate-responsive active area and/or the second aspartate-responsive active area. In certain embodiments, the first and/or second aspartate-responsive active area further  
5 comprises an electron-transfer agent. For example, but not by way of limitation, the first aspartate-responsive active area includes a first electron transfer agent and the second aspartate-responsive active area includes a second electron transfer agent. In certain embodiments, the potassium-dependent aspartate oxidase and/or the first electron transfer agent are covalently bonded to a polymer in the first aspartate-responsive active area. In  
10 certain embodiments, the potassium-independent aspartate oxidase and/or the second electron transfer agent are covalently bonded to a polymer in the second aspartate-responsive active area. In certain embodiments, the first and/or second aspartate-responsive active area further comprises a stabilizer, *e.g.*, a serum albumin. In certain embodiments, the first mass transport limiting membrane comprises a polyvinylpyridine-  
15 based polymer, a polyvinylimidazole, a polyacrylate, a polyurethane, a polyether urethane, a silicone or a combination thereof.

[0012] In certain embodiments, the analyte sensor includes a sensor tail comprising at least a first working electrode and a second working electrode. In certain embodiments, the analyte sensor further includes a first asparagine-responsive active area disposed upon a  
20 surface of the first working electrode, where the first asparagine-responsive active area comprises a first enzyme system comprising a first aspartate oxidase and a first asparaginase, and a second asparagine-responsive active area disposed upon a surface of the second working electrode, where the second asparagine-responsive active area comprises a second enzyme system comprising a second aspartate oxidase and a second  
25 asparaginase. In certain embodiments, the analyte sensor further includes a first mass transport limiting membrane permeable to asparagine that overcoats the first asparagine-responsive active area and/or the second asparagine-responsive area. In certain embodiments, the first aspartate oxidase and the second aspartate oxidase are potassium-independent. In certain embodiments, the first asparaginase and the second asparaginase  
30 have different potassium dependencies. For example, but not by way of limitation, the first asparaginase is potassium-independent and the second asparaginase is potassium-dependent.

[0013] In certain embodiments, the first asparagine-responsive active area and/or the second asparagine-responsive active area further comprises an electron-transfer agent. In

certain embodiments, one or more of the enzymes in the first enzyme system are covalently bonded to a polymer in the first asparagine-responsive active area and/or one or more of the enzymes in the second enzyme system are covalently bonded to a polymer in the second asparagine-responsive area. In certain embodiments, the first mass transport limiting membrane comprises a polyvinylpyridine-based polymer, a polyvinylimidazole, a polyacrylate, a polyurethane, a polyether urethane, a silicone or a combination thereof.

5 [0014] In certain embodiments, the first asparagine-responsive active area includes a first enzyme layer comprising the aspartate oxidase and a second layer comprising the first asparaginase disposed upon the first enzyme layer. In certain embodiments, the first asparagine-responsive active area includes an enzyme layer comprising the aspartate oxidase and the first asparaginase. Alternatively or additionally, the second asparagine-responsive active area includes a first enzyme layer comprising the aspartate oxidase and a second layer comprising the second asparaginase disposed upon the first enzyme layer. In certain embodiments, the second asparagine-responsive active area includes an enzyme layer comprising the aspartate oxidase and the second asparaginase.

10 [0015] In certain embodiments, an analyte sensor of the present disclosure includes a third working electrode and an active area disposed upon a surface of the third working electrode and responsive to a second analyte differing from potassium, wherein the active area comprises at least one enzyme responsive to the second analyte. In certain embodiments, the second analyte is glutamate, glucose, ketones, lactate, oxygen, hemoglobin A1C, albumin, alcohol, alkaline phosphatase, alanine transaminase, aspartate aminotransferase, bilirubin, blood urea nitrogen, calcium, carbon dioxide, chloride, creatinine, hematocrit, lactate, magnesium, oxygen, pH, phosphorus, potassium, sodium, aspartate, asparagine, total protein and/or uric acid. In certain embodiments, a second portion of the mass transport limiting membrane or a second mass transport limiting membrane overcoats the active area on the third working electrode. Alternatively, a second mass transport limiting membrane overcoats the active area on the third working electrode and/or overcoats the active area on the third working electrode and one of more of the asparagine-responsive active areas.

15 [0016] The present disclosure further provides methods for detecting potassium, *e.g.*, potassium ions, in a fluid, *e.g.*, biological fluid. In certain embodiments, any analyte sensor of the present disclosure can be used for detecting potassium, *e.g.*, potassium ions, in a fluid, *e.g.*, biological fluid of a subject. In certain embodiments, the analyte sensor is implanted in a subject at risk of or having a neurological condition or diabetes. In certain

embodiments, the analyte sensor is implanted in a subject for about 15 days.

[0017] In certain embodiments, the method includes providing an analyte sensor, where the analyte sensor includes a sensor tail comprising at least a first working electrode and a second working electrode. In certain embodiments, the analyte sensor further includes a  
5 first analyte-responsive active area disposed upon a surface of the first working electrode, where the first analyte-responsive active area comprises a first aspartate oxidase, and a second analyte-responsive active area disposed upon a surface of the second working electrode, where the second analyte-responsive active area comprises a second aspartate oxidase. In certain embodiments, the analyte sensor further includes a first mass transport  
10 limiting membrane permeable to potassium that overcoats the first analyte-responsive active area and/or the second analyte-responsive area. In certain embodiments, the first aspartate oxidase and the second aspartate oxidase have different potassium dependencies. For example, but not by way of limitation, the first aspartate oxidase is potassium-independent and the second aspartate oxidase is potassium-dependent. In certain  
15 embodiments, the first analyte-responsive active area further comprises a first asparaginase and the second analyte-responsive active area further comprises a second asparaginase. In certain embodiments, the first asparaginase and the second asparaginase have different potassium dependencies. For example, but not by way of limitation, the first asparaginase is potassium-independent and the second asparaginase is potassium-  
20 dependent. In certain embodiments, the method further includes applying a potential to the first working electrode and the second working electrode, obtaining a first signal at or above an oxidation-reduction potential of the first analyte-responsive active area; obtaining a second signal at or above an oxidation-reduction potential of the second analyte-responsive active and correlating the first signal and the second signal to the  
25 concentration of potassium in the fluid.

[0018] In certain embodiments, the method can include providing an analyte sensor that includes a sensor tail comprising at least a first working electrode and a second working electrode; a first aspartate-responsive active area disposed upon a surface of the first working electrode comprising a potassium-dependent aspartate oxidase; a second  
30 aspartate-responsive active area disposed upon a surface of the second working electrode comprising a potassium-independent aspartate oxidase; and a first mass transport limiting membrane permeable to aspartate and potassium that overcoats the first aspartate-responsive active area and/or the second aspartate-responsive active area. In certain embodiments, the method further includes applying a potential to the first working

electrode and the second working electrode, obtaining a first signal at or above an oxidation-reduction potential of the first aspartate-responsive active area; obtaining a second signal at or above an oxidation-reduction potential of the second aspartate-responsive active and correlating the first signal and the second signal to the concentration of potassium in the fluid.

5  
[0019] In certain embodiments, the method includes providing an analyte sensor, where the analyte sensor includes a sensor tail comprising at least a first working electrode and a second working electrode. In certain embodiments, the analyte sensor further includes a first asparagine-responsive active area disposed upon a surface of the first working  
10 electrode, where the first asparagine-responsive active area includes a first enzyme system comprising an aspartate oxidase and a first asparaginase, and a second asparagine-responsive active area disposed upon a surface of the second working electrode, where the second asparagine-responsive active area includes a second enzyme system comprising an aspartate oxidase and a second asparaginase. In certain embodiments, the first aspartate  
15 oxidase and the second aspartate oxidase are potassium-independent. In certain embodiments, the first asparaginase and the second asparaginase have different potassium dependencies. For example, but not by way of limitation, the first asparaginase is potassium-independent and the second asparaginase is potassium-dependent. In certain embodiments, the analyte sensor further includes a first mass transport limiting membrane  
20 permeable to asparagine that overcoats the first asparagine-responsive active area and/or the second asparagine-responsive area. In certain embodiments, the method further includes applying a potential to the first working electrode and the second working electrode. In certain embodiments, the method further includes obtaining a first signal at or above an oxidation-reduction potential of the first asparagine-responsive active area. In  
25 certain embodiments, the method further includes obtaining a second signal at or above an oxidation-reduction potential of the second asparagine-responsive active area. In certain embodiments, the method further includes correlating the first signal and the second to the concentration of potassium ions in the fluid.

[0020] In certain embodiments, the first asparagine-responsive active area and the second  
30 asparagine-responsive active area of the analyte sensor for use in the disclosed methods further comprises an electron-transfer agent. In certain embodiments, one or more of the enzymes in the first enzyme system are covalently bonded to a polymer in the first asparagine-responsive active area and/or wherein one or more of the enzymes in the second enzyme system are covalently bonded to a polymer in the second asparagine-

responsive area. In certain embodiments, the first mass transport limiting membrane comprises a polyvinylpyridine-based polymer, a polyvinylimidazole, a polyacrylate, a polyurethane, a polyether urethane, a silicone or a combination thereof.

5 [0021] In certain embodiments, the first asparagine-responsive active area of the analyte sensor for use in the disclosed methods comprises a first enzyme layer comprising the aspartate oxidase and a second layer comprising the first asparaginase disposed upon the first enzyme layer. In certain embodiments, the first asparagine-responsive active area includes an enzyme layer comprising the aspartate oxidase and the first asparaginase. In certain embodiments, the second asparagine-responsive active area of the analyte sensor  
10 for use in the disclosed methods comprises a first enzyme layer comprising the aspartate oxidase and a second layer comprising the second asparaginase disposed upon the first enzyme layer. In certain embodiments, the second asparagine-responsive active area includes an enzyme layer comprising the aspartate oxidase and the second asparaginase.

15

#### **BRIEF DESCRIPTION OF THE DRAWINGS**

[0022] The following figures are included to illustrate certain aspects of the present disclosure and should not be viewed as exclusive embodiments. The subject matter disclosed is capable of considerable modifications, alterations, combinations, and equivalents in form and function, without departing from the scope of this disclosure.

20 [0023] FIG. 1A is a system overview of a sensor applicator, reader device, monitoring system, network and remote system.

[0024] FIG. 1B is a diagram illustrating an operating environment of an example analyte monitoring system for use with the techniques described herein.

[0025] FIG. 2A is a block diagram depicting an example embodiment of a reader device.

25 [0026] FIG. 2B is a block diagram illustrating an example data receiving device for communicating with the sensor according to exemplary embodiments of the disclosed subject matter.

[0027] FIGS. 2C and 2D are block diagrams depicting example embodiments of sensor control devices.

30 [0028] FIG. 2E is a block diagram illustrating an example analyte sensor according to exemplary embodiments of the disclosed subject matter.

[0029] FIG. 3A is a proximal perspective view depicting an example embodiment of a user preparing a tray for an assembly.

[0030] FIG. 3B is a side view depicting an example embodiment of a user preparing an

applicator device for an assembly.

[0031] FIG. 3C is a proximal perspective view depicting an example embodiment of a user inserting an applicator device into a tray during an assembly.

5 [0032] FIG. 3D is a proximal perspective view depicting an example embodiment of a user removing an applicator device from a tray during an assembly.

[0033] FIG. 3E is a proximal perspective view depicting an example embodiment of a patient applying a sensor using an applicator device.

[0034] FIG. 3F is a proximal perspective view depicting an example embodiment of a patient with an applied sensor and a used applicator device.

10 [0035] FIG. 4A is a side view depicting an example embodiment of an applicator device coupled with a cap.

[0036] FIG. 4B is a side perspective view depicting an example embodiment of an applicator device and cap decoupled.

15 [0037] FIG. 4C is a perspective view depicting an example embodiment of a distal end of an applicator device and electronics housing.

[0038] FIG. 4D is a top perspective view of an exemplary applicator device in accordance with the disclosed subject matter.

[0039] FIG. 4E is a bottom perspective view of the applicator device of FIG. 4D.

[0040] FIG. 4F is an exploded view of the applicator device of FIG. 4D.

20 [0041] FIG. 4G is a side cutaway view of the applicator device of FIG. 4D.

[0042] FIG. 5 is a proximal perspective view depicting an example embodiment of a tray with sterilization lid coupled.

[0043] FIG. 6A is a proximal perspective cutaway view depicting an example embodiment of a tray with sensor delivery components.

25 [0044] FIG. 6B is a proximal perspective view depicting sensor delivery components.

[0045] FIGS. 7A and 7B are isometric exploded top and bottom views, respectively, of an exemplary sensor control device.

[0046] FIG. 8A-8C are assembly and cross-sectional views of an on-body device including an integrated connector for the sensor assembly.

30 [0047] FIGS. 9A and 9B are side and cross-sectional side views, respectively, of an example embodiment of the sensor applicator of FIG. 1A with the cap of FIG. 2C coupled thereto.

[0048] FIGS. 10A and 10B are isometric and side views, respectively, of another example sensor control device.

[0049] FIGS. 11A-11C are progressive cross-sectional side views showing assembly of the sensor applicator with the sensor control device of FIGS. 10A-10B.

[0050] FIGS. 12A-12C are progressive cross-sectional side views showing assembly and disassembly of an example embodiment of the sensor applicator with the sensor control  
5 device of FIGS. 10A-10B.

[0051] FIGS. 13A-13F illustrate cross-sectional views depicting an example embodiment of an applicator during a stage of deployment.

[0052] FIG. 14 is a graph depicting an example of an in vitro sensitivity of an analyte sensor.

10 [0053] FIG. 15 is a diagram illustrating example operational states of the sensor according to exemplary embodiments of the disclosed subject matter.

[0054] FIG. 16 is a diagram illustrating an example operational and data flow for over-the-air programming of a sensor according to the disclosed subject matter.

[0055] FIG. 17 is a diagram illustrating an example data flow for secure exchange of data  
15 between two devices according to the disclosed subject matter.

[0056] FIGS. 18A-18C show cross-sectional diagrams of analyte sensors including a single active area.

[0057] FIGS. 19A-19C show cross-sectional diagrams of analyte sensors including two active areas.

20 [0058] FIG. 20 shows a cross-sectional diagram of an analyte sensor including two active areas.

[0059] FIGS. 21A-21C show perspective views of analyte sensors including two active areas upon separate working electrodes.

[0060] FIG. 22 shows a diagram of a particular enzyme system that can be used for  
25 monitoring potassium according to the present disclosure.

[0061] FIG. 23 shows a diagram of two particular enzyme systems that can be used in combination for monitoring potassium according to the present disclosure. The potassium ion-dependent channel 701 includes an enzyme system comprising a potassium-dependent asparaginase and the potassium ion-independent channel 702 includes an enzyme system  
30 comprising a potassium-independent asparaginase.

[0062] FIG. 24 shows a diagram of two particular enzyme systems that can be used in combination for monitoring potassium according to the present disclosure. The first potassium-dependent channel 801 includes an enzyme system comprising a first potassium-dependent asparaginase and the second potassium-dependent channel 802



includes an enzyme system comprising a second potassium-dependent asparaginase, where the first and second potassium-dependent asparaginases exhibit different potassium dependencies.

5 [0063] FIG. 25A provides current response to asparagine at different concentrations of the two (2) channels of FIG. 24 in the absence of potassium ions.

[0064] FIG. 25B shows the current response to asparagine at a fixed concentration of the two (2) channels of FIG. 24 in the presence of potassium ions.

[0065] FIG. 26 shows current response for analyte sensors of the present disclosure in the presence of various concentrations of asparagine and potassium nitrate.

10 [0066] FIG. 27 shows a diagram of a particular enzyme system that can be used for monitoring potassium according to the present disclosure.

[0067] FIG. 28 provides the current response of a sensor comprising the enzyme system of FIG. 27 to 100  $\mu$ M aspartate at different concentrations of potassium.

15 [0068] FIG. 29 shows the current response of a sensor comprising the enzyme system of FIG. 27 in the presence of various concentrations of aspartate and potassium.

[0069] FIG. 30 shows the percentage increase in current response of a sensor comprising the enzyme system of FIG. 27 in the presence of various concentrations of aspartate and potassium.

20

### **DETAILED DESCRIPTION**

[0070] The present disclosure generally describes analyte sensors employing an enzyme, *e.g.*, one or more enzymes for the detection of an analyte. For example, but not by way of limitation, the present disclosure provides analyte sensors employing one or more enzymes for the detection of potassium. In certain embodiments, the present disclosure provides multiple enzymes for detection of an analyte, *e.g.*, potassium. The present disclosure further provides methods of detecting one or more analytes, *e.g.*, potassium, using the disclosed analyte sensors to monitor a physiological condition.

[0071] The present disclosure provides sensor chemistries suitable for monitoring potassium levels over a range of physiologically relevant potassium concentrations. In certain embodiments, the present disclosure provides sensor chemistries utilizing an enzyme to monitor potassium concentrations, *e.g.*, potassium ion concentrations, in a sample. In certain embodiments, the present disclosure provides sensor chemistries utilizing enzyme systems including at least two enzymes that are capable of acting in concert to monitor potassium concentrations, *e.g.*, potassium ion concentrations, in a

sample. In certain embodiments, two enzyme systems can be used to facilitate indirect measurement of a single analyte such as potassium. As used herein, the term “in concert” refers to a coupled enzymatic reaction, in which a product of a first enzymatic reaction becomes a substrate for a second enzymatic reaction, and the second enzymatic reaction serves as the basis for measuring the concentration of the substrate (*e.g.*, analyte) reacted during the first enzymatic reaction. In certain embodiments, the product and/or substrate of a reaction can be the reduced and/or oxidized form of a cofactor or coenzyme of an enzyme of the enzyme system, *e.g.*, FAD or NAD. Although defined in terms of two coupled enzymatic reactions, it is to be appreciated that more than two enzymatic reactions can be coupled as well in some instances. For example, a product of a first enzymatic reaction can become a substrate of a second enzymatic reaction, and a product of the second enzymatic reaction can become a substrate for a third enzymatic reaction, with the third enzymatic reaction serving as the basis for measuring the concentration of the substrate (*e.g.*, analyte) reacted during the first enzymatic reaction. Discussion of suitable enzyme systems for detecting, *e.g.*, indirectly detecting, potassium according to the disclosure herein follows below.

[0072] For clarity, but not by way of limitation, the detailed description of the presently disclosed subject matter is divided into the following subsections:

- I. Definitions; and
- 20 II. Analyte Sensors;
  1. General Structure of Analyte Sensor Systems;
  2. Enzymes;
  3. Redox Mediators;
  4. Polymeric Backbone;
  - 25 5. Mass Transport Limiting Membrane;
  6. Interference Domain; and
  7. Manufacturing;
- III. Methods of Use; and
- IV. Exemplary Embodiments.

30

## **I. DEFINITIONS**

[0073] The terms used in this specification generally have their ordinary meanings in the art, within the context of this disclosure and in the specific context where each term is used. Certain terms are discussed below, or elsewhere in the specification, to provide

additional guidance to the practitioner in describing the compositions and methods of the present disclosure and how to make and use them.

5 [0074] As used herein, the use of the word “a” or “an” when used in conjunction with the term “comprising” in the claims and/or the specification can mean “one,” but it is also consistent with the meaning of “one or more,” “at least one,” and “one or more than one.”

[0075] The terms “comprise(s),” “include(s),” “having,” “has,” “can,” “contain(s),” and variants thereof, as used herein, are intended to be open-ended transitional phrases, terms or words that do not preclude additional acts or structures. The present disclosure also contemplates other embodiments “comprising,” “consisting of” and “consisting essentially of,” the embodiments or elements presented herein, whether explicitly set forth or not.

10 [0076] The term “about” or “approximately” means within an acceptable error range for the particular value as determined by one of ordinary skill in the art, which depends in part on how the value is measured or determined, *i.e.*, the limitations of the measurement system. For example, “about” can mean within 3 or more than 3 standard deviations, per the practice in the art. Alternatively, “about” can mean a range of up to 20%, preferably up to 10%, more preferably up to 5%, and more preferably still up to 1% of a given value. Alternatively, particularly with respect to biological systems or processes, the term can mean within an order of magnitude, preferably within 5-fold, and more preferably within 2-fold, of a value.

20 [0077] As used herein, “analyte sensor” or “sensor” can refer to any device capable of receiving sensor information from a user, including for purpose of illustration but not limited to, body temperature sensors, blood pressure sensors, pulse or heart-rate sensors, glucose level sensors, analyte sensors, physical activity sensors, body movement sensors, or any other sensors for collecting physical or biological information. Analytes measured by the analyte sensors can include, by way of example and not limitation, glutamate, 25 glucose, ketones, lactate, oxygen, hemoglobin A1C, albumin, alcohol, alkaline phosphatase, alanine transaminase, aspartate aminotransferase, bilirubin, blood urea nitrogen, calcium, carbon dioxide, chloride, creatinine, hematocrit, lactate, magnesium, oxygen, pH, phosphorus, potassium, asparagine, aspartate, sodium, total protein, uric acid, 30 etc.

[0078] The term “biological fluid,” as used herein, refers to any bodily fluid or bodily fluid derivative in which the analyte can be measured. Non-limiting examples of a biological fluid include dermal fluid, interstitial fluid, plasma, blood, lymph, synovial fluid,

cerebrospinal fluid, saliva, bronchoalveolar lavage, amniotic fluid, sweat, tears, or the like. In certain embodiments, the biological fluid is dermal fluid or interstitial fluid.

[0079] The term “electrolysis,” as used herein, refers to electrooxidation or electroreduction of a compound either directly at an electrode or via one or more electron transfer agents (*e.g.*, redox mediators or enzymes).

[0080] As used herein, the term “homogenous membrane” refers to a membrane including a single type of membrane polymer.

[0081] As used herein, the term “multi-component membrane” refers to a membrane including two or more types of membrane polymers.

10 [0082] As used herein, the term “potassium-independent aspartate oxidase” refers to an aspartate oxidase that does not exhibit any change in catalytic activity in the presence of potassium, *e.g.*, potassium ions ( $K^+$ ).

[0083] As used herein, the term “potassium-dependent aspartate oxidase” refers to an aspartate oxidase that exhibits increased or decreased catalytic activity in the presence of potassium, *e.g.*, potassium ions ( $K^+$ ). In certain embodiments, potassium-dependent aspartate oxidases include aspartate oxidases that require different concentrations of potassium, *e.g.*, potassium ions ( $K^+$ ), for maximum catalytic activity.

15 [0084] As used herein, the term “potassium-independent asparaginase” refers to an asparaginase that does not exhibit any change in catalytic activity in the presence of potassium, *e.g.*, potassium ions ( $K^+$ ).

[0085] As used herein, the term “potassium-dependent asparaginase” refers to an asparaginase that exhibits increased or decreased catalytic activity in the presence of potassium, *e.g.*, potassium ions ( $K^+$ ). In certain embodiments, potassium-dependent asparaginases include asparaginases that require different concentrations of potassium, *e.g.*, potassium ions ( $K^+$ ), for maximum catalytic activity.

20 [0086] As used herein, the term “polyvinylpyridine-based polymer” refers to a polymer or copolymer that comprises polyvinylpyridine (*e.g.*, poly(2-vinylpyridine) or poly(4-vinylpyridine)) or a derivative thereof.

[0087] As used herein, the term “redox mediator” refers to an electron transfer agent for carrying electrons between an analyte or an analyte-reduced or analyte oxidized enzyme and an electrode, either directly, or via one or more additional electron transfer agents. In certain embodiments, redox mediators that include a polymeric backbone can also be referred to as “redox polymers.”

[0088] The term “reference electrode” as used herein, can refer to either reference electrodes or electrodes that function as both, a reference and a counter electrode. Similarly, the term “counter electrode,” as used herein, can refer to both, a counter electrode and a counter electrode that also functions as a reference electrode.

5 [0089] As used herein, the term “single-component membrane” refers to a membrane including one type of membrane polymer.

## II. ANALYTE SENSORS

### 1. *General Structure of Analyte Sensor Systems*

10 [0090] Before the present subject matter is described in detail, it is to be understood that this disclosure is not limited to the particular embodiments described, as such may, of course, vary. It is also to be understood that the terminology used herein is for the purpose of describing particular embodiments only, and is not intended to be limiting, since the scope of the present disclosure will be limited only by the appended claims.

15 [0091] The publications discussed herein are provided solely for their disclosure prior to the filing date of the present application. Nothing herein is to be construed as an admission that the present disclosure is not entitled to antedate such publication by virtue of prior disclosure. Further, the dates of publication provided may be different from the actual publication dates which may need to be independently confirmed.

20 [0092] Generally, embodiments of the present disclosure include systems, devices and methods for the use of analyte sensor insertion applicators for use with *in vivo* analyte monitoring systems. An applicator can be provided to the user in a sterile package with an electronics housing of the sensor control device contained therein. According to some embodiments, a structure separate from the applicator, such as a container, can also be  
25 provided to the user as a sterile package with a sensor module and a sharp module contained therein. The user can couple the sensor module to the electronics housing, and can couple the sharp to the applicator with an assembly process that involves the insertion of the applicator into the container in a specified manner. In other embodiments, the applicator, sensor control device, sensor module, and sharp module can be provided in a  
30 single package. The applicator can be used to position the sensor control device on a human body with a sensor in contact with the wearer’s bodily fluid. The embodiments provided herein are improvements to reduce the likelihood that a sensor is improperly inserted or damaged, or elicits an adverse physiological response. Other improvements

and advantages are provided as well. The various configurations of these devices are described in detail by way of the embodiments which are only examples.

[0093] Furthermore, many embodiments include *in vivo* analyte sensors structurally configured so that at least a portion of the sensor is, or can be, positioned in the body of a user to obtain information about at least one analyte of the body. It should be noted, however, that the embodiments disclosed herein can be used with *in vivo* analyte monitoring systems that incorporate *in vitro* capability, as well as purely *in vitro* or *ex vivo* analyte monitoring systems, including systems that are entirely non-invasive.

[0094] Furthermore, for each and every embodiment of a method disclosed herein, systems and devices capable of performing each of those embodiments are covered within the scope of the present disclosure. For example, embodiments of sensor control devices are disclosed and these devices can have one or more sensors, analyte monitoring circuits (e.g., an analog circuit), memories (e.g., for storing instructions), power sources, communication circuits, transmitters, receivers, processors and/or controllers (e.g., for executing instructions) that can perform any and all method steps or facilitate the execution of any and all method steps. These sensor control device embodiments can be used and can be capable of use to implement those steps performed by a sensor control device from any and all of the methods described herein.

[0095] Furthermore, the systems and methods presented herein can be used for operations of a sensor used in an analyte monitoring system, such as but not limited to wellness, fitness, dietary, research, information or any purposes involving analyte sensing over time. As used herein, "analyte sensor" or "sensor" can refer to any device capable of receiving sensor information from a user, including for purpose of illustration but not limited to, body temperature sensors, blood pressure sensors, pulse or heart-rate sensors, glucose level sensors, analyte sensors, physical activity sensors, body movement sensors, or any other sensors for collecting physical or biological information. In certain embodiments, an analyte sensor of the present disclosure can further measure analytes including, but not limited to, glucose, ketones, lactate, oxygen, hemoglobin A1C, albumin, alcohol, alkaline phosphatase, alanine transaminase, aspartate aminotransferase, bilirubin, blood urea nitrogen, calcium, carbon dioxide, chloride, creatinine, hematocrit, lactate, magnesium, oxygen, pH, phosphorus, potassium, sodium, aspartate, asparagine, total protein, uric acid, etc.

[0096] As mentioned, a number of embodiments of systems, devices, and methods are described herein that provide for the improved assembly and use of dermal sensor insertion

devices for use with *in vivo* analyte monitoring systems. In particular, several embodiments of the present disclosure are designed to improve the method of sensor insertion with respect to *in vivo* analyte monitoring systems and, in particular, to prevent the premature retraction of an insertion sharp during a sensor insertion process. Some  
5 embodiments, for example, include a dermal sensor insertion mechanism with an increased firing velocity and a delayed sharp retraction. In other embodiments, the sharp retraction mechanism can be motion-actuated such that the sharp is not retracted until the user pulls the applicator away from the skin. Consequently, these embodiments can reduce the likelihood of prematurely withdrawing an insertion sharp during a sensor insertion  
10 process; decrease the likelihood of improper sensor insertion; and decrease the likelihood of damaging a sensor during the sensor insertion process, to name a few advantages. Several embodiments of the present disclosure also provide for improved insertion sharp modules to account for the small scale of dermal sensors and the relatively shallow insertion path present in a subject's dermal layer. In addition, several embodiments of the  
15 present disclosure are designed to prevent undesirable axial and/or rotational movement of applicator components during sensor insertion. Accordingly, these embodiments can reduce the likelihood of instability of a positioned dermal sensor, irritation at the insertion site, damage to surrounding tissue, and breakage of capillary blood vessels resulting in fouling of the dermal fluid with blood, to name a few advantages. In addition, to mitigate  
20 inaccurate sensor readings which can be caused by trauma at the insertion site, several embodiments of the present disclosure can reduce the end-depth penetration of the needle relative to the sensor tip during insertion.

[0097] Before describing these aspects of the embodiments in detail, however, it is first desirable to describe examples of devices that can be present within, for example, an *in vivo* analyte monitoring system, as well as examples of their operation, all of which can  
25 be used with the embodiments described herein.

[0098] There are various types of *in vivo* analyte monitoring systems. "Continuous Analyte Monitoring" systems (or "Continuous Glucose Monitoring" systems), for example, can transmit data from a sensor control device to a reader device continuously  
30 without prompting, *e.g.*, automatically according to a schedule. "Flash Analyte Monitoring" systems (or "Flash Glucose Monitoring" systems or simply "Flash" systems), as another example, can transfer data from a sensor control device in response to a scan or request for data by a reader device, such as with a Near Field Communication (NFC) or

Radio Frequency Identification (RFID) protocol. *In vivo* analyte monitoring systems can also operate without the need for finger stick calibration.

5 [0099] *In vivo* analyte monitoring systems can be differentiated from “*in vitro*” systems that contact a biological sample outside of the body (or “*ex vivo*”) and that typically include a meter device that has a port for receiving an analyte test strip carrying bodily fluid of the user, which can be analyzed to determine the user’s blood analyte level.

10 [0100] *In vivo* monitoring systems can include a sensor that, while positioned *in vivo*, makes contact with the bodily fluid of the user and senses the analyte levels contained therein. The sensor can be part of the sensor control device that resides on the body of the user and contains the electronics and power supply that enable and control the analyte sensing. The sensor control device, and variations thereof, can also be referred to as a “sensor control unit,” an “on-body electronics” device or unit, an “on-body” device or unit, or a “sensor data communication” device or unit, to name a few.

15 [0101] *In vivo* monitoring systems can also include a device that receives sensed analyte data from the sensor control device and processes and/or displays that sensed analyte data, in any number of forms, to the user. This device, and variations thereof, can be referred to as a “handheld reader device,” “reader device” (or simply a “reader”), “handheld electronics” (or simply a “handheld”), a “portable data processing” device or unit, a “data receiver,” a “receiver” device or unit (or simply a “receiver”), or a “remote” device or unit, to name a few. Other devices such as personal computers have also been utilized with or incorporated into *in vivo* and *in vitro* monitoring systems.

25 [0102] Sensor 104 is adapted to be at least partially inserted into a tissue of interest, such as within the dermal or subcutaneous layer of the skin. Sensor 104 can include a sensor tail of sufficient length for insertion to a desired depth in a given tissue. The sensor tail can include at least one working electrode. In certain configurations, the sensor tail can include at least one active area for detecting an analyte disposed upon the working electrode. A counter electrode can be present in combination with the at least one working electrode. Particular electrode configurations upon the sensor tail are described in more detail below.

30 [0103] The active area can be configured for monitoring a particular analyte, *e.g.*, potassium, *e.g.*, potassium ions. In certain embodiments, the active area can be configured for indirectly monitoring potassium levels in a sample by detecting asparagine. For example, but not by way of limitation, the active area can be configured for indirect measurement of potassium, *e.g.*, potassium ions, by detecting asparagine using enzyme



systems that include potassium-independent and/or potassium-dependent asparaginases. In certain embodiments, the active area can be configured for indirectly monitoring potassium levels in a sample by detecting aspartate. For example, but not by way of limitation, the active area can be configured for indirect measurement of potassium, *e.g.*, potassium ions, by detecting aspartate using enzyme systems that include potassium-independent and/or potassium-dependent aspartate oxidases.

5 [0104] In certain embodiments, the active area can be configured for detecting two or more analytes. In certain embodiments, the active area can be configured for detecting a second analyte. In certain embodiments, the sensor tail can include at least two active areas, where one active area is configured to detect potassium and a second active area is configured to detect a second analyte. Non-limiting examples of second analytes can be glucose, ketones, lactate, oxygen, hemoglobin A1C, albumin, alcohol, alkaline phosphatase, alanine transaminase, aspartate aminotransferase, bilirubin, blood urea nitrogen, calcium, carbon dioxide, chloride, creatinine, hematocrit, lactate, magnesium, oxygen, pH, phosphorus, potassium, sodium, aspartate, asparagine, total protein, uric acid, etc.

10 [0105] In certain embodiments of the present disclosure, one or more analytes can be monitored in any biological fluid of interest such as dermal fluid, interstitial fluid, plasma, blood, lymph, synovial fluid, cerebrospinal fluid, saliva, bronchoalveolar lavage, amniotic fluid, or the like. In certain particular embodiments, analyte sensors of the present disclosure can be adapted for assaying dermal fluid or interstitial fluid to determine a concentration of one or more analytes *in vivo*. In certain embodiments, the biological fluid is interstitial fluid.

15 [0106] An introducer can be present transiently to promote introduction of sensor 104 into a tissue. In certain illustrative embodiments, the introducer can include a needle or similar sharp. As would be readily recognized by a person skilled in the art, other types of introducers, such as sheaths or blades, can be present in alternative embodiments. More specifically, the needle or other introducer can transiently reside in proximity to sensor 104 prior to tissue insertion and then be withdrawn afterward. While present, the needle or other introducer can facilitate insertion of sensor 104 into a tissue by opening an access pathway for sensor 104 to follow. For example, and not by the way of limitation, the needle can facilitate penetration of the epidermis as an access pathway to the dermis to allow implantation of sensor 104 to take place, according to one or more embodiments. After opening the access pathway, the needle or other introducer can be withdrawn so that it does not represent a sharps hazard. In certain embodiments, suitable needles can be solid

or hollow, beveled or non-beveled, and/or circular or non-circular in cross-section. In more particular embodiments, suitable needles can be comparable in cross-sectional diameter and/or tip design to an acupuncture needle, which can have a cross-sectional diameter of about 250 microns. However, suitable needles can have a larger or smaller cross-sectional diameter if needed for certain particular applications.

5 [0107] In certain embodiments, a tip of the needle (while present) can be angled over the terminus of sensor 104, such that the needle penetrates a tissue first and opens an access pathway for sensor 104. In certain embodiments, sensor 104 can reside within a lumen or groove of the needle, with the needle similarly opening an access pathway for sensor 104.  
10 In either case, the needle is subsequently withdrawn after facilitating sensor insertion.

#### *B. Exemplary Reader Device*

[0108] FIG. 2A is a block diagram depicting an example embodiment of a reader device configured as a smartphone. Here, reader device 120 can include a display 122, input component 121, and a processing core 206 including a communications processor 222  
15 coupled with memory 223 and an applications processor 224 coupled with memory 225. Also included can be separate memory 230, RF transceiver 228 with antenna 229, and power supply 226 with power management module 238. Further included can be a multi-functional transceiver 232 which can communicate over Wi-Fi, NFC, Bluetooth, BTLE, and GPS with an antenna 234. As understood by one of skill in the art, these components  
20 are electrically and communicatively coupled in a manner to make a functional device.

#### *C. Exemplary Data Receiving Device Architecture*

[0109] For purpose of illustration and not limitation, reference is made to the exemplary embodiment of a data receiving device 120 for use with the disclosed subject matter as shown in FIG. 2B. The data receiving device 120, and the related multi-purpose data  
25 receiving device 130, includes components germane to the discussion of the analyte sensor 110 and its operations and additional components can be included. In particular embodiments, the data receiving device 120 and multi-purpose data receiving device 130 can be or include components provided by a third party and are not necessarily restricted to include devices made by the same manufacturer as the sensor 110.

30 [0110] As illustrated in FIG. 2B, the data receiving device 120 includes an ASIC 4000 including a microcontroller 4010, memory 4020, and storage 4030 and communicatively coupled with a communication module 4040. Power for the components of the data receiving device 120 can be delivered by a power module 4050, which as embodied herein can include a rechargeable battery. The data receiving device 120 can further include a

display 4070 for facilitating review of analyte data received from an analyte sensor 110 or other device (e.g., user device 140 or remote application server 150). The data receiving device 120 can include separate user interface components (e.g., physical keys, light sensors, microphones, etc.).

5 [0111] The communication module 4040 can include a BLE module 4041 and an NFC module 4042. The data receiving device 120 can be configured to wirelessly couple with the analyte sensor 110 and transmit commands to and receive data from the analyte sensor 110. As embodied herein, the data receiving device 120 can be configured to operate, with respect to the analyte sensor 110 as described herein, as an NFC scanner and a BLE end  
10 point via specific modules (e.g., BLE module 4042 or NFC module 4043) of the communication module 4040. For example, the data receiving device 120 can issue commands (e.g., activation commands for a data broadcast mode of the sensor; pairing commands to identify the data receiving device 120) to the analyte sensor 110 using a first module of the communication module 4040 and receive data from and transmit data to the  
15 analyte sensor 110 using a second module of the communication module 4040. The data receiving device 120 can be configured for communication with a user device 140 via a Universal Serial Bus (USB) module 4045 of the communication module 4040.

[0112] As another example, the communication module 4040 can include, for example, a cellular radio module 4044. The cellular radio module 4044 can include one or more radio  
20 transceivers for communicating using broadband cellular networks, including, but not limited to third generation (3G), fourth generation (4G), and fifth generation (5G) networks. Additionally, the communication module 4040 of the data receiving device 120 can include a Wi-Fi radio module 4043 for communication using a wireless local area network according to one or more of the IEEE 802.11 standards (e.g., 802.11a, 802.11b,  
25 802.11g, 802.11n (aka Wi-Fi 4), 802.11ac (aka Wi-Fi 5), 802.11ax (aka Wi-Fi 6)). Using the cellular radio module 4044 or Wi-Fi radio module 4043, the data receiving device 120 can communicate with the remote application server 150 to receive analyte data or provide updates or input received from a user (e.g., through one or more user interfaces). Although not illustrated, the communication module 5040 of the analyte sensor 120 can similarly  
30 include a cellular radio module or Wi-Fi radio module.

[0113] As embodied herein, the on-board storage 4030 of the data receiving device 120 can store analyte data received from the analyte sensor 110. Further, the data receiving device 120, multi-purpose data receiving device 130, or a user device 140 can be configured to communicate with a remote application server 150 via a wide area network.

As embodied herein, the analyte sensor 110 can provide data to the data receiving device 120 or multi-purpose data receiving device 130. The data receiving device 120 can transmit the data to the user computing device 140. The user computing device 140 (or the multi-purpose data receiving device 130) can in turn transmit that data to a remote application server 150 for processing and analysis.

[0114] As embodied herein, the data receiving device 120 can further include sensing hardware 4060 similar to, or expanded from, the sensing hardware 5060 of the analyte sensor 110. In particular embodiments, the data receiving device 120 can be configured to operate in coordination with the analyte sensor 110 and based on analyte data received from the analyte sensor 110. As an example, where the analyte sensor 110 glucose sensor, the data receiving device 120 can be or include an insulin pump or insulin injection pen. In coordination, the compatible device 130 can adjust an insulin dosage for a user based on glucose values received from the analyte sensor.

#### *D. Exemplary Sensor Control Devices*

[0115] FIGS. 2C and 2D are block diagrams depicting example embodiments of sensor control device 102 having analyte sensor 104 and sensor electronics 160 (including analyte monitoring circuitry) that can have the majority of the processing capability for rendering end-result data suitable for display to the user. In FIG. 2C, a single semiconductor chip 161 is depicted that can be a custom application specific integrated circuit (ASIC). Shown within ASIC 161 are certain high-level functional units, including an analog front end (AFE) 162, power management (or control) circuitry 164, processor 166, and communication circuitry 168 (which can be implemented as a transmitter, receiver, transceiver, passive circuit, or otherwise according to the communication protocol). In this embodiment, both AFE 162 and processor 166 are used as analyte monitoring circuitry, but in other embodiments either circuit can perform the analyte monitoring function. Processor 166 can include one or more processors, microprocessors, controllers, and/or microcontrollers, each of which can be a discrete chip or distributed amongst (and a portion of) a number of different chips.

[0116] A memory 163 is also included within ASIC 161 and can be shared by the various functional units present within ASIC 161, or can be distributed amongst two or more of them. Memory 163 can also be a separate chip. Memory 163 can be volatile and/or non-volatile memory. In this embodiment, ASIC 161 is coupled with power source 170, which can be a coin cell battery, or the like. AFE 162 interfaces with *in vivo* analyte sensor 104 and receives measurement data therefrom and outputs the data to processor 166 in digital

form, which in turn processes the data to arrive at the end-result glucose discrete and trend values, etc. This data can then be provided to communication circuitry 168 for sending, by way of antenna 171, to reader device 120 (not shown), for example, where minimal further processing is needed by the resident software application to display the data.

5 [0117] FIG. 2D is similar to FIG. 2C but instead includes two discrete semiconductor chips 162 and 174, which can be packaged together or separately. Here, AFE 162 is resident on ASIC 161. Processor 166 is integrated with power management circuitry 164 and communication circuitry 168 on chip 174. AFE 162 includes memory 163 and chip 174 includes memory 165, which can be isolated or distributed within. In one example  
10 embodiment, AFE 162 is combined with power management circuitry 164 and processor 166 on one chip, while communication circuitry 168 is on a separate chip. In another example embodiment, both AFE 162 and communication circuitry 168 are on one chip, and processor 166 and power management circuitry 164 are on another chip. It should be noted that other chip combinations are possible, including three or more chips, each  
15 bearing responsibility for the separate functions described, or sharing one or more functions for fail-safe redundancy.

[0118] For purpose of illustration and not limitation, reference is made to the exemplary embodiment of an analyte sensor 110 for use with the disclosed subject matter as shown in FIG. 2E. FIG. 2E illustrates a block diagram of an example analyte sensor 110 according  
20 to exemplary embodiments compatible with the security architecture and communication schemes described herein.

[0119] As embodied herein, the analyte sensor 110 can include an Application-Specific Integrated Circuit ("ASIC") 5000 communicatively coupled with a communication module 5040. The ASIC 5000 can include a microcontroller core 5010, on-board memory 5020, and storage memory 5030. The storage memory 5030 can store data used in an authentication and encryption security architecture. The storage memory 5030 can store  
25 programming instructions for the sensor 110. As embodied herein, certain communication chipsets can be embedded in the ASIC 5000 (e.g., an NFC transceiver 5025). The ASIC 5000 can receive power from a power module 5050, such as an on-board battery or from an NFC pulse. The storage memory 5030 of the ASIC 5000 can be programmed to include  
30 information such as an identifier for the sensor 110 for identification and tracking purposes. The storage memory 5030 can also be programmed with configuration or calibration parameters for use by the sensor 110 and its various components. The storage memory 5030 can include rewritable or one-time programming (OTP) memory. The

storage memory 5030 can be updated using techniques described herein to extend the usefulness of the sensor 110.

[0120] As embodied herein, the communication module 5040 of the sensor 100 can be or include one or more modules to support the analyte sensor 110 communicating with other devices of the analyte monitoring system 100. As an example only and not by way of limitation, example communication modules 5040 can include a Bluetooth Low-Energy (“BLE”) module 5041. As used throughout this disclosure, Bluetooth Low Energy (“BLE”) refers to a short-range communication protocol optimized to make pairing of Bluetooth devices simple for end users. The communication module 5040 can transmit and receive data and commands via interaction with similarly-capable communication modules of a data receiving device 120 or user device 140. The communication module 5040 can include additional or alternative chipsets for use with similar short-range communication schemes, such as a personal area network according to IEEE 802.15 protocols, IEEE 802.11 protocols, infrared communications according to the Infrared Data Association standards (IrDA), etc.

[0121] To perform its functionalities, the sensor 100 can further include suitable sensing hardware 5060 appropriate to its function. As embodied herein, the sensing hardware 5060 can include an analyte sensor transcutaneously or subcutaneously positioned in contact with a bodily fluid of a subject. The analyte sensor can generate sensor data containing values corresponding to levels of one or more analytes within the bodily fluid.

#### *E. Exemplary Assembly Processes for Sensor Control Devices*

[0122] The components of sensor control device 102 can be acquired by a user in multiple packages requiring final assembly by the user before delivery to an appropriate user location. FIGS. 3A-3D depict an example embodiment of an assembly process for sensor control device 102 by a user, including preparation of separate components before coupling the components in order to ready the sensor for delivery. FIGS. 3E-3F depict an example embodiment of delivery of sensor control device 102 to an appropriate user location by selecting the appropriate delivery location and applying device 102 to the location.

[0123] FIG. 3A is a proximal perspective view depicting an example embodiment of a user preparing a container 810, configured here as a tray (although other packages can be used), for an assembly process. The user can accomplish this preparation by removing lid 812 from tray 810 to expose platform 808, for instance by peeling a non-adhered portion of lid 812 away from tray 810 such that adhered portions of lid 812 are removed. Removal

of lid 812 can be appropriate in various embodiments so long as platform 808 is adequately exposed within tray 810. Lid 812 can then be placed aside.

[0124] FIG. 3B is a side view depicting an example embodiment of a user preparing an applicator device 150 for assembly. Applicator device 150 can be provided in a sterile package sealed by a cap 708. Preparation of applicator device 150 can include uncoupling housing 702 from cap 708 to expose sheath 704 (FIG. 3C). This can be accomplished by unscrewing (or otherwise uncoupling) cap 708 from housing 702. Cap 708 can then be placed aside.

[0125] FIG. 3C is a proximal perspective view depicting an example embodiment of a user inserting an applicator device 150 into a tray 810 during an assembly. Initially, the user can insert sheath 704 into platform 808 inside tray 810 after aligning housing orienting feature 1302 (or slot or recess) and tray orienting feature 924 (an abutment or detent). Inserting sheath 704 into platform 808 temporarily unlocks sheath 704 relative to housing 702 and also temporarily unlocks platform 808 relative to tray 810. At this stage, removal of applicator device 150 from tray 810 will result in the same state prior to initial insertion of applicator device 150 into tray 810 (i.e., the process can be reversed or aborted at this point and then repeated without consequence).

[0126] Sheath 704 can maintain position within platform 808 with respect to housing 702 while housing 702 is distally advanced, coupling with platform 808 to distally advance platform 808 with respect to tray 810. This step unlocks and collapses platform 808 within tray 810. Sheath 704 can contact and disengage locking features (not shown) within tray 810 that unlock sheath 704 with respect to housing 702 and prevent sheath 704 from moving (relatively) while housing 702 continues to distally advance platform 808. At the end of advancement of housing 702 and platform 808, sheath 704 is permanently unlocked relative to housing 702. A sharp and sensor (not shown) within tray 810 can be coupled with an electronics housing (not shown) within housing 702 at the end of the distal advancement of housing 702. Operation and interaction of the applicator device 150 and tray 810 are further described below.

[0127] FIG. 3D is a proximal perspective view depicting an example embodiment of a user removing an applicator device 150 from a tray 810 during an assembly. A user can remove applicator 150 from tray 810 by proximally advancing housing 702 with respect to tray 810 or other motions having the same end effect of uncoupling applicator 150 and tray 810. The applicator device 150 is removed with sensor control device 102 (not shown) fully assembled (sharp, sensor, electronics) therein and positioned for delivery.

[0128] FIG. 3E is a proximal perspective view depicting an example embodiment of a patient applying sensor control device 102 using applicator device 150 to a target area of skin, for instance, on an abdomen or other appropriate location. Advancing housing 702 distally collapses sheath 704 within housing 702 and applies the sensor to the target location such that an adhesive layer on the bottom side of sensor control device 102 adheres to the skin. The sharp is automatically retracted when housing 702 is fully advanced, while the sensor (not shown) is left in position to measure analyte levels.

[0129] FIG. 3F is a proximal perspective view depicting an example embodiment of a patient with sensor control device 102 in an applied position. The user can then remove applicator 150 from the application site.

[0130] System 100, described with respect to FIGS. 3A-3F and elsewhere herein, can provide a reduced or eliminated chance of accidental breakage, permanent deformation, or incorrect assembly of applicator components compared to prior art systems. Since applicator housing 702 directly engages platform 808 while sheath 704 unlocks, rather than indirect engagement via sheath 704, relative angularity between sheath 704 and housing 702 will not result in breakage or permanent deformation of the arms or other components. The potential for relatively high forces (such as in conventional devices) during assembly will be reduced, which in turn reduces the chance of unsuccessful user assembly.

#### 20 F. Exemplary Sensor Applicator Devices

[0131] FIG. 4A is a side view depicting an example embodiment of an applicator device 150 coupled with screw cap 708. This is an example of how applicator 150 is shipped to and received by a user, prior to assembly by the user with a sensor. FIG. 4B is a side perspective view depicting applicator 150 and cap 708 after being decoupled. FIG. 4C is a perspective view depicting an example embodiment of a distal end of an applicator device 150 with electronics housing 706 and adhesive patch 105 removed from the position they would have retained within sensor carrier 710 of sheath 704, when cap 708 is in place.

[0132] Referring to FIG. 4D-G for purpose of illustration and not limitation, the applicator device 20150 can be provided to a user as a single integrated assembly. FIGS. 4D and 4E provide perspective top and bottom views, respectively, of the applicator device 20150, FIG. 4F provides an exploded view of the applicator device 20150 and FIG. 4G provides a side cut-away view. The perspective views illustrate how applicator 20150 is shipped to and received by a user. The exploded and cut-away views illustrate the components of the



applicator device 20150. The applicator device 20150 can include a housing 20702, gasket 20701, sheath 20704, sharp carrier 201102, spring 205612, sensor carrier 20710 (also referred to as a “puck carrier”), sharp hub 205014, sensor control device (also referred to as a “puck”) 20102, adhesive patch 20105, desiccant 20502, cap 20708, serial label 20709, and tamper evidence feature 20712. As received by a user, only the housing 20702, cap 20708, tamper evidence feature 20712, and label 20709 are visible. The tamper evidence feature 20712 can be, for example, a sticker coupled to each of the housing 20702 and the cap 20708, and tamper evidence feature 20712 can be damaged, for example, irreparably, by uncoupling housing 20702 and cap 20708, thereby indicating to a user that the housing 20702 and cap 20708 have been previously uncoupled. These features are described in greater detail below.

*G. Exemplary Tray and Sensor Module Assembly*

[0133] FIG. 5 is a proximal perspective view depicting an example embodiment of a tray 810 with sterilization lid 812 removably coupled thereto, which may be representative of how the package is shipped to and received by a user prior to assembly.

[0134] FIG. 6A is a proximal perspective cutaway view depicting sensor delivery components within tray 810. Platform 808 is slidably coupled within tray 810. Desiccant 502 is stationary with respect to tray 810. Sensor module 504 is mounted within tray 810.

[0135] FIG. 6B is a proximal perspective view depicting sensor module 504 in greater detail. Here, retention arm extensions 1834 of platform 808 releasably secure sensor module 504 in position. Module 2200 is coupled with connector 2300, sharp module 2500 and sensor (not shown) such that during assembly they can be removed together as sensor module 504.

*H. Exemplary Applicators and Sensor Control Devices for One Piece Architectures*

[0136] Referring briefly again to FIGS. 1A and 3A-3G, for the two-piece architecture system, the sensor tray 202 and the sensor applicator 102 are provided to the user as separate packages, thus requiring the user to open each package and finally assemble the system. In some applications, the discrete, sealed packages allow the sensor tray 202 and the sensor applicator 102 to be sterilized in separate sterilization processes unique to the contents of each package and otherwise incompatible with the contents of the other. More specifically, the sensor tray 202, which includes the plug assembly 207, including the sensor 110 and the sharp 220, may be sterilized using radiation sterilization, such as electron beam (or “e-beam”) irradiation. Suitable radiation sterilization processes include,

but are not limited to, electron beam (e-beam) irradiation, gamma ray irradiation, X-ray irradiation, or any combination thereof. Radiation sterilization, however, can damage the electrical components arranged within the electronics housing of the sensor control device 102. Consequently, if the sensor applicator 102, which contains the electronics housing of the sensor control device 102, needs to be sterilized, it may be sterilized via another method, such as gaseous chemical sterilization using, for example, ethylene oxide. Gaseous chemical sterilization, however, can damage the enzymes or other chemistry and biologics included on the sensor 110. Because of this sterilization incompatibility, the sensor tray 202 and the sensor applicator 102 are commonly sterilized in separate sterilization processes and subsequently packaged separately, which requires the user to finally assemble the components for use.

[0137] FIGS. 7A and 7B are exploded top and bottom views, respectively, of the sensor control device 3702, according to one or more embodiments. The shell 3706 and the mount 3708 operate as opposing clamshell halves that enclose or otherwise substantially encapsulate the various electronic components of the sensor control device 3702. As illustrated, the sensor control device 3702 may include a printed circuit board assembly (PCBA) 3802 that includes a printed circuit board (PCB) 3804 having a plurality of electronic modules 3806 coupled thereto. Example electronic modules 3806 include, but are not limited to, resistors, transistors, capacitors, inductors, diodes, and switches. Prior sensor control devices commonly stack PCB components on only one side of the PCB. In contrast, the PCB components 3806 in the sensor control device 3702 can be dispersed about the surface area of both sides (i.e., top and bottom surfaces) of the PCB 3804.

[0138] Besides the electronic modules 3806, the PCBA 3802 may also include a data processing unit 3808 mounted to the PCB 3804. The data processing unit 3808 may comprise, for example, an application specific integrated circuit (ASIC) configured to implement one or more functions or routines associated with operation of the sensor control device 3702. More specifically, the data processing unit 3808 may be configured to perform data processing functions, where such functions may include but are not limited to, filtering and encoding of data signals, each of which corresponds to a sampled analyte level of the user. The data processing unit 3808 may also include or otherwise communicate with an antenna for communicating with the reader device 106 (FIG. 1A).

[0139] A battery aperture 3810 may be defined in the PCB 3804 and sized to receive and seat a battery 3812 configured to power the sensor control device 3702. An axial battery contact 3814a and a radial battery contact 3814b may be coupled to the PCB 3804 and

extend into the battery aperture 3810 to facilitate transmission of electrical power from the battery 3812 to the PCB 3804. As their names suggest, the axial battery contact 3814a may be configured to provide an axial contact for the battery 3812, while the radial battery contact 3814b may provide a radial contact for the battery 3812. Locating the battery 3812 within the battery aperture 3810 with the battery contacts 3814a,b helps reduce the height H of the sensor control device 3702, which allows the PCB 3804 to be located centrally and its components to be dispersed on both sides (i.e., top and bottom surfaces). This also helps facilitate the chamfer 3718 provided on the electronics housing 3704.

5 [0140] The sensor 3716 may be centrally located relative to the PCB 3804 and include a tail 3816, a flag 3818, and a neck 3820 that interconnects the tail 3816 and the flag 3818. The tail 3816 may be configured to extend through the central aperture 3720 of the mount 3708 to be transcutaneously received beneath a user's skin. Moreover, the tail 3816 may have an enzyme or other chemistry included thereon to help facilitate analyte monitoring.

10 [0141] The flag 3818 may include a generally planar surface having one or more sensor contacts 3822 (three shown in FIG. 7B) arranged thereon. The sensor contact(s) 3822 may be configured to align with and engage a corresponding one or more circuitry contacts 3824 (three shown in FIG. 7A) provided on the PCB 3804. In some embodiments, the sensor contact(s) 3822 may comprise a carbon impregnated polymer printed or otherwise digitally applied to the flag 3818. Prior sensor control devices typically include a connector made of silicone rubber that encapsulates one or more compliant carbon impregnated polymer modules that serve as electrical conductive contacts between the sensor and the PCB. In contrast, the presently disclosed sensor contact(s) 3822 provide a direct connection between the sensor 3716 and the PCB 3804 connection, which eliminates the need for the prior art connector and advantageously reduces the height H. Moreover, eliminating the compliant carbon impregnated polymer modules eliminates a significant circuit resistance and therefor improves circuit conductivity.

15 [0142] The sensor control device 3702 may further include a compliant member 3826, which may be arranged to interpose the flag 3818 and the inner surface of the shell 3706. More specifically, when the shell 3706 and the mount 3708 are assembled to one another, the compliant member 3826 may be configured to provide a passive biasing load against the flag 3818 that forces the sensor contact(s) 3822 into continuous engagement with the corresponding circuitry contact(s) 3824. In the illustrated embodiment, the compliant member 3826 is an elastomeric O-ring, but could alternatively comprise any other type of

20  
25  
30

biasing device or mechanism, such as a compression spring or the like, without departing from the scope of the disclosure.

5 [0143] The sensor control device 3702 may further include one or more electromagnetic shields, shown as a first shield 3828a and a second shield 3828b. The shell 3706 may provide or otherwise define a first clocking receptacle 3830a (FIG. 7B) and a second clocking receptacle 3830b (FIG. 7B), and the mount 3708 may provide or otherwise define a first clocking post 3832a (FIG. 7A) and a second clocking post 3832b (FIG. 7A). Mating the first and second clocking receptacles 3830a,b with the first and second clocking posts 3832a,b, respectively, will properly align the shell 3706 to the mount 3708.

10 [0144] Referring specifically to FIG. 7A, the inner surface of the mount 3708 may provide or otherwise define a plurality of pockets or depressions configured to accommodate various component parts of the sensor control device 3702 when the shell 3706 is mated to the mount 3708. For example, the inner surface of the mount 3708 may define a battery locator 3834 configured to accommodate a portion of the battery 3812 when the sensor control device 3702 is assembled. An adjacent contact pocket 3836 may be configured to accommodate a portion of the axial contact 3814a.

[0145] Moreover, a plurality of module pockets 3838 may be defined in the inner surface of the mount 3708 to accommodate the various electronic modules 3806 arranged on the bottom of the PCB 3804. Furthermore, a shield locator 3840 may be defined in the inner surface of the mount 3708 to accommodate at least a portion of the second shield 3828b when the sensor control device 3702 is assembled. The battery locator 3834, the contact pocket 3836, the module pockets 3838, and the shield locator 3840 all extend a short distance into the inner surface of the mount 3708 and, as a result, the overall height H of the sensor control device 3702 may be reduced as compared to prior sensor control devices.

25 The module pockets 3838 may also help minimize the diameter of the PCB 3804 by allowing PCB components to be arranged on both sides (i.e., top and bottom surfaces).

[0146] Still referring to FIG. 7A, the mount 3708 may further include a plurality of carrier grip features 3842 (two shown) defined about the outer periphery of the mount 3708. The carrier grip features 3842 are axially offset from the bottom 3844 of the mount 3708, where a transfer adhesive (not shown) may be applied during assembly. In contrast to prior sensor control devices, which commonly include conical carrier grip features that intersect with the bottom of the mount, the presently disclosed carrier grip features 3842 are offset from the plane (i.e., the bottom 3844) where the transfer adhesive is applied. This may prove advantageous in helping ensure that the delivery system does not inadvertently stick

30

to the transfer adhesive during assembly. Moreover, the presently disclosed carrier grip features 3842 eliminate the need for a scalloped transfer adhesive, which simplifies the manufacture of the transfer adhesive and eliminates the need to accurately clock the transfer adhesive relative to the mount 3708. This also increases the bond area and, therefore, the bond strength.

[0147] Referring to FIG. 7B, the bottom 3844 of the mount 3708 may provide or otherwise define a plurality of grooves 3846, which may be defined at or near the outer periphery of the mount 3708 and equidistantly spaced from each other. A transfer adhesive (not shown) may be coupled to the bottom 3844 and the grooves 3846 may be configured to help convey (transfer) moisture away from the sensor control device 3702 and toward the periphery of the mount 3708 during use. In some embodiments, the spacing of the grooves 3846 may interpose the module pockets 3838 (FIG. 7A) defined on the opposing side (inner surface) of the mount 3708. As will be appreciated, alternating the position of the grooves 3846 and the module pockets 3838 ensures that the opposing features on either side of the mount 3708 do not extend into each other. This may help maximize usage of the material for the mount 3708 and thereby help maintain a minimal height H of the sensor control device 3702. The module pockets 3838 may also significantly reduce mold sink, and improve the flatness of the bottom 3844 that the transfer adhesive bonds to.

[0148] Still referring to FIG. 7B, the inner surface of the shell 3706 may also provide or otherwise define a plurality of pockets or depressions configured to accommodate various component parts of the sensor control device 3702 when the shell 3706 is mated to the mount 3708. For example, the inner surface of the shell 3706 may define an opposing battery locator 3848 arrangeable opposite the battery locator 3834 (FIG. 7A) of the mount 3708 and configured to accommodate a portion of the battery 3812 when the sensor control device 3702 is assembled. The opposing battery locator 3848 extends a short distance into the inner surface of the shell 3706, which helps reduce the overall height H of the sensor control device 3702.

[0149] A sharp and sensor locator 3852 may also be provided by or otherwise defined on the inner surface of the shell 3706. The sharp and sensor locator 3852 may be configured to receive both the sharp (not shown) and a portion of the sensor 3716. Moreover, the sharp and sensor locator 3852 may be configured to align and/or mate with a corresponding sharp and sensor locator 2054 (FIG. 7A) provided on the inner surface of the mount 3708.

[0150] According to embodiments of the present disclosure, an alternative sensor assembly/electronics assembly connection approach is illustrated in FIGS. 8A to 8C. As

shown, the sensor assembly 14702 includes sensor 14704, connector support 14706, and sharp 14708. Notably, a recess or receptacle 14710 may be defined in the bottom of the mount of the electronics assembly 14712 and provide a location where the sensor assembly 14702 may be received and coupled to the electronics assembly 14712, and thereby fully assemble the sensor control device. The profile of the sensor assembly 14702 may match or be shaped in complementary fashion to the receptacle 14710, which includes an elastomeric sealing member 14714 (including conductive material coupled to the circuit board and aligned with the electrical contacts of the sensor 14704). Thus, when the sensor assembly 14702 is snap fit or otherwise adhered to the electronics assembly 14712 by driving the sensor assembly 14702 into the integrally formed recess 14710 in the electronics assembly 14712, the on-body device 14714 depicted in FIG. 8C is formed. This embodiment provides an integrated connector for the sensor assembly 14702 within the electronics assembly 14712.

[0151] Additional information regarding sensor assemblies is provided in U.S. Publication No. 2013/0150691 and U.S. Publication No. 2021/0204841, each of which is incorporated by reference herein in its entirety.

[0152] According to embodiments of the present disclosure, the sensor control device 102 may be modified to provide a one-piece architecture that may be subjected to sterilization techniques specifically designed for a one-piece architecture sensor control device. A one-piece architecture allows the sensor applicator 150 and the sensor control device 102 to be shipped to the user in a single, sealed package that does not require any final user assembly steps. Rather, the user need only open one package and subsequently deliver the sensor control device 102 to the target monitoring location. The one-piece system architecture described herein may prove advantageous in eliminating component parts, various fabrication process steps, and user assembly steps. As a result, packaging and waste are reduced, and the potential for user error or contamination to the system is mitigated.

[0153] FIGS. 9A and 9B are side and cross-sectional side views, respectively, of an example embodiment of the sensor applicator 102 with the applicator cap 210 coupled thereto. More specifically, FIG. 9A depicts how the sensor applicator 102 might be shipped to and received by a user, and FIG. 9B depicts the sensor control device 4402 arranged within the sensor applicator 102. Accordingly, the fully assembled sensor control device 4402 may already be assembled and installed within the sensor applicator 102 prior to being delivered to the user, thus removing any additional assembly steps that a user would otherwise have to perform.

[0154] The fully assembled sensor control device 4402 may be loaded into the sensor applicator 102, and the applicator cap 210 may subsequently be coupled to the sensor applicator 102. In some embodiments, the applicator cap 210 may be threaded to the housing 208 and include a tamper ring 4702. Upon rotating (*e.g.*, unscrewing) the applicator cap 210 relative to the housing 208, the tamper ring 4702 may shear and thereby free the applicator cap 210 from the sensor applicator 102.

[0155] According to the present disclosure, while loaded in the sensor applicator 102, the sensor control device 4402 may be subjected to gaseous chemical sterilization 4704 configured to sterilize the electronics housing 4404 and any other exposed portions of the sensor control device 4402. To accomplish this, a chemical may be injected into a sterilization chamber 4706 cooperatively defined by the sensor applicator 102 and the interconnected cap 210. In some applications, the chemical may be injected into the sterilization chamber 4706 via one or more vents 4708 defined in the applicator cap 210 at its proximal end 610. Example chemicals that may be used for the gaseous chemical sterilization 4704 include, but are not limited to, ethylene oxide, vaporized hydrogen peroxide, nitrogen oxide (*e.g.*, nitrous oxide, nitrogen dioxide, etc.), and steam.

[0156] Since the distal portions of the sensor 4410 and the sharp 4412 are sealed within the sensor cap 4416, the chemicals used during the gaseous chemical sterilization process do not interact with the enzymes, chemistry, and biologics provided on the tail 4524 and other sensor components, such as membrane coatings that regulate analyte influx.

[0157] Once a desired sterility assurance level has been achieved within the sterilization chamber 4706, the gaseous solution may be removed and the sterilization chamber 4706 may be aerated. Aeration may be achieved by a series of vacuums and subsequently circulating a gas (*e.g.*, nitrogen) or filtered air through the sterilization chamber 4706. Once the sterilization chamber 4706 is properly aerated, the vents 4708 may be occluded with a seal 4712 (shown in dashed lines).

[0158] In some embodiments, the seal 4712 may comprise two or more layers of different materials. The first layer may be made of a synthetic material (*e.g.*, a flash-spun high-density polyethylene fiber), such as Tyvek® available from DuPont®. Tyvek® is highly durable and puncture resistant and allows the permeation of vapors. The Tyvek® layer can be applied before the gaseous chemical sterilization process, and following the gaseous chemical sterilization process, a foil or other vapor and moisture resistant material layer may be sealed (*e.g.*, heat sealed) over the Tyvek® layer to prevent the ingress of contaminants and moisture into the sterilization chamber 4706. In other embodiments, the

seal 4712 may comprise only a single protective layer applied to the applicator cap 210. In such embodiments, the single layer may be gas permeable for the sterilization process, but may also be capable of protection against moisture and other harmful elements once the sterilization process is complete.

5 [0159] With the seal 4712 in place, the applicator cap 210 provides a barrier against outside contamination, and thereby maintains a sterile environment for the assembled sensor control device 4402 until the user removes (unthreads) the applicator cap 210. The applicator cap 210 may also create a dust-free environment during shipping and storage that prevents the adhesive patch 4714 from becoming dirty.

10 [0160] FIGS. 10A and 10B are isometric and side views, respectively, of another example sensor control device 5002, according to one or more embodiments of the present disclosure. The sensor control device 5002 may be similar in some respects to the sensor control device 102 of FIG. 1A and therefore may be best understood with reference thereto. Moreover, the sensor control device 5002 may replace the sensor control device 102 of  
15 FIG. 1A and, therefore, may be used in conjunction with the sensor applicator 102 of FIG. 1A, which may deliver the sensor control device 5002 to a target monitoring location on a user's skin.

[0161] Unlike the sensor control device 102 of FIG. 1A, however, the sensor control device 5002 may comprise a one-piece system architecture not requiring a user to open  
20 multiple packages and finally assemble the sensor control device 5002 prior to application. Rather, upon receipt by the user, the sensor control device 5002 may already be fully assembled and properly positioned within the sensor applicator 150 (FIG. 1A). To use the sensor control device 5002, the user need only open one barrier (*e.g.*, the applicator cap 708 of FIG. 3B) before promptly delivering the sensor control device 5002 to the target  
25 monitoring location for use.

[0162] As illustrated, the sensor control device 5002 includes an electronics housing 5004 that is generally disc-shaped and may have a circular cross-section. In other embodiments, however, the electronics housing 5004 may exhibit other cross-sectional shapes, such as ovoid or polygonal, without departing from the scope of the disclosure. The electronics  
30 housing 5004 may be configured to house or otherwise contain various electrical components used to operate the sensor control device 5002. In at least one embodiment, an adhesive patch (not shown) may be arranged at the bottom of the electronics housing 5004. The adhesive patch may be similar to the adhesive patch 105 of FIG. 1A, and may thus help adhere the sensor control device 5002 to the user's skin for use.



[0163] As illustrated, the sensor control device 5002 includes an electronics housing 5004 that includes a shell 5006 and a mount 5008 that is matable with the shell 5006. The shell 5006 may be secured to the mount 5008 via a variety of ways, such as a snap fit engagement, an interference fit, sonic welding, one or more mechanical fasteners (*e.g.*, screws), a gasket, an adhesive, or any combination thereof. In some cases, the shell 5006 may be secured to the mount 5008 such that a sealed interface is generated therebetween.

[0164] The sensor control device 5002 may further include a sensor 5010 (partially visible) and a sharp 5012 (partially visible), used to help deliver the sensor 5010 transcutaneously under a user's skin during application of the sensor control device 5002. As illustrated, corresponding portions of the sensor 5010 and the sharp 5012 extend distally from the bottom of the electronics housing 5004 (*e.g.*, the mount 5008). The sharp 5012 may include a sharp hub 5014 configured to secure and carry the sharp 5012. As best seen in FIG. 10B, the sharp hub 5014 may include or otherwise define a mating member 5016. To couple the sharp 5012 to the sensor control device 5002, the sharp 5012 may be advanced axially through the electronics housing 5004 until the sharp hub 5014 engages an upper surface of the shell 5006 and the mating member 5016 extends distally from the bottom of the mount 5008. As the sharp 5012 penetrates the electronics housing 5004, the exposed portion of the sensor 5010 may be received within a hollow or recessed (arcuate) portion of the sharp 5012. The remaining portion of the sensor 5010 is arranged within the interior of the electronics housing 5004.

[0165] The sensor control device 5002 may further include a sensor cap 5018, shown exploded or detached from the electronics housing 5004 in FIGS. 10A-10B. The sensor cap 5018 may be removably coupled to the sensor control device 5002 (*e.g.*, the electronics housing 5004) at or near the bottom of the mount 5008. The sensor cap 5018 may help provide a sealed barrier that surrounds and protects the exposed portions of the sensor 5010 and the sharp 5012 from gaseous chemical sterilization. As illustrated, the sensor cap 5018 may comprise a generally cylindrical body having a first end 5020a and a second end 5020b opposite the first end 5020a. The first end 5020a may be open to provide access into an inner chamber 5022 defined within the body. In contrast, the second end 5020b may be closed and may provide or otherwise define an engagement feature 5024. As described herein, the engagement feature 5024 may help mate the sensor cap 5018 to the cap (*e.g.*, the applicator cap 708 of FIG. 3B) of a sensor applicator (*e.g.*, the sensor applicator 150 of FIGS. 1 and 3A-3G), and may help remove the sensor cap 5018 from the sensor control device 5002 upon removing the cap from the sensor applicator.

[0166] The sensor cap 5018 may be removably coupled to the electronics housing 5004 at or near the bottom of the mount 5008. More specifically, the sensor cap 5018 may be removably coupled to the mating member 5016, which extends distally from the bottom of the mount 5008. In at least one embodiment, for example, the mating member 5016 may define a set of external threads 5026a (FIG. 10B) matable with a set of internal threads 5026b (FIG. 10A) defined by the sensor cap 5018. In some embodiments, the external and internal threads 5026a, b may comprise a flat thread design (e.g., lack of helical curvature), which may prove advantageous in molding the parts. Alternatively, the external and internal threads 5026a,b may comprise a helical threaded engagement. Accordingly, the sensor cap 5018 may be threadably coupled to the sensor control device 5002 at the mating member 5016 of the sharp hub 5014. In other embodiments, the sensor cap 5018 may be removably coupled to the mating member 5016 via other types of engagements including, but not limited to, an interference or friction fit, or a frangible member or substance that may be broken with minimal separation force (e.g., axial or rotational force).

[0167] In some embodiments, the sensor cap 5018 may comprise a monolithic (singular) structure extending between the first and second ends 5020a, b. In other embodiments, however, the sensor cap 5018 may comprise two or more component parts. In the illustrated embodiment, for example, the sensor cap 5018 may include a seal ring 5028 positioned at the first end 5020a and a desiccant cap 5030 arranged at the second end 5020b. The seal ring 5028 may be configured to help seal the inner chamber 5022, as described in more detail below. In at least one embodiment, the seal ring 5028 may comprise an elastomeric O-ring. The desiccant cap 5030 may house or comprise a desiccant to help maintain preferred humidity levels within the inner chamber 5022. The desiccant cap 5030 may also define or otherwise provide the engagement feature 5024 of the sensor cap 5018.

[0168] FIGS. 11A-11C are progressive cross-sectional side views showing assembly of the sensor applicator 102 with the sensor control device 5002, according to one or more embodiments. Once the sensor control device 5002 is fully assembled, it may then be loaded into the sensor applicator 102. With reference to FIG. 11A, the sharp hub 5014 may include or otherwise define a hub snap pawl 5302 configured to help couple the sensor control device 5002 to the sensor applicator 102. More specifically, the sensor control device 5002 may be advanced into the interior of the sensor applicator 102 and the hub snap pawl 5302 may be received by corresponding arms 5304 of a sharp carrier 5306 positioned within the sensor applicator 102.

[0169] In FIG. 11B, the sensor control device 5002 is shown received by the sharp carrier 5306 and, therefore, secured within the sensor applicator 102. Once the sensor control device 5002 is loaded into the sensor applicator 102, the applicator cap 210 may be coupled to the sensor applicator 102. In some embodiments, the applicator cap 210 and the housing 5 208 may have opposing, matable sets of threads 5308 that enable the applicator cap 210 to be screwed onto the housing 208 in a clockwise (or counter-clockwise) direction and thereby secure the applicator cap 210 to the sensor applicator 102.

[0170] As illustrated, the sheath 212 is also positioned within the sensor applicator 102, and the sensor applicator 102 may include a sheath locking mechanism 5310 configured 10 to ensure that the sheath 212 does not prematurely collapse during a shock event. In the illustrated embodiment, the sheath locking mechanism 5310 may comprise a threaded engagement between the applicator cap 210 and the sheath 212. More specifically, one or more internal threads 5312a may be defined or otherwise provided on the inner surface of the applicator cap 210, and one or more external threads 5312b may be defined or 15 otherwise provided on the sheath 212. The internal and external threads 5312a,b may be configured to threadably mate as the applicator cap 210 is threaded to the sensor applicator 102 at the threads 5308. The internal and external threads 5312a,b may have the same thread pitch as the threads 5308 that enable the applicator cap 210 to be screwed onto the housing 208.

[0171] In FIG. 11C, the applicator cap 210 is shown fully threaded (coupled) to the housing 208. As illustrated, the applicator cap 210 may further provide and otherwise 20 define a cap post 5314 centrally located within the interior of the applicator cap 210 and extending proximally from the bottom thereof. The cap post 5314 may be configured to receive at least a portion of the sensor cap 5018 as the applicator cap 210 is screwed onto the housing 208. 25

[0172] With the sensor control device 5002 loaded within the sensor applicator 102 and the applicator cap 210 properly secured, the sensor control device 5002 may then be subjected to a gaseous chemical sterilization configured to sterilize the electronics housing 5004 and any other exposed portions of the sensor control device 5002. Since the distal 30 portions of the sensor 5010 and the sharp 5012 are sealed within the sensor cap 5018, the chemicals used during the gaseous chemical sterilization process are unable to interact with the enzymes, chemistry, and biologics provided on the tail 5104, and other sensor components, such as membrane coatings that regulate analyte influx.

[0173] FIGS. 12A-12C are progressive cross-sectional side views showing assembly and disassembly of an alternative embodiment of the sensor applicator 102 with the sensor control device 5002, according to one or more additional embodiments. A fully assembled sensor control device 5002 may be loaded into the sensor applicator 102 by coupling the hub snap pawl 5302 into the arms 5304 of the sharp carrier 5306 positioned within the sensor applicator 102, as generally described above.

[0174] In the illustrated embodiment, the sheath arms 5604 of the sheath 212 may be configured to interact with a first detent 5702a and a second detent 5702b defined within the interior of the housing 208. The first detent 5702a may alternately be referred to a “locking” detent, and the second detent 5702b may alternately be referred to as a “firing” detent. When the sensor control device 5002 is initially installed in the sensor applicator 102, the sheath arms 5604 may be received within the first detent 5702a. As discussed below, the sheath 212 may be actuated to move the sheath arms 5604 to the second detent 5702b, which places the sensor applicator 102 in firing position.

[0175] In FIG. 12B, the applicator cap 210 is aligned with the housing 208 and advanced toward the housing 208 so that the sheath 212 is received within the applicator cap 210. Instead of rotating the applicator cap 210 relative to the housing 208, the threads of the applicator cap 210 may be snapped onto the corresponding threads of the housing 208 to couple the applicator cap 210 to the housing 208. Axial cuts or slots 5703 (one shown) defined in the applicator cap 210 may allow portions of the applicator cap 210 near its threading to flex outward to be snapped into engagement with the threading of the housing 208. As the applicator cap 210 is snapped to the housing 208, the sensor cap 5018 may correspondingly be snapped into the cap post 5314.

[0176] Similar to the embodiment of FIGS. 11A-11C, the sensor applicator 102 may include a sheath locking mechanism configured to ensure that the sheath 212 does not prematurely collapse during a shock event. In the illustrated embodiment, the sheath locking mechanism includes one or more ribs 5704 (one shown) defined near the base of the sheath 212 and configured to interact with one or more ribs 5706 (two shown) and a shoulder 5708 defined near the base of the applicator cap 210. The ribs 5704 may be configured to inter-lock between the ribs 5706 and the shoulder 5708 while attaching the applicator cap 210 to the housing 208. More specifically, once the applicator cap 210 is snapped onto the housing 208, the applicator cap 210 may be rotated (*e.g.*, clockwise), which locates the ribs 5704 of the sheath 212 between the ribs 5706 and the shoulder 5708 of the applicator cap 210 and thereby “locks” the applicator cap 210 in place until the user

reverse rotates the applicator cap 210 to remove the applicator cap 210 for use. Engagement of the ribs 5704 between the ribs 5706 and the shoulder 5708 of the applicator cap 210 may also prevent the sheath 212 from collapsing prematurely.

5 [0177] In FIG. 12C, the applicator cap 210 is removed from the housing 208. As with the embodiment of FIGS. 12A-12C, the applicator cap 210 can be removed by reverse rotating the applicator cap 210, which correspondingly rotates the cap post 5314 in the same direction and causes sensor cap 5018 to unthread from the mating member 5016, as generally described above. Moreover, detaching the sensor cap 5018 from the sensor control device 5002 exposes the distal portions of the sensor 5010 and the sharp 5012.

10 [0178] As the applicator cap 210 is unscrewed from the housing 208, the ribs 5704 defined on the sheath 212 may slidingly engage the tops of the ribs 5706 defined on the applicator cap 210. The tops of the ribs 5706 may provide corresponding ramped surfaces that result in an upward displacement of the sheath 212 as the applicator cap 210 is rotated, and moving the sheath 212 upward causes the sheath arms 5604 to flex out of engagement with the first detent 5702a to be received within the second detent 5702b. As the sheath 212 moves to the second detent 5702b, the radial shoulder 5614 moves out of radial engagement with the carrier arm(s) 5608, which allows the passive spring force of the spring 5612 to push upward on the sharp carrier 5306 and force the carrier arm(s) 5608 out of engagement with the groove(s) 5610. As the sharp carrier 5306 moves upward

15 within the housing 208, the mating member 5016 may correspondingly retract until it becomes flush, substantially flush, or sub-flush with the bottom of the sensor control device 5002. At this point, the sensor applicator 102 is in firing position. Accordingly, in this embodiment, removing the applicator cap 210 correspondingly causes the mating member 5016 to retract.

25 *I. Exemplary Firing Mechanism of One-Piece and Two-Piece Applicators*

[0179] FIGS. 13A-13F illustrate example details of embodiments of the internal device mechanics of “firing” the applicator 216 to apply sensor control device 222 to a user and including retracting sharp 1030 safely back into used applicator 216. All together, these drawings represent an example sequence of driving sharp 1030 (supporting a sensor coupled to sensor control device 222) into the skin of a user, withdrawing the sharp while leaving the sensor behind in operative contact with interstitial fluid of the user, and adhering the sensor control device to the skin of the user with an adhesive. Modification of such activity for use with the alternative applicator assembly embodiments and

30

components can be appreciated in reference to the same by those with skill in the art. Moreover, applicator 216 may be a sensor applicator having one-piece architecture or a two-piece architecture as disclosed herein.

[0180] Turning now to FIG. 13A, a sensor 1102 is supported within sharp 1030, just  
5 above the skin 1104 of the user. Rails 1106 (optionally three of them) of an upper guide section 1108 may be provided to control applicator 216 motion relative to sheath 318. The sheath 318 is held by detent features 1110 within the applicator 216 such that appropriate downward force along the longitudinal axis of the applicator 216 will cause the resistance provided by the detent features 1110 to be overcome so that sharp 1030 and sensor control  
10 device 222 can translate along the longitudinal axis into (and onto) skin 1104 of the user. In addition, catch arms 1112 of sensor carrier 1022 engage the sharp retraction assembly 1024 to maintain the sharp 1030 in a position relative to the sensor control device 222.

[0181] In FIG. 13B, user force is applied to overcome or override detent features 1110 and  
15 sheath 318 collapses into housing 314 driving the sensor control device 222 (with associated parts) to translate down as indicated by the arrow L along the longitudinal axis. An inner diameter of the upper guide section 1108 of the sheath 318 constrains the position of carrier arms 1112 through the full stroke of the sensor/sharp insertion process. The retention of the stop surfaces 1114 of carrier arms 1112 against the complimentary  
20 faces 1116 of the sharp retraction assembly 1024 maintains the position of the members with return spring 1118 fully energized. According to embodiments, rather than employing user force to drive the sensor control device 222 to translate down as indicated by the arrow L along the longitudinal axis, housing 314 can include a button (for example, not limitation, a push button) which activates a drive spring (for example, not limitation,  
25 a coil spring) to drive the sensor control device 222.

[0182] In FIG. 13C, sensor 1102 and sharp 1030 have reached full insertion depth. In so  
doing, the carrier arms 1112 clear the upper guide section 1108 inner diameter. Then, the compressed force of the coil return spring 1118 drives angled stop surfaces 1114 radially outward, releasing force to drive the sharp carrier 1102 of the sharp retraction  
30 assembly 1024 to pull the (slotted or otherwise configured) sharp 1030 out of the user and off of the sensor 1102 as indicated by the arrow R in FIG. 13D.

[0183] With the sharp 1030 fully retracted as shown in FIG. 13E, the upper guide section 1108 of the sheath 318 is set with a final locking feature 1120. As shown in FIG. 13F, the spent applicator assembly 216 is removed from the insertion site, leaving behind

the sensor control device 222, and with the sharp 1030 secured safely inside the applicator assembly 216. The spent applicator assembly 216 is now ready for disposal.

5 [0184] Operation of the applicator 216 when applying the sensor control device 222 is designed to provide the user with a sensation that both the insertion and retraction of the sharp 1030 is performed automatically by the internal mechanisms of the applicator 216. In other words, the present invention avoids the user experiencing the sensation that he is manually driving the sharp 1030 into his skin. Thus, once the user applies sufficient force to overcome the resistance from the detent features of the applicator 216, the resulting actions of the applicator 216 are perceived to be an automated response to the applicator being “triggered.” The user does not perceive that he is supplying additional force to drive the sharp 1030 to pierce his skin despite that all the driving force is provided by the user and no additional biasing/driving means are used to insert the sharp 1030. As detailed above in FIG. 13C, the retraction of the sharp 1030 is automated by the coil return spring 1118 of the applicator 216.

15 [0185] With respect to any of the applicator embodiments described herein, as well as any of the components thereof, including but not limited to the sharp, sharp module and sensor module embodiments, those of skill in the art will understand that said embodiments can be dimensioned and configured for use with sensors configured to sense an analyte level in a bodily fluid in the epidermis, dermis, or subcutaneous tissue of a subject. In some embodiments, for example, sharps and distal portions of analyte sensors disclosed herein can both be dimensioned and configured to be positioned at a particular end-depth (*i.e.*, the furthest point of penetration in a tissue or layer of the subject’s body, *e.g.*, in the epidermis, dermis, or subcutaneous tissue). With respect to some applicator embodiments, those of skill in the art will appreciate that certain embodiments of sharps can be dimensioned and configured to be positioned at a different end-depth in the subject’s body relative to the final end-depth of the analyte sensor. In some embodiments, for example, a sharp can be positioned at a first end-depth in the subject’s epidermis prior to retraction, while a distal portion of an analyte sensor can be positioned at a second end-depth in the subject’s dermis. In other embodiments, a sharp can be positioned at a first end-depth in the subject’s dermis prior to retraction, while a distal portion of an analyte sensor can be positioned at a second end-depth in the subject’s subcutaneous tissue. In still other embodiments, a sharp can be positioned at a first end-depth prior to retraction and the analyte sensor can be positioned at a second end-depth, wherein the first end-depth and second end-depths are both in the same layer or tissue of the subject’s body.

[0186] Additionally, with respect to any of the applicator embodiments described herein, those of skill in the art will understand that an analyte sensor, as well as one or more structural components coupled thereto, including but not limited to one or more spring-mechanisms, can be disposed within the applicator in an off-center position relative to one or more axes of the applicator. In some applicator embodiments, for example, an analyte sensor and a spring mechanism can be disposed in a first off-center position relative to an axis of the applicator on a first side of the applicator, and the sensor electronics can be disposed in a second off-center position relative to the axis of the applicator on a second side of the applicator. In other applicator embodiments, the analyte sensor, spring mechanism, and sensor electronics can be disposed in an off-center position relative to an axis of the applicator on the same side. Those of skill in the art will appreciate that other permutations and configurations in which any or all of the analyte sensor, spring mechanism, sensor electronics, and other components of the applicator are disposed in a centered or off-centered position relative to one or more axes of the applicator are possible and fully within the scope of the present disclosure.

[0187] Additional details of suitable devices, systems, methods, components and the operation thereof along with related features are set forth in International Publication No. WO 2018/136898 to Rao et al., International Publication No. WO 2019/236850 to Thomas et al., International Publication No. WO 2019/236859 to Thomas et al., International Publication No. WO 2019/236876 to Thomas et al., and U.S. Patent Publication No. 2020/0196919, filed June 6, 2019, each of which is incorporated by reference in its entirety herein. Further details regarding embodiments of applicators, their components, and variants thereof, are described in U.S. Patent Publication Nos. 2013/0150691, 2016/0331283, and 2018/0235520, all of which are incorporated by reference herein in their entireties and for all purposes. Further details regarding embodiments of sharp modules, sharps, their components, and variants thereof, are described in U.S. Patent Publication No. 2014/0171771, which is incorporated by reference herein in its entirety and for all purposes.

#### *J. Exemplary Methods of Calibrating Analyte Sensors*

[0188] Biochemical sensors can be described by one or more sensing characteristics. A common sensing characteristic is referred to as the biochemical sensor's sensitivity, which is a measure of the sensor's responsiveness to the concentration of the chemical or composition it is designed to detect. For electrochemical sensors, this response can be in the form of an electrical current (amperometric) or electrical charge (coulometric). For



other types of sensors, the response can be in a different form, such as a photonic intensity (e.g., optical light). The sensitivity of a biochemical analyte sensor can vary depending on a number of factors, including whether the sensor is in an *in vitro* state or an *in vivo* state.

[0189] FIG. 14 is a graph depicting the *in vitro* sensitivity of an amperometric analyte sensor. The *in vitro* sensitivity can be obtained by *in vitro* testing the sensor at various analyte concentrations and then performing a regression (e.g., linear or non-linear) or other curve fitting on the resulting data. In this example, the analyte sensor's sensitivity is linear, or substantially linear, and can be modeled according to the equation  $y=mx+b$ , where  $y$  is the sensor's electrical output current,  $x$  is the analyte level (or concentration),  $m$  is the slope of the sensitivity and  $b$  is the intercept of the sensitivity, where the intercept generally corresponds to a background signal (e.g., noise). For sensors with a linear or substantially linear response, the analyte level that corresponds to a given current can be determined from the slope and intercept of the sensitivity. Sensors with a non-linear sensitivity require additional information to determine the analyte level resulting from the sensor's output current, and those of ordinary skill in the art are familiar with manners by which to model non-linear sensitivities. In certain embodiments of *in vivo* sensors, the *in vitro* sensitivity can be the same as the *in vivo* sensitivity, but in other embodiments a transfer (or conversion) function is used to translate the *in vitro* sensitivity into the *in vivo* sensitivity that is applicable to the sensor's intended *in vivo* use.

[0190] Calibration is a technique for improving or maintaining accuracy by adjusting a sensor's measured output to reduce the differences with the sensor's expected output. One or more parameters that describe the sensor's sensing characteristics, like its sensitivity, are established for use in the calibration adjustment.

[0191] Certain *in vivo* analyte monitoring systems require calibration to occur after implantation of the sensor into the user or patient, either by user interaction or by the system itself in an automated fashion. For example, when user interaction is required, the user performs an *in vitro* measurement (e.g., a blood glucose (BG) measurement using a finger stick and an *in vitro* test strip) and enters this into the system, while the analyte sensor is implanted. The system then compares the *in vitro* measurement with the *in vivo* signal and, using the differential, determines an estimate of the sensor's *in vivo* sensitivity. The *in vivo* sensitivity can then be used in an algorithmic process to transform the data collected with the sensor to a value that indicates the user's analyte level. This and other processes that require user action to perform calibration are referred to as "user calibration." Systems can require user calibration due to instability of the sensor's

sensitivity, such that the sensitivity drifts or changes over time. Thus, multiple user calibrations (*e.g.*, according to a periodic (*e.g.*, daily) schedule, variable schedule, or on an as-needed basis) can be required to maintain accuracy. While the embodiments described herein can incorporate a degree of user calibration for a particular implementation, generally this is not preferred as it requires the user to perform a painful or otherwise burdensome BG measurement, and can introduce user error.

5 [0192] Some *in vivo* analyte monitoring systems can regularly adjust the calibration parameters through the use of automated measurements of characteristics of the sensor made by the system itself (*e.g.*, processing circuitry executing software). The repeated adjustment of the sensor's sensitivity based on a variable measured by the system (and not 10 the user) is referred to generally as "system" (or automated) calibration, and can be performed with user calibration, such as an early BG measurement, or without user calibration. Like the case with repeated user calibrations, repeated system calibrations are typically necessitated by drift in the sensor's sensitivity over time. Thus, while the 15 embodiments described herein can be used with a degree of automated system calibration, preferably the sensor's sensitivity is relatively stable over time such that post-implantation calibration is not required.

[0193] Some *in vivo* analyte monitoring systems operate with a sensor that is factory calibrated. Factory calibration refers to the determination or estimation of the one or more 20 calibration parameters prior to distribution to the user or healthcare professional (HCP). The calibration parameter can be determined by the sensor manufacturer (or the manufacturer of the other components of the sensor control device if the two entities are different). Many *in vivo* sensor manufacturing processes fabricate the sensors in groups or batches referred to as production lots, manufacturing stage lots, or simply lots. A single 25 lot can include thousands of sensors.

[0194] Sensors can include a calibration code or parameter which can be derived or determined during one or more sensor manufacturing processes and coded or programmed, as part of the manufacturing process, in the data processing device of the analyte monitoring system or provided on the sensor itself, for example, as a bar code, a laser tag, 30 an RFID tag, or other machine readable information provided on the sensor. User calibration during *in vivo* use of the sensor can be obviated, or the frequency of *in vivo* calibrations during sensor wear can be reduced if the code is provided to a receiver (or other data processing device). In embodiments where the calibration code or parameter is provided on the sensor itself, prior to or at the start of the sensor use, the calibration code

or parameter can be automatically transmitted or provided to the data processing device in the analyte monitoring system.

5 [0195] Some *in vivo* analyte monitoring system operate with a sensor that can be one or more of factory calibrated, system calibrated, and/or user calibrated. For example, the sensor can be provided with a calibration code or parameter which can allow for factory calibration. If the information is provided to a receiver (for example, entered by a user), the sensor can operate as a factory calibrated sensor. If the information is not provided to a receiver, the sensor can operate as a user calibrated sensor and/or a system calibrated sensor.

10 [0196] In a further aspect, programming or executable instructions can be provided or stored in the data processing device of the analyte monitoring system, and/or the receiver/controller unit, to provide a time varying adjustment algorithm to the *in vivo* sensor during use. For example, based on a retrospective statistical analysis of analyte sensors used *in vivo* and the corresponding glucose level feedback, a predetermined or analytical curve or a database can be generated which is time based, and configured to provide additional adjustment to the one or more *in vivo* sensor parameters to compensate for potential sensor drift in stability profile, or other factors.

15 [0197] In accordance with the disclosed subject matter, the analyte monitoring system can be configured to compensate or adjust for the sensor sensitivity based on a sensor drift profile. A time varying parameter  $\beta(t)$  can be defined or determined based on analysis of sensor behavior during *in vivo* use, and a time varying drift profile can be determined. In certain aspects, the compensation or adjustment to the sensor sensitivity can be programmed in the receiver unit, the controller or data processor of the analyte monitoring system such that the compensation or the adjustment or both can be performed automatically and/or iteratively when sensor data is received from the analyte sensor. In accordance with the disclosed subject matter, the adjustment or compensation algorithm can be initiated or executed by the user (rather than self-initiating or executing) such that the adjustment or the compensation to the analyte sensor sensitivity profile is performed or executed upon user initiation or activation of the corresponding function or routine, or upon the user entering the sensor calibration code.

25 [0198] In accordance with the disclosed subject matter, each sensor in the sensor lot (in some instances not including sample sensors used for *in vitro* testing) can be examined non-destructively to determine or measure its characteristics such as membrane thickness at one or more points of the sensor, and other characteristics including physical

characteristics such as the surface area/volume of the active area can be measured or determined. Such measurement or determination can be performed in an automated manner using, for example, optical scanners or other suitable measurement devices or systems, and the determined sensor characteristics for each sensor in the sensor lot is compared to the corresponding mean values based on the sample sensors for possible correction of the calibration parameter or code assigned to each sensor. For example, for a calibration parameter defined as the sensor sensitivity, the sensitivity is approximately inversely proportional to the membrane thickness, such that, for example, a sensor having a measured membrane thickness of approximately 4% greater than the mean membrane thickness for the sampled sensors from the same sensor lot as the sensor, the sensitivity assigned to that sensor in one embodiment is the mean sensitivity determined from the sampled sensors divided by 1.04. Likewise, since the sensitivity is approximately proportional to active area of the sensor, a sensor having measured active area of approximately 3% lower than the mean active area for the sampled sensors from the same sensor lot, the sensitivity assigned to that sensor is the mean sensitivity multiplied by 0.97. The assigned sensitivity can be determined from the mean sensitivity from the sampled sensors, by multiple successive adjustments for each examination or measurement of the sensor. In certain embodiments, examination or measurement of each sensor can additionally include measurement of membrane consistency or texture in addition to the membrane thickness and/or surface area or volume of the active sensing area.

[0199] Additional information regarding sensor calibration is provided in U.S. Publication No. 2010/00230285 and U.S. Publication No. 2019/0274598, each of which is incorporated by reference herein in its entirety.

*K. Exemplary Bluetooth Communication Protocols*

[0200] The storage memory 5030 of the sensor 110 can include the software blocks related to communication protocols of the communication module. For example, the storage memory 5030 can include a BLE services software block with functions to provide interfaces to make the BLE module 5041 available to the computing hardware of the sensor 110. These software functions can include a BLE logical interface and interface parser. BLE services offered by the communication module 5040 can include the generic access profile service, the generic attribute service, generic access service, device information service, data transmission services, and security services. The data transmission service can be a primary service used for transmitting data such as sensor control data, sensor status data, analyte measurement data (historical and current), and event log data. The

sensor status data can include error data, current time active, and software state. The analyte measurement data can include information such as current and historical raw measurement values, current and historical values after processing using an appropriate algorithm or model, projections and trends of measurement levels, comparisons of other values to patient-specific averages, calls to action as determined by the algorithms or models and other similar types of data.

[0201] According to aspects of the disclosed subject matter, and as embodied herein, a sensor 110 can be configured to communicate with multiple devices concurrently by adapting the features of a communication protocol or medium supported by the hardware and radios of the sensor 110. As an example, the BLE module 5041 of the communication module 5040 can be provided with software or firmware to enable multiple concurrent connections between the sensor 110 as a central device and the other devices as peripheral devices, or as a peripheral device where another device is a central device.

[0202] Connections, and ensuing communication sessions, between two devices using a communication protocol such as BLE can be characterized by a similar physical channel operated between the two devices (*e.g.*, a sensor 110 and data receiving device 120). The physical channel can include a single channel or a series of channels, including for example and without limitation using an agreed upon series of channels determined by a common clock and channel- or frequency-hopping sequence. Communication sessions can use a similar amount of the available communication spectrum, and multiple such communication sessions can exist in proximity. In certain embodiment, each collection of devices in a communication session uses a different physical channel or series of channels, to manage interference of devices in the same proximity.

[0203] For purpose of illustration and not limitation, reference is made to an exemplary embodiment of a procedure for a sensor-receiver connection for use with the disclosed subject matter. First, the sensor 110 repeatedly advertises its connection information to its environment in a search for a data receiving device 120. The sensor 110 can repeat advertising on a regular basis until a connection established. The data receiving device 120 detects the advertising packet and scans and filters for the sensor 120 to connect to through the data provided in the advertising packet. Next, data receiving device 120 sends a scan request command and the sensor 110 responds with a scan response packet providing additional details. Then, the data receiving device 120 sends a connection request using the Bluetooth device address associated with the data receiving device 120. The data receiving device 120 can also continuously request to establish a connection to a sensor

110 with a specific Bluetooth device address. Then, the devices establish an initial connection allowing them to begin to exchange data. The devices begin a process to initialize data exchange services and perform a mutual authentication procedure.

[0204] During a first connection between the sensor 110 and data receiving device 120, 5 the data receiving device 120 can initialize a service, characteristic, and attribute discovery procedure. The data receiving device 120 can evaluate these features of the sensor 110 and store them for use during subsequent connections. Next, the devices enable a notification for a customized security service used for mutual authentication of the sensor 110 and data receiving device 120. The mutual authentication procedure can be automated and require 10 no user interaction. Following the successful completion of the mutual authentication procedure, the sensor 110 sends a connection parameter update to request the data receiving device 120 to use connection parameter settings preferred by the sensor 110 and configured to maximum longevity.

[0205] The data receiving device 120 then performs sensor control procedures to backfill 15 historical data, current data, event log, and factory data. As an example, for each type of data, the data receiving device 120 sends a request to initiate a backfill process. The request can specify a range of records defined based on, for example, the measurement value, timestamp, or similar, as appropriate. The sensor 110 responds with requested data until all previously unsent data in the memory of the sensor 110 is delivered to the data receiving 20 device 120. The sensor 110 can respond to a backfill request from the data receiving device 120 that all data has already been sent. Once backfill is completed, the data receiving device 120 can notify sensor 110 that it is ready to receive regular measurement readings. The sensor 110 can send readings across multiple notifications result on a repeating basis. As embodied herein, the multiple notifications can be redundant notifications to ensure 25 that data is transmitted correctly. Alternatively, multiple notifications can make up a single payload.

[0206] For purpose of illustration and not limitation, reference is made to an exemplary embodiment of a procedure to send a shutdown command to the sensor 110. The shutdown operation is executed if the sensor 110 is in, for example, an error state, insertion failed 30 state, or sensor expired state. If the sensor 110 is not in those states, the sensor 110 can log the command and execute the shutdown when sensor 110 transitions into the error state or sensor expired state. The data receiving device 120 sends a properly formatted shutdown command to the sensor 110. If the sensor 110 is actively processing another command, the sensor 110 will respond with a standard error response indicating that the sensor 110 is

busy. Otherwise, the sensor 110 sends a response as the command is received. Additionally, the sensor 110 sends a success notification through the sensor control characteristic to acknowledge the sensor 110 has received the command. The sensor 110 registers the shutdown command. At the next appropriate opportunity (e.g., depending on  
5 the current sensor state, as described herein), the sensor 110 will shut down.

*L. Exemplary Sensor States and Activation*

[0207] For purpose of illustration and not limitation, reference is made to the exemplary embodiment of a high-level depiction of a state machine representation 6000 of the actions that can be taken by the sensor 110 as shown in FIG. 15. After initialization, the sensor  
10 enters state 6005, which relates to the manufacture of the sensor 110. In the manufacture state 6005 the sensor 110 can be configured for operation, for example, the storage memory 5030 can be written. At various times while in state 6005, the sensor 110 checks for a received command to go to the storage state 6015. Upon entry to the storage state 6015, the sensor performs a software integrity check. While in the storage state 6015, the  
15 sensor can also receive an activation request command before advancing to the insertion detection state 6025.

[0208] Upon entry to state 6025, the sensor 110 can store information relating to devices authenticated to communicate with the sensor as set during activation or initialize algorithms related to conducting and interpreting measurements from the sensing hardware  
20 5060. The sensor 110 can also initialize a lifecycle timer, responsible for maintaining an active count of the time of operation of the sensor 110 and begin communication with authenticated devices to transmit recorded data. While in the insertion detection state 6025, the sensor can enter state 6030, where the sensor 110 checks whether the time of operation is equal to a predetermined threshold. This time of operation threshold can correspond to  
25 a timeout function for determining whether an insertion has been successful. If the time of operation has reached the threshold, the sensor 110 advances to state 6035, in which the sensor 110 checks whether the average data reading is greater than a threshold amount corresponding to an expected data reading volume for triggering detection of a successful insertion. If the data reading volume is lower than the threshold while in state 6035, the  
30 sensor advances to state 6040, corresponding to a failed insertion. If the data reading volume satisfies the threshold, the sensor advances to the active paired state 6055.

[0209] The active paired state 6055 of the sensor 110 reflects the state while the sensor 110 is operating as normal by recording measurements, processing the measurements, and reporting them as appropriate. While in the active paired state 6055, the sensor 110 sends

measurement results or attempts to establish a connection with a receiving device 120. The sensor 110 also increments the time of operation. Once the sensor 110 reaches a predetermined threshold time of operation (e.g., once the time of operation reaches a predetermined threshold), the sensor 110 transitions to the active expired state 6065. The active expired state 6065 of the sensor 110 reflects the state while the sensor 110 has operated for its maximum predetermined amount of time.

[0210] While in the active expired state 6065, the sensor 110 can generally perform operations relating to winding down operation and ensuring that the collected measurements have been securely transmitted to receiving devices as needed. For example, while in the active expired state 6065, the sensor 110 can transmit collected data and, if no connection is available, can increase efforts to discover authenticated devices nearby and establish a connection therewith. While in the active expired state 6065, the sensor 110 can receive a shutdown command at state 6070. If no shutdown command is received, the sensor 110 can also, at state 6075, check if the time of operation has exceeded a final operation threshold. The final operation threshold can be based on the battery life of the sensor 110. The normal termination state 6080 corresponds to the final operations of the sensor 110 and ultimately shutting down the sensor 110.

[0211] Before a sensor is activated, the ASIC 5000 resides in a low power storage mode state. The activation process can begin, for example, when an incoming RF field (e.g., NFC field) drives the voltage of the power supply to the ASIC 5000 above a reset threshold, which causes the sensor 110 to enter a wake-up state. While in the wake-up state, the ASIC 5000 enters an activation sequence state. The ASIC 5000 then wakes the communication module 5040. The communication module 5040 is initialized, triggering a power on self-test. The power on self-test can include the ASIC 5000 communicating with the communication module 5040 using a prescribed sequence of reading and writing data to verify the memory and one-time programmable memory are not corrupted.

[0212] When the ASIC 5000 enters the measurement mode for the first time, an insertion detection sequence is performed to verify that the sensor 110 has been properly installed onto the patient's body before a proper measurement can take place. First, the sensor 110 interprets a command to activate the measurement configuration process, causing the ASIC 5000 to enter measurement command mode. The sensor 110 then temporarily enters the measurement lifecycle state to run a number of consecutive measurements to test whether the insertion has been successful. The communication module 5040 or ASIC 5000 evaluates the measurement results to determine insertion success. When insertion is



deemed successful, the sensor 110 enters a measurement state, in which the sensor 110 begins taking regular measurements using sensing hardware 5060. If the sensor 110 determines that the insertion was not successful, sensor 110 is triggered into an insertion failure mode, in which the ASIC 5000 is commanded back to storage mode while the communication module 5040 disables itself.

*M. Exemplary Over-the-Air Updates*

[0213] FIG. 1B further illustrates an example operating environment for providing over-the-air (“OTA”) updates for use with the techniques described herein. An operator of the analyte monitoring system 100 can bundle updates for the data receiving device 120 or sensor 110 into updates for an application executing on the multi-purpose data receiving device 130. Using available communication channels between the data receiving device 120, the multi-purpose data receiving device 130, and the sensor 110, the multi-purpose data receiving device 130 can receive regular updates for the data receiving device 120 or sensor 110 and initiate installation of the updates on the data receiving device 120 or sensor 110. The multi-purpose data receiving device 130 acts as an installation or update platform for the data receiving device 120 or sensor 110 because the application that enables the multi-purpose data receiving device 130 to communicate with an analyte sensor 110, data receiving device 120 and/or remote application server 150 can update software or firmware on a data receiving device 120 or sensor 110 without wide-area networking capabilities.

[0214] As embodied herein, a remote application server 150 operated by the manufacturer of the analyte sensor 110 and/or the operator of the analyte monitoring system 100 can provide software and firmware updates to the devices of the analyte monitoring system 100. In particular embodiments, the remote application server 150 can provide the updated software and firmware to a user device 140 or directly to a multi-purpose data receiving device. As embodied herein, the remote application server 150 can also provide application software updates to an application storefront server 160 using interfaces provided by the application storefront. The multi-purpose data receiving device 130 can contact the application storefront server 160 periodically to download and install the updates.

[0215] After the multi-purpose data receiving device 130 downloads an application update including a firmware or software update for a data receiving device 120 or sensor 110, the data receiving device 120 or sensor 110 and multi-purpose data receiving device 130 establish a connection. The multi-purpose data receiving device 130 determines that a firmware or software update is available for the data receiving device 120 or sensor 110.

The multi-purpose data receiving device 130 can prepare the software or firmware update for delivery to the data receiving device 120 or sensor 110. As an example, the multi-purpose data receiving device 130 can compress or segment the data associated with the software or firmware update, can encrypt or decrypt the firmware or software update, or  
5 can perform an integrity check of the firmware or software update. The multi-purpose data receiving device 130 sends the data for the firmware or software update to the data receiving device 120 or sensor 110. The multi-purpose data receiving device 130 can also send a command to the data receiving device 120 or sensor 110 to initiate the update. Additionally or alternatively, the multi-purpose data receiving device 130 can provide a  
10 notification to the user of the multi-purpose data receiving device 130 and include instructions for facilitating the update, such as instructions to keep the data receiving device 120 and the multi-purpose data receiving device 130 connected to a power source and in close proximity until the update is complete.

[0216] The data receiving device 120 or sensor 110 receives the data for the update and  
15 the command to initiate the update from the multi-purpose data receiving device 130. The data receiving device 120 can then install the firmware or software update. To install the update, the data receiving device 120 or sensor 110 can place or restart itself in a so-called "safe" mode with limited operational capabilities. Once the update is completed, the data receiving device 120 or sensor 110 re-enters or resets into a standard operational mode.  
20 The data receiving device 120 or sensor 110 can perform one or more self-tests to determine that the firmware or software update was installed successfully. The multi-purpose data receiving device 130 can receive the notification of the successful update. The multi-purpose data receiving device 130 can then report a confirmation of the successful update to the remote application server 150.

[0217] In particular embodiments, the storage memory 5030 of the sensor 110 includes  
25 one-time programmable (OTP) memory. The term OTP memory can refer to memory that includes access restrictions and security to facilitate writing to particular addresses or segments in the memory a predetermined number of times. The memory 5030 can be prearranged into multiple pre-allocated memory blocks or containers. The containers are  
30 pre-allocated into a fixed size. If storage memory 5030 is one-time programming memory, the containers can be considered to be in a non-programmable state. Additional containers which have not yet been written to can be placed into a programmable or writable state. Containerizing the storage memory 5030 in this fashion can improve the transportability of code and data to be written to the storage memory 5030. Updating the software of a

device (e.g., the sensor device described herein) stored in an OTP memory can be performed by superseding only the code in a particular previously-written container or containers with updated code written to a new container or containers, rather than replacing the entire code in the memory. In a second embodiment, the memory is not prearranged. Instead, the space allocated for data is dynamically allocated or determined as needed. Incremental updates can be issued, as containers of varying sizes can be defined where updates are anticipated.

[0218] FIG. 16 is a diagram illustrating an example operational and data flow for over-the-air (OTA) programming of a storage memory 5030 in a sensor device 100 as well as use of the memory after the OTA programming in execution of processes by the sensor device 110 according to the disclosed subject matter. In the example OTA programming 500 illustrated in FIG. 5, a request is sent from an external device (e.g., the data receiving device 130) to initiate OTA programming (or re-programming). At 511, a communication module 5040 of a sensor device 110 receives an OTA programming command. The communication module 5040 sends the OTA programming command to the microcontroller 5010 of the sensor device 110.

[0219] At 531, after receiving the OTA programming command, the microcontroller 5010 validates the OTA programming command. The microcontroller 5010 can determine, for example, whether the OTA programming command is signed with an appropriate digital signature token. Upon determining that the OTA programming command is valid, the microcontroller 5010 can set the sensor device into an OTA programming mode. At 532, the microcontroller 5010 can validate the OTA programming data. At 533, The microcontroller 5010 can reset the sensor device 110 to re-initialize the sensor device 110 in a programming state. Once the sensor device 110 has transitioned into the OTA programming state, the microcontroller 5010 can begin to write data to the rewriteable memory 540 (e.g., memory 5020) of the sensor device at 534 and write data to the OTP memory 550 of the sensor device at 535 (e.g., storage memory 5030). The data written by the microcontroller 5010 can be based on the validated OTA programming data. The microcontroller 5010 can write data to cause one or more programming blocks or regions of the OTP memory 550 to be marked invalid or inaccessible. The data written to the free or unused portion of the OTP memory can be used to replace invalidated or inaccessible programming blocks of the OTP memory 550. After the microcontroller 5010 writes the data to the respective memories at 534 and 535, the microcontroller 5010 can perform one or more software integrity checks to ensure that errors were not introduced into the

programming blocks during the writing process. Once the microcontroller 5010 is able to determine that the data has been written without errors, the microcontroller 5010 can resume standard operations of the sensor device.

5 [0220] In execution mode, at 536, the microcontroller 5010 can retrieve a programming manifest or profile from the rewriteable memory 540. The programming manifest or profile can include a listing of the valid software programming blocks and can include a guide to program execution for the sensor 110. By following the programming manifest or profile, the microcontroller 5010 can determine which memory blocks of the OTP memory 550 are appropriate to execute and avoid execution of out-of-date or invalidated programming blocks or reference to out-of-date data. At 537, the microcontroller 5010 can selectively retrieve memory blocks from the OTP memory 550. At 538, the microcontroller 5010 can use the retrieved memory blocks, by executing programming code stored or using variable stored in the memory.

*N. Exemplary Security and Other Architecture Features*

15 [0221] As embodied herein a first layer of security for communications between the analyte sensor 110 and other devices can be established based on security protocols specified by and integrated in the communication protocols used for the communication. Another layer of security can be based on communication protocols that necessitate close proximity of communicating devices. Furthermore, certain packets and/or certain data included within packets can be encrypted while other packets and/or data within packets is otherwise encrypted or not encrypted. Additionally or alternatively, application layer encryption can be used with one or more block ciphers or stream ciphers to establish mutual authentication and communication encryption with other devices in the analyte monitoring system 100.

25 [0222] The ASIC 5000 of the analyte sensor 110 can be configured to dynamically generate authentication and encryption keys using data retained within the storage memory 5030. The storage memory 5030 can also be pre-programmed with a set of valid authentication and encryption keys to use with particular classes of devices. The ASIC 5000 can be further configured to perform authentication procedures with other devices using received data and apply the generated key to sensitive data prior to transmitting the sensitive data. The generated key can be unique to the analyte sensor 110, unique to a pair of devices, unique to a communication session between an analyte sensor 110 and other device, unique to a message sent during a communication session, or unique to a block of data contained within a message.

[0223] Both the sensor 110 and a data receiving device 120 can ensure the authorization of the other party in a communication session to, for example, issue a command or receive data. In particular embodiments, identity authentication can be performed through two features. First, the party asserting its identity provides a validated certificate signed by the manufacturer of the device or the operator of the analyte monitoring system 100. Second, authentication can be enforced through the use of public keys and private keys, and shared secrets derived therefrom, established by the devices of the analyte monitoring system 100 or established by the operator of the analyte monitoring system 100. To confirm the identity of the other party, the party can provide proof that the party has control of its private key.

[0224] The manufacturer of the analyte sensor 110, data receiving device 120, or provider of the application for multi-purpose data receiving device 130 can provide information and programming necessary for the devices to securely communicate through secured programming and updates. For example, the manufacturer can provide information that can be used to generate encryption keys for each device, including secured root keys for the analyte sensor 110 and optionally for the data receiving device 120 that can be used in combination with device-specific information and operational data (e.g., entropy-based random values) to generate encryption values unique to the device, session, or data transmission as need.

[0225] Analyte data associated with a user is sensitive data at least in part because this information can be used for a variety of purposes, including for health monitoring and medication dosing decisions. In addition to user data, the analyte monitoring system 100 can enforce security hardening against efforts by outside parties to reverse-engineering. Communication connections can be encrypted using a device-unique or session-unique encryption key. Encrypted communications or unencrypted communications between any two devices can be verified with transmission integrity checks built into the communications. Analyte sensor 110 operations can be protected from tampering by restricting access to read and write functions to the memory 5020 via a communication interface. The sensor can be configured to grant access only to known or “trusted” devices, provided in a “whitelist” or only to devices that can provide a predetermined code associated with the manufacturer or an otherwise authenticated user. A whitelist can represent an exclusive range, meaning that no connection identifiers besides those included in the whitelist will be used, or a preferred range, in which the whitelist is searched first, but other devices can still be used. The sensor 110 can further deny and shut down

connection requests if the requestor cannot complete a login procedure over a communication interface within a predetermined period of time (*e.g.*, within four seconds). These characteristics safeguard against specific denial of service attacks, and in particular against denial of service attacks on a BLE interface.

5 [0226] As embodied herein, the analyte monitoring system 100 can employ periodic key rotation to further reduce the likelihood of key compromise and exploitation. A key rotation strategy employed by the analyte monitoring system 100 can be designed to support backward compatibility of field-deployed or distributed devices. As an example, the analyte monitoring system 100 can employ keys for downstream devices (*e.g.*, devices  
10 that are in the field or cannot be feasibly provided updates) that are designed to be compatible with multiple generations of keys used by upstream devices.

[0227] For purpose of illustration and not limitation, reference is made to the exemplary embodiment of a message sequence diagram 600 for use with the disclosed subject matter as shown in FIG. 17 and demonstrating an example exchange of data between a pair of  
15 devices, particularly a sensor 110 and a data receiving device 120. The data receiving device 120 can, as embodied herein, be a data receiving device 120 or a multi-purpose data receiving device 130. At step 605, the data receiving device 120 can transmit a sensor activation command 605 to the sensor 110, for example via a short-range communication protocol. The sensor 110 can, prior to step 605 be in a primarily dormant state, preserving  
20 its battery until full activation is needed. After activation during step 610, the sensor 110 can collect data or perform other operations as appropriate to the sensing hardware 5060 of the sensor 110. At step 615 the data receiving device 120 can initiate an authentication request command 615. In response to the authentication request command 615, both the sensor 110 and data receiving device 120 can engage in a mutual authentication process  
25 620. The mutual authentication process 620 can involve the transfer of data, including challenge parameters that allow the sensor 110 and data receiving device 120 to ensure that the other device is sufficiently capable of adhering to an agreed-upon security framework described herein. Mutual authentication can be based on mechanisms for authentication of two or more entities to each other with or without on-line trusted third  
30 parties to verify establishment of a secret key via challenge-response. Mutual authentication can be performed using two-, three-, four-, or five-pass authentication, or similar versions thereof.

[0228] Following a successful mutual authentication process 620, at step 625 the sensor 110 can provide the data receiving device 120 with a sensor secret 625. The sensor secret

can contain sensor-unique values and be derived from random values generated during manufacture. The sensor secret can be encrypted prior to or during transmission to prevent third-parties from accessing the secret. The sensor secret 625 can be encrypted via one or more of the keys generated by or in response to the mutual authentication process 620. At step 630, the data receiving device 120 can derive a sensor-unique encryption key from the sensor secret. The sensor-unique encryption key can further be session-unique. As such, the sensor-unique encryption key can be determined by each device without being transmitted between the sensor 110 or data receiving device 120. At step 635, the sensor 110 can encrypt data to be included in payload. At step 640, the sensor 110 can transmit the encrypted payload 640 to the data receiving device 120 using the communication link established between the appropriate communication models of the sensor 110 and data receiving device 120. At step 645, the data receiving device 120 can decrypt the payload using the sensor-unique encryption key derived during step 630. Following step 645, the sensor 110 can deliver additional (including newly collected) data and the data receiving device 120 can process the received data appropriately.

[0229] As discussed herein, the sensor 110 can be a device with restricted processing power, battery supply, and storage. The encryption techniques used by the sensor 110 (e.g., the cipher algorithm or the choice of implementation of the algorithm) can be selected based at least in part on these restrictions. The data receiving device 120 can be a more powerful device with fewer restrictions of this nature. Therefore, the data receiving device 120 can employ more sophisticated, computationally intense encryption techniques, such as cipher algorithms and implementations.

#### *O. Exemplary Payload / Communication Frequencies*

[0230] The analyte sensor 110 can be configured to alter its discoverability behavior to attempt to increase the probability of the receiving device receiving an appropriate data packet and/or provide an acknowledgement signal or otherwise reduce restrictions that can be causing an inability to receive an acknowledgement signal. Altering the discoverability behavior of the analyte sensor 110 can include, for example and without limitation, altering the frequency at which connection data is included in a data packet, altering how frequently data packets are transmitted generally, lengthening or shortening the broadcast window for data packets, altering the amount of time that the analyte sensor 110 listens for acknowledgement or scan signals after broadcasting, including directed transmissions to one or more devices (e.g., through one or more attempted transmissions) that have previously communicated with the analyte sensor 110 and/or to one or more devices on a

whitelist, altering a transmission power associated with the communication module when broadcasting the data packets (*e.g.*, to increase the range of the broadcast or decrease energy consumed and extend the life of the battery of the analyte sensor), altering the rate of preparing and broadcasting data packets, or a combination of one or more other alterations. Additionally, or alternatively, the receiving device can similarly adjust parameters relating to the listening behavior of the device to increase the likelihood of receiving a data packet including connection data.

[0231] As embodied herein, the analyte sensor 110 can be configured to broadcast data packets using two types of windows. The first window refers to the rate at which the analyte sensor 110 is configured to operate the communication hardware. The second window refers to the rate at which the analyte sensor 110 is configured to be actively transmitting data packets (*e.g.*, broadcasting). As an example, the first window can indicate that the analyte sensor 110 operates the communication hardware to send and/or receive data packets (including connection data) during the first 2 seconds of each 60 second period. The second window can indicate that, during each 2 second window, the analyte sensor 110 transmits a data packet every 60 milliseconds. The rest of the time during the 2 second window, the analyte sensor 110 is scanning. The analyte sensor 110 can lengthen or shorten either window to modify the discoverability behavior of the analyte sensor 110.

[0232] In particular embodiments, the discoverability behavior of the analyte sensor can be stored in a discoverability profile, and alterations can be made based on one or more factors, such as the status of the analyte sensor 110 and/or by applying rules based on the status of the analyte sensor 110. For example, when the battery level of the analyte sensor 110 is below a certain amount, the rules can cause the analyte sensor 110 to decrease the power consumed by the broadcast process. As another example, configuration settings associated with broadcasting or otherwise transmitting packets can be adjusted based on the ambient temperature, the temperature of the analyte sensor 110, or the temperature of certain components of communication hardware of the analyte sensor 110. In addition to modifying the transmission power, other parameters associated with the transmission capabilities or processes of the communication hardware of the analyte sensor 110 can be modified, including, but not limited to, transmission rate, frequency, and timing. As another example, when the analyte data indicates that the subject is, or is about to be, experiencing a negative health event, the rules can cause the analyte sensor 110 to increase its discoverability to alert the receiving device of the negative health event.



*P. Exemplary Sensor Sensitivity Initialization / Adjustment Features*

[0233] As embodied herein, certain calibration features for the sensing hardware 5060 of the analyte sensor 110 can be adjusted based on external or interval environment features as well as to compensate for the decay of the sensing hardware 5060 during expended  
5 period of disuse (e.g., a “shelf time” prior to use). The calibration features of the sensing hardware 5060 can be autonomously adjusted by the sensor 110 (e.g., by operation of the ASIC 5000 to modify features in the memory 5020 or storage 5030) or can be adjusted by other devices of the analyte monitoring system 100.

[0234] As an example, sensor sensitivity of the sensing hardware 5060 can be adjusted  
10 based on external temperature data or the time since manufacture. When external temperatures are monitored during the storage of the sensors, the disclosed subject matter can adaptively change the compensation to sensor sensitivity over time when the device experiences changing storage conditions. For purpose of illustration not limitations, adaptive sensitivity adjustment can be performed in an “active” storage mode where the  
15 analyte sensor 110 wakes up periodically to measure temperature. These features can save the battery of the analyte device and extend the lifespan of the analyte sensors. At each temperature measurement, the analyte sensor 110 can calculate a sensitivity adjustment for that time period based on the measured temperature. Then, the temperature-weighted adjustments can be accumulated over the active storage mode period to calculate a total  
20 sensor sensitivity adjustment value at the end of the active storage mode (e.g., at insertion). Similarly, at insertion, the sensor 110 can determine the time difference between manufacture of the sensor 110 (which can be written to the storage 5030 of the ASIC 5000) or the sensing hardware 5060 and modify sensor sensitivity or other calibration features according to one or more known decay rates or formulas.

[0235] Additionally, for purpose of illustration and not limitation, as embodied herein, sensor sensitivity adjustments can account for other sensor conditions, such as sensor drift. Sensor sensitivity adjustments can be hardcoded into the sensor 110 during manufacture, for example in the case of sensor drift, based on an estimate of how much an average  
25 sensor would drift. Sensor 110 can use a calibration function that has time-varying  
30 functions for sensor offset and gain, which can account for drift over a wear period of the sensor. Thus, sensor 110 can utilize a function used to transform an interstitial current to interstitial glucose utilizing device-dependent functions describing sensor 110 drift over time, and which can represent sensor sensitivity, and can be device specific, combined with a baseline of the glucose profile. Such functions to account for sensor sensitivity and

drift can improve sensor 110 accuracy over a wear period and without involving user calibration.

*Q. Exemplary Model-based Analyte Measurements*

[0236] The sensor 110 detects raw measurement values from sensing hardware 5060. On-  
5 sensor processing can be performed, such as by one or more models trained to interpret  
the raw measurement values. Models can be machine learned models trained off-device to  
detect, predict, or interpret the raw measurement values to detect, predict, or interpret the  
levels of one or more analytes. Additional trained models can operate on the output of the  
machine learning models trained to interact with raw measurement values. As an example,  
10 models can be used to detect, predict, or recommend events based on the raw  
measurements and type of analyte(s) detected by the sensing hardware 5060. Events can  
include, initiation or completion of physical activity, meals, application of medical  
treatment or medication, emergent health events, and other events of a similar nature.

[0237] Models can be provided to the sensor 110, data receiving device 120, or multi-  
15 purpose data receiving device 130 during manufacture or during firmware or software  
updates. Models can be periodically refined, such as by the manufacturer of the sensor 110  
or the operator of the analyte monitoring system 100, based on data received from the  
sensor 110 and data receiving devices of an individual user or multiple users collectively.  
In certain embodiments, the sensor 110 includes sufficient computational components to  
20 assist with further training or refinement of the machine learned models, such as based on  
unique features of the user to which the sensor 110 is attached. Machine learning models  
can include, by way of example and not limitation, models trained using or encompassing  
decision tree analysis, gradient boosting, ada boosting, artificial neural networks or  
variants thereof, linear discriminant analysis, nearest neighbor analysis, support vector  
25 machines, supervised or unsupervised classification, and others. The models can also  
include algorithmic or rules-based models in addition to machine learned models. Model-  
based processing can be performed by other devices, including the data receiving device  
120 or multi-purpose data receiving device 130, upon receiving data from the sensor 110  
(or other downstream devices).

*R. Exemplary Alarm Features*

[0238] Data transmitted between the sensor 110 and a data receiving device 120 can  
include raw or processed measurement values. Data transmitted between the sensor 110  
and data receiving device 120 can further include alarms or notification for display to a  
user. The data receiving device 120 can display or otherwise convey notifications to the

user based on the raw or processed measurement values or can display alarms when received from the sensor 110. Alarms that may be triggered for display to the user include alarms based on direct analyte values (e.g., one-time reading exceeding a threshold or failing to satisfy a threshold), analyte value trends (e.g., average reading over a set period of time exceeding a threshold or failing to satisfy a threshold; slope); analyte value predictions (e.g., algorithmic calculation based on analyte values exceeds a threshold or fails to satisfy a threshold), sensor alerts (e.g., suspected malfunction detected), communication alerts (e.g., no communication between sensor 110 and data receiving device 120 for a threshold period of time; unknown device attempting or failing to initiate a communication session with the sensor 110), reminders (e.g., reminder to charge data receiving device 120; reminder to take a medication or perform other activity), and other alerts of a similar nature. For purpose of illustration and not limitation, as embodied herein, the alarm parameters described herein can be configurable by a user or can be fixed during manufacture, or combinations of user-settable and non-user-settable parameters.

15 *S. Exemplary Electrode Configurations*

[0239] Sensor configurations featuring a single active area that is configured for the detection of a corresponding single analyte can employ two-electrode or three-electrode detection motifs, as described further herein in reference to FIGS. 18A-18C. Sensor configurations featuring two different active areas for detection of the same or separate analytes, either upon separate working electrodes or upon the same working electrode, are described separately thereafter in reference to FIGS. 19A-21C. Sensor configurations having multiple working electrodes can be particularly advantageous for incorporating two different active areas within the same sensor tail, since the signal contribution from each active area can be determined more readily.

25 [0240] When a single working electrode is present in an analyte sensor, three-electrode sensor configurations can include a working electrode, a counter electrode, and a reference electrode. Related two-electrode sensor configurations can include a working electrode and a second electrode, in which the second electrode can function as both a counter electrode and a reference electrode (i.e., a counter/reference electrode). The various electrodes can be at least partially stacked (layered) upon one another and/or laterally spaced apart from one another upon the sensor tail. Suitable sensor configurations can be substantially flat in shape or substantially cylindrical in shape or any other suitable shape. In any of the sensor configurations disclosed herein, the various electrodes can be electrically isolated from one another by a dielectric material or similar insulator.

[0241] Analyte sensors featuring multiple working electrodes can similarly include at least one additional electrode. When one additional electrode is present, the one additional electrode can function as a counter/reference electrode for each of the multiple working electrodes. When two additional electrodes are present, one of the additional electrodes  
5 can function as a counter electrode for each of the multiple working electrodes and the other of the additional electrodes can function as a reference electrode for each of the multiple working electrodes.

[0242] FIG. 18A shows a diagram of an illustrative two-electrode analyte sensor configuration, which is compatible for use in the disclosure herein. As shown, analyte  
10 sensor 200 includes substrate 30212 disposed between working electrode 214 and counter/reference electrode 30216. Alternately, working electrode 214 and counter/reference electrode 30216 can be located upon the same side of substrate 30212 with a dielectric material interposed in between (configuration not shown). Active area 218 is disposed as at least one layer upon at least a portion of working electrode 214.  
15 Active area 218 can include multiple spots or a single spot configured for detection of an analyte, as discussed further herein. In certain embodiments, active area 218 is configured to detect potassium as described herein.

[0243] Referring still to FIG. 18A, membrane 220 overcoats at least active area 218. In certain embodiments, membrane 220 can also overcoat some or all of working electrode  
20 214 and/or counter/reference electrode 30216, or the entirety of analyte sensor 200. One or both faces of analyte sensor 200 can be overcoated with membrane 220. Membrane 220 can include one or more polymeric membrane materials having capabilities of limiting analyte flux to active area 218 (*i.e.*, membrane 220 is a mass transport limiting membrane having some permeability for the analyte of interest). According to the disclosure herein,  
25 and further described below, membrane 220 can be crosslinked with a branched crosslinker in certain particular sensor configurations. For example, but not by way of limitation, membrane 220 is crosslinked with a crosslinking agent described herein, *e.g.*, a branched glycidyl ether. The composition and thickness of membrane 220 can vary to promote a desired analyte flux to active area 218, thereby providing a desired signal  
30 intensity and stability. Analyte sensor 200 can be operable for assaying an analyte, *e.g.*, potassium, by any of coulometric, amperometric, voltammetric, or potentiometric electrochemical detection techniques.

[0244] FIGS. 18B and 18C show diagrams of illustrative three-electrode analyte sensor configurations, which are also compatible for use in the disclosure herein. Three-electrode

analyte sensor configurations can be similar to that shown for analyte sensor 200 in FIG. 18A, except for the inclusion of additional electrode 217 in analyte sensors 201 and 202 (FIGS. 18B and 18C). With additional electrode 217, counter/reference electrode 30216 can then function as either a counter electrode or a reference electrode, and additional electrode 217 fulfills the other electrode function not otherwise accounted for. Working electrode 214 continues to fulfill its original function. Additional electrode 217 can be disposed upon either working electrode 214 or electrode 30216, with a separating layer of dielectric material in between. For example, and not by the way of limitation, as depicted in FIG. 18B, dielectric layers 219a, 219b and 219c separate electrodes 214, 30216 and 217 from one another and provide electrical isolation. Alternatively, at least one of electrodes 214, 30216 and 217 can be located upon opposite faces of substrate 30212, as shown in FIG. 18C. Thus, in certain embodiments, electrode 214 (working electrode) and electrode 30216 (counter electrode) can be located upon opposite faces of substrate 30212, with electrode 217 (reference electrode) being located upon one of electrodes 214 or 30216 and spaced apart therefrom with a dielectric material. Reference material layer 230 (e.g., Ag/AgCl) can be present upon electrode 217, with the location of reference material layer 230 not being limited to that depicted in FIGS. 18B and 18C. As with sensor 200 shown in FIG. 18A, active area 218 in analyte sensors 201 and 202 can include multiple spots or a single spot. Additionally, analyte sensors 201 and 202 can be operable for assaying an analyte, e.g., potassium, by any of coulometric, amperometric, voltammetric or potentiometric electrochemical detection techniques.

[0245] Like analyte sensor 200, membrane 220 can also overcoat active area 218, as well as other sensor components, in analyte sensors 201 and 202, thereby serving as a mass transport limiting membrane. In certain embodiments, the additional electrode 217 can be overcoated with membrane 220. Although FIGS. 18B and 18C have depicted electrodes 214, 30216 and 217 as being overcoated with membrane 220, it is to be recognized that in certain embodiments only working electrode 214 is overcoated. Moreover, the thickness of membrane 220 at each of electrodes 214, 30216 and 217 can be the same or different. As in two-electrode analyte sensor configurations (FIG. 18A), one or both faces of analyte sensors 201 and 202 can be overcoated with membrane 220 in the sensor configurations of FIGS. 18B and 18C, or the entirety of analyte sensors 201 and 202 can be overcoated. Accordingly, the three-electrode sensor configurations shown in FIGS. 18B and 18C should be understood as being non-limiting of the embodiments disclosed herein, with alternative electrode and/or layer configurations remaining within the scope of the present

disclosure.

[0246] FIG. 19A shows an illustrative configuration for sensor 203 having a single working electrode with two different active areas disposed thereon. FIG. 19A is similar to FIG. 18A, except for the presence of two active areas upon working electrode 214: first active area 218a and second active area 218b, which are responsive to the same or different analytes and are laterally spaced apart from one another upon the surface of working electrode 214. Active areas 218a and 218b can include multiple spots or a single spot configured for detection of each analyte. The composition of membrane 220 can vary or be compositionally the same at active areas 218a and 218b. First active area 218a and second active area 218b can be configured to detect their corresponding analytes at working electrode potentials that differ from one another, as discussed further below. In certain embodiments, any one of active areas 218a and 218b, or both, can be configured to detect potassium. In certain embodiments, any one of active areas 218a and 218b, or both, can be configured to detect potassium by using aspartate oxidase. In certain embodiments, any one of active areas 218a and 218b, or both, can be configured to detect potassium by using aspartate oxidase and asparaginase. In certain embodiments, only one active area of 218a and 218b is configured to detect potassium. In certain embodiments, the other active area is configured to detect a second analyte that is different from potassium. Non-limiting examples of second analytes are described herein.

[0247] FIGS. 19B and 19C show cross-sectional diagrams of illustrative three-electrode sensor configurations for sensors 204 and 205, respectively, each featuring a single working electrode having first active area 218a and second active area 218b disposed thereon. FIGS. 19B and 19C are otherwise similar to FIGS. 18B and 18C and can be better understood by reference thereto. As with FIG. 19A, the composition of membrane 220 can vary or be compositionally the same at active areas 218a and 218b.

[0248] Illustrative sensor configurations having multiple working electrodes, specifically two working electrodes, are described in further detail in reference to FIGS. 20-21C. Although the following description is primarily directed to sensor configurations having two working electrodes, it is to be appreciated that more than two working electrodes can be incorporated through extension of the disclosure herein. Additional working electrodes can be used to impart additional sensing capabilities to the analyte sensors beyond just a first analyte and a second analyte, *e.g.*, for the detection of a third and/or fourth analyte.

[0249] FIG. 20 shows a cross-sectional diagram of an illustrative analyte sensor configuration having two working electrodes, a reference electrode and a counter

electrode, which is compatible for use in the disclosure herein. As shown, analyte sensor 300 includes working electrodes 304 and 306 disposed upon opposite faces of substrate 302. First active area 310a is disposed upon the surface of working electrode 304, and second active area 310b is disposed upon the surface of working electrode 306. Counter electrode 320 is electrically isolated from working electrode 304 by dielectric layer 322, and reference electrode 321 is electrically isolated from working electrode 306 by dielectric layer 323. Outer dielectric layers 30230 and 332 are positioned upon reference electrode 321 and counter electrode 320, respectively. Membrane 340 can overcoat at least active areas 310a and 310b, according to various embodiments, with other components of analyte sensor 300 or the entirety of analyte sensor 300 optionally being overcoated with membrane 340. In certain embodiments, membrane 340 can be continuous but vary compositionally within first membrane portion 340a and second membrane portion 340b (*i.e.*, upon active areas 310a and 310b) in order to afford different permeability values for differentially regulating the analyte flux at each location. For example, but not by way of limitation, a first membrane portion 340a can overcoat at least active area 310a and a second membrane portion 340b can overcoat at least active area 310b, according to various embodiments, with other components of analyte sensor 300 or the entirety of analyte sensor 300.

[0250] In certain embodiments, different membrane formulations can be sprayed and/or printed onto the opposing faces of analyte sensor 300. Dip coating techniques can also be appropriate, particularly for depositing at least a portion of a bilayer membrane upon one of active areas 310a and 310b. In certain embodiments, membrane 340 can be the same or vary compositionally at active areas 310a and 310b. For example, but not by way of limitation, membrane 340 can include a bilayer overcoating active area 310a and be a homogeneous membrane overcoating active area 310b, or membrane 340 can include a bilayer overcoating active areas 310b and be a homogeneous membrane overcoating active area 310a. In certain embodiments, one of the first membrane portion 340a and the second membrane portion 340b can comprise a bilayer membrane and the other of the first membrane portion 340a and the second membrane portion 340b can comprise a single membrane polymer, according to particular embodiments of the present disclosure. In certain embodiments, an analyte sensor can include more than one membrane 340, *e.g.*, two or more membranes. For example, but not by way of limitation, an analyte sensor can include a membrane that overcoats the one or more active areas, *e.g.*, 310a and 310b, and an additional membrane that overcoats the entire sensor as shown in FIG. 20. In such

configurations, a bilayer membrane can be formed over the one or more active areas, *e.g.*, 310a and 310b.

[0251] In certain embodiments, any one of active areas 310a and 310b, or both, can be configured to detect potassium, *e.g.*, by using an aspartate oxidase. In certain  
5 embodiments, any one of active areas 310a and 310b, or both, can further comprise an asparaginase. In certain embodiments, only one active area of 310a and 310b is configured to detect potassium, *e.g.*, by using an aspartate oxidase. In certain embodiments, only one active area of 310a and 310b can further comprise an asparaginase. In certain  
embodiments, the other active area is configured to detect a second analyte.

10 [0252] Alternative sensor configurations having multiple working electrodes and differing from the configuration shown in FIG. 20 can feature a counter/reference electrode instead of separate counter and reference electrodes 320, 321, and/or feature layer and/or  
membrane arrangements varying from those expressly depicted. For example, and not by the way of limitation the positioning of counter electrode 320 and reference electrode 321  
15 can be reversed from that depicted in FIG. 20. In addition, working electrodes 304 and 306 need not necessarily reside upon opposing faces of substrate 302 in the manner shown in FIG. 20.

[0253] Although suitable sensor configurations can feature electrodes that are substantially planar in character, it is to be appreciated that sensor configurations featuring  
20 non-planar electrodes can be advantageous and particularly suitable for use in the disclosure herein. In particular, substantially cylindrical electrodes that are disposed concentrically with respect to one another can facilitate deposition of a mass transport limiting membrane, as described hereinbelow. In particular, concentric working  
electrodes that are spaced apart along the length of a sensor tail can facilitate membrane  
25 deposition through sequential dip coating operations, in a similar manner to that described above for substantially planar sensor configurations. FIGS. 21A-21C show perspective views of analyte sensors featuring two working electrodes that are disposed concentrically with respect to one another. It is to be appreciated that sensor configurations having a concentric electrode disposition but lacking a second working electrode are also possible  
30 in the present disclosure.

[0254] FIG. 21A shows a perspective view of an illustrative sensor configuration in which multiple electrodes are substantially cylindrical and are disposed concentrically with respect to one another about a central substrate. As shown, analyte sensor 400 includes central substrate 402 about which all electrodes and dielectric layers are disposed



concentrically with respect to one another. In particular, working electrode 410 is disposed upon the surface of central substrate 402, and dielectric layer 412 is disposed upon a portion of working electrode 410 distal to sensor tip 404. Working electrode 420 is disposed upon dielectric layer 412, and dielectric layer 422 is disposed upon a portion of working electrode 420 distal to sensor tip 404. Counter electrode 430 is disposed upon dielectric layer 422, and dielectric layer 432 is disposed upon a portion of counter electrode 430 distal to sensor tip 404. Reference electrode 440 is disposed upon dielectric layer 432, and dielectric layer 442 is disposed upon a portion of reference electrode 440 distal to sensor tip 404. As such, exposed surfaces of working electrode 410, working electrode 420, counter electrode 430, and reference electrode 440 are spaced apart from one another along longitudinal axis B of analyte sensor 400.

[0255] Referring still to FIG. 21A, first active areas 414a and second active areas 414b, which are responsive to different analytes or the same analyte, are disposed upon the exposed surfaces of working electrodes 410 and 420, respectively, thereby allowing contact with a fluid to take place for sensing. Although active areas 414a and 414b have been depicted as three discrete spots in FIG. 21A, it is to be appreciated that fewer or greater than three spots, including a continuous layer of active area, can be present in alternative sensor configurations as described herein. In certain embodiments, any one of active areas 414a and 414b, or both, can be configured to detect potassium. In certain embodiments, any one of active areas 414a and 414b, or both, can be configured to detect potassium by using an enzyme system comprising an aspartate oxidase and, optionally, an asparaginase. In certain embodiments, only one active area of 414a and 414b is configured to detect potassium. In certain embodiments, only one active area of 414a and 414b is configured to detect potassium by using an aspartate oxidase and, optionally, an asparaginase. In certain embodiments, the other active area is configured to detect a second analyte.

[0256] In FIG. 21A, sensor 400 is partially coated with membrane 450 upon working electrodes 410 and 420 and active areas 414a and 414b disposed thereon. FIG. 21B shows an alternative sensor configuration in which the substantial entirety of sensor 401 is overcoated with membrane 450. Membrane 450 can be the same or vary compositionally at active areas 414a and 414b. For example, membrane 450 can include a bilayer overcoating active areas 414a and be a homogeneous membrane overcoating active areas 414b.

[0257] It is to be further appreciated that the positioning of the various electrodes in FIGS. 21A and 21B can differ from that expressly depicted. For example, the positions of counter electrode 430 and reference electrode 440 can be reversed from the depicted configurations in FIGS. 21A and 21B. Similarly, the positions of working electrodes 410 and 420 are not limited to those that are expressly depicted in FIGS. 21A and 21B. FIG. 21C shows an alternative sensor configuration to that shown in FIG. 21B, in which sensor 405 contains counter electrode 430 and reference electrode 440 that are located more proximal to sensor tip 404 and working electrodes 410 and 420 that are located more distal to sensor tip 404. Sensor configurations in which working electrodes 410 and 420 are located more distal to sensor tip 404 can be advantageous by providing a larger surface area for deposition of active areas 414a and 414b (five discrete sensing spots illustratively shown in FIG. 21C), thereby facilitating an increased signal strength in some cases. Similarly, central substrate 402 can be omitted in any concentric sensor configuration disclosed herein, wherein the innermost electrode can instead support subsequently deposited layers.

[0258] In certain embodiments, one or more electrodes of an analyte sensor described herein is a wire electrode, *e.g.*, a permeable wire electrode. In certain embodiments, the sensor tail comprises a working electrode and a reference electrode helically wound around the working electrode. In certain embodiments, an insulator is disposed between the working and reference electrodes. In certain embodiments, portions of the electrodes are exposed to allow reaction of the one or more enzymes with an analyte on the electrode. In certain embodiments, each electrode is formed from a fine wire with a diameter of from about 0.001 inches or less to about 0.010 inches or more. In certain embodiments, the working electrode has a diameter of from about 0.001 inches or less to about 0.010 inches or more, *e.g.*, from about 0.002 inches to about 0.008 inches, and more preferably from about 0.004 inches to about 0.005 inches. In certain embodiments, an electrode is formed from a plated insulator, a plated wire or bulk electrically conductive material. In certain embodiments, the working electrode comprises a wire formed from a conductive material, such as platinum, platinum-iridium, palladium, graphite, gold, carbon, conductive polymer, alloys or the like. In certain embodiments, the conductive material is a permeable conductive material. In certain embodiments, the electrodes can be formed by a variety of manufacturing techniques (*e.g.*, bulk metal processing, deposition of metal onto a substrate or the like), the electrodes can be formed from plated wire (*e.g.*, platinum on steel wire) or bulk metal (*e.g.*, platinum wire). In certain embodiments, the electrode is formed from tantalum wire, *e.g.*, coated in a conductive material.

[0259] In certain embodiments, the reference electrode, which can function as a reference electrode alone, or as a dual reference and counter electrode, is formed from silver, silver/silver chloride or the like. In certain embodiments, the reference electrode is juxtaposed and/or twisted with or around the working electrode. In certain embodiments, the reference electrode is helically wound around the working electrode. In certain embodiments, the assembly of wires can be coated or adhered together with an insulating material so as to provide an insulating attachment.

[0260] In certain embodiments, additional electrodes, *e.g.*, wire electrodes, can be included in the sensor tail. For example, but not by way of limitation, a three-electrode system (a working electrode, a reference electrode and a counter electrode) and/or an additional working electrode (*e.g.*, an electrode for detecting a second analyte) can be included in the sensor tail. In certain embodiments where the sensor comprises two working electrodes, the two working electrodes can be juxtaposed around which the reference electrode is disposed upon (*e.g.*, helically wound around the two or more working electrodes). In certain embodiments, the two or more working electrodes can extend parallel to each other. In certain embodiments, the reference electrode is coiled around the one or more working electrodes and extends towards the distal end (*i.e.*, *in vivo* end) of the sensor tail. In certain embodiments, the reference electrode extends (*e.g.*, helically) to the exposed region of the one or more working electrodes.

[0261] In certain embodiments, one or more working electrodes are helically wound around a reference electrode. In certain embodiments where two or more working electrodes are provided, the working electrodes can be formed in a double-, triple-, quad-, etc. helix configuration along the length of the sensor tail (for example, surrounding a reference electrode, insulated rod or other support structure). In certain embodiments, the electrodes, *e.g.*, two or more working electrodes, are coaxially formed. For example, but not by way limitation, the electrodes all share the same central axis.

[0262] In certain embodiments, the working electrode comprises a tube with a reference electrode disposed or coiled inside, including an insulator therebetween. Alternatively, the reference electrode comprises a tube with a working electrode disposed or coiled inside, including an insulator therebetween. In certain embodiments, a polymer (*e.g.*, insulating) rod is provided, wherein the one or more electrodes (*e.g.*, one or more electrode layers) are disposed upon (*e.g.*, by electro-plating). In certain embodiments, a metallic (*e.g.*, steel or tantalum) rod or wire is provided, coated with an insulating material (described herein), onto which the one or more working and reference electrodes are disposed upon. For

example, but not by way of limitation, the present disclosure provides a sensor, *e.g.*, a sensor tail, that comprises one or more tantalum wires, where a conductive material is disposed upon a portion of the one or more tantalum wires to function as a working electrode. In certain embodiments, the platinum-clad tantalum wire is covered with an insulating material, where the insulating material is partially covered with a silver/silver chloride composition to function as a reference and/or counter electrode.

5 [0263] In certain embodiments where an insulator is disposed upon the working electrode (*e.g.*, upon the platinum surface of the electrode), a portion of the insulator can be stripped or otherwise removed to expose the electroactive surface of the working electrode. For example, but not by way of limitation, a portion of the insulator can be removed by hand, excimer lasing, chemical etching, laser ablation, grit-blasting or the like. Alternatively, a portion of the electrode can be masked prior to depositing the insulator to maintain an exposed electroactive surface area. In certain embodiments, the portion of the insulator that is stripped and/or removed can be from about 0.1 mm (about 0.004 inches) or less to about 2 mm (about 0.078 inches) or more in length, *e.g.*, from about 0.5 mm (about 0.02 inches) to about 0.75 mm (0.03 inches) in length. In certain embodiments, the insulator is a non-conductive polymer. In certain embodiments, the insulator comprises parylene, fluorinated polymers, polyethylene terephthalate, polyvinylpyrrolidone, polyurethane, polyimide and other non-conducting polymers. In certain embodiments, glass or ceramic materials can also be used in the insulator layer. In certain embodiments, the insulator comprises parylene. In certain embodiments, the insulator comprises a polyurethane. In certain embodiments, the insulator comprises a polyurethane and polyvinylpyrrolidone.

20 [0264] Several parts of the sensor, including the active areas, are further described below.

## 2. *Enzymes*

25 [0265] An active area of a presently disclosed analyte sensor can be configured for detecting an analyte. In certain embodiments, the presently disclosed analyte sensors are configured to measure potassium, *e.g.*, potassium ions, in a sample. For example, but not by way of limitation, an active area of a presently disclosed analyte sensor is configured to detect potassium ions.

30 [0266] In certain embodiments, the presently disclosed analyte sensors are configured to indirectly detect potassium ions by comparing signals obtained from at least one, *e.g.*, at least two, aspartate-responsive active areas. In certain embodiments, the current signal from the two aspartate-responsive active areas can be correlated to the concentration of potassium ions, as discussed below.

[0267] In certain embodiments, the presently disclosed analyte sensors are configured to indirectly detect potassium ions by comparing signals obtained from at least one, *e.g.*, at least two, asparagine-responsive active areas. In certain embodiments, the current signal from the two asparagine-responsive active areas can be correlated to the concentration of potassium ions, as discussed below.

[0268] In certain embodiments, an active area of the present disclosure is disposed upon a portion of a working electrode. For example, but not by way of limitation, an active area is disposed upon a portion of the working electrode in a spotted pattern, *e.g.*, two or more spots on the working electrode. In certain embodiments, an active area is disposed upon a portion of the working electrode in a slotted pattern. In certain embodiments, an active area is disposed upon the entire length of the working electrode or in a continuous pattern on the working electrode.

[0269] In certain embodiments, an active area of the present disclosure can have a thickness from about 0.1  $\mu\text{m}$  to about 100  $\mu\text{m}$ , *e.g.*, from about 1  $\mu\text{m}$  to about 90  $\mu\text{m}$ , from about 1  $\mu\text{m}$  to about 80  $\mu\text{m}$ , from about 1  $\mu\text{m}$  to about 70  $\mu\text{m}$ , from about 1  $\mu\text{m}$  to about 60  $\mu\text{m}$ , from about 1  $\mu\text{m}$  to about 50  $\mu\text{m}$ , from about 1  $\mu\text{m}$  to about 40  $\mu\text{m}$ , from about 1  $\mu\text{m}$  to about 30  $\mu\text{m}$ , from about 1  $\mu\text{m}$  to about 20  $\mu\text{m}$ , from about 0.5  $\mu\text{m}$  to about 10  $\mu\text{m}$ , from about 1  $\mu\text{m}$  to about 10  $\mu\text{m}$ , from about 1  $\mu\text{m}$  to about 5  $\mu\text{m}$  or from about 0.1  $\mu\text{m}$  to about 5  $\mu\text{m}$ . In certain embodiments, an active area of the present disclosure has an area of about 0.01  $\text{mm}^2$  to about 2.0  $\text{mm}^2$ , *e.g.*, about 0.1  $\text{mm}^2$  to about 1.0  $\text{mm}^2$  or about 0.2  $\text{mm}^2$  to about 0.5  $\text{mm}^2$ .

[0270] It is to be appreciated that the sensitivity (output current) of the analyte sensors toward each analyte can be varied by changing the coverage (area or size) of the active areas, the area ratio of the active areas with respect to one another, the identity, thickness and/or composition of a mass transport limiting membrane overcoating the active areas. Variation of these parameters can be conducted readily by one having ordinary skill in the art once granted the benefit of the disclosure herein.

#### A. Aspartate-Responsive Active Areas

[0271] In certain embodiments, an analyte sensor of the present disclosure includes at least one active area, *e.g.*, two active areas, configured to detect aspartate to facilitate indirect measurement of potassium ion concentration in a sample. A particular enzyme that can be used for detecting aspartate is shown in FIG. 27. In certain embodiments, the enzyme present in the aspartate-responsive active area is an aspartate oxidase. As shown in FIG. 27, aspartate oxidase can catalyze the oxidation of aspartate to oxaloacetate and the

reduction of its coenzyme flavin adenine dinucleotide (FAD) to FADH<sub>2</sub>. An electron transfer agent can then mediate the electron transfer from FADH<sub>2</sub> to the working electrode. The electrochemical signal obtained at the working electrode can then be correlated to the amount of potassium ions that was initially present in the sample.

5 [0272] Particular examples of aspartate oxidases suitable for use in the analyte sensors disclosed herein include, but are not limited to, potassium-dependent and potassium-independent aspartate oxidases. In certain embodiments, the aspartate oxidase used in the enzyme system is potassium-dependent. For example, but not by way of limitation, the activity of the aspartate oxidase is dependent on potassium ion concentration thereby  
10 allowing the indirect determination of potassium levels in sample. In certain other embodiments, the aspartate oxidase used in the enzyme system is potassium-independent. Non-limiting examples of an aspartate oxidase for use in the present disclosure include L-aspartate oxidases from a species of the genera *Thermococcus*, *Pyrococcus*, *Sulfolobus* and *Halobacteria*. In certain embodiments, the L-aspartate oxidase is from *Sulfolobus*  
15 *tokodaii* or *Thermococcus litoralis*. For example, but not by way of limitation, L-aspartate oxidases for use in the potassium sensors of the present disclosure are disclosed in Nasu et al., *J. of Biological Chemistry* 257(2):626-32 (1982); Bifulco et al., *Appl. Microbiol. Biotechnol.* 97(16):7285-95 (2013); Washio et al., *Extremophiles* 22(1):59-71 (2018); and Hao et al., *Plant Science* 271:133-142 (2018), the contents of each of which are  
20 incorporated herein by reference in their entireties.

[0273] In certain embodiments, the aspartate-responsive active area can include an aspartate oxidase, e.g., a potassium-independent aspartate oxidase or a potassium-independent aspartate oxidase. In certain embodiments, the aspartate-responsive active area active area can include an enzyme system consisting essentially of  
25 an aspartate oxidase. In certain embodiments, the aspartate-responsive active area active area can include an enzyme system consisting of an aspartate oxidase. In certain embodiments, an aspartate-responsive active area can include by weight from about 10% to about 80%, e.g., from about 15% to about 75%, from about 20% to about 70%, from about 25% to about 65%, from about 20% to about 60%, from about 20% to about 55%,  
30 from about 20% to about 50%, from about 20% to about 45%, from about 20% to about 40%, from about 20% to about 35% or from about 20% to about 30% of an aspartate oxidase. In certain embodiments, an active area can include by weight from about 10% to about 40% of an aspartate oxidase. In certain embodiments, an aspartate-responsive active area can include by weight from about 15% to about 35% of an aspartate oxidase. In

certain embodiments, an asparagine-responsive active area can include by weight from about 20% to about 30% of an aspartate oxidase.

[0274] In certain embodiments, the aspartate-responsive active area can further include a stabilizer. In certain embodiments, the stabilizer is used for enzyme stabilization. For example, but not by way of limitation, the stabilizer can be an albumin, *e.g.*, a serum albumin. Non-limiting examples of serum albumins include a bovine serum albumin and a human serum albumin. In certain embodiments, the stabilizer is a human serum albumin. In certain embodiments, the stabilizer is a bovine serum albumin. In certain embodiments, the aspartate-responsive active area can include a ratio of stabilizer to aspartate oxidase from about 40:1 to about 1:40, *e.g.*, from about 35:1 to about 1:35, from about 30:1 to about 1:30, from about 25:1 to about 1:25, from about 20:1 to about 1:20, from about 15:1 to about 1:15, from about 10:1 to about 1:10, from about 9:1 to about 1:9, from about 8:1 to about 1:8, from about 7:1 to about 1:7, from about 6:1 to about 1:6, from about 5:1 to about 1:5, from about 4:1 to about 1:4, from about 3:1 to about 1:3, from about 2:1 to about 1:2 or about 1:1. In certain embodiments, the aspartate-responsive active area can include a ratio of stabilizing agent to aspartate oxidase from about 5:1 to about 1:5. In certain embodiments, the aspartate-responsive active area can include a ratio of stabilizing agent to aspartate oxidase from about 4:1 to about 1:4. In certain embodiments, the aspartate-responsive active area can include a ratio of stabilizing agent to aspartate oxidase from about 3:1 to about 1:3. In certain embodiments, the aspartate-responsive active area can include a ratio of stabilizing agent to aspartate oxidase from about 2:1 to about 1:2.

[0275] In certain embodiments, an analyte sensor of the present disclosure for indirect measurement of potassium can include a first potassium-dependent channel comprising a first aspartate-responsive active area and a second potassium-dependent channel comprising a second aspartate-responsive active area. In certain embodiments, each channel is a working electrode. In certain embodiments, the first potassium-dependent channel includes a first potassium-dependent aspartate oxidase. In certain embodiments, the second potassium-dependent channel includes a second potassium-dependent aspartate oxidase. In such embodiments, the first potassium-dependent aspartate oxidase and the second potassium-dependent aspartate oxidase exhibit different dependencies on potassium and would, therefore, result in different signals in the presence of the same potassium concentration. In certain embodiments, the difference in signals obtained from the first potassium-dependent channel and the second potassium-dependent channel can be correlated to the concentration of the potassium ions in the sample.

[0276] In certain embodiments, an analyte sensor of the present disclosure for indirect measurement of potassium can include a first potassium-dependent channel and a second potassium-dependent channel. In certain embodiments, each channel is a working electrode. In certain embodiments, the first potassium-dependent channel 801 includes a  
5 first potassium-dependent aspartate oxidase. In certain embodiments, the second potassium-dependent channel includes a second potassium-dependent aspartate oxidase. In such embodiments, the first potassium-dependent aspartate oxidase and the second potassium-dependent aspartate oxidase exhibit different dependencies on potassium and would, therefore, result in different signals in the presence of the same potassium  
10 concentration. In certain embodiments, the difference in signals obtained from the two channels can be correlated to the concentration of the potassium ions in the sample.

[0277] In certain embodiments, an analyte sensor of the present disclosure can include a sensor tail including at least two working electrodes. In certain embodiments, an aspartate-responsive active area (*e.g.*, a first aspartate-responsive active area) is disposed upon the  
15 surface of the first working electrode and an aspartate-responsive active area (*e.g.*, a second aspartate-responsive active area) is disposed upon the surface of the second working electrode, where each aspartate-responsive active area includes an aspartate oxidase. In certain embodiments, the first aspartate-responsive active area includes a potassium-independent aspartate oxidase and the second aspartate-responsive active area  
20 includes a potassium-dependent aspartate oxidase. Alternatively, the first aspartate-responsive active area includes a first potassium-dependent aspartate oxidase and the second aspartate-responsive active area includes a second potassium-dependent aspartate oxidase, where the aspartate oxidases have different dependencies on potassium ion concentration.

#### 25 *B. Asparagine-Responsive Active Areas*

[0278] In certain embodiments, an analyte sensor of the present disclosure includes at least one active area, *e.g.*, two active areas, configured to detect asparagine to facilitate indirect measurement of potassium ion concentration in a sample. A particular enzyme system that can be used for detecting asparagine is shown in FIG. 22. As shown in FIG. 22,  
30 asparaginase catalyzes the hydrolysis of asparagine to produce aspartate. Aspartate oxidase can then catalyze the oxidation of aspartate to oxaloacetate and the reduction of its coenzyme flavin adenine dinucleotide (FAD) to FADH<sub>2</sub>. An electron transfer reagent can then mediate the electron transfer from FADH<sub>2</sub> to the working electrode.



[0279] Particular examples of asparaginases suitable for use in the analyte sensors disclosed herein include, but are not limited to, potassium-dependent and potassium-independent asparaginases. In certain embodiments, the asparaginase used in the enzyme system is potassium-dependent. In certain other embodiments, the asparaginase used in the enzyme system is potassium-independent. Non-limiting examples of potassium-independent and potassium-dependent asparaginases are disclosed in Ajewole et al., FEBS Journal 285(8):1528-1539 (2018) and Bejger et al., Acta Crystallogr. D. Biol. Crystallogr. 70(Pt 7):1854-72 (2014), the contents of which are incorporated herein by reference in their entireties. In certain embodiments, an asparaginase for use in the present disclosure is the potassium-dependent (PvAspG1) and/or potassium-independent (PvAspG-T2) asparaginases from *Phaseolus vulgaris*. In certain embodiments, the asparaginase includes a substitution of the amino acid at position 118 or position 117 of PvAspG1 and PvAspG-T2, respectively.

[0280] In certain embodiments, the asparagine-responsive active area can include an enzyme system comprising an aspartate oxidase and an asparaginase. In certain embodiments, the asparagine-responsive active area can include an enzyme system consisting essentially of an aspartate oxidase and an asparaginase. In certain embodiments, the asparagine-responsive active area can include an enzyme system consisting of an aspartate oxidase and an asparaginase. In certain embodiments, an asparagine-responsive active area can include a ratio of aspartate oxidase to asparaginase from about 100:1 to about 1:100, e.g., from about 95:1 to about 1:95, from about 90:1 to about 1:90, from about 85:1 to about 1:85, from about 80:1 to about 1:80, from about 75:1 to about 1:75, from about 60:1 to about 1:60, from about 55:1 to about 1:55, from about 50:1 to about 1:50, from about 45:1 to about 1:45, from about 40:1 to about 1:40, from about 35:1 to about 1:35, from about 30:1 to about 1:30, from about 25:1 to about 1:25, from about 20:1 to about 1:20, from about 15:1 to about 1:15, from about 10:1 to about 1:10, from about 9:1 to about 1:9, from about 8:1 to about 1:8, from about 7:1 to about 1:7, from about 6:1 to about 1:6, from about 5:1 to about 1:5, from about 4:1 to about 1:4, from about 3:1 to about 1:3 or from about 2:1 to about 1:2. In certain embodiments, an asparagine-responsive active area can include a ratio of aspartate oxidase to asparaginase from about 90:1 to about 1:90. In certain embodiments, an asparagine-responsive active area can include a ratio of aspartate oxidase to asparaginase from about 100:1 to about 2:1. In certain embodiments, an asparagine-responsive active area can include a ratio of aspartate oxidase to asparaginase from about 100:1 to about 50:1. In certain embodiments,

an asparagine-responsive active area can include a ratio of aspartate oxidase to asparaginase from about 90:1 to about 70:1. In certain embodiments, an asparagine-responsive active area, can include by weight from about 0.1% to about 80%, *e.g.*, from about 0.1% to about 75%, from about 0.1% to about 70%, from about 0.1% to about 65%,  
5 from about 0.1% to about 60%, from about 0.1% to about 55%, from about 0.1% to about 50%, from about 0.1% to about 45%, from about 0.1% to about 40%, from about 0.1% to about 35%, from about 0.1% to about 30%, from about 0.1% to about 25%, from about 0.1% to about 20%, from about 0.1% to about 15%, from about 0.1% to about 10%, from about 0.1% to about 5%, from about 15% to about 75%, from about 20% to about 70%,  
10 from about 25% to about 65%, from about 20% to about 60%, from about 20% to about 55%, from about 20% to about 50%, from about 20% to about 45%, from about 20% to about 40%, from about 20% to about 35% or from about 20% to about 30%, of one or more enzymes, *e.g.*, aspartate oxidase and/or asparaginase. In certain embodiments, an active area can include by weight from about 0.1% to about 40% of one or more enzymes,  
15 *e.g.*, aspartate oxidase and/or asparaginase. In certain embodiments, an active area can include by weight from about 1% to about 40% of one or more enzymes, *e.g.*, aspartate oxidase and/or asparaginase. In certain embodiments, an active area can include by weight from about 1% to about 35% of one or more enzymes, *e.g.*, aspartate oxidase and/or asparaginase. In certain embodiments, an active area can include by weight from about  
20 1% to about 30% of one or more enzymes, *e.g.*, aspartate oxidase and/or asparaginase. In certain embodiments, an active area can include by weight from about 1% to about 25% of one or more enzymes, *e.g.*, aspartate oxidase and/or asparaginase. In certain embodiments, an asparagine-responsive can include by weight from about 15% to about 35% of one or more enzymes, *e.g.*, aspartate oxidase and/or asparaginase. In certain  
25 embodiments, an asparagine-responsive include by weight from about 20% to about 30% of one or more enzymes, *e.g.*, aspartate oxidase and/or asparaginase.

[0281] In certain embodiments, the asparagine-responsive active area can further include a stabilizer, *e.g.*, for stabilizing the enzyme. For example, but not by way of limitation, the stabilizer can be an albumin, *e.g.*, a serum albumin. Non-limiting examples of serum  
30 albumins include bovine serum albumin and human serum albumin. In certain embodiments, the stabilizer is a human serum albumin. In certain embodiments, the stabilizer is a bovine serum albumin. In certain embodiments, the asparagine-responsive active area can include a ratio of stabilizing agent to asparaginase and/or aspartate oxidase from about 40:1 to about 1:40, *e.g.*, from about 35:1 to about 1:35, from about 30:1 to

about 1:30, from about 25:1 to about 1:25, from about 20:1 to about 1:20, from about 15:1 to about 1:15, from about 10:1 to about 1:10, from about 9:1 to about 1:9, from about 8:1 to about 1:8, from about 7:1 to about 1:7, from about 6:1 to about 1:6, from about 5:1 to about 1:5, from about 4:1 to about 1:4, from about 3:1 to about 1:3, from about 2:1 to about 1:2 or about 1:1. In certain embodiments, the asparagine-responsive active area can include a ratio of stabilizing agent to asparaginase and/or aspartate oxidase from about 5:1 to about 1:5. In certain embodiments, the asparagine-responsive active area can include a ratio of stabilizing agent to asparaginase and/or aspartate oxidase from about 4:1 to about 1:4. In certain embodiments, the asparagine-responsive active area can include a ratio of stabilizing agent to asparaginase and/or aspartate oxidase from about 3:1 to about 1:3. In certain embodiments, the asparagine-responsive active area can include a ratio of stabilizing agent to asparaginase and/or aspartate oxidase from about 2:1 to about 1:2. In certain embodiments, the asparagine-responsive active area can include a ratio of stabilizing agent to asparaginase and/or aspartate oxidase of about 1:1. In certain embodiments, an active area, e.g., an aspartate-responsive active area and/or an asparagine-responsive active area, can include by weight from about 10% to about 50%, e.g., from about 15% to about 45%, from about 20% to about 40%, from about 20% to about 35%, from about 20% to about 30%, of the stabilizing agent. In certain embodiments, asparagine-responsive active area can include by weight from about 15% to about 35% of the stabilizer.

[0282] In certain embodiments, an analyte sensor of the present disclosure for indirect measurement of potassium is shown in FIG. 23. As shown in FIG. 23, the analyte sensor can include a potassium-dependent channel 701 and a potassium-independent channel 702. In certain embodiments, each channel is a working electrode. In certain embodiments, the potassium-dependent channel 701 includes an enzyme system that comprises a potassium-dependent asparaginase. In certain embodiments, the potassium-independent channel 702 includes an enzyme system that comprises a potassium-independent asparaginase. In certain embodiments, the potassium-dependent asparaginase is a wild-type form of an asparaginase and the potassium-independent asparaginase is a mutant form of the same asparaginase. In certain embodiments, the current signals obtained from channels 701 and 702 can be compared to obtain the concentration of the potassium ions in the sample.

[0283] In certain embodiments, an analyte sensor of the present disclosure for indirect measurement of potassium is shown in FIG. 24. As shown in FIG. 24, the analyte sensor can include a first potassium-dependent channel 801 and a second potassium-dependent

channel 802. In certain embodiments, each channel is a working electrode. In certain embodiments, the first potassium-dependent channel 801 includes an enzyme system that comprises a first potassium-dependent asparaginase. In certain embodiments, the second potassium-dependent channel 802 includes an enzyme system that comprises a second potassium-dependent asparaginase. In such embodiments, the first potassium-dependent asparaginase and the second potassium-dependent asparaginase exhibit different dependencies on potassium and would, therefore, result in different signals in the presence of the same potassium concentration. In certain embodiments, the difference in signals obtained from channels 801 and 802 can be correlated to the concentration of the potassium ions in the sample.

[0284] In certain embodiments, the potassium ion concentration using an analyte sensor comprising the enzyme systems of FIG. 23 or FIG. 24 can be determined as shown in FIGS. 25A and 25B. For example, but not by way of limitation, in the absence of potassium ions, each of the channels (*e.g.*, each of channels 801 and 802) has a linear response to increasing asparagine concentrations, as shown in 25A, which can be described by the following equations:

$$I_1 = k_1 C \quad [1]$$

$$I_2 = k_2 C \quad [2]$$

where  $I_1$  and  $I_2$  correspond to the current output,  $C$  is asparagine concentration and  $k_1$  and  $k_2$  correspond to the slope of the lines of the two channels. The two constants  $k_1$  and  $k_2$  can be obtained from a standard dose-responding calibration in a beaker with different levels of asparagine.

[0285] FIG. 25B illustrates the sensor response in the presence of increasing potassium ion concentration. As shown in FIG. 25B, the current response is non-linear and can be described by the following equations:

$$I'_1 = f_1(K) + I_{1-0} \quad [3]$$

$$I'_2 = f_2(K) + I_{2-0} \quad [4]$$

where  $I'_1$  and  $I'_2$  correspond to the current output,  $I_{1-0}$  and  $I_{2-0}$  correspond to the sensor response when potassium ion concentration is zero. It should also be noted that:

$$\frac{I_{1-0}}{I_{2-0}} = \frac{k_1}{k_2} \quad [5]$$

In order to determine the concentration of potassium ions in the sample, the system of equations 3-5 have to be solved. This system consists of three (3) equations with three (3) unknowns, including potassium concentration,  $I_{1-0}$  and  $I_{2-0}$ .

[0286] In certain embodiments, the asparagine-responsive active area can include an asparaginase, *e.g.*, a potassium-independent asparaginase or a potassium-dependent asparaginase. In certain embodiments, the asparagine-responsive active area can further include an aspartate oxidase, *e.g.*, a potassium-independent aspartate oxidase.

5 Alternatively, an asparagine-responsive active area comprising an asparaginase, *e.g.*, a potassium-independent asparaginase or a potassium-dependent asparaginase, can be disposed upon an aspartate-responsive active area as described above in Section 2A.

[0287] In certain embodiments, an analyte sensor of the present disclosure can include a sensor tail including at least two working electrodes. In certain embodiments, an  
10 asparagine-responsive active area (*e.g.*, a first asparagine-responsive active area) is disposed upon the surface of the first working electrode and an asparagine-responsive active area (*e.g.*, a second asparagine-responsive active area) is disposed upon the surface of the second working electrode, where each asparagine-responsive active area includes an enzyme system including an aspartate oxidase and an asparaginase. In certain  
15 embodiments, the first asparagine-responsive active area includes a potassium-independent asparaginase and the second asparagine-responsive active area includes a potassium-dependent asparaginase. Alternatively, the first asparagine-responsive active area includes a first potassium-dependent asparaginase and the second asparagine-responsive active area includes a second potassium-dependent asparaginase, where the  
20 asparaginases have different dependencies on potassium ion concentration.

[0288] In certain embodiments, an asparagine-responsive active area includes a first enzymatic layer that includes the aspartate oxidase and a second layer disposed upon the first enzymatic layer that includes an asparaginase. Alternatively or additionally, the aspartate oxidase and asparaginase are retained within the same enzymatic layer.

25 *C. Active Areas Responsive to Additional Analytes*

[0289] In certain embodiments, an analyte sensor of the present disclosure can include an active area for detecting a second analyte. For example, but not by way of limitation, an analyte sensor can be configured to detect potassium and a second analyte. Non-limiting examples of second analytes include glutamate, glucose, ketones, lactate, oxygen,  
30 hemoglobin A1C, albumin, alcohol, alkaline phosphatase, alanine transaminase, aspartate aminotransferase, bilirubin, blood urea nitrogen, calcium, carbon dioxide, chloride, creatinine, hematocrit, lactate, magnesium, oxygen, pH, phosphorus, potassium, sodium, aspartate, asparagine, total protein, uric acid, etc. In certain embodiments, such analyte sensors can include a third working electrode configured to detect a different analyte by

comprising an analyte-responsive active area disposed upon a surface of a third working electrode.

[0290] In certain embodiments, the active site present on a third working electrode of an analyte sensor of the present disclosure can include one or more enzymes that can be used to detect glucose. For example, but not by way of limitation, an analyte sensor of the present disclosure can include an active area that comprises one or more enzymes for detecting glucose, *e.g.*, disposed on a third working electrode. In certain embodiments, the analyte sensor can include an active site comprising a glucose oxidase and/or a glucose dehydrogenase for detecting glucose.

[0291] In certain embodiments, the active site present on a third working electrode of an analyte sensor of the present disclosure can include one or more enzymes that can be used to detect ketones. For example, but not by way of limitation, an analyte sensor of the present disclosure can include an active area that comprises one or more enzymes, *e.g.*, an enzyme system, for detecting ketones, *e.g.*, disposed on a third working electrode. In certain embodiments, the analyte sensor can include an active site comprising  $\beta$ -hydroxybutyrate dehydrogenase for detecting ketones. In certain embodiments, the analyte sensor can include an active site comprising  $\beta$ -hydroxybutyrate dehydrogenase and diaphorase for detecting ketones.

[0292] In certain embodiments, the active site present on a third working electrode of an analyte sensor of the present disclosure can include one or more enzymes that can be used to detect lactate. For example, but not by way of limitation, an analyte sensor of the present disclosure can include an active area that comprises one or more enzymes, *e.g.*, an enzyme system, for detecting lactate, *e.g.*, disposed on a third working electrode. In certain embodiments, the analyte sensor can include an active site comprising a lactate dehydrogenase and/or a lactate oxidase.

[0293] In certain embodiments, the active site present on a third working electrode of an analyte sensor of the present disclosure can include one or more enzymes that can be used to detect alcohol. For example, but not by way of limitation, an analyte sensor of the present disclosure can include an active area that comprises one or more enzymes, *e.g.*, an enzyme system, for detecting alcohol, *e.g.*, disposed on a third working electrode. In certain embodiments, the analyte sensor can include an active site comprising an alcohol dehydrogenase.

[0294] In certain embodiments, when the sensor is configured to detect two or more analytes on two different working electrodes, detection of each analyte can include

applying a potential to each working electrode separately, such that separate signals are obtained from each analyte. The signal obtained from each analyte can then be correlated to an analyte concentration through use of a calibration curve or function, or by employing a lookup table. In certain particular embodiments, correlation of the analyte signal to an analyte concentration can be conducted through use of a processor.

### 3. *Redox Mediators*

[0295] In certain embodiments, an analyte sensor disclosed herein can include an electron transfer agent. In certain embodiments, one or more active areas of a presently disclosed analyte sensor can include an electron transfer agent. For example, but not by way of limitation, an analyte sensor disclosed herein can include two active areas, which both include an electron transfer agent. Alternatively, an analyte sensor of the present disclosure can include two or more active areas, where only one active area includes an electron transfer agent.

[0296] In certain embodiments, an analyte sensor of the present disclosure can include at least one aspartate-responsive active area that includes an electron transfer agent. In certain embodiments, an analyte sensor of the present disclosure can include at least one asparagine-responsive active area that includes an electron transfer agent. In certain embodiments, an analyte sensor of the present disclosure can include two aspartate-responsive active areas, where each aspartate-responsive active area includes an electron transfer agent. In certain embodiments, an analyte sensor of the present disclosure can include two asparagine-responsive active areas, where each asparagine-responsive active area includes an electron transfer agent. In certain embodiments, the electron transfer agents in the two asparagine-responsive active areas or the two aspartate-responsive active areas can be the same or different. In certain embodiments, an analyte sensor of the present disclosure can include two or more active areas, where only one active area includes an electron transfer agent, *e.g.*, the asparagine-responsive active area or aspartate-responsive active area.

[0297] Suitable electron transfer agents can facilitate conveyance of electrons to the adjacent working electrode after an analyte undergoes an enzymatic oxidation-reduction reaction within the corresponding active area, thereby generating a current that is indicative of the presence of that particular analyte. The amount of current generated is proportional to the quantity of analyte that is present.

[0298] In certain embodiments, suitable electron transfer agents can include electroreducible and electrooxidizable ions, complexes or molecules (*e.g.*, quinones)

having oxidation-reduction potentials that are a few hundred millivolts above or below the oxidation-reduction potential of the standard calomel electrode (SCE). In certain embodiments, the redox mediators can include osmium complexes and other transition metal complexes, such as those described in U.S. Patent Nos. 6,134,461 and 6,605,200, which are incorporated herein by reference in their entirety. Additional examples of suitable redox mediators include those described in U.S. Patent Nos. 6,736,957, 7,501,053 and 7,754,093, the disclosures of each of which are also incorporated herein by reference in their entirety. Other examples of suitable redox mediators include metal compounds or complexes of ruthenium, osmium, iron (*e.g.*, polyvinylferrocene or hexacyanoferrate), or cobalt, including metallocene compounds thereof, for example. Suitable ligands for the metal complexes can also include, for example, bidentate or higher denticity ligands such as, for example, bipyridine, bimidazole, phenanthroline or pyridyl(imidazole). Other suitable bidentate ligands can include, for example, amino acids, oxalic acid, acetylacetonone, diaminoalkanes, or *o*-diaminoarenes. Any combination of monodentate, bidentate, tridentate, tetradentate or higher denticity ligands can be present in a metal complex, *e.g.*, osmium complex, to achieve a full coordination sphere. In certain embodiments, the electron transfer agent is an osmium complex. In certain embodiments, the electron transfer agent is osmium complexed with bidentate ligands.

[0299] In certain embodiments, electron transfer agents disclosed herein can include suitable functionality to promote covalent bonding to a polymer (also referred to herein as a polymeric backbone) within the active areas as discussed further below. For example, but not by way of limitation, an electron transfer agent for use in the present disclosure can include a polymer-bound electron transfer agent. Suitable non-limiting examples of polymer-bound electron transfer agents include those described in U.S. Patent Nos. 8,444,834, 8,268,143 and 6,605,201, the disclosures of which are incorporated herein by reference in their entirety. In certain embodiments, the electron transfer agent is a bidentate osmium complex bound to a polymer described herein. In certain embodiments, the electron transfer agent is a bidentate osmium complex bound to a polymer described herein, *e.g.*, a polymeric backbone described in Section 4 below. In certain embodiments, the polymer-bound electron transfer agent shown in FIG. 3 of U.S. Patent No. 8,444,834 can be used in a sensor of the present disclosure.

[0300] In certain embodiments, an analyte sensor of the present disclosure for monitoring potassium, *e.g.*, potassium ion, levels can include a sensor tail including at least two or more working electrodes, *e.g.*, a first working electrode and a second working electrode.



In certain embodiments, a first asparagine-responsive active area comprising an asparaginase (*e.g.*, a first asparaginase), an aspartate oxidase and an electron transfer agent is disposed upon a surface of the first working electrode. In certain embodiments, a second asparagine-responsive active area comprising an asparaginase (*e.g.*, a second asparaginase), an aspartate oxidase and an electron transfer agent is disposed upon a surface of the second working electrode. In certain embodiments, the two asparaginases differ in potassium dependency. For example, but not by way of limitation, the first asparaginase can be potassium-dependent and the second asparaginase can be potassium-independent. In certain embodiments, the first asparaginase can be potassium-independent and the second asparaginase can be potassium-dependent. In certain embodiments, the first and second asparaginases are both potassium-dependent but differ in potassium dependency. In certain embodiments, the signals measured from the two asparagine-responsive active areas can be correlated to the concentration of potassium ions in the sample analyzed.

15 **[0301]** In certain embodiments, the asparagine-responsive active area can include a ratio of aspartate oxidase and/or asparaginase to redox mediator from about 100:1 to about 1:100, *e.g.*, from about 95:1 to about 1:95, from about 90:1 to about 1:90, from about 85:1 to about 1:85, from about 80:1 to about 1:80, from about 75:1 to about 1:75, from about 60:1 to about 1:60, from about 55:1 to about 1:55, from about 50:1 to about 1:50, from about 45:1 to about 1:45, from about 40:1 to about 1:40, from about 35:1 to about 1:35, from about 30:1 to about 1:30, from about 25:1 to about 1:25, from about 20:1 to about 1:20, from about 15:1 to about 1:15, from about 10:1 to about 1:10, from about 9:1 to about 1:9, from about 8:1 to about 1:8, from about 7:1 to about 1:7, from about 6:1 to about 1:6, from about 5:1 to about 1:5, from about 4:1 to about 1:4, from about 3:1 to about 1:3, from about 2:1 to about 1:2 or about 1:1. In certain embodiments, the asparagine-responsive active area can include a ratio of aspartate oxidase and/or asparaginase to redox mediator from about 5:1 to about 1:5. In certain embodiments, the asparagine-responsive active area can include a ratio of aspartate oxidase and/or asparaginase to redox mediator from about 4:1 to about 1:4. In certain embodiments, the asparagine-responsive active area can include a ratio of aspartate oxidase and/or asparaginase to redox mediator from about 3:1 to about 1:3. In certain embodiments, the asparagine-responsive active area can include a ratio of aspartate oxidase and/or asparaginase to redox mediator from about 2:1 to about 1:2. In certain embodiments, the asparagine-responsive active area can include a ratio of aspartate oxidase and/or asparaginase to redox mediator of about 1:1.

[0302] In certain embodiments, an analyte sensor of the present disclosure for monitoring potassium, *e.g.*, potassium ion, levels can include a sensor tail including at least two or more working electrodes, *e.g.*, a first working electrode and a second working electrode. In certain embodiments, a first aspartate-responsive active area comprising an aspartate oxidase (*e.g.*, a first aspartate oxidase) and an electron transfer agent (*e.g.*, a first electron transfer agent) is disposed upon a surface of the first working electrode. In certain 5 embodiments, a second aspartate-responsive active area comprising an aspartate oxidase (*e.g.*, a second aspartate oxidase) and an electron transfer agent (*e.g.*, a second electron transfer agent) is disposed upon a surface of the second working electrode. In certain 10 embodiments, the two aspartate oxidases differ in potassium dependency. For example, but not by way of limitation, the first aspartate oxidase can be potassium-dependent and the second aspartate oxidase can be potassium-independent. In certain embodiments, the first aspartate oxidase can be potassium-independent and the second aspartate oxidase can be potassium-dependent. In certain embodiments, the first and second aspartate oxidases 15 are both potassium-dependent but differ in potassium dependency. In certain embodiments, the signals measured from the two aspartate-responsive active areas can be correlated to the concentration of potassium ions in the sample analyzed.

[0303] In certain embodiments, the aspartate-responsive active area can include a ratio of aspartate oxidase to redox mediator from about 100:1 to about 1:100, *e.g.*, from about 95:1 20 to about 1:95, from about 90:1 to about 1:90, from about 85:1 to about 1:85, from about 80:1 to about 1:80, from about 75:1 to about 1:75, from about 60:1 to about 1:60, from about 55:1 to about 1:55, from about 50:1 to about 1:50, from about 45:1 to about 1:45, from about 40:1 to about 1:40, from about 35:1 to about 1:35, from about 30:1 to about 1:30, from about 25:1 to about 1:25, from about 20:1 to about 1:20, from about 15:1 to 25 about 1:15, from about 10:1 to about 1:10, from about 9:1 to about 1:9, from about 8:1 to about 1:8, from about 7:1 to about 1:7, from about 6:1 to about 1:6, from about 5:1 to about 1:5, from about 4:1 to about 1:4, from about 3:1 to about 1:3, from about 2:1 to about 1:2 or about 1:1. In certain embodiments, the aspartate-responsive active area can include a ratio of aspartate oxidase to redox mediator from about 5:1 to about 1:5. In certain 30 embodiments, the aspartate-responsive active area can include a ratio of aspartate oxidase to redox mediator from about 4:1 to about 1:4. In certain embodiments, the aspartate-responsive active area can include a ratio of aspartate oxidase to redox mediator from about 3:1 to about 1:3. In certain embodiments, the aspartate-responsive active area can include a ratio of aspartate oxidase to redox mediator from about 2:1 to about 1:2. In certain

embodiments, the aspartate-responsive active area can include a ratio of aspartate oxidase to redox mediator of about 1:1.

#### 4. *Polymeric Backbone*

[0304] In certain embodiments, one or more active sites for promoting analyte detection  
5 can include a polymer to which an enzyme and/or redox mediator is covalently bound. Any suitable polymeric backbone can be present in the active area for facilitating detection of an analyte through covalent bonding of the enzyme and/or redox mediator thereto. Non-limiting examples of suitable polymers within the active area include polyvinylpyridines, *e.g.*, poly(4-vinylpyridine) or poly(2-vinylpyridine), and polyvinylimidazoles, *e.g.*,  
10 poly(N-vinylimidazole) and poly(1-vinylimidazole), or a copolymer thereof, for example, in which quaternized pyridine groups serve as a point of attachment for the redox mediator or enzyme thereto. Illustrative copolymers that can be suitable for inclusion in the active areas include those containing monomer units such as styrene, acrylamide, methacrylamide, or acrylonitrile, for example. In certain embodiments, the polymer is a  
15 polyvinylpyridine-based polymer. In certain embodiments, the polymer is a polyvinylpyridine or a copolymer thereof. In certain embodiments, the polymer is a copolymer of vinylpyridine and styrene. In certain embodiments, polymers that can be present in an active area include a polyurethane or a copolymer thereof, and/or polyvinylpyrrolidone. Additional non-limiting examples of polymers that can be present  
20 in the active area include, but are not limited to, those described in U.S. Patent 6,605,200, incorporated herein by reference in its entirety, such as poly(acrylic acid), styrene/maleic anhydride copolymer, methylvinylether/maleic anhydride copolymer (GANTREZ polymer), poly(vinylbenzylchloride), poly(allylamine), polylysine, poly(4-vinylpyridine) quaternized with carboxypentyl groups, and poly(sodium 4-styrene sulfonate). In certain  
25 embodiments where the analyte sensor includes two active sites, the polymer within each active area can be the same or different.

[0305] In certain embodiments, when an enzyme system with multiple enzymes is present in a given active area, all of the multiple enzymes can be covalently bonded to the polymer. In certain other embodiments, only a portion of the multiple enzymes is covalently bonded  
30 to the polymer. For example, and not by the way of limitation, one or more enzymes within an enzyme system can be covalently bonded to the polymer and at least one enzyme can be non-covalently associated with the polymer, such that the non-covalently bonded enzyme is physically retained within the polymer. In certain embodiments, an aspartate oxidase and/or an asparaginase can be covalently bonded to a polymer within an analyte-

responsive active area of the disclosed analyte sensors. In certain embodiments, aspartate oxidase can be covalently bonded to a polymer within an asparagine-responsive active area of the disclosed analyte sensors. In certain embodiments, asparaginase can be covalently bonded to a polymer within an asparagine-responsive active area of the disclosed analyte sensors. In certain embodiments, aspartate oxidase can be covalently bonded to the polymer and asparaginase can be non-covalently associated with the polymer. Alternatively, asparaginase can be covalently bonded to the polymer and aspartate oxidase can be non-covalently associated with the polymer. In certain embodiments where one or more enzymes is not covalently bonded, it can be physically retained within the asparagine-responsive active area. In certain embodiments, a membrane overcoating the asparagine-responsive active area can aid in retaining the one or more enzymes within the asparagine-responsive active area while still permitting sufficient inward diffusion of asparagine to permit detection thereof. Suitable membrane polymers for overcoating the analyte-responsive active area are discussed further herein.

5  
10  
15  
20  
[0306] In certain embodiments, when a stabilizer is present in an active area, one or more enzymes within the area can be covalently bonded to the stabilizer. For example, and not by the way of limitation, one or more enzymes, *e.g.*, aspartate oxidase and/or asparaginase, can be covalently bonded to the stabilizer, *e.g.*, albumin, present in the active area. In certain embodiments, an aspartate oxidase present in an active area of the present disclosure can be covalently bonded to the stabilizer. In certain embodiments, an asparaginase present in an active area of the present disclosure can be covalently bonded to the stabilizer.

25  
30  
[0307] In certain particular embodiments, covalent bonding of the one or more enzymes and/or redox mediators to the polymer and/or stabilizer in a given active area can take place via crosslinking introduced by a suitable crosslinking agent. In certain embodiments, crosslinking of the polymer and/or stabilizer to the one or more enzymes and/or redox mediators can reduce the occurrence of delamination of the enzyme compositions from an electrode. Suitable crosslinking agents can include one or more crosslinkable functionalities such as, but not limited to, vinyl, alkoxy, acetoxy, enoxy, oxime, amino, hydroxyl, cyano, halo, acrylate, epoxide and isocyanato groups. In certain embodiments, the crosslinking agent comprises one or more, two or more, three or more or four or more epoxide groups. For example, but not by way of limitation, a crosslinker for use in the present disclosure can include mono-, di-, tri- and tetra-ethylene oxides. In certain embodiments, crosslinking agents for reaction with free amino groups in the enzyme (*e.g.*,

with the free side chain amine in lysine) can include crosslinking agents such as, for example, polyethylene glycol dibutyl ethers, polypropylene glycol dimethyl ethers, polyalkylene glycol allyl methyl ethers, polyethylene glycol diglycidyl ether (PEGDGE) or other polyepoxides, cyanuric chloride, N-hydroxysuccinimide, imidoesters, epichlorohydrin, or derivatized variants thereof. In certain embodiments, the crosslinking agent is PEGDGE, *e.g.*, having an average molecular weight ( $M_n$ ) from about 200 to 1,000, *e.g.*, about 400. In certain embodiments, the crosslinking agent is PEGDGE 400. In certain embodiments, the crosslinking agent can be glutaraldehyde. In certain embodiments, the crosslinking of the enzyme to the polymer is generally intermolecular. In certain embodiments, the crosslinking of the enzyme to the polymer is generally intramolecular.

[0308] In certain embodiments, an active area can include a ratio of crosslinking agent to one or more enzymes, *e.g.*, aspartate oxidase, asparaginase or both, from about 50:1 to about 1:50, *e.g.*, from about 45:1 to about 1:45, from about 40:1 to about 1:40, from about 35:1 to about 1:35, from about 30:1 to about 1:30, from about 25:1 to about 1:25, from about 20:1 to about 1:20, from about 15:1 to about 1:15, from about 10:1 to about 1:10, from about 9:1 to about 1:9, from about 8:1 to about 1:8, from about 7:1 to about 1:7, from about 6:1 to about 1:6, from about 5:1 to about 1:5, from about 4:1 to about 1:4, from about 3:1 to about 1:3, from about 2:1 to about 1:2 or about 1:1. In certain embodiments, an active area can include a ratio of crosslinking agent to one or more enzymes, *e.g.*, aspartate oxidase, asparaginase or both, from about 50:1 to about 1:50. In certain embodiments, an active area can include a ratio of crosslinking agent to one or more enzymes, *e.g.*, aspartate oxidase, asparaginase or both, from about 50:1 to about 30:1. In certain embodiments, an active area can include a ratio of crosslinking agent to one or more enzymes, *e.g.*, aspartate oxidase, asparaginase or both, from about 50:1 to about 1:1. In certain embodiments, an active area can include a ratio of crosslinking agent to one or more enzymes, *e.g.*, aspartate oxidase, asparaginase or both, from about 2:1 to about 1:2. In certain embodiments, an active area can include a ratio of crosslinking agent to one or more enzymes, *e.g.*, aspartate oxidase, asparaginase or both, of about 1:1. In certain embodiments, an active area can include a ratio of crosslinking agent to one or more enzymes, *e.g.*, aspartate oxidase, asparaginase or both, from about 5:1 to about 1:5. In certain embodiments, an active area can include a ratio of crosslinking agent to one or more enzymes, *e.g.*, aspartate oxidase, asparaginase or both, from about 2:1 to about 1:2. In certain embodiments, an active area can include a ratio of crosslinking agent to one or more enzymes, *e.g.*, aspartate oxidase,

asparaginase or both, of about 1:1. In certain embodiments, an active area, *e.g.*, aspartate-responsive active area and/or asparagine-responsive active area, can include by weight from about 5% to about 20%, *e.g.*, from about 10% to about 20% or from about 10% to about 15%, of the crosslinking agent. In certain embodiments, the glutamate-responsive active area can include from about 10% to about 20% of the crosslinking agent.

#### 5. *Mass Transport Limiting Membranes*

[0309] In certain embodiments, the analyte sensors disclosed herein further include a membrane permeable to an analyte that overcoats at least an active area, *e.g.*, a first active area and/or a second active area, present on a working electrode of the analyte sensor. In certain embodiments, the analyte sensors disclosed herein further include a membrane permeable to potassium that overcoats at least an active area, *e.g.*, a first active area and/or a second active area, present on a working electrode of the analyte sensor.

[0310] In certain embodiments, a membrane overcoating an analyte-responsive active area can function as a mass transport limiting membrane and/or to improve biocompatibility. A mass transport limiting membrane can act as a diffusion-limiting barrier to reduce the rate of mass transport of the analyte. For example, but not by way of limitation, limiting access of an analyte, *e.g.*, aspartate, asparagine and/or potassium, to the analyte-responsive active area with a mass transport limiting membrane can aid in avoiding sensor overload (saturation), thereby improving detection performance and accuracy.

[0311] In certain embodiments, the mass transport limiting membrane can be homogeneous and can be single-component (contain a single membrane polymer). Alternatively, the mass transport limiting membrane can be multi-component (contain two or more different membrane polymers). In certain embodiments, the multi-component membrane can be present as a multilayered membrane or as a homogeneous admixture of two or more membrane polymers. A homogeneous admixture can be generated by combining the two or more membrane polymers in a solution and then depositing the solution upon a working electrode, *e.g.*, dip coating. A multilayered membrane can be generated by sequentially depositing membrane polymers upon a working electrode, *e.g.*, dip coating.

[0312] In certain embodiments, the mass transport limiting membrane can include two or more layers, *e.g.*, a bilayer or trilayer membrane. In certain embodiments, each layer can comprise a different polymer or the same polymer at different concentrations or thicknesses. In certain embodiments, the first analyte-responsive active area can be covered by a multi-layered membrane, *e.g.*, a bilayer membrane, and the second analyte-

responsive active area can be covered by a single membrane. In certain embodiments, the first analyte-responsive active area can be covered by a multi-layered membrane, *e.g.*, a bilayer membrane, and the second analyte-responsive active area can be covered by a multi-layered membrane, *e.g.*, a bilayer membrane. In certain embodiments, the first analyte-responsive active area can be covered by a single membrane and the second analyte-responsive active area can be covered by a multi-layered membrane, *e.g.*, a bilayer membrane be covered by a single membrane. In certain embodiments, the first analyte-responsive active area can be covered by a single membrane and the second analyte-responsive active area can be covered by a single membrane.

5  
10 [0313] In certain embodiments, the composition of the mass transport limiting membrane disposed upon an analyte sensor that has two active areas can be the same or different where the mass transport limiting membrane overcoats each active area. For example, but not by way of limitation, the portion of the mass transport limiting membrane overcoating an asparagine-responsive active area or aspartate-responsive active area used for indirect measurement of potassium can be multi-component and/or the portion of the mass transport limiting membrane overcoating a second analyte-responsive active area can be single-component. Alternatively, the portion of the mass transport limiting membrane overcoating an asparagine-responsive active area or aspartate-responsive active area used for indirect measurement of potassium ions can be single-component and/or the portion of the mass transport limiting membrane overcoating a second analyte-responsive active area can be multi-component.

15  
20 [0314] In certain embodiments, a mass transport limiting membrane can include polymers containing heterocyclic nitrogen groups. In certain embodiments, a mass transport limiting membrane can include a polyvinylpyridine-based polymer. Non-limiting examples of polyvinylpyridine-based polymers are disclosed in U.S. Patent Publication No. 2003/0042137 (*e.g.*, Formula 2b), the contents of which are incorporated by reference herein in its entirety.

25  
30 [0315] In certain embodiments, a mass transport limiting membrane can include a polyvinylpyridine (*e.g.*, poly(4-vinylpyridine) or poly(4-vinylpyridine)), a polyvinylimidazole, a polyvinylpyridine copolymer (*e.g.*, a copolymer of vinylpyridine and styrene), a polyacrylate, a polyurethane, a polyether urethane, homopolymers, copolymers or terpolymers of polyurethanes, a silicone, a polytetrafluoroethylene, a polyethylene-co-tetrafluoroethylene, a polyolefin, a polyester, a polycarbonate, a biostable polytetrafluoroethylene, a polypropylene, a polyvinylchloride, a polyvinylidene

difluoride, a polybutylene terephthalate, a polymethylmethacrylate, a polyether ether ketone, cellulosic polymers, polysulfones and block copolymers thereof including, for example, di-block, tri-block, alternating, random and graft copolymers or a chemically related material and the like.

5 [0316] In certain embodiments, a membrane for use in the present disclosure, *e.g.*, a single-component membrane, can include a polyvinylpyridine (*e.g.*, poly(4-vinylpyridine) and/or poly(2-vinylpyridine)). In certain embodiments, a membrane for use in the present disclosure, *e.g.*, a single-component membrane, can include poly(4-vinylpyridine). In certain embodiments, a membrane for use in the present disclosure, *e.g.*, a single-  
10 component membrane, can include a copolymer of vinylpyridine and styrene. In certain embodiments, the membrane can comprise a polyvinylpyridine-co-styrene copolymer. For example, but not by way of limitation, a polyvinylpyridine-co-styrene copolymer for use in the present disclosure can include a polyvinylpyridine-co-styrene copolymer in which a portion of the pyridine nitrogen atoms were functionalized with a non-crosslinked  
15 polyethylene glycol tail and a portion of the pyridine nitrogen atoms were functionalized with an alkylsulfonic acid, *e.g.*, a propylsulfonic acid, group. In certain embodiments, a derivatized polyvinylpyridine-co-styrene copolymer for use as a membrane polymer can be the 10Q5 polymer as described in U.S. Patent No. 8,761,857, the contents of which are incorporated by reference herein in its entirety. In certain embodiments, the  
20 polyvinylpyridine-based polymer has a molecular weight from about 50 Da to about 500 kDa.

[0317] A suitable copolymer of vinylpyridine and styrene can have a styrene content ranging from about 0.01% to about 50% mole percent, or from about 0.05% to about 45% mole percent, or from about 0.1% to about 40% mole percent, or from about 0.5% to about  
25 35% mole percent, or from about 1% to about 30% mole percent, or from about 2% to about 25% mole percent, or from about 5% to about 20% mole percent. Substituted styrenes can be used similarly and in similar amounts. A suitable copolymer of vinylpyridine and styrene can have a molecular weight of 5 kDa or more, or about 10 kDa or more, or about 15 kDa or more, or about 20 kDa or more, or about 25 kDa or more, or  
30 about 30 kDa or more, or about 40 kDa or more, or about 50 kDa or more, or about 75 kDa or more, or about 90 kDa or more, or about 100 kDa or more. In non-limiting examples, a suitable copolymer of vinylpyridine and styrene can have a molecular weight ranging from about 5 kDa to about 150 kDa, or from about 10 kDa to about 125 kDa, or from about



15 kDa to about 100 kDa, or from about 20 kDa to about 80 kDa, or from about 25 kDa to about 75 kDa, or from about 30 kDa to about 60 kDa.

[0318] In certain embodiments, the membrane can comprise polymers such as, but not limited to, poly(styrene co-maleic anhydride), dodecylamine and poly(propylene glycol)-  
5 block-polyethylene glycol)-block-poly(propylene glycol) (2-aminopropyl ether) crosslinked with poly(propylene glycol)-block-poly(ethylene glycol)-block-poly(propylene glycol) bis(2-aminopropyl ether); poly(N-isopropyl acrylamide); a copolymer of poly(ethylene oxide) and poly(propylene oxide); or a combination thereof.

[0319] In certain embodiments, the membrane includes a polyurethane membrane that  
10 includes both hydrophilic and hydrophobic regions. In certain embodiments, a hydrophobic polymer component is a polyurethane, a polyurethane urea or poly(ether-urethane-urea). In certain embodiments, a polyurethane is a polymer produced by the condensation reaction of a diisocyanate and a difunctional hydroxyl-containing material. In certain embodiments, a polyurethane urea is a polymer produced by the  
15 reaction of a diisocyanate and a difunctional amine-containing material. In certain embodiments, diisocyanates for use herein include aliphatic diisocyanates, *e.g.*, containing from about 4 to about 8 methylene units, or diisocyanates containing cycloaliphatic moieties. Additional non-limiting examples of polymers that can be used for the generation of a membrane of a presently disclosed sensor include vinyl polymers, polyethers,  
20 polyesters, polyamides, inorganic polymers (*e.g.*, polysiloxanes and polycarbosiloxanes), natural polymers (*e.g.*, cellulosic and protein based materials) and mixtures (*e.g.*, admixtures or layered structures) or combinations thereof. In certain embodiments, the hydrophilic polymer component is polyethylene oxide and/or polyethylene glycol. In certain embodiments, the hydrophilic polymer component is a polyurethane copolymer.  
25 For example, but not by way of limitation, a hydrophobic-hydrophilic copolymer component for use in the present disclosure is a polyurethane polymer that comprises about 10% to about 50%, *e.g.*, 20%, hydrophilic polyethylene oxide.

[0320] In certain embodiments, the membrane includes a silicone polymer/hydrophobic-hydrophilic polymer blend. In certain embodiments, the hydrophobic-hydrophilic  
30 polymer for use in the blend can be any suitable hydrophobic-hydrophilic polymer such as, but not limited to, polyvinylpyrrolidone, polyhydroxyethyl methacrylate, polyvinylalcohol, polyacrylic acid, polyethers such as polyethylene glycol or polypropylene oxide, and copolymers thereof, including, for example, di-block, tri-block, alternating, random, comb, star, dendritic and graft copolymers. In certain embodiments,

the hydrophobic-hydrophilic polymer is a copolymer of poly(ethylene oxide) (PEO) and poly(propylene oxide) (PPO). Non-limiting examples of PEO and PPO copolymers include PEO-PPO diblock copolymers, PPO-PEO-PPO triblock copolymers, PEO-PPO-PEO triblock copolymers, alternating block copolymers of PEO-PPO, random copolymers of ethylene oxide and propylene oxide and blends thereof. In certain embodiments, the copolymers can be substituted with hydroxy substituents.

[0321] In certain embodiments, hydrophilic or hydrophobic modifiers can be used to “fine-tune” the permeability of the resulting membrane to an analyte of interest. In certain embodiments, hydrophilic modifiers such as poly(ethylene) glycol, hydroxyl or polyhydroxyl modifiers and the like, and any combinations thereof, can be used to enhance the biocompatibility of the polymer or the resulting membrane.

[0322] In certain embodiments where multiple active areas are present, the mass transport limiting membrane can overcoat each active area, including the option of compositional variation upon differing active areas, which can be achieved through sequential dip coating operations to produce a bilayer membrane portion upon a working electrode located closer to the sensor tip.

[0323] In certain embodiments where multiple active areas are present, a separate mass transport limiting membrane can overcoat each active area. For example, but not by way of limitation, a mass transport limiting membrane can be disposed on the first active area, e.g., the aspartate-responsive active area or asparagine-responsive active area, and a separate, second mass transport limiting membrane can overcoat the second active area. In certain embodiments, the two mass transport limiting membranes are spatially separated and do not overlap each other. In certain embodiments, the first mass transport limiting membrane does not overlap the second mass transport limiting membrane and the second mass transport limiting membrane does not overlap the first mass transport limiting membrane. Alternatively, the second mass transport limiting membrane overlaps the first mass transport limiting membrane. In certain embodiments, the first mass transport limiting membrane comprises different polymers than the second mass transport limiting membrane. Alternatively, the first mass transport limiting membrane comprises the same polymers as the second mass transport limiting membrane. In certain embodiments, the first mass transport limiting membrane comprises the same polymers as the second mass transport limiting membrane but comprise different crosslinking agents.

[0324] In certain embodiments of the present disclosure, an asparagine-responsive active area used for indirect measurement of potassium ions can be overcoated with a multi-

component membrane including a polyvinylpyridine and a polyvinylpyridine-co-styrene copolymer, either as a bilayer membrane or a homogeneous admixture, and a second analyte-responsive active area can be overcoated with a single-component membrane that includes polyvinylpyridine or a polyvinylpyridine-co-styrene copolymer. Alternatively, an asparagine-responsive active area used for indirect measurement of potassium ions can be overcoated with a single-component membrane that includes polyvinylpyridine or a polyvinylpyridine-co-styrene copolymer and a second analyte-responsive active area can be overcoated with a multi-component membrane including a polyvinylpyridine and a polyvinylpyridine-co-styrene copolymer, either as a bilayer membrane or a homogeneous admixture.

[0325] In certain embodiments of the present disclosure, an aspartate-responsive active area used for indirect measurement of potassium ions can be overcoated with a multi-component membrane including a polyvinylpyridine and a polyvinylpyridine-co-styrene copolymer, either as a bilayer membrane or a homogeneous admixture, and a second analyte-responsive active area can be overcoated with a single-component membrane that includes polyvinylpyridine or a polyvinylpyridine-co-styrene copolymer. Alternatively, an aspartate-responsive active area used for indirect measurement of potassium ions can be overcoated with a single-component membrane that includes polyvinylpyridine or a polyvinylpyridine-co-styrene copolymer and a second analyte-responsive active area can be overcoated with a multi-component membrane including a polyvinylpyridine and a polyvinylpyridine-co-styrene copolymer, either as a bilayer membrane or a homogeneous admixture.

[0326] Polydimethylsiloxane (PDMS) can be incorporated in any of the mass transport limiting membranes disclosed herein.

[0327] In certain embodiments, the mass transport limiting membrane can comprise a membrane polymer crosslinked with a crosslinking agent disclosed herein and above in Section 4. In certain embodiments where there are two mass transport limiting membranes, *e.g.*, a first mass transport limiting membrane and a second mass transport limiting membrane, each membrane can be crosslinked with a different crosslinking agent. For example, but not by way of limitation, the crosslinking agent can result in a membrane that is more restrictive to diffusion of certain compounds, *e.g.*, analytes within the membrane, or less restrictive to diffusion of certain compounds, *e.g.*, by affecting the size of the pores within the membrane. For example, but not by way of limitation, in a sensor that is configured to detect potassium, the mass transport limiting membrane overcoating

the analyte-responsive area can have a pore size that restricts the diffusion of compounds larger than potassium through the membrane.

[0328] In certain embodiments, crosslinking agents for use in the present disclosure can include polyepoxides, carbodiimide, cyanuric chloride, triglycidyl glycerol, N-hydroxysuccinimide, imidoesters, epichlorohydrin or derivatized variants thereof. In certain embodiments, a membrane polymer overcoating one or more active areas can be crosslinked with a branched crosslinker, *e.g.*, which can decrease the amount of extractables obtainable from the mass transport limiting membrane. Non-limiting examples of a branched crosslinker include branched glycidyl ether crosslinkers, *e.g.*, including branched glycidyl ether crosslinkers that include two or three or more crosslinkable groups. In certain embodiments, the branched crosslinker can include two or more crosslinkable groups, such as polyethylene glycol diglycidyl ether. In certain embodiments, the branched crosslinker can include three or more crosslinkable groups, such as polyethylene glycol tetraglycidyl ether. In certain embodiments, the mass transport limiting membrane can include polyvinylpyridine or a copolymer of vinylpyridine and styrene crosslinked with a branched glycidyl ether crosslinker including two or three crosslinkable groups, such as polyethylene glycol tetraglycidyl ether or polyethylene glycol diglycidyl ether. In certain embodiments, the epoxide groups of a polyepoxides, *e.g.*, polyethylene glycol tetraglycidyl ether or polyethylene glycol diglycidyl ether, can form a covalent bond with pyridine or an imidazole via epoxide ring opening resulting in a hydroxyalkyl group bridging a body of the crosslinker to the heterocycle of the membrane polymer.

[0329] In certain embodiments, the crosslinking agent is polyethylene glycol diglycidyl ether (PEGDGE). In certain embodiments, the PEGDGE used to promote crosslinking (*e.g.*, intermolecular crosslinking) between two or more membrane polymer backbones can exhibit a broad range of suitable molecular weights. In certain embodiments, the molecular weight of the PEGDGE can range from about 100 g/mol to about 5,000 g/mol. The number of ethylene glycol repeat units in each arm of the PEGDGE can be the same or different, and can typically vary over a range within a given sample to afford an average molecular weight. In certain embodiments, the PEGDGE for use in the present disclosure has an average molecular weight ( $M_n$ ) from about 200 to 1,000, *e.g.*, about 400. In certain embodiments, the crosslinking agent is PEGDGE 400.

[0330] In certain embodiments, the polyethylene glycol tetraglycidyl ether used to promote crosslinking (*e.g.*, intermolecular crosslinking) between two or more membrane

polymer backbones can exhibit a broad range of suitable molecular weights. Up to four polymer backbones may crosslinked with a single molecule of the polyethylene glycol tetraglycidyl ether crosslinker. In certain embodiments, the molecular weight of the polyethylene glycol tetraglycidyl ether can range from about 1,000 g/mol to about 5,000 g/mol. The number of ethylene glycol repeat units in each arm of the polyethylene glycol tetraglycidyl ether can be the same or different, and can typically vary over a range within a given sample to afford an average molecular weight. In certain embodiments, the mass transport limiting membrane can be deposited directly onto the active area.

[0331] In certain other embodiments, a membrane polymer overcoating one or more active areas can be crosslinked with a branched crosslinker including three or more crosslinkable groups, such as polyethylene glycol tetraglycidyl ether, which can decrease the amount of extractables obtainable from the mass transport limiting membrane, as referenced above. In certain embodiments, the mass transport limiting membrane can include polyvinylpyridine or a copolymer of vinylpyridine and styrene crosslinked with a branched glycidyl ether crosslinker including three crosslinkable groups, such as polyethylene glycol tetraglycidyl ether. In certain embodiments, the epoxide groups of the polyethylene glycol tetraglycidyl ether can form a covalent bond with pyridine or an imidazole via epoxide ring opening resulting in a hydroxyalkyl group bridging a body of the crosslinker to the heterocycle of the membrane polymer.

[0332] In certain embodiments, an analyte sensor described herein for monitoring potassium, *e.g.*, potassium ion, levels can include a sensor tail including at least one working electrode, an asparagine-responsive active area disposed upon a surface of the working electrode and a mass transport limiting membrane permeable to asparagine and potassium that overcoats at least the first active area. In certain embodiments, the asparagine-responsive active area includes an asparaginase, an aspartate oxidase, an electron transfer agent and, optionally, a polymer. In certain embodiments, one or both enzymes are covalently bonded to the polymer.

[0333] In certain embodiments, an analyte sensor of the present disclosure for monitoring potassium, *e.g.*, potassium ion, levels can include a sensor tail including at least two or more working electrodes, *e.g.*, a first working electrode and a second working electrode. In certain embodiments, a first asparagine-responsive active area comprising an asparaginase, an aspartate oxidase and an electron transfer agent is disposed upon a surface of the first working electrode. In certain embodiments, a second asparagine-responsive active area comprising an asparaginase, an aspartate oxidase and an electron transfer agent

is disposed upon a surface of the second working electrode. In certain embodiments, the analyte sensor further includes a mass transport limiting membrane permeable to asparagine and/or potassium that overcoats at least one of the asparagine-responsive active area. In certain embodiments, the mass transport limiting membrane permeable to asparagine and/or potassium overcoats both of the asparagine-responsive active areas. Alternatively, a first mass transport limiting membrane permeable to asparaginase overcoats the first asparagine-responsive active area and a second mass transport limiting membrane permeable to asparaginase overcoats the second asparagine-responsive active area. In certain embodiments, the first mass transport limiting membrane and the second mass transport limiting membrane comprise the same polymers. Alternatively, the first mass transport limiting membrane and the second mass transport limiting membrane comprise different polymers.

[0334] In certain embodiments, an analyte sensor described herein for monitoring potassium, *e.g.*, potassium ion, levels can include a sensor tail including at least one working electrode, an aspartate-responsive active area disposed upon a surface of the working electrode and a mass transport limiting membrane permeable to aspartate and potassium that overcoats at least the first active area. In certain embodiments, the aspartate-responsive active area includes an aspartate oxidase, an electron transfer agent and, optionally, a polymer. In certain embodiments, the enzyme is covalently bonded to the polymer.

[0335] In certain embodiments, an analyte sensor of the present disclosure for monitoring potassium, *e.g.*, potassium ion, levels can include a sensor tail comprising at least two or more working electrodes, *e.g.*, a first working electrode and a second working electrode, where each working electrode has an aspartate-responsive active area. For example, but not by way of limitation, a first aspartate-responsive active area comprising an aspartate oxidase and an electron transfer agent is disposed upon a surface of the first working electrode. In certain embodiments, a second aspartate-responsive active area comprising an aspartate oxidase and an electron transfer agent is disposed upon a surface of the second working electrode. In certain embodiments, the analyte sensor further includes a mass transport limiting membrane permeable to aspartate and/or potassium that overcoats at least one of the aspartate-responsive active area. In certain embodiments, the mass transport limiting membrane permeable to aspartate and/or potassium overcoats both of the aspartate-responsive active areas. Alternatively, a first mass transport limiting membrane permeable to aspartate and/or potassium overcoats the first aspartate-

responsive active area and a second mass transport limiting membrane permeable to aspartate and/or potassium overcoats the second aspartate-responsive active area. In certain embodiments, the first mass transport limiting membrane and the second mass transport limiting membrane comprise the same polymers. Alternatively, the first mass transport limiting membrane and the second mass transport limiting membrane comprise different polymers.

[0336] In certain embodiments, an analyte sensor of the present disclosure for monitoring potassium, *e.g.*, potassium ion, levels can include a sensor tail including at least three or more working electrodes, *e.g.*, a first working electrode, a second working electrode and a third working electrode, where the two of the three working electrodes are configured to detect different analytes. In certain embodiments, a first aspartate-responsive active area comprising a potassium-dependent aspartate oxidase and an electron transfer agent is disposed upon a surface of the first working electrode. In certain embodiments, a second aspartate-responsive active area comprising a potassium-independent aspartate oxidase and an electron transfer agent is disposed upon a surface of the second working electrode. In certain embodiments, an additional analyte-responsive active area comprising an enzyme for detecting a second analyte is disposed upon a surface of the third working electrode. In certain embodiments, the analyte sensor further includes a mass transport limiting membrane permeable to aspartate and/or potassium that overcoats at least one, *e.g.*, both, of the aspartate-responsive active areas. In certain embodiments, the mass transport limiting membrane permeable to aspartate and/or potassium overcoats one or more aspartate-responsive active areas and the second-analyte responsive active area. Alternatively, a first mass transport limiting membrane permeable to aspartate and/or potassium overcoats at least one, *e.g.*, both, of the aspartate-responsive active areas and a second mass transport limiting membrane permeable to the second analyte overcoats the second-analyte responsive active area. In certain embodiments, the second mass transport limiting membrane permeable to the second analyte overcoats at least a portion of at least one, or both, of the aspartate-responsive active areas.

[0337] In certain embodiments, an analyte sensor of the present disclosure for monitoring potassium, *e.g.*, potassium ion, levels can include a sensor tail including at least three or more working electrodes, *e.g.*, a first working electrode, a second working electrode and a third working electrode, where the two of the three working electrodes are configured to detect different analytes. In certain embodiments, a first asparagine-responsive active area comprising an aspartate oxidase, potassium-dependent asparaginase and an electron

transfer agent is disposed upon a surface of the first working electrode. In certain embodiments, a second asparagine-responsive active area comprising an aspartate oxidase, a potassium-independent asparaginase and an electron transfer agent is disposed upon a surface of the second working electrode. In certain embodiments, an additional analyte-responsive active area comprising an enzyme for detecting a second analyte is disposed upon a surface of the third working electrode. In certain embodiments, the analyte sensor further includes a mass transport limiting membrane permeable to asparagine and/or potassium that overcoats at least one, *e.g.*, both, of the asparagine-responsive active areas. In certain embodiments, the mass transport limiting membrane permeable to asparagine and/or potassium overcoats one or more asparagine-responsive active areas and the second-analyte responsive active area. Alternatively, a first mass transport limiting membrane permeable to asparagine and/or potassium overcoats at least one, *e.g.*, both, of the asparagine-responsive active areas and a second mass transport limiting membrane permeable to the second analyte overcoats the second-analyte responsive active area. In certain embodiments, the second mass transport limiting membrane permeable to the second analyte overcoats at least a portion of at least one, or both, of asparagine-responsive active areas.

[0338] In certain embodiments, the mass transport limiting membrane has a thickness, *e.g.*, dry thickness, ranging from about 0.1  $\mu\text{m}$  to about 1,000  $\mu\text{m}$ , *e.g.*, from about 1  $\mu\text{m}$  to about 500  $\mu\text{m}$ , about 10  $\mu\text{m}$  to about 100  $\mu\text{m}$  or about 10  $\mu\text{m}$  to about 100  $\mu\text{m}$ . In certain embodiments, the mass transport limiting membrane can have a thickness from about 0.1  $\mu\text{m}$  to about 100  $\mu\text{m}$ , *e.g.*, from about 1  $\mu\text{m}$  to about 90  $\mu\text{m}$ , from about 1  $\mu\text{m}$  to about 80  $\mu\text{m}$ , from about 1  $\mu\text{m}$  to about 70  $\mu\text{m}$ , from about 1  $\mu\text{m}$  to about 60  $\mu\text{m}$ , from about 1  $\mu\text{m}$  to about 50  $\mu\text{m}$ , from about 1  $\mu\text{m}$  to about 40  $\mu\text{m}$ , from about 1  $\mu\text{m}$  to about 30  $\mu\text{m}$ , from about 1  $\mu\text{m}$  to about 20  $\mu\text{m}$ , from about 0.5  $\mu\text{m}$  to about 10  $\mu\text{m}$ , from about 1  $\mu\text{m}$  to about 10  $\mu\text{m}$ , from about 1  $\mu\text{m}$  to about 5  $\mu\text{m}$  or from about 0.1  $\mu\text{m}$  to about 5  $\mu\text{m}$ . In certain embodiments, the mass transport limiting membrane can have a thickness from about 1  $\mu\text{m}$  to about 100  $\mu\text{m}$ . In certain embodiments, the sensor can be dipped in the mass transport limiting membrane solution more than once. For example, but not by way of limitation, a sensor (or working electrode) of the present disclosure can be dipped in a mass transport limiting membrane solution at least twice, at least three times, at least four times or at least five times to obtain the desired mass transport limiting membrane thickness.



## 6. Interference Domain

[0339] In certain embodiments, the sensor of the present disclosure, *e.g.*, sensor tail, can further comprise an interference domain. In certain embodiments, the interference domain can include a polymer domain that restricts the flow of one or more interferants, *e.g.*, to the surface of the working electrode. In certain embodiments, the interference domain can function as a molecular sieve that allows analytes and other substances that are to be measured by the working electrode to pass through, while preventing passage of other substances such as interferents. In certain embodiments, the interferents can affect the signal obtained at the working electrode. Non-limiting examples of interferents include acetaminophen, ascorbate, ascorbic acid, bilirubin, cholesterol, creatinine, dopamine, ephedrine, ibuprofen, L-dopa, methyl dopa, salicylate, tetracycline, tolazamide, tolbutamide, triglycerides, urea and uric acid.

[0340] In certain embodiments, the interference domain is located between the working electrode and one or more active areas, *e.g.*, asparagine-responsive active area or aspartate-responsive active area. In certain embodiments, non-limiting examples of polymers that can be used in the interference domain include polyurethanes, polymers having pendant ionic groups and polymers having controlled pore size. In certain embodiments, the interference domain is formed from one or more cellulosic derivatives. Non-limiting examples of cellulosic derivatives include polymers such as cellulose acetate, cellulose acetate butyrate, 2-hydroxyethyl cellulose, cellulose acetate phthalate, cellulose acetate propionate, cellulose acetate trimellitate and the like.

[0341] In certain embodiments, the interference domain is part of the mass transport limiting membrane and not a separate membrane. In certain embodiments, the interference domain is disposed between the mass limiting membrane and one or more analyte-responsive active areas.

[0342] In certain embodiments, the interference domain includes a thin, hydrophobic membrane that is non-swellaable and restricts diffusion of high molecular weight species. For example, but not by way of limitation, the interference domain can be permeable to relatively low molecular weight substances while restricting the passage of higher molecular weight substances.

[0343] In certain embodiments, the interference domain can be deposited directly onto the working electrode, *e.g.*, onto the surface of the permeable working electrode. In certain embodiments, the interference domain has a thickness, *e.g.*, dry thickness, ranging from about 0.1  $\mu\text{m}$  to about 1,000  $\mu\text{m}$ , *e.g.*, from about 1  $\mu\text{m}$  to about 500  $\mu\text{m}$ , about 10  $\mu\text{m}$  to

about 100  $\mu\text{m}$  or about 10  $\mu\text{m}$  to about 100  $\mu\text{m}$ . In certain embodiments, the interference domain can have a thickness from about 0.1  $\mu\text{m}$  to about 100  $\mu\text{m}$ , *e.g.*, from about 1  $\mu\text{m}$  to about 90  $\mu\text{m}$ , from about 1  $\mu\text{m}$  to about 80  $\mu\text{m}$ , from about 1  $\mu\text{m}$  to about 70  $\mu\text{m}$ , from about 1  $\mu\text{m}$  to about 60  $\mu\text{m}$ , from about 1  $\mu\text{m}$  to about 50  $\mu\text{m}$ , from about 1  $\mu\text{m}$  to about 40  $\mu\text{m}$ , from about 1  $\mu\text{m}$  to about 30  $\mu\text{m}$ , from about 1  $\mu\text{m}$  to about 20  $\mu\text{m}$ , from about 0.5  $\mu\text{m}$  to about 10  $\mu\text{m}$ , from about 1  $\mu\text{m}$  to about 10  $\mu\text{m}$ , from about 1  $\mu\text{m}$  to about 5  $\mu\text{m}$  or from about 0.1  $\mu\text{m}$  to about 5  $\mu\text{m}$ . In certain embodiments, the sensor can be dipped in the interference domain solution more than once. For example, but not by way of limitation, a sensor (or working electrode) of the present disclosure can be dipped in an interference domain solution at least twice, at least three times, at least four times or at least five times to obtain the desired interference domain thickness.

### 7. *Manufacturing*

[0344] The present disclosure further provides methods for manufacturing the presently disclosed analyte sensors that includes one or more active sites. In certain embodiments, the method includes screen printing a working electrode, *e.g.*, a carbon working electrode, *e.g.*, by using a carbon ink.

[0345] In certain embodiments, the method can further include adding a composition including an enzyme onto a surface of the working electrode to generate an analyte-responsive active area on the working electrode. For example, but not by way of limitation, the composition can include an aspartate oxidase, *e.g.*, a potassium-dependent aspartate oxidase or a potassium-independent aspartate oxidase. In certain embodiments, the composition can further include an asparaginase, *e.g.*, a potassium-dependent asparaginase or a potassium-independent asparaginase. In certain embodiments, the composition can further include a redox mediator. In certain embodiments, the composition can further include a crosslinking agent, *e.g.*, polyethylene glycol diglycidyl ether, and a stabilizing agent, *e.g.*, an albumin such as BSA. In certain embodiments, the method can further include curing the enzyme composition.

[0346] Alternatively, a first enzyme composition including an aspartate oxidase can be initially deposited onto a surface of the working electrode to generate an analyte-responsive active area on the working electrode. In certain embodiments, the first enzyme composition can further include a redox mediator, a crosslinking agent, *e.g.*, polyethylene glycol diglycidyl ether, and/or a stabilizing agent, *e.g.*, an albumin such as BSA. In certain embodiments, the method can include curing the first enzyme composition to generate a first enzyme layer. In certain embodiments, the method can include depositing a second

enzyme composition including an asparaginase onto a surface of the first enzyme layer, and curing the second enzyme composition to generate a first second layer. In certain embodiments, the second enzyme composition can include, a crosslinking agent, *e.g.*, polyethylene glycol diglycidyl ether, and/or a stabilizing agent, *e.g.*, an albumin such as BSA.

5 [0347] In analyte sensors with two working electrodes, a second analyte-responsive active area can be generated on a second working electrode using the methods described herein. In certain embodiments, in analyte sensors with two working electrodes, a second aspartate-responsive active area or a second asparagine-responsive active area can be generated on a second working electrode using the methods described herein. In certain  
10 embodiments, the first aspartate-responsive active area comprises a potassium-independent aspartate oxidase and the second aspartate-responsive active area comprises a potassium-dependent aspartate oxidase. In certain embodiments, the first asparagine-responsive active area comprises a potassium-independent asparaginase and the second  
15 asparagine-responsive active area comprises a potassium-dependent asparaginase.

[0348] In analyte sensors with three working electrodes, an active area responsive to a second analyte can be generated on a third working electrode using the methods described herein. Non-limiting examples of second analytes can be glucose, ketones, lactate, oxygen, hemoglobin A1C, albumin, alcohol, alkaline phosphatase, alanine transaminase,  
20 aspartate aminotransferase, bilirubin, blood urea nitrogen, calcium, carbon dioxide, chloride, creatinine, hematocrit, lactate, magnesium, oxygen, pH, phosphorus, potassium, sodium, aspartate, asparagine, total protein, uric acid, hormones, *e.g.*, cortisol, etc.

[0349] In certain embodiments, the method can further include adding a membrane composition on top of the cured enzyme composition(s). In certain embodiments, the  
25 membrane composition can include a polymer, *e.g.*, polyvinylpyridine-based polymer, *e.g.*, a polyvinylpyridine, and/or a crosslinking agent, *e.g.*, polyethylene glycol diglycidyl ether. In certain embodiments, the method can include curing the polymer composition.

[0350] Generally, the thickness of the membrane is controlled by the concentration of the membrane solution, by the number of droplets of the membrane solution applied, by the  
30 number of times the sensor is dipped in or sprayed with the membrane solution, by the volume of membrane solution sprayed on the sensor, and the like, and by any combination of these factors. In certain embodiments, the membrane described herein can have a thickness ranging from about 0.1 micrometers ( $\mu\text{m}$ ) to about 1,000  $\mu\text{m}$ , *e.g.*, from about 1  $\mu\text{m}$  to and about 500  $\mu\text{m}$ , about 10  $\mu\text{m}$  to about 100  $\mu\text{m}$  or about 10  $\mu\text{m}$  to about 100  $\mu\text{m}$ .

In certain embodiments, the sensor can be dipped in the membrane solution more than once. For example, but not by way of limitation, a sensor (or working electrode) of the present disclosure can be dipped in a membrane solution at least twice, at least three times, at least four times or at least five times to obtain the desired membrane thickness.

- 5 [0351] In certain embodiments, the membrane can overlay one or more active areas, and in certain embodiments, the active areas can have a thickness from about 0.1  $\mu\text{m}$  to about 100  $\mu\text{m}$ , *e.g.*, from about 1  $\mu\text{m}$  to about 90  $\mu\text{m}$ , from about 1  $\mu\text{m}$  to about 80  $\mu\text{m}$ , from about 1  $\mu\text{m}$  to about 70  $\mu\text{m}$ , from about 1  $\mu\text{m}$  to about 60  $\mu\text{m}$ , from about 1  $\mu\text{m}$  to about 50  $\mu\text{m}$ , from about 1  $\mu\text{m}$  to about 40  $\mu\text{m}$ , from about 1  $\mu\text{m}$  to about 30  $\mu\text{m}$ , from about 1  $\mu\text{m}$  to about 20  $\mu\text{m}$ , from about 0.5  $\mu\text{m}$  to about 10  $\mu\text{m}$ , from about 1  $\mu\text{m}$  to about 10  $\mu\text{m}$ , from about 1  $\mu\text{m}$  to about 5  $\mu\text{m}$  or from about 0.1  $\mu\text{m}$  to about 5  $\mu\text{m}$ . In certain embodiments, a series of droplets can be applied atop of one another to achieve the desired thickness of the active area and/or membrane, without substantially increasing the diameter of the applied droplets (*i.e.*, maintaining the desired diameter or range thereof).
- 10
- 15 In certain embodiments, each single droplet can be applied and then allowed to cool or dry, followed by one or more additional droplets. For example, but not by way of limitation, at least one droplet, at least two droplets, at least three droplets, at least four droplets or at least five droplets are added atop of one another to achieve the desired thickness of the active area.

20

### III. METHODS OF USE

- [0352] The present disclosure further provides methods of using the analyte sensors disclosed herein. In certain embodiments, the present disclosure provides methods for monitoring potassium, *e.g.*, potassium ion, levels in a sample. For example, but not by way of limitation, the subject in need of potassium monitoring can be a subject that is a risk of developing or has developed one or more disorders and/or conditions associated with dysregulated levels of potassium as described herein. In certain embodiments, the subject in need of potassium monitoring can be a subject that is at risk of developing or has developed one or more disorders and/or conditions associated with a potassium deficiency as described herein. In certain embodiments, the subject in need of potassium monitoring can be a subject that is at risk of developing or has developed one or more disorders and/or conditions associated with elevated levels of potassium as described herein.
- 25
- 30

[0353] In certain embodiments, a potassium sensor of the present disclosure can be used to continuously monitor potassium levels in a subject at risk of having or has a neurological disorder, *e.g.*, Parkinson's disease, Alzheimer's disease, Huntington's disease, amyotrophic lateral sclerosis or Lou Gehrig's disease (ALS) and multiple sclerosis (MS).

5 Additional examples of diseases and disorders associated with potassium dysregulation include autism, cancer, heart failure, myocardial infarction and atherosclerosis as disclosed in Udensi and Tchounwou, *Int. J. Clin. Exp. Physiol.* 4(3):111-122 (2017), the contents of which is hereby incorporated by reference in its entirety.

[0354] In certain embodiments, a potassium sensor of the present disclosure can be  
10 implanted in a subject at risk of developing or has developed one or more disorders and/or conditions associated with a potassium deficiency. In certain embodiments, a potassium sensor of the present disclosure can be implanted in a subject for up to about 10 days, about 11 days, about 12 days, about 13 days, about 14 days, about 15 days, about 16 days, about 17 days, about 18 days, about 19 days or about 20 days. In certain embodiments, the  
15 potassium sensors of the present disclosure can be implanted in a subject for up to about 15 days.

[0355] In certain embodiments, a method for monitoring potassium includes: (i) providing an analyte sensor including: (a) a sensor tail including at least a first working electrode and a second electrode; (b) a first asparagine-responsive active area disposed upon a  
20 surface of the first working electrode, where the asparagine-responsive active area includes an enzyme system including an aspartate oxidase and a first asparaginase and, optionally, a first polymer; (c) a second asparagine-responsive active area disposed upon a surface of the second working electrode, where the asparagine-responsive active area includes an enzyme system including aspartate oxidase and a second asparaginase and, optionally, a  
25 second polymer and (d) a mass transport limiting membrane permeable to asparagine that overcoats the first and/or second asparagine-responsive active areas. In certain embodiments, the method further includes (ii) applying a potential to the first working electrode; (iii) obtaining a first signal at or above an oxidation-reduction potential of the first asparagine-responsive active area; (iv) applying a potential to the second working  
30 electrode; (v) obtaining a second signal at or above an oxidation-reduction potential of the second asparagine-responsive active area; and (vi) correlating the first signal and the second signal to the concentration of potassium, *e.g.*, potassium ions, in the fluid. In certain embodiments, the first and/or second asparagine-responsive active areas further include an electron-transfer agent. In certain embodiments, the asparaginase of the first

asparagine-responsive active area is potassium-dependent and the asparaginase of the second asparagine-responsive active area is potassium-independent. Alternatively, both asparaginases are potassium-dependent but exhibit different potassium dependencies.

[0356] In certain embodiments, methods of the present disclosure for monitoring potassium can include: (i) exposing an analyte sensor to a fluid including potassium ions and asparagine, wherein the analyte sensor includes: (a) a sensor tail including at least a first working electrode and a second working electrode; (b) a first asparagine-responsive active area disposed upon a surface of the first working electrode, where the first asparagine-responsive active area includes an enzyme system comprising an aspartate oxidase and an asparaginase and, optionally, a first polymer; (c) a second aspartate-responsive active area disposed upon a surface of the second working electrode, where the second asparagine-responsive active area includes an enzyme system comprising an aspartate oxidase and an asparaginase and, optionally, a second polymer; and (d) a mass transport limiting membrane permeable to asparagine and potassium ions that overcoats the first and/or second asparagine-responsive active areas. In certain embodiments, the method further includes (ii) applying a potential to the first working electrode and the second working electrode; (iii) obtaining a first signal at or above an oxidation-reduction potential of the first asparagine-responsive active area; (iv) obtaining a second signal at or above an oxidation-reduction potential of the second asparagine-responsive active area; and (v) correlating the first signal and the second signal to the concentration of potassium ions in the fluid. In certain embodiments, the first and/or second asparagine-responsive active areas further include an electron-transfer agent. In certain embodiments, the asparaginase of the first asparagine-responsive active area is potassium-dependent and the asparaginase of the second asparagine-responsive active area is potassium-independent. Alternatively, both asparaginases are potassium-dependent but exhibit different potassium dependencies.

[0357] In certain embodiments, a method for monitoring potassium includes: (i) providing an analyte sensor including: (a) a sensor tail including at least a first working electrode and a second electrode; (b) a first aspartate-responsive active area disposed upon a surface of the first working electrode, where the first aspartate-responsive active area includes a first aspartate oxidase (*e.g.*, a potassium-dependent aspartate oxidase) and, optionally, a first polymer; (c) a second aspartate-responsive active area disposed upon a surface of the second working electrode, where the second aspartate-responsive active area includes a second aspartate oxidase (*e.g.*, a potassium-independent aspartate oxidase) and, optionally,

a second polymer and (d) a mass transport limiting membrane permeable to aspartate that overcoats the first and/or second aspartate-responsive active areas. In certain embodiments, the method further includes (ii) applying a potential to the first working electrode; (iii) obtaining a first signal at or above an oxidation-reduction potential of the first aspartate-responsive active area; (iv) applying a potential to the second working electrode; (v) obtaining a second signal at or above an oxidation-reduction potential of the second aspartate-responsive active area; and (vi) correlating the first signal and the second signal to the concentration of potassium, *e.g.*, potassium ions, in the fluid. In certain embodiments, the first and/or second aspartate-responsive active areas further include an electron-transfer agent. In certain embodiments, the aspartate oxidase of the first aspartate-responsive active area is potassium-dependent, and the aspartate oxidase of the second aspartate-responsive active area is potassium-independent. Alternatively, both aspartate oxidases are potassium-dependent but exhibit different potassium dependencies. In certain embodiments, the membrane polymer comprises a polyvinylpyridine or a polyvinylimidazole. In certain embodiments, the membrane polymer comprises a copolymer of vinylpyridine and styrene. In certain embodiments, the mass transport limiting membrane of the analyte sensor comprises a membrane polymer crosslinked with a branched crosslinker comprising three or more crosslinkable groups. In certain embodiments, the branched crosslinker comprises polyethylene glycol tetraglycidyl ether.

[0358] In certain embodiments, methods of the present disclosure for monitoring potassium can include: (i) exposing an analyte sensor to a fluid including potassium ions and aspartate, wherein the analyte sensor includes: (a) a sensor tail including at least a first working electrode and a second working electrode; (b) a first aspartate-responsive active area disposed upon a surface of the first working electrode, where the first aspartate-responsive active area includes a first aspartate oxidase and, optionally, a first polymer; (c) a second aspartate-responsive active area disposed upon a surface of the second working electrode, where the second aspartate-responsive active area includes a second aspartate oxidase and, optionally, a second polymer; and (d) a mass transport limiting membrane permeable to aspartate and potassium ions that overcoats the first and/or second aspartate-responsive active areas. In certain embodiments, the method further includes (ii) applying a potential to the first working electrode and the second working electrode; (iii) obtaining a first signal at or above an oxidation-reduction potential of the first aspartate-responsive active area, *e.g.*, where the first signal being proportional to a concentration of aspartate in the fluid; (iv) obtaining a second signal at or above an oxidation-reduction

potential of the second aspartate-responsive active area, *e.g.*, where the second signal being proportional to a concentration of aspartate in the fluid; and (v) correlating the first signal and the second signal to the concentration of potassium ions in the fluid. In certain embodiments, the first and/or second aspartate-responsive active areas further include an electron-transfer agent. In certain embodiments, the aspartate oxidase of the first aspartate-responsive active area is potassium-dependent, and the aspartate oxidase of the second aspartate-responsive active area is potassium-independent. Alternatively, both aspartate oxidases are potassium-dependent but exhibit different potassium dependencies.

[0359] In certain embodiments, the present disclosure further provides methods for detecting potassium and a second analyte. For example, but not by way of limitation, the method of the present disclosure can further include detecting a second analyte by providing an analyte sensor that includes an active area and/or exposing an analyte sensor that includes an active area to a fluid, *e.g.*, bodily fluid, comprising aspartate, potassium and the second analyte. In certain embodiments, the analyte sensor for use in a method for detecting potassium and a second analyte can further include a third working electrode; and an active area disposed upon a surface of the third working electrode and responsive to the second analyte differing from the first analyte, where the third active area comprises at least one enzyme responsive to the second analyte and, optionally, a second polymer and/or an electron transfer agent; wherein a portion, *e.g.*, second portion, of the mass transport limiting membrane overcoats the active area. Alternatively, the active area can be covered by a second mass transport limiting membrane that is separate and/or different than the mass transport limiting membrane that overcoats at least one of the aspartate-responsive active areas. In certain embodiments, the second mass transport limiting membrane can overcoat a portion of at least one of the aspartate-responsive active areas.

25

#### **IV. EXEMPLARY EMBODIMENTS**

[0360] A. In certain non-limiting embodiments, the presently disclosed subject matter provides analyte sensors for detecting potassium levels comprising:

- (i) a sensor tail comprising at least a first working electrode; and
- (ii) a first analyte-responsive active area disposed upon a surface of the first working electrode comprising a first aspartate oxidase.

30

[0361] A1. The analyte sensor of A, further comprising a first mass transport limiting membrane permeable to potassium that overcoats the first analyte-responsive active area.

[0362] A2. The analyte sensor of A or A1, wherein the first aspartate oxidase is a



potassium-dependent aspartate oxidase.

[0363] A3. The analyte sensor of A or A1, wherein the first aspartate oxidase is a potassium-independent aspartate oxidase.

5 [0364] A4. The analyte sensor of any one of A-A3, wherein the first analyte-responsive active area further comprises a first asparaginase.

[0365] A5. The analyte sensor of A4, wherein the first asparaginase is a potassium-dependent aspartate oxidase.

[0366] A6. The analyte sensor of A4, wherein the first asparaginase is a potassium-independent aspartate oxidase.

10 [0367] A7. The analyte sensor of any one of A-A6, further comprising a second working electrode and a second analyte-responsive active area disposed upon a surface of the second working electrode, wherein the second analyte-responsive active area comprises a second aspartate oxidase.

15 [0368] A8. The analyte sensor of A7, wherein the second aspartate oxidase is a potassium-dependent aspartate oxidase.

[0369] A9. The analyte sensor of A7, wherein the second aspartate oxidase is a potassium-independent aspartate oxidase.

[0370] A10. The analyte sensor of any one of A7-A9, wherein the first aspartate oxidase and the second aspartate oxidase exhibit different potassium dependencies.

20 [0371] A11. The analyte sensor of any one of A7-A10, wherein the second analyte-responsive active area further comprises a second asparaginase.

[0372] A12. The analyte sensor of A11, wherein the first asparaginase is a potassium-dependent aspartate oxidase.

25 [0373] A13. The analyte sensor of A11, wherein the second asparaginase is a potassium-independent aspartate oxidase.

[0374] A14. The analyte sensor of any one of A11-A13, wherein the first asparaginase and the second asparaginase exhibit different potassium dependencies.

30 [0375] A15. The analyte sensor of any one of A-A14, wherein the first analyte-responsive active area and/or the second analyte-responsive active area further comprises an electron transfer agent.

[0376] A16. The analyte sensor of any one of A-A15, wherein the first analyte-responsive active area and/or the second analyte-responsive active area further comprises a stabilizing agent.

[0377] A17. The analyte sensor of A16, wherein the stabilizing agent is an albumin.

- [0378] A18. The analyte sensor of A17, wherein the albumin is bovine serum albumin.
- [0379] A19. The analyte sensor of any one of A-A17, wherein the first analyte-responsive active area and/or the second analyte-responsive active area further comprises a polymer.
- [0380] A20. The analyte sensor of A19, wherein (i) the first aspartate oxidase and/or first asparaginase is covalently bonded to the polymer and/or (ii) the second aspartate oxidase and/or second asparaginase is covalently bonded to the polymer.
- [0381] A21. The analyte sensor of any one of A19-A20, wherein the first and/or second electron transfer agent is covalently bonded to the polymer.
- [0382] A22. The analyte sensor of A15-A21, wherein the first and second electron transfer agent are the same.
- [0383] A23. The analyte sensor of any one of A-A22, wherein the first mass transport limiting membrane overcoats the second analyte-responsive active area.
- [0384] A24. The analyte sensor of any one of A-A23, wherein the first mass transport limiting membrane comprises a polyvinylpyridine-based polymer, a polyvinylimidazole, a polyacrylate, a polyurethane, a polyether urethane, a silicone or a combination thereof.
- [0385] A25. The analyte sensor of A24, wherein the first mass transport limiting membrane comprises a polyvinylpyridine-based polymer.
- [0386] A26. The analyte sensor of A24, wherein the first mass transport limiting membrane comprises a polyurethane.
- [0387] A27. The analyte sensor of A24, wherein the first mass transport limiting membrane comprises a silicone.
- [0388] A28. The analyte sensor of A24, wherein the first mass transport limiting membrane comprises polyvinylpyridine.
- [0389] A29. The analyte sensor of A24, wherein the first mass transport limiting membrane comprises a copolymer of viaylpyridine and styrene.
- [0390] A30. The analyte sensor of A-A29, further comprising a third working electrode and a third analyte-responsive active area disposed upon a surface of the third working electrode and responsive to a second analyte differing from potassium, wherein the third analyte-responsive active area comprises at least one enzyme responsive to the second analyte.
- [0391] A31. The analyte sensor of A30, wherein the second analyte is selected from the group consisting of glutamate, glucose, ketones, lactate, oxygen, hemoglobin A1C, albumin, alcohol, alkaline phosphatase, alanine transaminase, aspartate aminotransferase, bilirubin, blood urea nitrogen, calcium, carbon dioxide, chloride, creatinine, hematocrit,

lactate, magnesium, oxygen, pH, phosphorus, potassium, asparagine, aspartate, sodium, total protein, uric acid and a combination thereof.

[0392] B. In certain non-limiting embodiments, the presently disclosed subject matter provides for analyte sensors comprising:

- 5 (i) a sensor tail comprising at least a first working electrode and a second working electrode;
- (ii) a first aspartate-responsive active area disposed upon a surface of the first working electrode comprising a first aspartate oxidase; and
- (iii) a second aspartate-responsive active area disposed upon a surface of the  
10 second working electrode comprising a second aspartate oxidase.

[0393] B1. The analyte sensor of B, further comprising a first mass transport limiting membrane permeable to aspartate and potassium that overcoats the first aspartate-responsive active area and/or the second aspartate-responsive active area.

[0394] B2. The analyte sensor of B or B1, wherein the first aspartate oxidase is a  
15 potassium-dependent aspartate oxidase.

[0395] B3. The analyte sensor of any one of B-B2, wherein the second aspartate oxidase is a potassium-independent aspartate oxidase.

[0396] B4. The analyte sensor of B or B1, wherein the first aspartate oxidase and second aspartate oxidase are potassium-dependent aspartate oxidases.

20 [0397] B5. The analyte sensor of B4, wherein the first aspartate oxidase and the second asparaginase exhibit different potassium dependencies.

[0398] B6. The analyte sensor of any one of B-B5, wherein the first aspartate-responsive active area further comprises an electron transfer agent.

[0399] B7. The analyte sensor of any one of B-B6, wherein the first aspartate-responsive  
25 active area further comprises a stabilizing agent.

[0400] B8. The analyte sensor of B7, wherein the stabilizing agent is an albumin.

[0401] B9. The analyte sensor of B8, wherein the albumin is bovine serum albumin.

[0402] B10. The analyte sensor of any one of B-B9, wherein the second aspartate-responsive active area further comprises an electron transfer agent.

30 [0403] B11. The analyte sensor of any one of B-B10, wherein the second aspartate-responsive active area further comprises a stabilizing agent.

[0404] B12. The analyte sensor of B11, wherein the stabilizing agent is an albumin.

[0405] B13. The analyte sensor of B12, wherein the albumin is bovine serum albumin.

[0406] B14. The analyte sensor of any one of B-B13, wherein the first and/or second

aspartate-responsive active areas further comprise a polymer.

[0407] B15. The analyte sensor of B14, wherein the first aspartate oxidase is covalently bonded to the polymer and/or the second aspartate oxidase is covalently bonded to the polymer.

5 [0408] B16. The analyte sensor of B14 or B15, wherein the first and/or second electron transfer agent is covalently bonded to the polymer.

[0409] B17. The analyte sensor of any one of B10-B16, wherein the first and second electron transfer agent are the same.

10 [0410] B18. The analyte sensor of any one of B1-B17, wherein the first mass transport limiting membrane comprises a polyvinylpyridine-based polymer, a polyvinylimidazole, a polyacrylate, a polyurethane, a polyether urethane, a silicone or a combination thereof.

[0411] B19. The analyte sensor of B18, wherein the first mass transport limiting membrane comprises a polyvinylpyridine-based polymer.

15 [0412] B20. The analyte sensor of B18, wherein the first mass transport limiting membrane comprises a polyurethane.

[0413] B21. The analyte sensor of B18, wherein the first mass transport limiting membrane comprises a silicone.

[0414] B22. The analyte sensor of B18, wherein the first mass transport limiting membrane comprises polyvinylpyridine.

20 [0415] B23. The analyte sensor of B18, wherein the first mass transport limiting membrane comprises a copolymer of vinylpyridine and styrene.

[0416] B24. The analyte sensor of B-B23, further comprising:

(iv) a third working electrode; and

25 (v) a third active area disposed upon a surface of the third working electrode and responsive to a second analyte differing from potassium, wherein the third active area comprises at least one enzyme responsive to the second analyte.

[0417] B25. The analyte sensor of B24, further comprising a second portion of the mass transport limiting membrane that overcoats the third active area.

30 [0418] B26. The analyte sensor of B24, further comprising a second mass transport limiting membrane that overcoats the third active area.

[0419] B27. The analyte sensor of B26, wherein the second mass transport limiting membrane further overcoats the first aspartate-responsive active area and/or the second aspartate-responsive active area.

[0420] B28. The analyte sensor of B26 or B27, wherein the second mass transport limiting

membrane comprises a polymer that is not present in the first mass transport limiting membrane.

[0421] C. In certain non-limiting embodiments, the presently disclosed subject matter provides for analyte sensors comprising:

- 5 (i) a sensor tail comprising at least a first working electrode and a second working electrode;
- (ii) a first asparagine-responsive active area disposed upon a surface of the first working electrode comprising a first aspartate oxidase and a first asparaginase; and
- 10 (iii) a second asparagine-responsive active area disposed upon a surface of the second working electrode comprising a second aspartate oxidase and a second asparaginase.

[0422] C1. The analyte sensor of C, further comprising a first mass transport limiting membrane permeable to aspartate and potassium that overcoats the first asparagine-responsive active area and/or the second asparagine-responsive active area.

15 [0423] C2. The analyte sensor of C or C1, wherein the first asparaginase is a potassium-dependent asparaginase.

[0424] C3. The analyte sensor of any one of C-C2, wherein the second asparaginase is a potassium-independent asparaginase.

20 [0425] C4. The analyte sensor of C or C1, wherein the first asparaginase and second asparaginase are potassium-dependent asparaginases.

[0426] C5. The analyte sensor of C4, wherein the first asparaginase and the second asparaginase exhibit different potassium dependencies.

[0427] C6. The analyte sensor of any one of C-C5, wherein the first asparagine-responsive active area further comprises an electron transfer agent.

25 [0428] C7. The analyte sensor of any one of C-C6, wherein the first asparagine-responsive active area further comprises a stabilizing agent.

[0429] C8. The analyte sensor of C7, wherein the stabilizing agent is an albumin.

[0430] C9. The analyte sensor of C8, wherein the albumin is bovine serum albumin.

30 [0431] C10. The analyte sensor of any one of C-C9, wherein the second asparagine-responsive active area further comprises an electron transfer agent.

[0432] C11. The analyte sensor of any one of C-C10, wherein the second asparagine-responsive active area further comprises a stabilizing agent.

[0433] C12. The analyte sensor of C11, wherein the stabilizing agent is an albumin.

[0434] C13. The analyte sensor of C12, wherein the albumin is bovine serum albumin.

- [0435] C14. The analyte sensor of any one of C-C13, wherein the first and/or second asparagine-responsive active areas further comprise a polymer.
- [0436] C15. The analyte sensor of C14, wherein the first asparaginase is covalently bonded to the polymer and/or the second asparaginase is covalently bonded to the polymer.
- 5 [0437] C16. The analyte sensor of C14 or C15, wherein the first and/or second electron transfer agent is covalently bonded to the polymer.
- [0438] C17. The analyte sensor of any one of C10-C16, wherein the first and/or second electron transfer agent are the same.
- [0439] C18. The analyte sensor of any one of C1-C17, wherein the first mass transport limiting membrane comprises a polyvinylpyridine-based polymer, a polyvinylimidazole, 10 a polyacrylate, a polyurethane, a polyether urethane, a silicone or a combination thereof.
- [0440] C19. The analyte sensor of C18, wherein the first mass transport limiting membrane comprises a polyvinylpyridine-based polymer.
- [0441] C20. The analyte sensor of C18, wherein the first mass transport limiting membrane comprises a polyurethane. 15
- [0442] C21. The analyte sensor of C18, wherein the first mass transport limiting membrane comprises a silicone.
- [0443] C22. The analyte sensor of C18, wherein the first mass transport limiting membrane comprises polyvinylpyridine.
- 20 [0444] C23. The analyte sensor of C18, wherein the first mass transport limiting membrane comprises a copolymer of vinylpyridine and styrene.
- [0445] C24. The analyte sensor of C-C23, further comprising:
- (iv) a third working electrode; and
  - (v) a third active area disposed upon a surface of the third working electrode and 25 responsive to a second analyte differing from potassium, wherein the third active area comprises at least one enzyme responsive to the second analyte.
- [0446] C25. The analyte sensor of C24, further comprising a second portion of the mass transport limiting membrane overcoats the third active area.
- [0447] C26. The analyte sensor of C24, further comprising a second mass transport limiting membrane overcoats the third active area. 30
- [0448] C27. The analyte sensor of C26, wherein the second mass transport limiting membrane further overcoats the first asparagine-responsive active area and/or the second asparagine-responsive active area.
- [0449] C28. The analyte sensor of C26 or C27, wherein the second mass transport limiting

membrane comprises a polymer that is not in the first mass transport limiting membrane.

5 [0450] C29. The analyte sensor of any one of C-C28, wherein the first asparagine-responsive active area comprises a first enzymatic layer comprising the aspartate oxidase and a second enzymatic layer comprising the first asparaginase disposed upon the first enzyme layer.

[0451] C30. The analyte sensor of any one of C-C29, wherein the second asparagine-responsive active area comprises a first enzymatic layer comprising the aspartate oxidase and a second enzymatic layer comprising the second asparaginase disposed upon the first enzyme layer.

10 [0452] C31. The analyte sensor of any one of C-C28, wherein the first asparagine-responsive active area includes an enzymatic layer comprising the first aspartate oxidase and the first asparaginase.

[0453] C32. The analyte sensor of any one of C-C29 and C31, wherein the second asparagine-responsive active area includes an enzymatic layer comprising the second aspartate oxidase and the second asparaginase.

15 [0454] D. In certain non-limiting embodiments, the presently disclosed subject matter provides for analyte sensors for measuring potassium levels comprising:

(i) a sensor tail comprising at least a first working electrode and a second working electrode;

20 (ii) a first analyte-responsive active area disposed upon a surface of the first working electrode comprising a first enzymatic layer comprising a first aspartate oxidase and a second enzymatic layer comprising a first asparaginase; and

(iii) a second analyte-responsive active area disposed upon a surface of the second working electrode comprising a first enzymatic layer comprising a second aspartate oxidase and a second enzymatic layer comprising a second asparaginase.

25 [0455] D1. The analyte sensor of D, wherein the second enzymatic layer of the first analyte-responsive active area is disposed upon the first enzymatic layer of the first analyte-responsive active area and/or wherein the second enzymatic layer of the second analyte-responsive active area is disposed upon the first enzymatic layer of the second analyte-responsive active area.

[0456] D2. The analyte sensor of D or D1, wherein the first asparaginase is a potassium-dependent asparaginase.

30 [0457] D3. The analyte sensor of any one of D-D2, wherein the second asparaginase is a potassium-independent asparaginase.

- [0458] D4. The analyte sensor of D or D1, wherein the first asparaginase and second asparaginase are potassium-dependent asparaginases.
- [0459] D5. The analyte sensor of D4, wherein the first asparaginase and the second asparaginase exhibit different potassium dependencies.
- 5 [0460] D6. The analyte sensor of any one of D-D5, wherein the first asparagine-responsive active area further comprises an electron transfer agent.
- [0461] D7. The analyte sensor of any one of D-D6, wherein the first asparagine-responsive active area further comprises a stabilizing agent.
- [0462] D8. The analyte sensor of D7, wherein the stabilizing agent is an albumin.
- 10 [0463] D9. The analyte sensor of D8, wherein the albumin is bovine serum albumin.
- [0464] D10. The analyte sensor of any one of D-D9, wherein the second asparagine-responsive active area further comprises an electron transfer agent.
- [0465] D11. The analyte sensor of any one of D-D10, wherein the second asparagine-responsive active area further comprises a stabilizing agent.
- 15 [0466] D12. The analyte sensor of D11, wherein the stabilizing agent is an albumin.
- [0467] D13. The analyte sensor of D12, wherein the albumin is bovine serum albumin.
- [0468] D14. The analyte sensor of any one of D-D13, wherein the first and/or second asparagine-responsive active areas further comprise a polymer.
- [0469] D15. The analyte sensor of D14, wherein the first asparaginase is covalently  
20 bonded to the polymer and/or the second asparaginase is covalently bonded to the polymer.
- [0470] D16. The analyte sensor of D14 or D15, wherein the first and/or second electron transfer agent is covalently bonded to the polymer.
- [0471] D17. The analyte sensor of any one of D10-D16, wherein the first and second electron transfer agent are the same.
- 25 [0472] D18. The analyte sensor of any one of D1-D17, further comprising a first mass transport limiting membrane permeable to potassium that overcoats the first analyte-responsive active area and/or the second analyte-responsive active area.
- [0473] D19. The analyte sensor of D18, wherein the first mass transport limiting membrane comprises a polyvinylpyridine-based polymer, a polyvinylimidazole, a  
30 polyacrylate, a polyurethane, a polyether urethane, a silicone or a combination thereof.
- [0474] D20. The analyte sensor of D19, wherein the first mass transport limiting membrane comprises a polyvinylpyridine-based polymer.
- [0475] D21. The analyte sensor of D19, wherein the first mass transport limiting membrane comprises a polyurethane.



- [0476] D22. The analyte sensor of D19, wherein the first mass transport limiting membrane comprises a silicone.
- [0477] D23. The analyte sensor of D19, wherein the first mass transport limiting membrane comprises polyvinylpyridine.
- 5 [0478] D24. The analyte sensor of D19, wherein the first mass transport limiting membrane comprises a copolymer of vinylpyridine and styrene.
- [0479] D25. The analyte sensor of D-D24, further comprising:
- (iv) a third working electrode; and
  - (v) a third active area disposed upon a surface of the third working electrode and
- 10 responsive to a second analyte differing from potassium, wherein the third active area comprises at least one enzyme responsive to the second analyte.
- [0480] D26. The analyte sensor of D25, further comprising a second portion of the mass transport limiting membrane overcoats the third active area.
- [0481] D27. The analyte sensor of D25, further comprising a second mass transport
- 15 limiting membrane overcoats the third active area.
- [0482] D28. The analyte sensor of D27, wherein the second mass transport limiting membrane further overcoats the first asparagine-responsive active area and/or the second asparagine-responsive active area.
- [0483] D29. The analyte sensor of D27 or D28, wherein the second mass transport limiting
- 20 membrane comprises a polymer that is not in the first mass transport limiting membrane.
- [0484] E. In certain non-limiting embodiments, the presently disclosed subject matter provides for methods for detecting potassium ions in a fluid using the analyte sensors of any one of A-D29.
- [0485] F. In certain non-limiting embodiments, the presently disclosed subject matter
- 25 provides for methods for detecting potassium ions in a fluid comprising:
- (i) providing an analyte sensor of any one of A-D29;
  - (ii) applying a potential to the first working electrode and the second working electrode;
  - (iii) obtaining a first signal at or above an oxidation-reduction potential of the
- 30 first analyte-responsive active area, first aspartate-responsive active area or first asparagine-responsive active area;
- (iv) obtaining a second signal at or above an oxidation-reduction potential of the second analyte-responsive active area, second aspartate-responsive active area or second asparagine-responsive active area; and

(v) correlating the first signal and the second signal to the concentration of the potassium ions in the fluid.

[0486] F1. The method of F, wherein the fluid is interstitial fluid.

[0487] F2. The method of F or F1, wherein the analyte sensor is implanted in a subject at risk of or having a neurological condition or diabetes.

[0488] F3. The method of any one of F-F2, wherein the sensor tail is configured to be implanted in a subject.

[0489] F4. The method of any one of F-F3, wherein the analyte sensor is implanted in a subject for at least about 15 days.

10

### **EXAMPLES**

[0490] The presently disclosed subject matter will be better understood by reference to the following Examples, which are provided as exemplary of the presently disclosed subject matter, and not by way of limitation.

15

#### ***Example 1: Potassium Sensor with an Enzyme System Comprising Aspartate Oxidase and Asparaginase***

[0491] The present example provides sensors for indirectly detecting potassium ion concentrations by analysis of asparagine levels in a sample. The enzyme system of FIG. 22 was used to indirectly detect potassium ions. Each sensor includes an aspartate sensing layer that is disposed upon a working electrode and an asparaginase layer disposed upon the aspartate sensing layer. Each sensor includes a different asparaginase, where each asparaginase differs in their dependency on potassium.

[0492] The chemical composition for the aspartate sensing layer is shown in Table 1, which includes an L-aspartate oxidase, a redox mediator, bovine serum albumin (BSA) and the crosslinker, polyethylene glycol diglycidyl ether 400 (PEGDGE400). The chemical compositions for four different types of asparaginase layers are shown in Tables 2-5, each of which include an asparaginase, BSA and PEGDGE400. The asparaginases in Table 2 and Table 4 were prepared according to procedures in Ajewole et al., FEBS Journal 285(8):1528-1539 (2018) and Bejger et al., Acta Crystallogr. D. Biol. Crystallogr. 70(Pt 7):1854-72 (2014). The wild type was PvAspG1 and the mutant asparaginase was a mutant version of PvAspG1 at amino acid position 118. The asparaginases in Tables 3 and 5 were purchased from Sigma (Catalogue No. A3809) and ProSpec (Catalogue No. ENZ-287).

30

Table 1

Component	Final Conc. (mg/mL)
L-aspartate oxidase	17.76
BSA	8
Redox Mediator	8
PEGDGE400	8

Table 2

Component	Final Conc. (mg/mL)
Wild-type Asparaginase	6.96
BSA	8
PEGDGE400	8

5

Table 3

Component	Final Conc. (mg/mL)
Sigma Asparaginase	0.2
BSA	8
PEGDGE400	8

Table 4

Component	Final Conc. (mg/mL)
Mutant Asparaginase	6.96
BSA	8
PEGDGE400	8

Table 5

Component	Final Conc. (mg/mL)
ProSpec Asparaginase	0.2
BSA	8
PEGDGE400	8

10

[0493] To make the sensors, the components of the aspartate sensing layer were first mixed and incubated for 30 minutes at room temperature in 10 mM PBS buffer and deposited twice on a working electrode. The resulting sensing layer was cured. Asparaginase layers were formed by depositing the asparagine sensing chemistry formulations from Tables 2-5 onto the aspartate sensing layer and cured.

15

[0494] The sensors were then tested in 100 mM TRIS-HCl buffer at pH 7.5 at 33°C. As shown in FIG. 26, asparagine was first added at a concentration of 100  $\mu$ M and then at a concentration of 400  $\mu$ M. All sensors responded to the additions of asparagine.

Subsequently, 1 mM, 3 mM and 7 mM of potassium nitrate were added to the solution. As shown in FIG. 26, the sensor response spiked immediately after addition of a new concentration of potassium nitrate (KNO<sub>3</sub>) followed by increasing over the course of several minutes before stabilizing thereafter. Table 6 summarizes the sensor signal increase in percent at different potassium concentrations relative to the sensor current at 400 μM asparagine with no potassium present. The data shown in FIG. 26 and in Table 6 are the average of 6 sensors for each type of asparaginase. It can be seen that all four types of sensors responded to potassium differently, indicating that such asparaginases can be included in a two-channel sensor as shown in FIG. 23 or FIG. 24 for detecting potassium levels in a sample.

Table 6

[KNO <sub>3</sub> ]	1 mM	3 mM	7 mM
Wild-6.96	294.8	535.4	730.0
Mutant-6.96	267.0	477.5	637.0
Sigma-0.2	87.4	123.3	140.6
Prospec-0.2	89.6	125.8	143.1

**Example 2: Potassium Sensor Comprising Aspartate Oxidase**

[0495] The present example provides sensors for indirectly detecting potassium ion concentrations by analysis of aspartate levels in a sample using a potassium-dependent enzyme. Each sensor includes an aspartate sensing layer disposed upon a carbon working electrode that includes the enzyme system of FIG. 27 to indirectly detect potassium ions. As shown in FIG. 27, the aspartate sensing layer includes a potassium-dependent aspartate oxidase and a redox mediator.

[0496] To make the sensors, the components of the aspartate sensing layer were mixed and incubated at room temperature in 10 mM PBS buffer for 30 minutes. Then 30 nL of the mixture was deposited twice on a working electrode, and cured overnight at 25°C under 60% relative humidity. The components for the aspartate sensing layer are shown in Table 7, which include an L-aspartate oxidase, a redox mediator, bovine serum albumin (BSA) and the crosslinker, polyethylene glycol diglycidyl ether 400 (PEGDGE400).

Table 7

Component	Final Conc. (mg/mL)
L-aspartate oxidase	17.76

BSA	8
Redox Mediator	16
PEGDGE400	8

[0497] The sensors were then tested in 20 mM TRIS buffer at pH 7.5 at 33°C. As shown in FIG. 28, the sensor was tested in the presence of 100 μM aspartate and 120 mM NaCl. Subsequently, 1 mM, 3 mM, 5 mM, 7 mM and 10 mM of potassium chloride (KCl) was added to the solution. As shown in FIG. 28, the sensor response spiked immediately after addition of a new KCl concentration and increased over the course of several minutes before stabilizing thereafter.

[0498] The sensors were tested in the presence of different concentrations of potassium and aspartate at a stable concentration of NaCl (130 mM). FIG. 29 shows the current response of a sensor in the presence of various concentrations of aspartate and potassium, and FIG. 30 provides the percentage increase in current response of the sensor in the presence of various concentrations of aspartate and potassium. As shown in FIGS. 29 and 30, the sensors can detect different potassium levels in the presence of different concentrations of aspartate, and that higher relative responses are observed at lower levels of aspartate.

\* \* \* \* \*

[0499] Although the presently disclosed subject matter and its advantages have been described in detail, it should be understood that various changes, substitutions and alterations can be made herein without departing from the spirit and scope of the disclosed subject matter. Moreover, the scope of the present application is not intended to be limited to the particular embodiments of the process, machine, manufacture, and composition of matter, methods and processes described in the specification. As one of ordinary skill in the art will readily appreciate from the disclosed subject matter of the presently disclosed subject matter, processes, machines, manufacture, compositions of matter, methods, or steps, presently existing or later to be developed that perform substantially the same function or achieve substantially the same result as the corresponding embodiments described herein can be utilized according to the presently disclosed subject matter. Accordingly, the appended claims are intended to include within their scope such processes, machines, manufacture, compositions of matter, methods, or steps.

[0500] Various patents, patent applications, publications, product descriptions, protocols, and sequence accession numbers are cited throughout this application, the inventions of which are incorporated herein by reference in their entireties for all purposes.

**WHAT IS CLAIMED IS:**

1. An analyte sensor for detecting potassium comprising:
  - (i) a sensor tail comprising at least a first working electrode and a second working electrode;
  - 5 (ii) a first analyte-responsive active area disposed upon a surface of the first working electrode, wherein the first analyte-responsive active area comprises a first aspartate oxidase;
  - (iii) a second analyte-responsive active area disposed upon a surface of the second working electrode, wherein the second analyte-responsive active area comprises a  
10 second aspartate oxidase; and
  - (iv) a first mass transport limiting membrane permeable to potassium that overcoats the first analyte-responsive active area and/or the second analyte-responsive area.
- 15 2. The analyte sensor of claim 1, wherein the first aspartate oxidase and the second aspartate oxidase have different potassium dependencies.
3. The analyte sensor of claim 1, wherein the first analyte-responsive active area further comprises a first asparaginase and/or the second analyte-responsive active area  
20 further comprises a second asparaginase.
4. The analyte sensor of claim 3, wherein the first asparaginase and the second asparaginase have different potassium dependencies.
- 25 5. The analyte sensor of any one of claims 1-4, wherein the first analyte-responsive active area and/or the second analyte-responsive active area further comprises an electron transfer agent.
6. The analyte sensor of any one of claims 1-5, wherein the first analyte-responsive  
30 active area and/or the second analyte-responsive active area further comprises a stabilizing agent.
7. The analyte sensor of any one of claims 1-6, wherein the first mass transport limiting membrane comprises a polyvinylpyridine-based polymer, a polyvinylimidazole,

a polyacrylate, a polyurethane, a polyether urethane, a silicone or a combination thereof.

8. The analyte sensor of any one of claims 3-7, wherein:

5 (a) the first analyte-responsive active area comprises a first enzymatic layer comprising the first aspartate oxidase and a second enzymatic layer comprising the first asparaginase disposed upon the first enzymatic layer; and/or

(b) the second analyte-responsive active area comprises a first enzymatic layer comprising the second aspartate oxidase and a second enzymatic layer comprising the second asparaginase disposed upon the first enzymatic layer.

10

9. The analyte sensor of any one of claims 3-7, wherein:

(a) the first analyte-responsive active area comprises a first enzymatic layer comprising the first aspartate oxidase and the first asparaginase; and/or

15 (b) the second analyte-responsive active area comprises a first enzymatic layer comprising the second aspartate oxidase and the second asparaginase.

10. A method for measuring the level of potassium in a subject using the analyte sensor of any one of claims 1-9.

20 11. A method for detecting potassium ions in a fluid comprising:

(i) providing an analyte sensor comprising:

(a) a first analyte-responsive active area disposed upon a surface of the first working electrode, wherein the first analyte-responsive active area comprises a first aspartate oxidase;

25 (b) a second analyte-responsive active area disposed upon a surface of the second working electrode, wherein the second analyte-responsive active area comprises a second aspartate oxidase; and

(c) a first mass transport limiting membrane permeable to potassium that overcoats the first analyte-responsive active area and/or the second analyte-responsive area;

30 (ii) applying a potential to the first working electrode and the second working electrode;

(iii) obtaining a first signal at or above an oxidation-reduction potential of the first analyte-responsive active area;



(iv) obtaining a second signal at or above an oxidation-reduction potential of the second analyte-responsive active area; and

(v) correlating the first signal and the second to the concentration of potassium ions in the fluid.

5

12. The method of claim 11, wherein the first aspartate oxidase and the second aspartate oxidase have different potassium dependencies.

13. The method of claim 11 or 12, wherein the first analyte-responsive active area further comprises a first asparaginase and/or the second analyte-responsive active area further comprises a second asparaginase.

10

14. The method of claim 13, wherein the first asparaginase and the second asparaginase have different potassium dependencies.

15

15. The method of any one of claims 11-14, wherein the first analyte-responsive active area and/or the second analyte-responsive active area further comprises an electron transfer agent.

20

16. The method of any one of claims 11-15, wherein the first analyte-responsive active area and/or the second analyte-responsive active area further comprises a stabilizing agent.

25

17. The method of any one of claims 11-16, wherein the first mass transport limiting membrane comprises a polyvinylpyridine-based polymer, a polyvinylimidazole, a polyacrylate, a polyurethane, a polyether urethane, a silicone or a combination thereof.

18. The method of any one of claims 11-17, wherein:

30

(a) the first analyte-responsive active area comprises a first enzymatic layer comprising the first aspartate oxidase and a second enzymatic layer comprising the first asparaginase disposed upon the first enzymatic layer; and/or

(b) the second analyte-responsive active area comprises a first enzymatic layer comprising the second aspartate oxidase and a second enzymatic layer comprising the second asparaginase disposed upon the first enzymatic layer.

19. The method of any one of claims 11-17, wherein:
- (a) the first analyte-responsive active area comprises a first enzymatic layer comprising the first aspartate oxidase and the first asparaginase; and/or
  - 5 (b) the second analyte-responsive active area comprises a first enzymatic layer comprising the second aspartate oxidase and the second asparaginase.
20. The method of any one of claims 11-19, wherein:
- (a) the fluid is interstitial fluid;
  - 10 (b) the analyte sensor is implanted in a subject at risk of or having a neurological condition or diabetes;
  - (c) the sensor tail is configured to be implanted in a subject; and/or
  - (d) the analyte sensor is implanted in a subject for at least about 15 days.

15

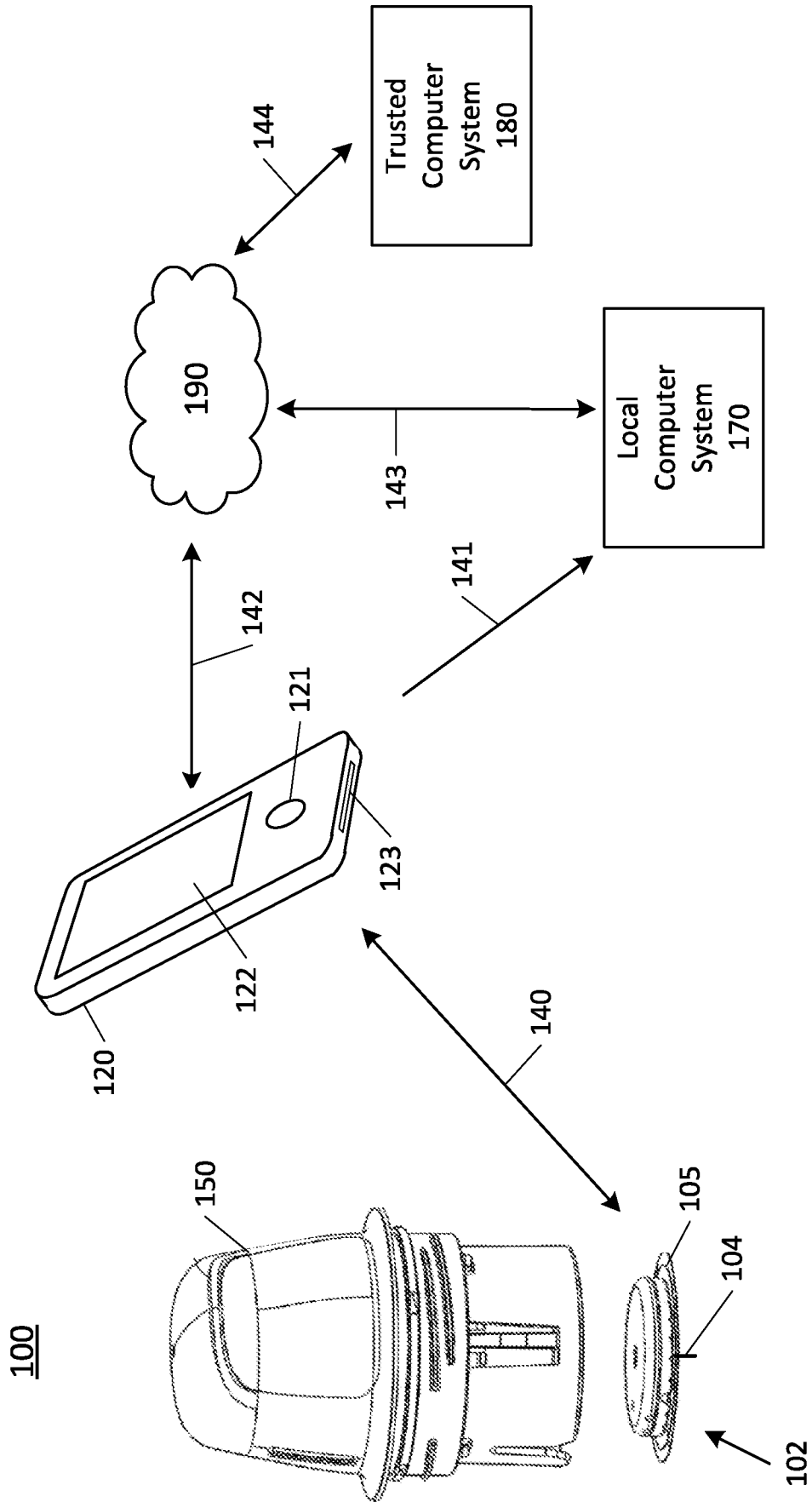

FIG. 1 A

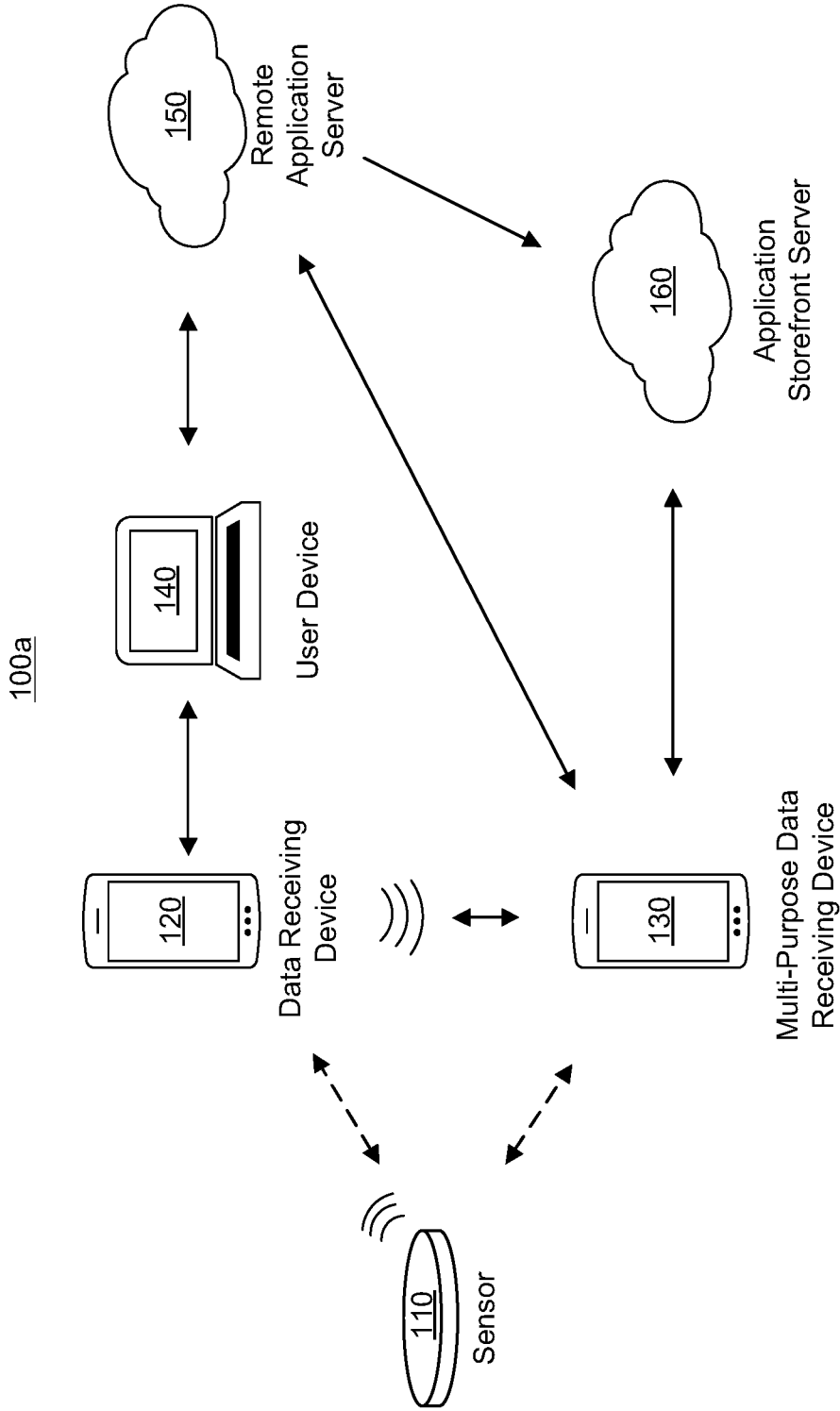

FIG. 1B

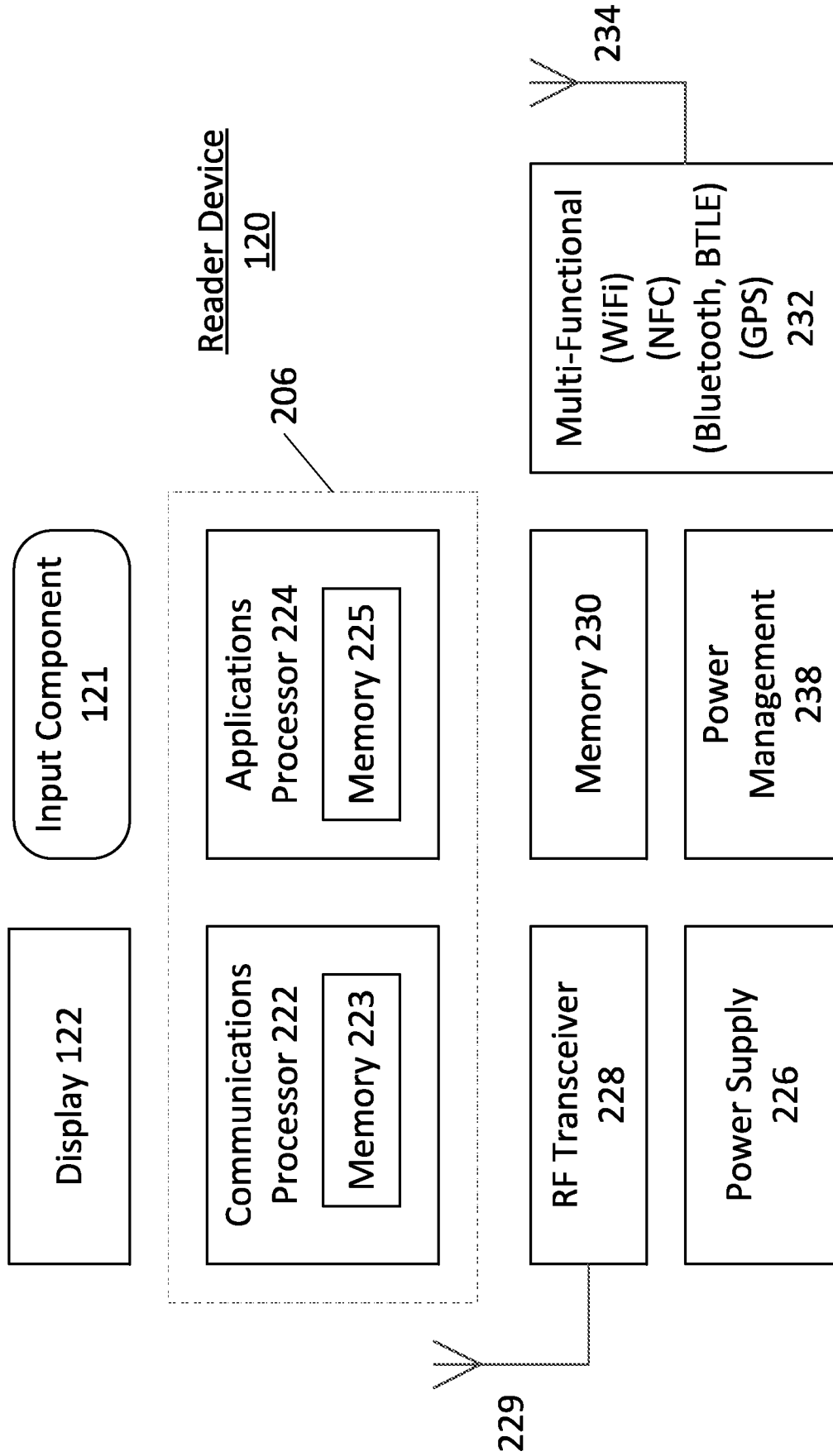

FIG. 2A

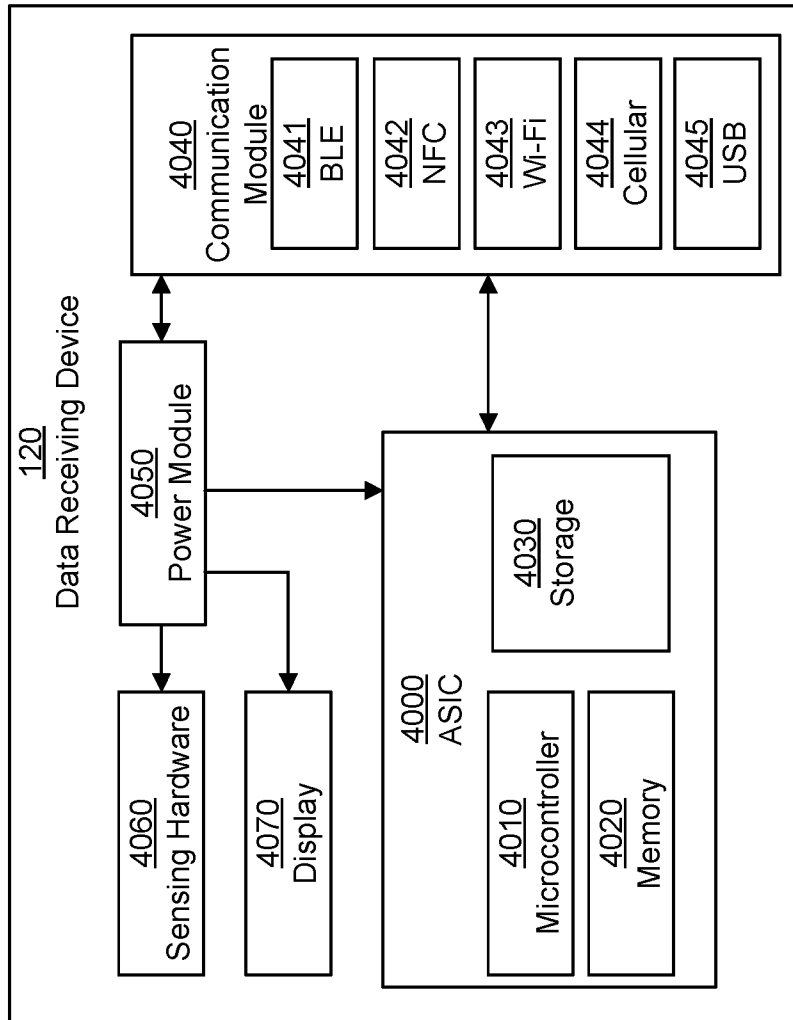

FIG. 2B

FIG. 2C

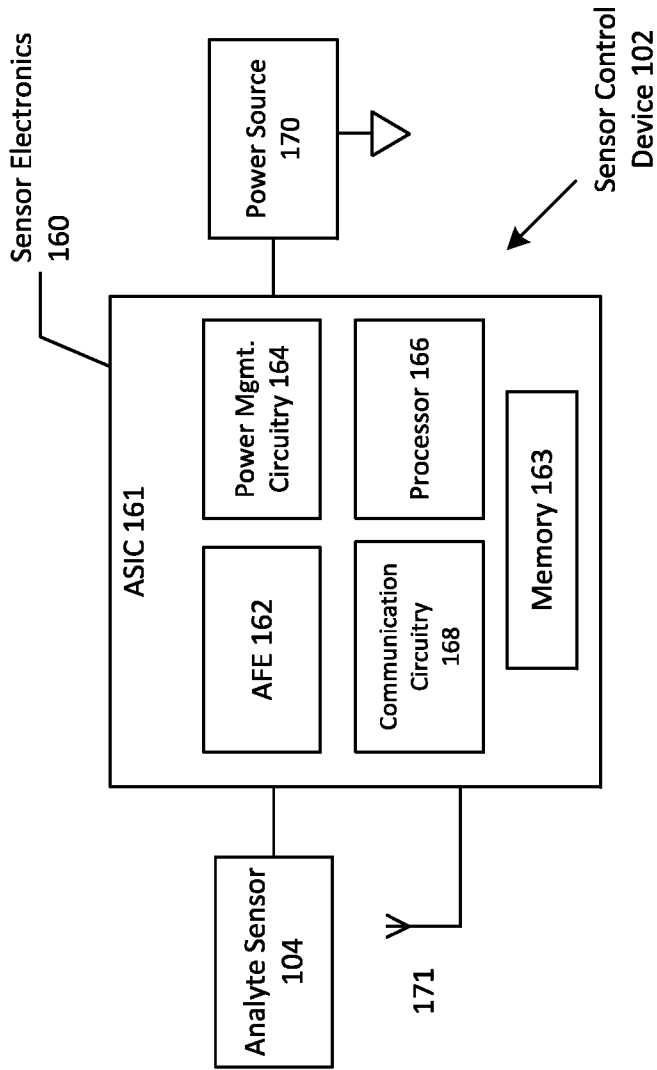
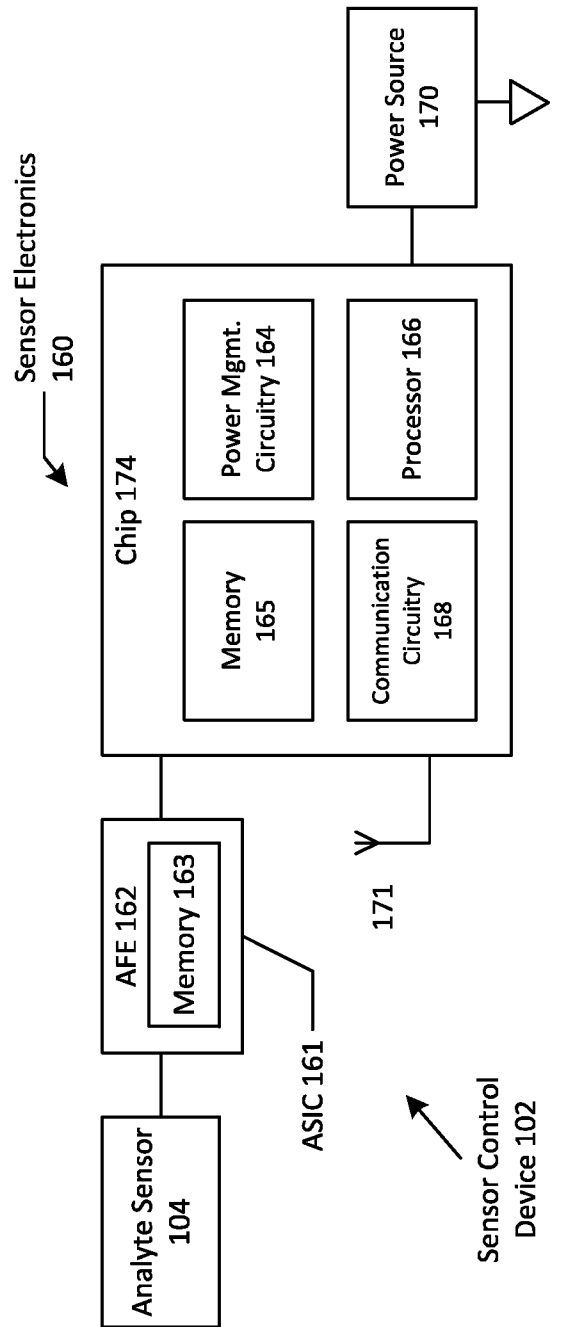

FIG. 2D



110  
Sensor

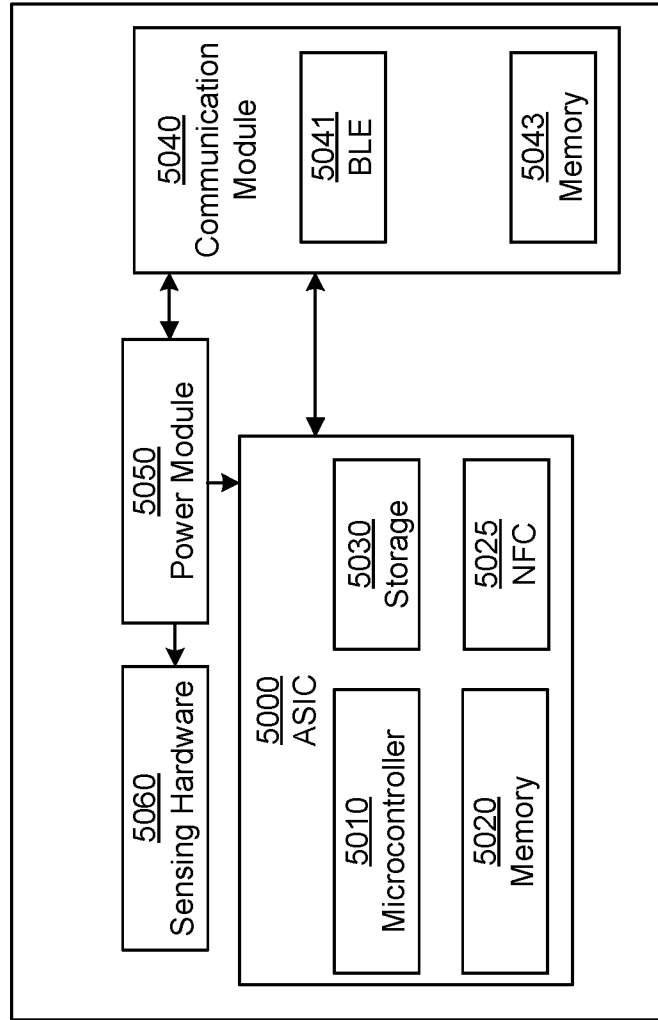

FIG. 2E



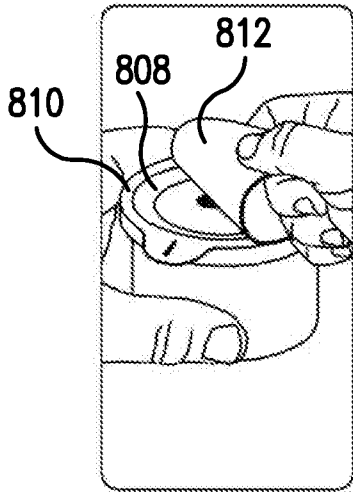

FIG. 3A

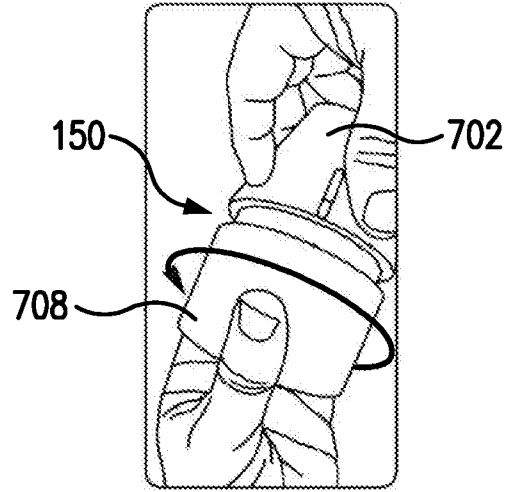

FIG. 3B

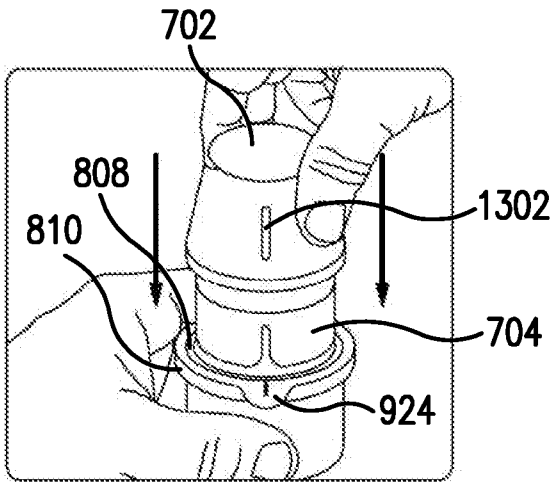

FIG. 3C

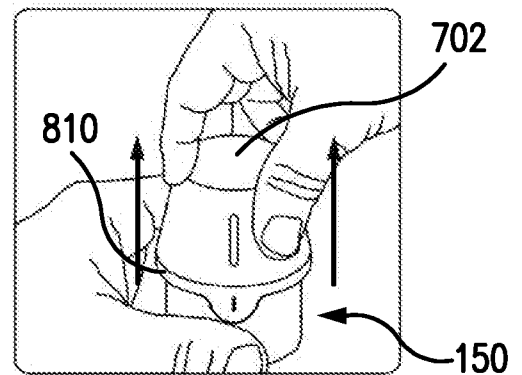

FIG. 3D

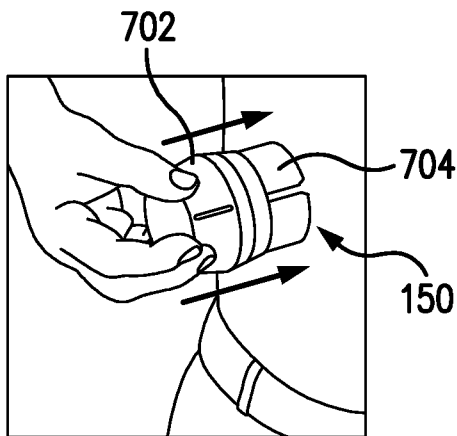

FIG. 3E

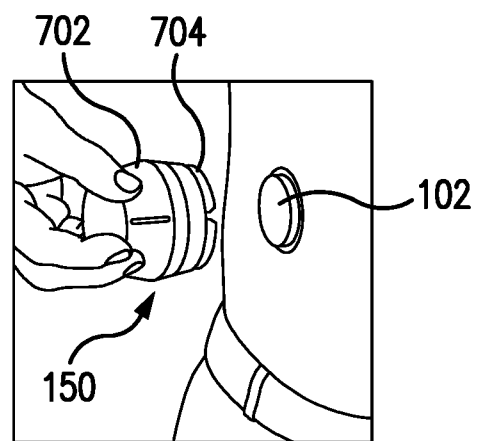

FIG. 3F

FIG. 4C

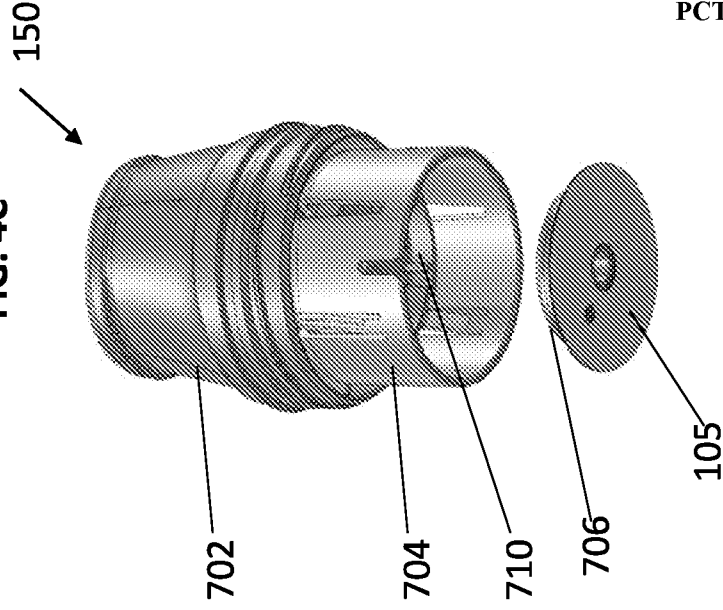

FIG. 4B

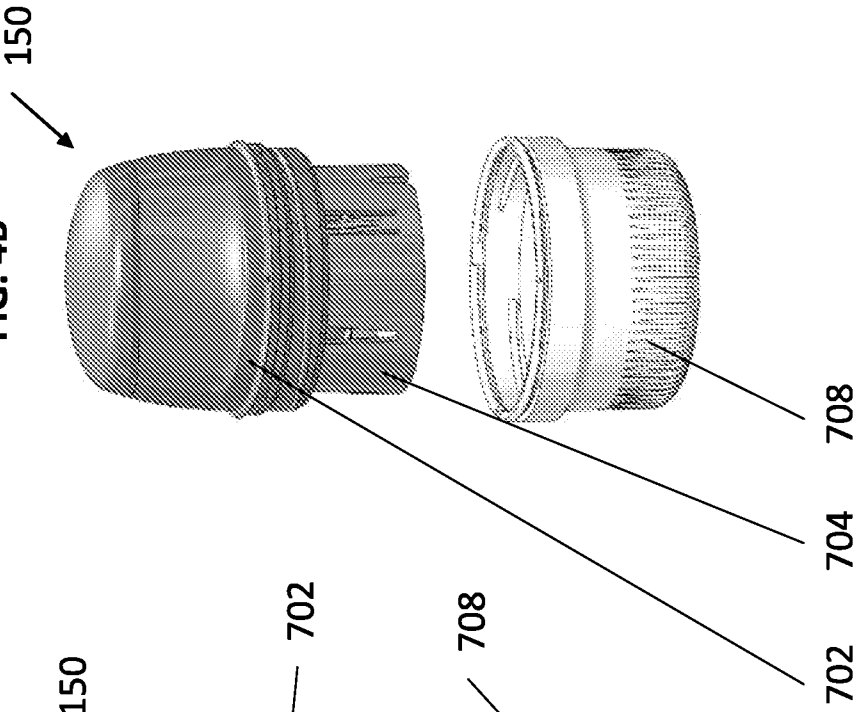
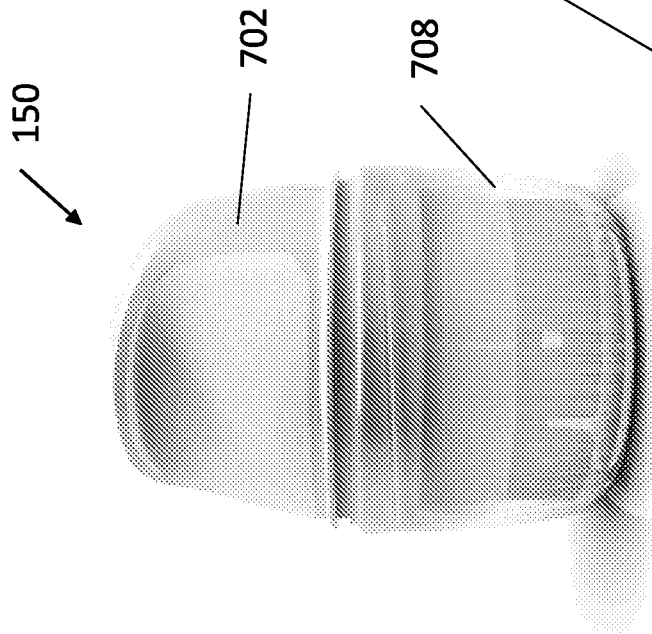

FIG. 4A



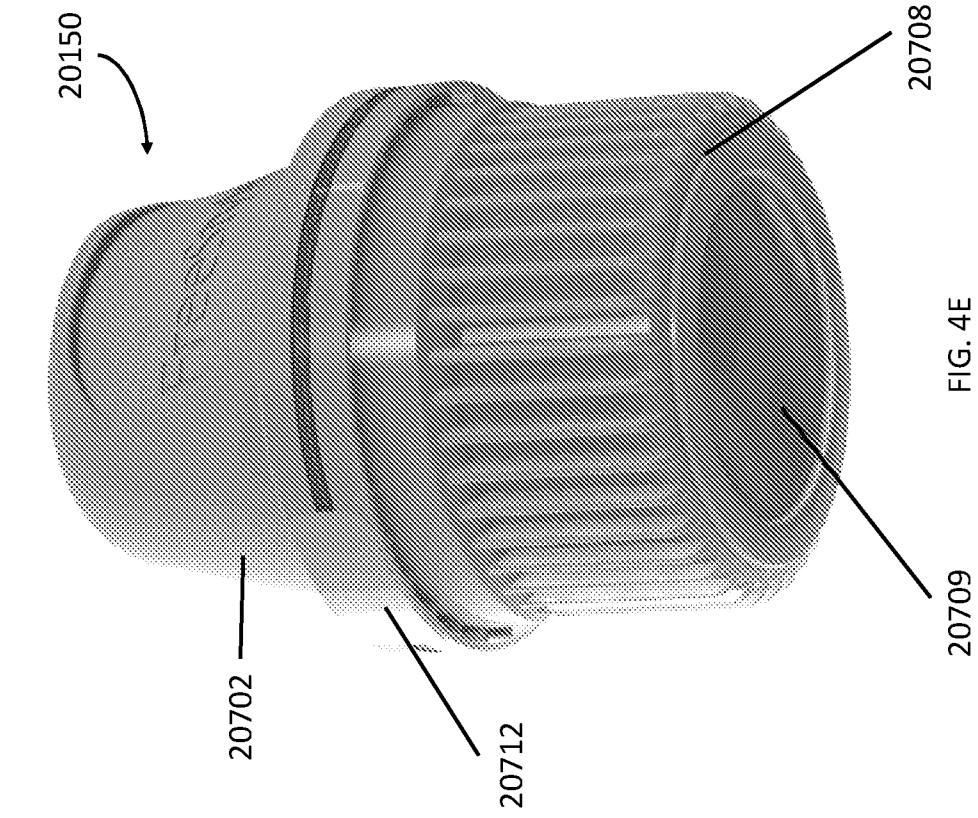

FIG. 4E

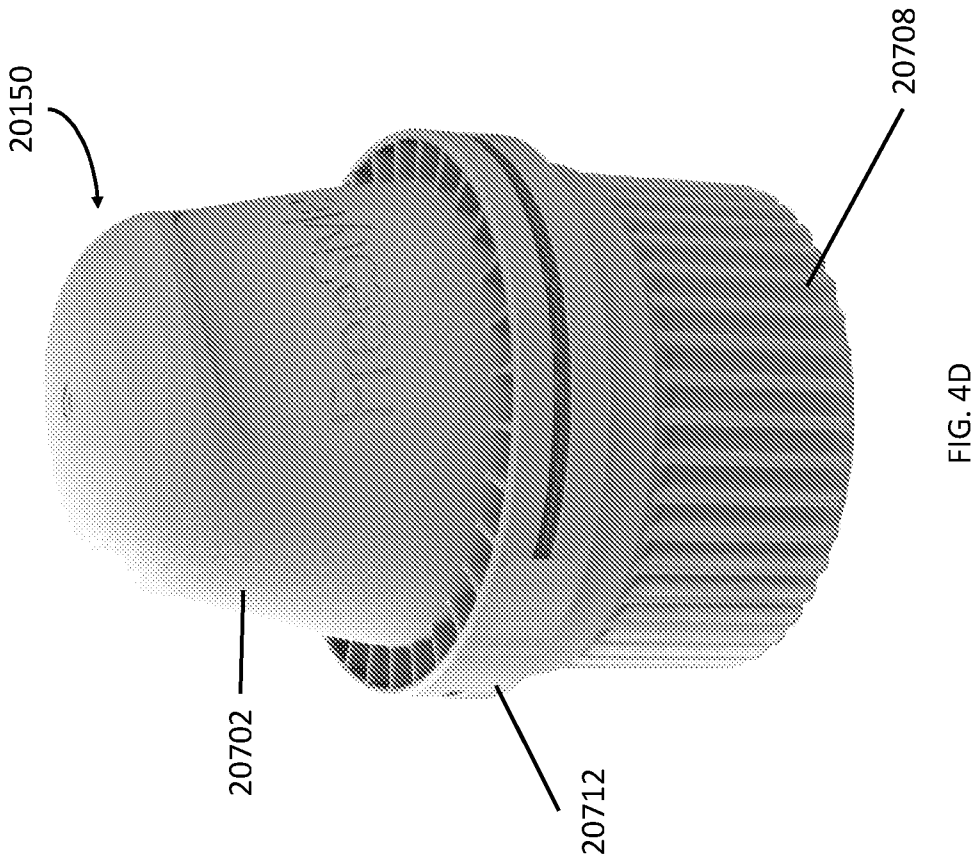

FIG. 4D

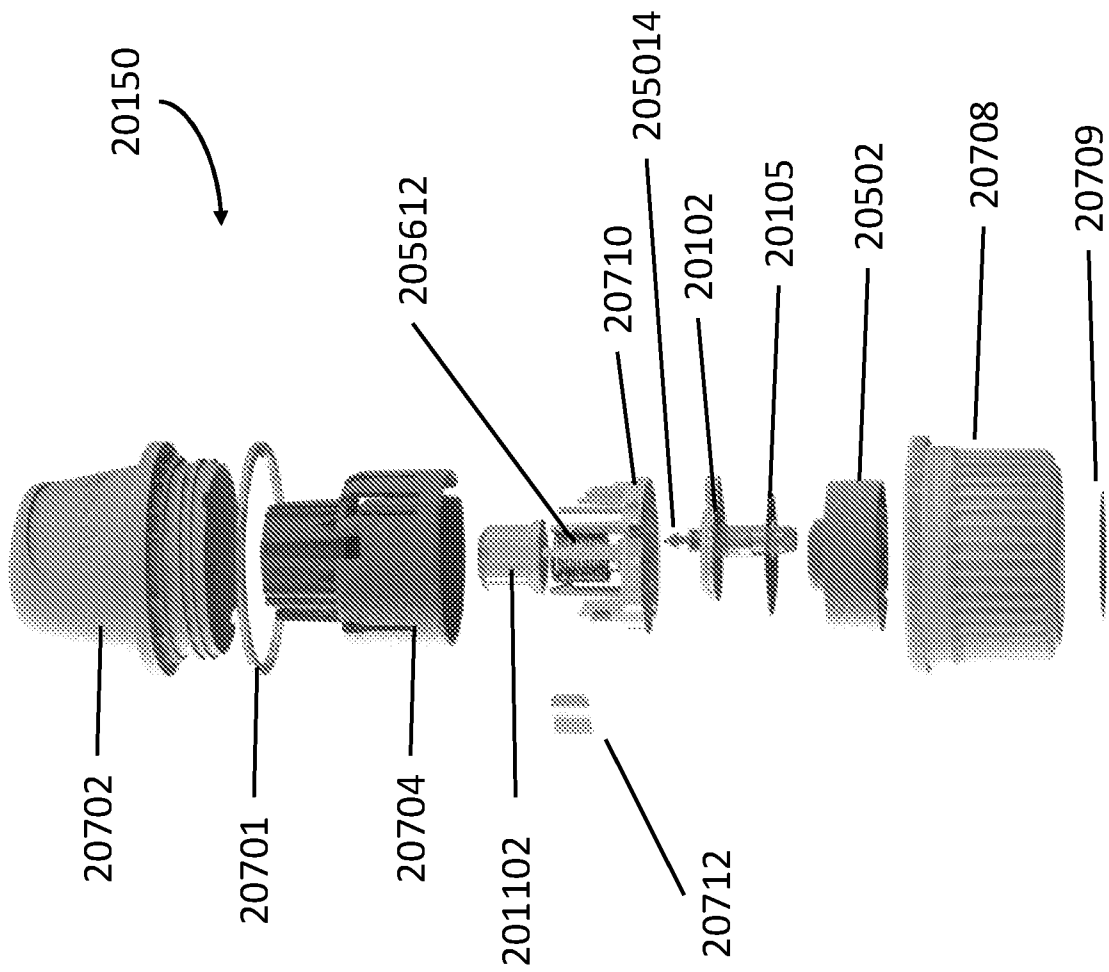

FIG. 4F

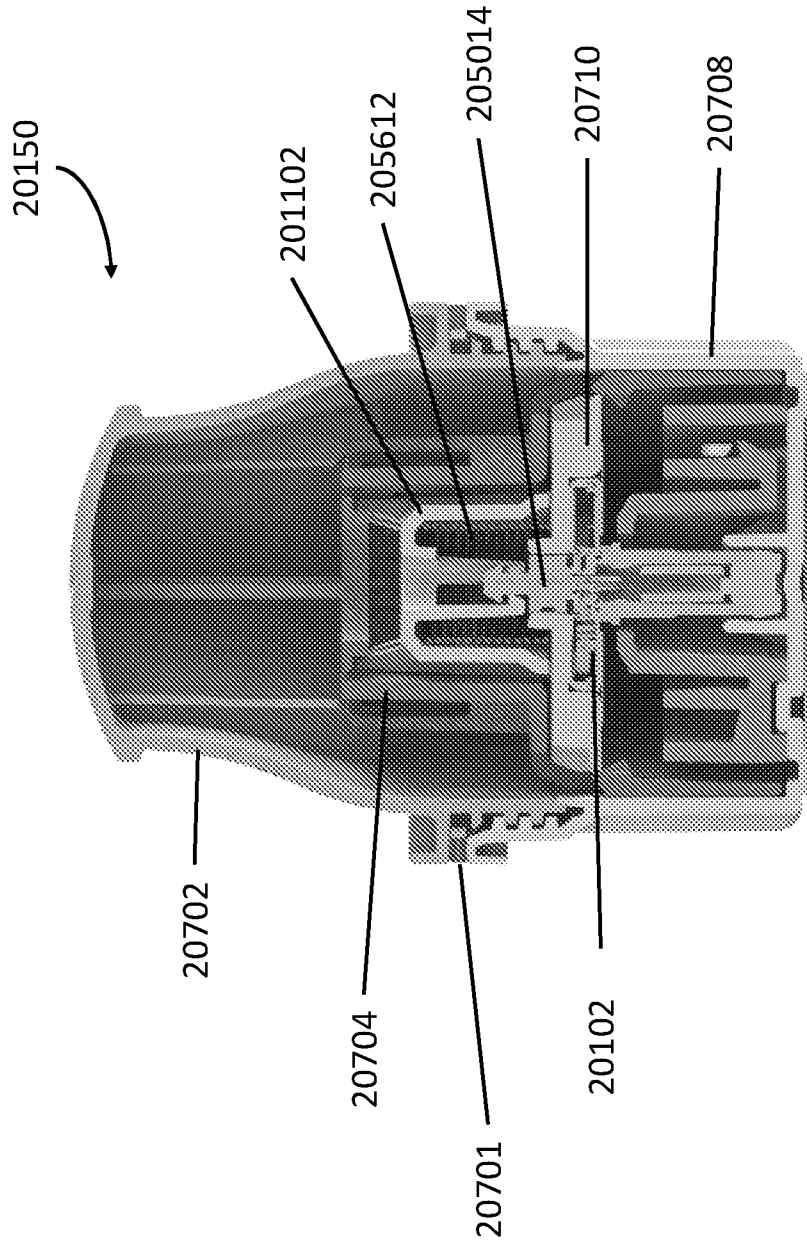

FIG. 4G

FIG. 6A

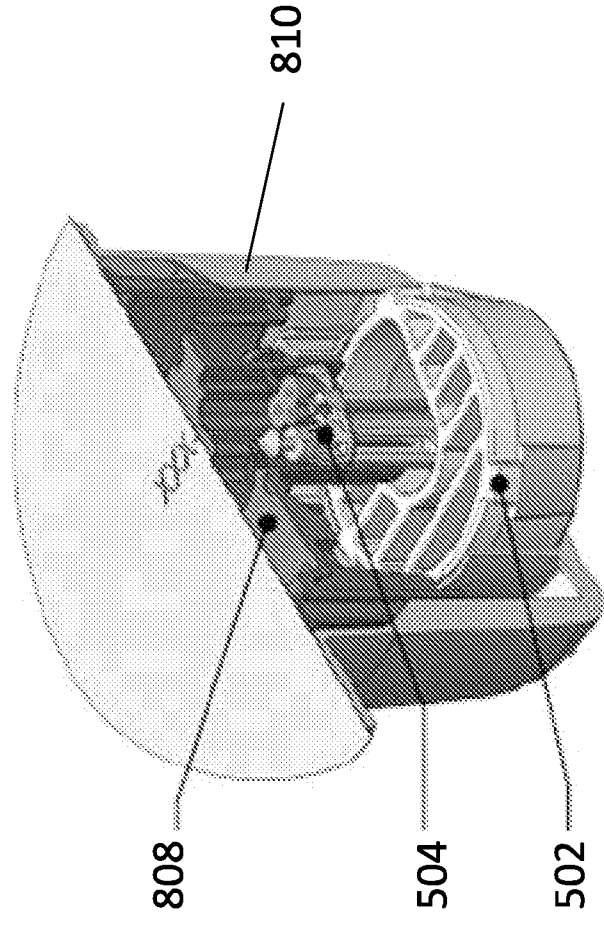
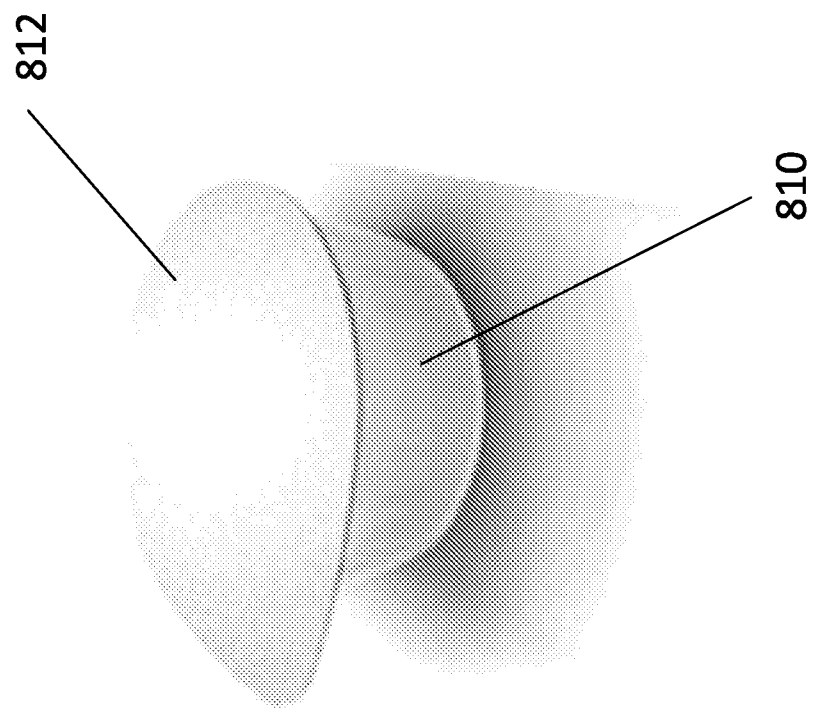

FIG. 5



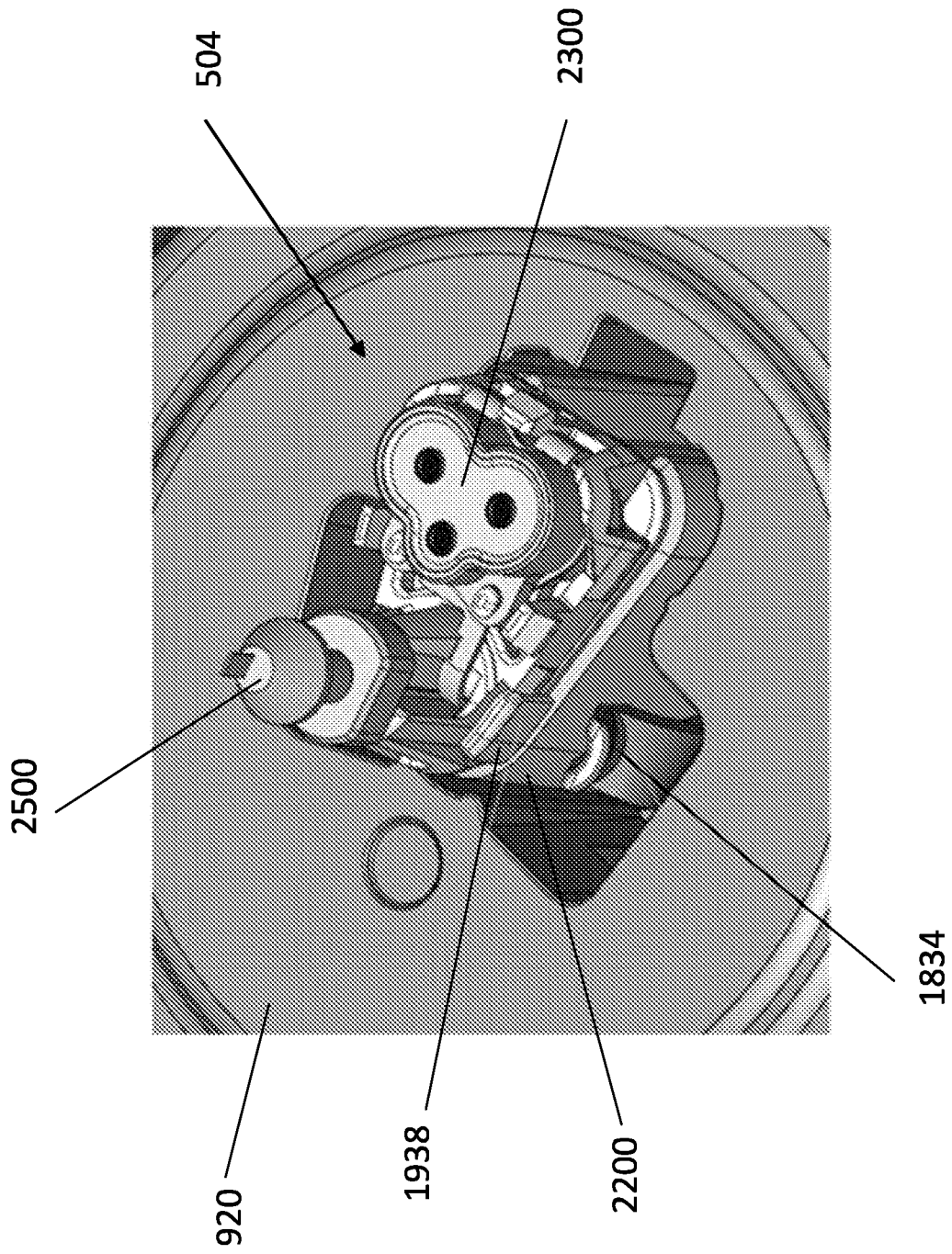

FIG. 6B

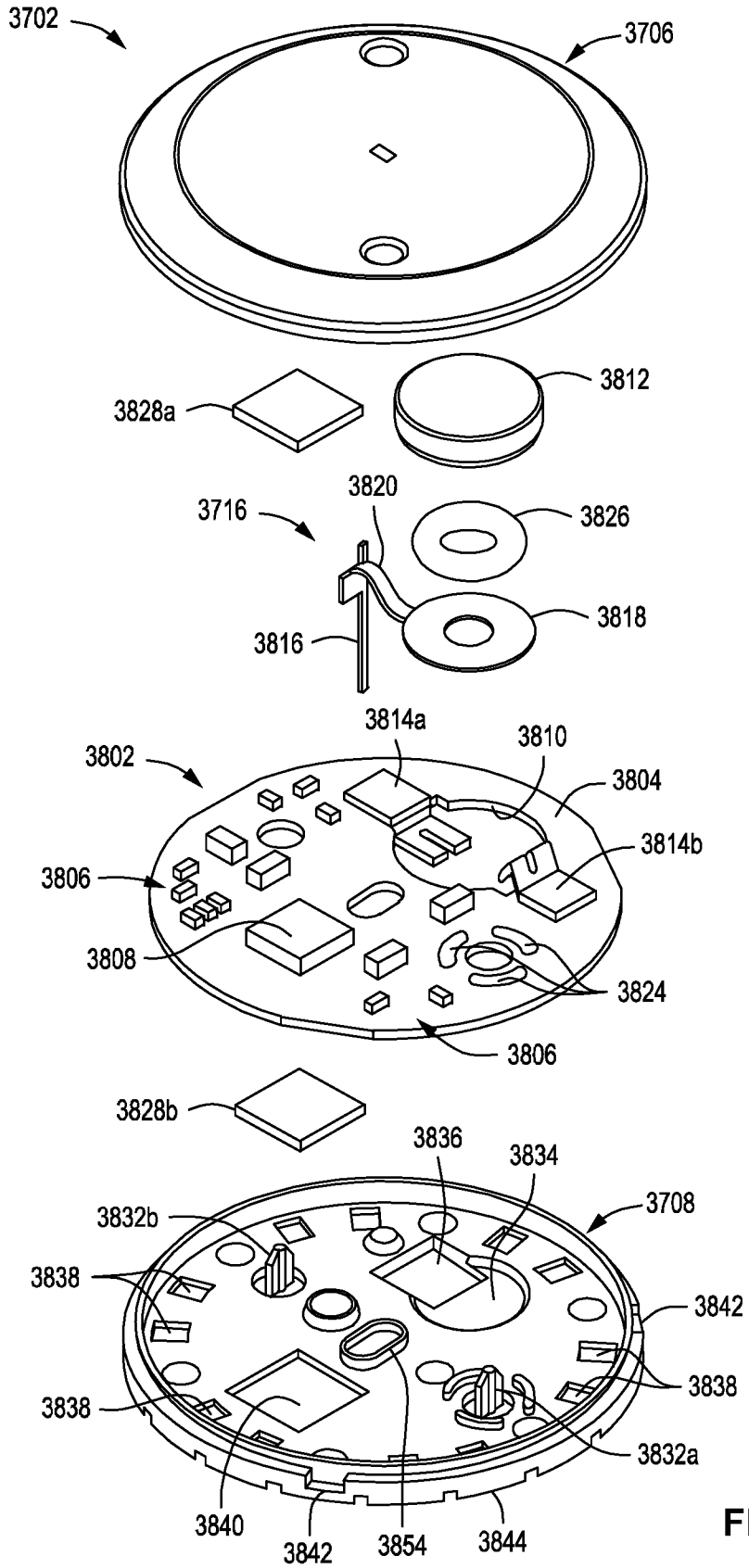

FIG. 7A



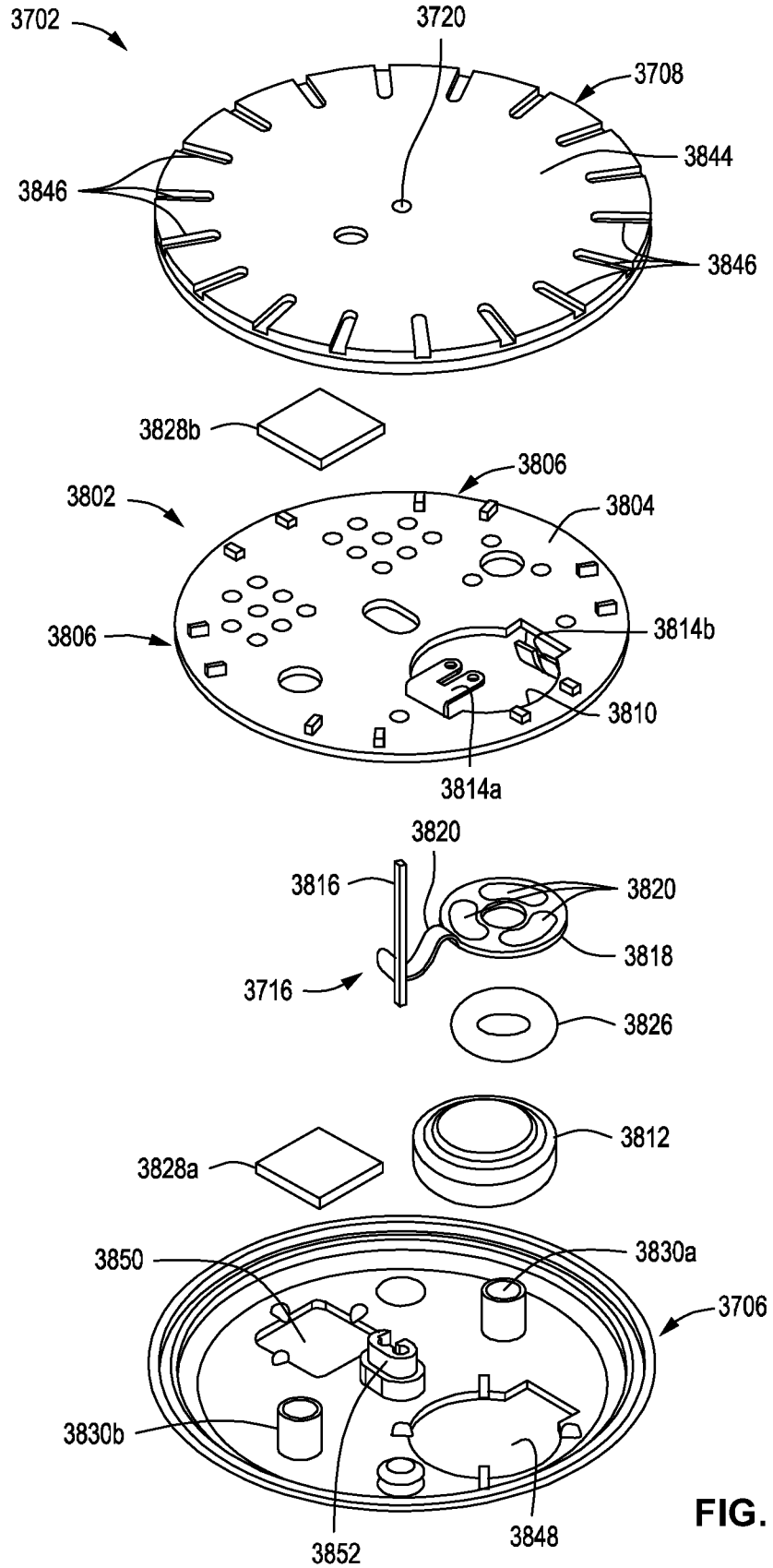

FIG. 7B

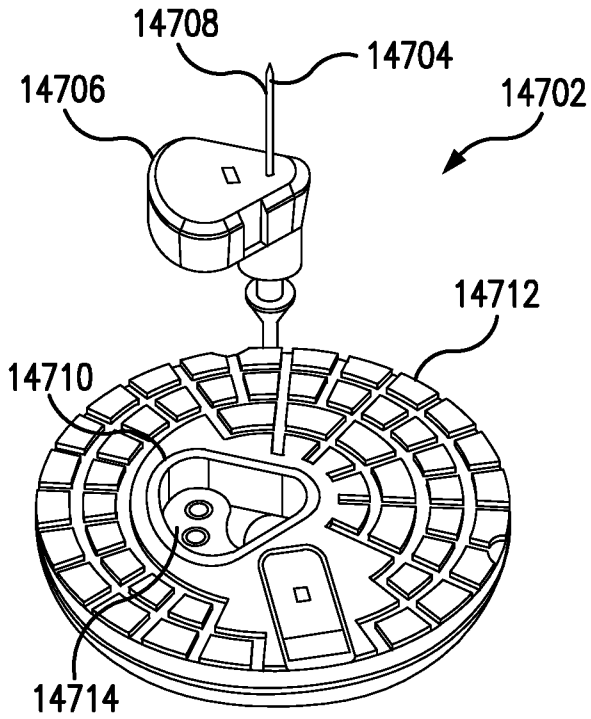

FIG. 8A

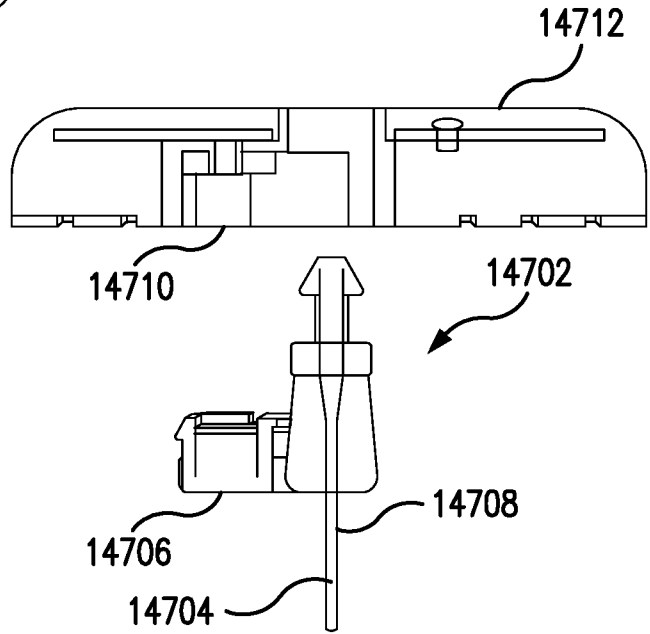

FIG. 8B

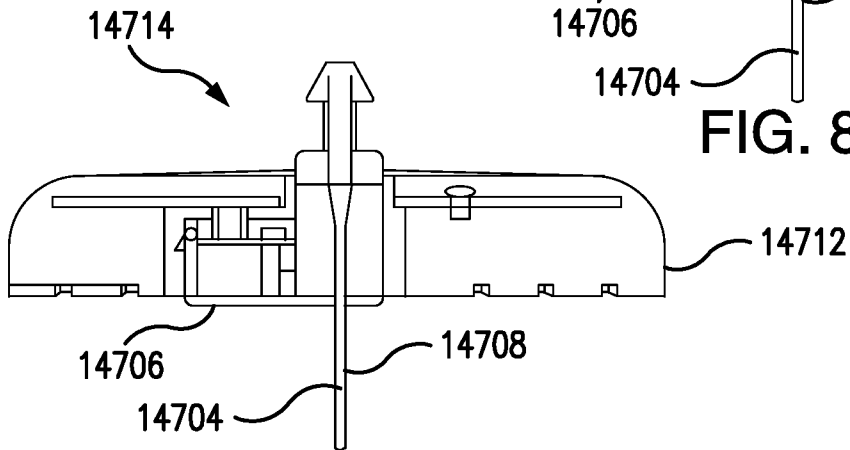

FIG. 8C

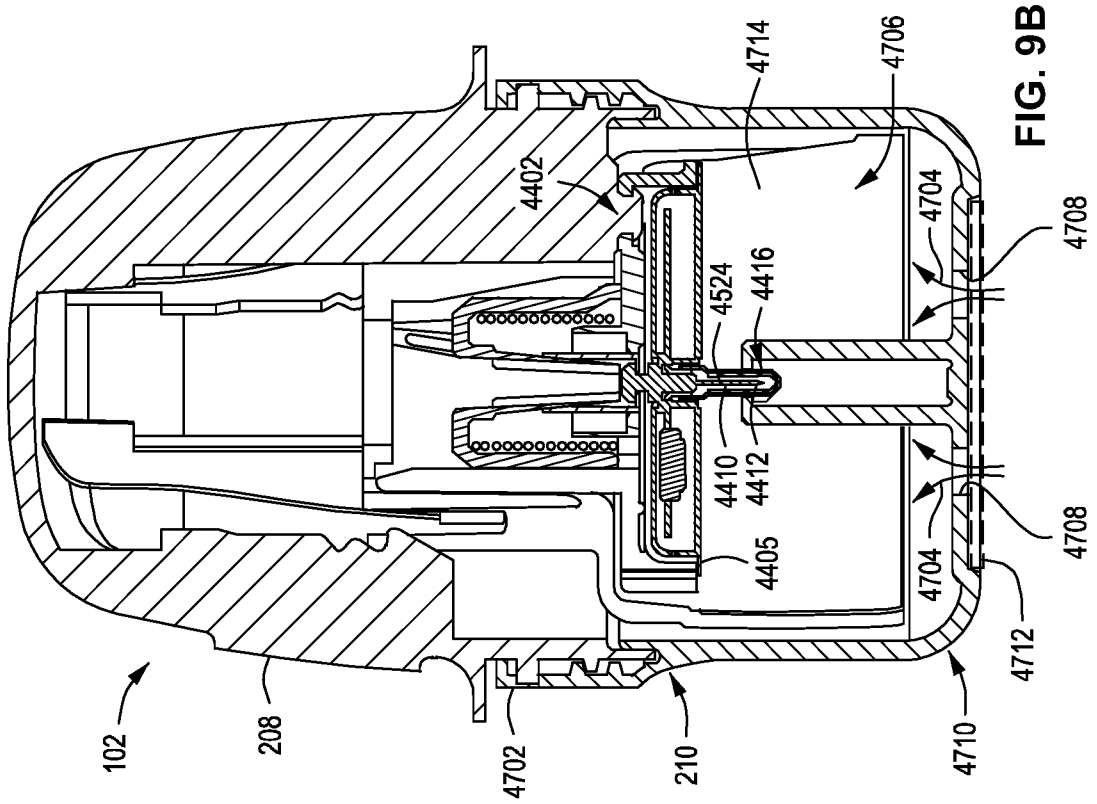

FIG. 9A

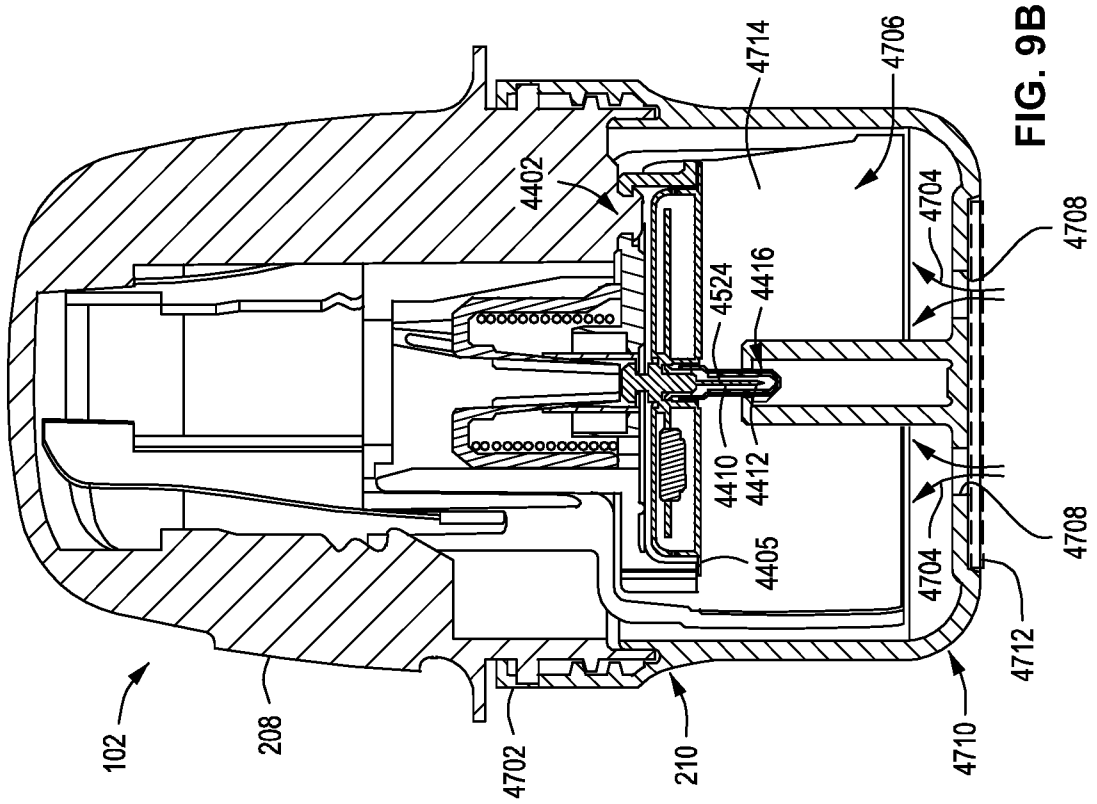

FIG. 9B

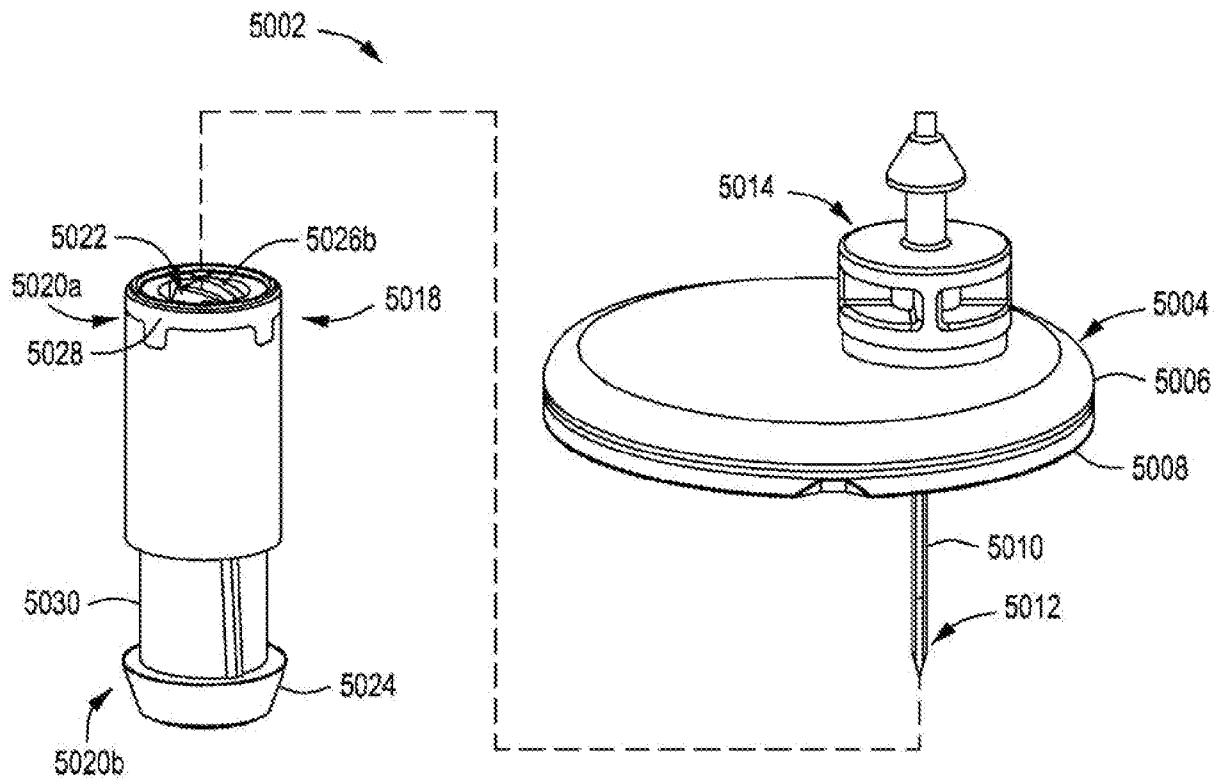

FIG. 10A

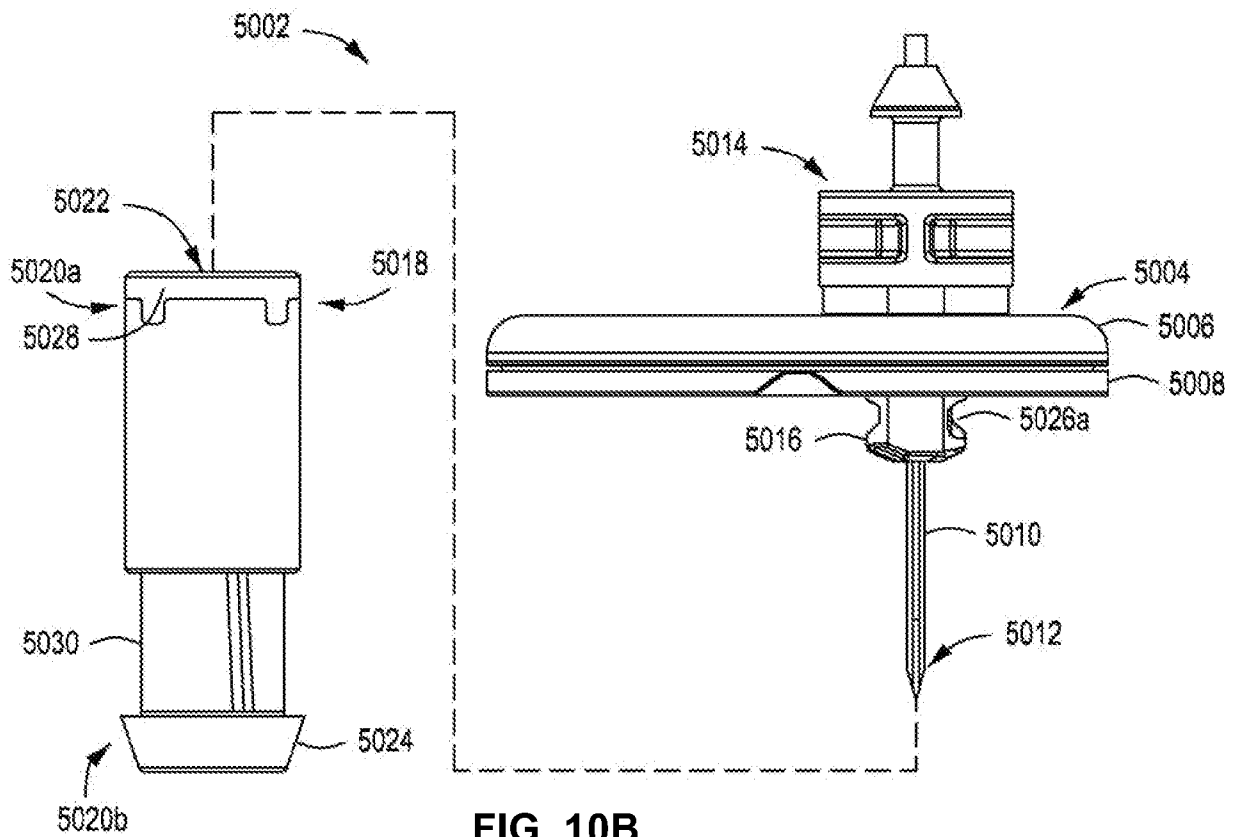

FIG. 10B

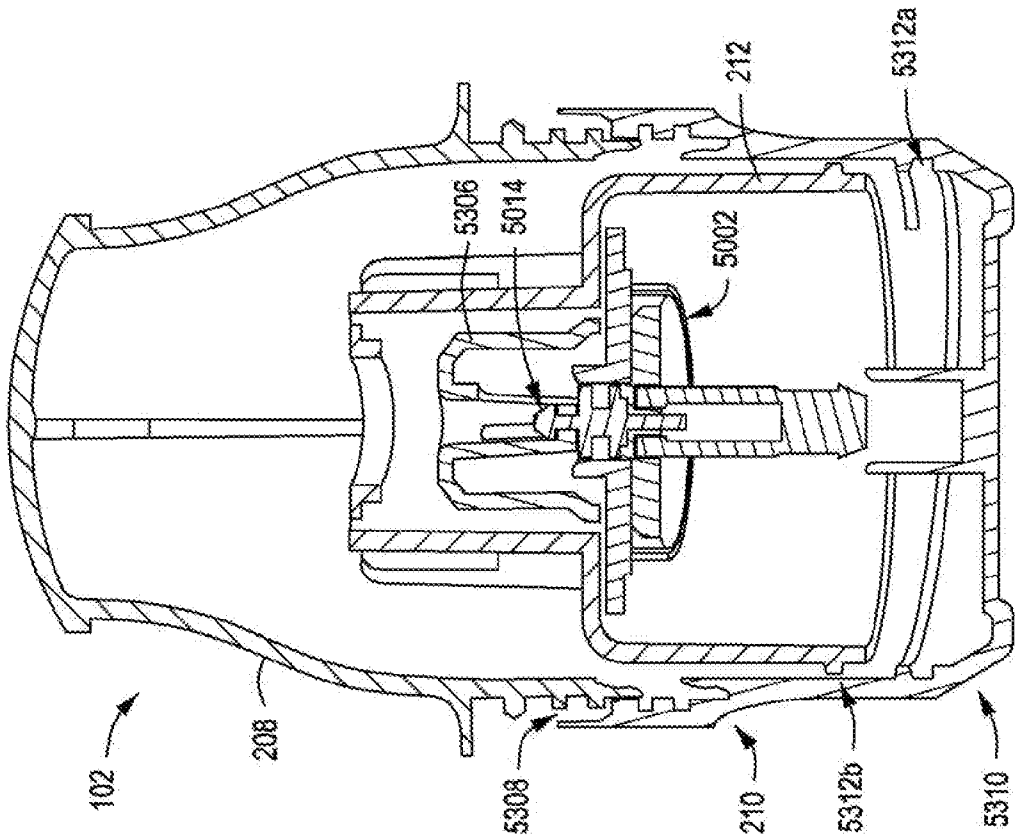

FIG. 11B

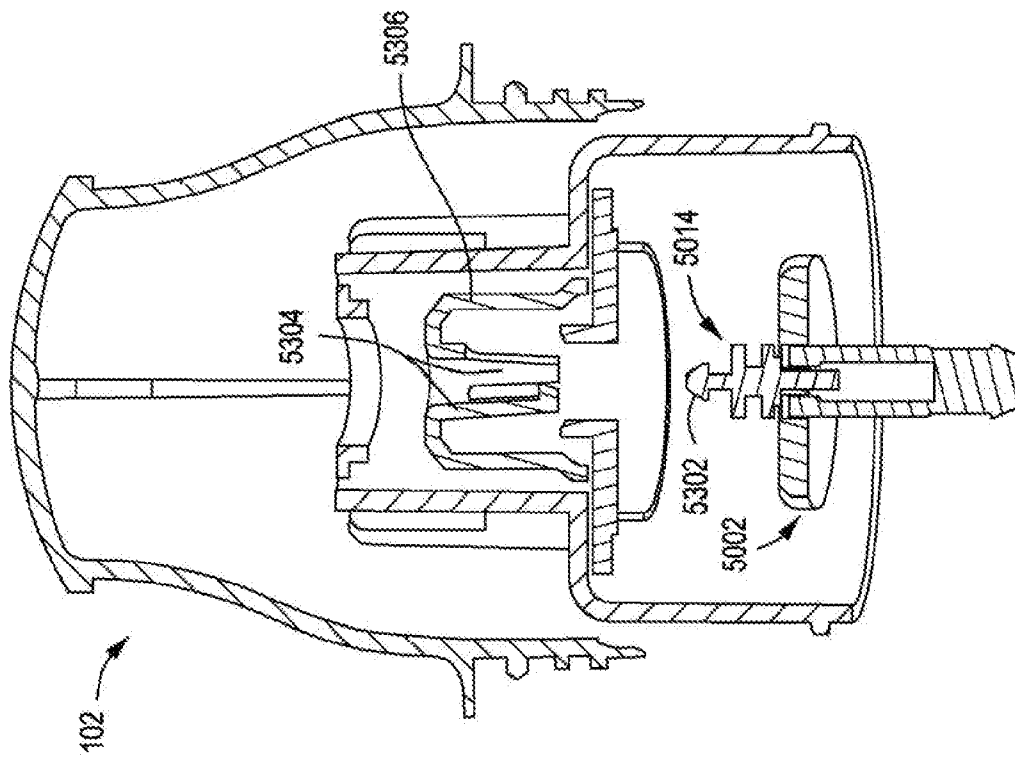

FIG. 11A

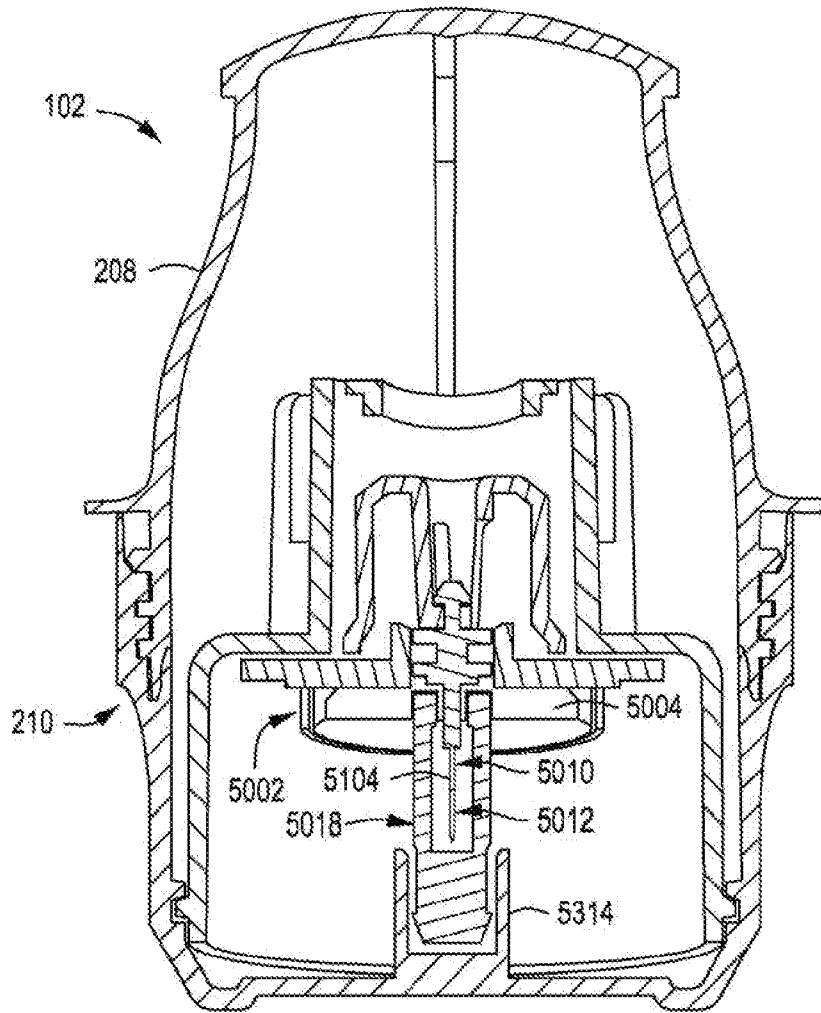

FIG. 11C

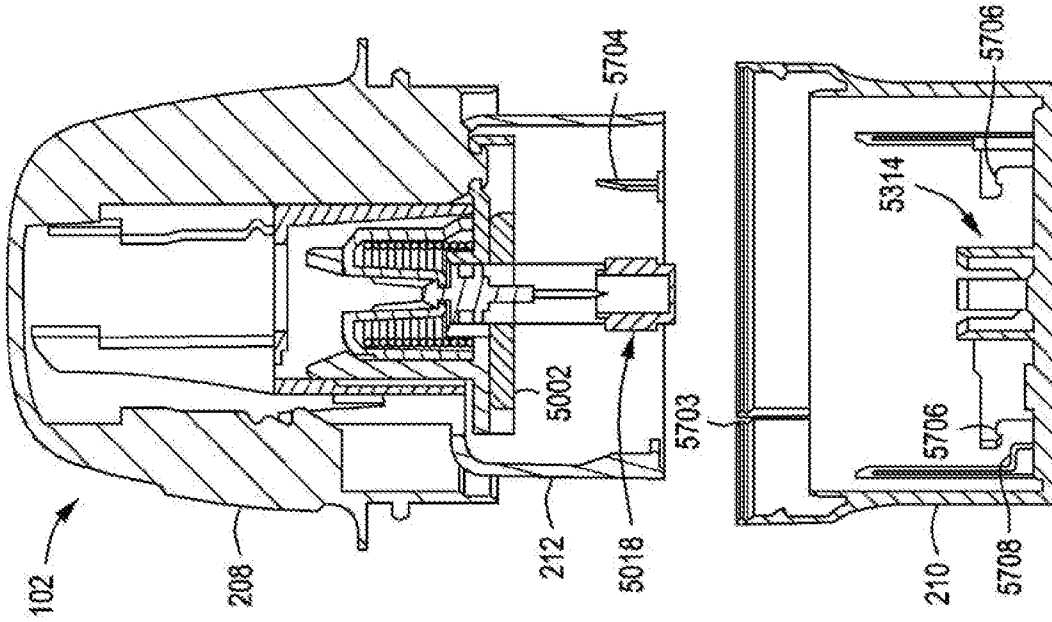

FIG. 12B

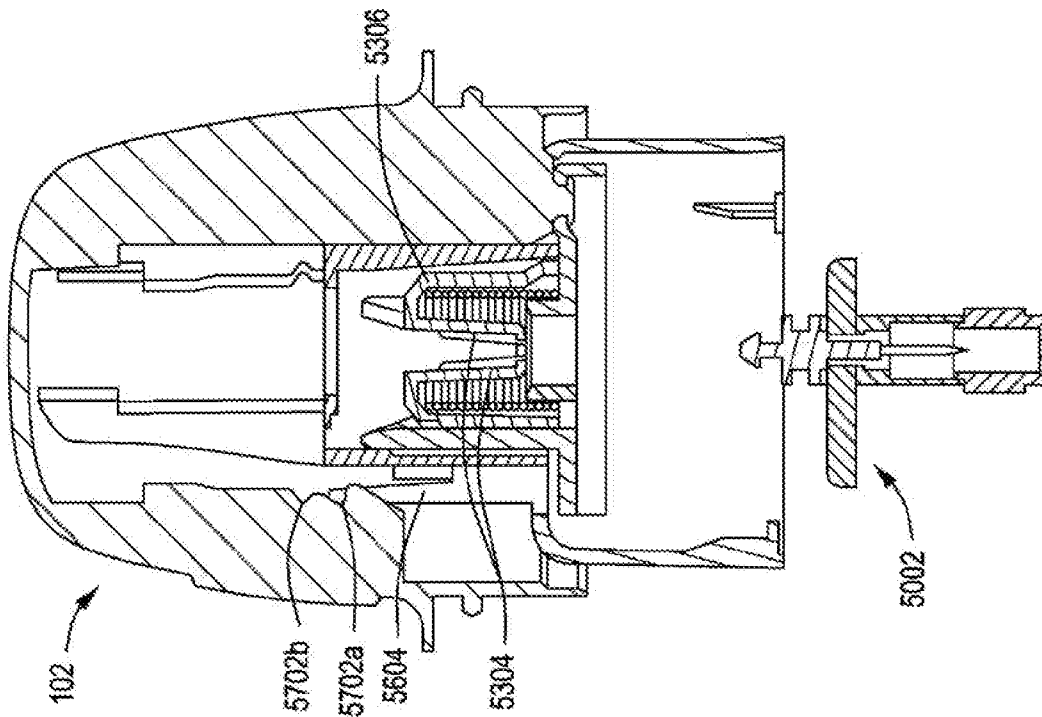

FIG. 12A

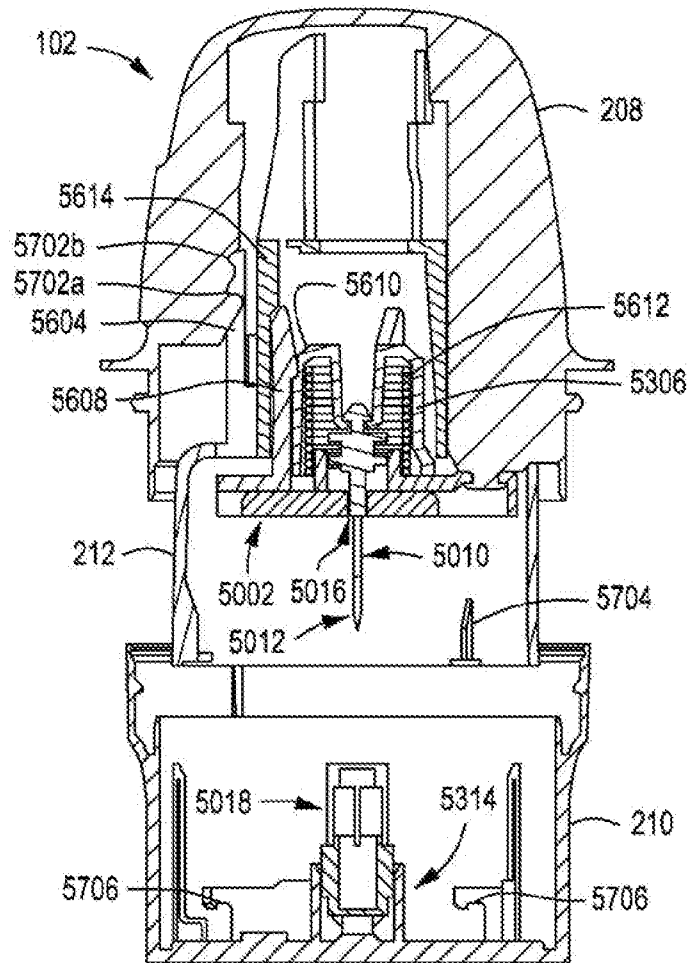

FIG. 12C



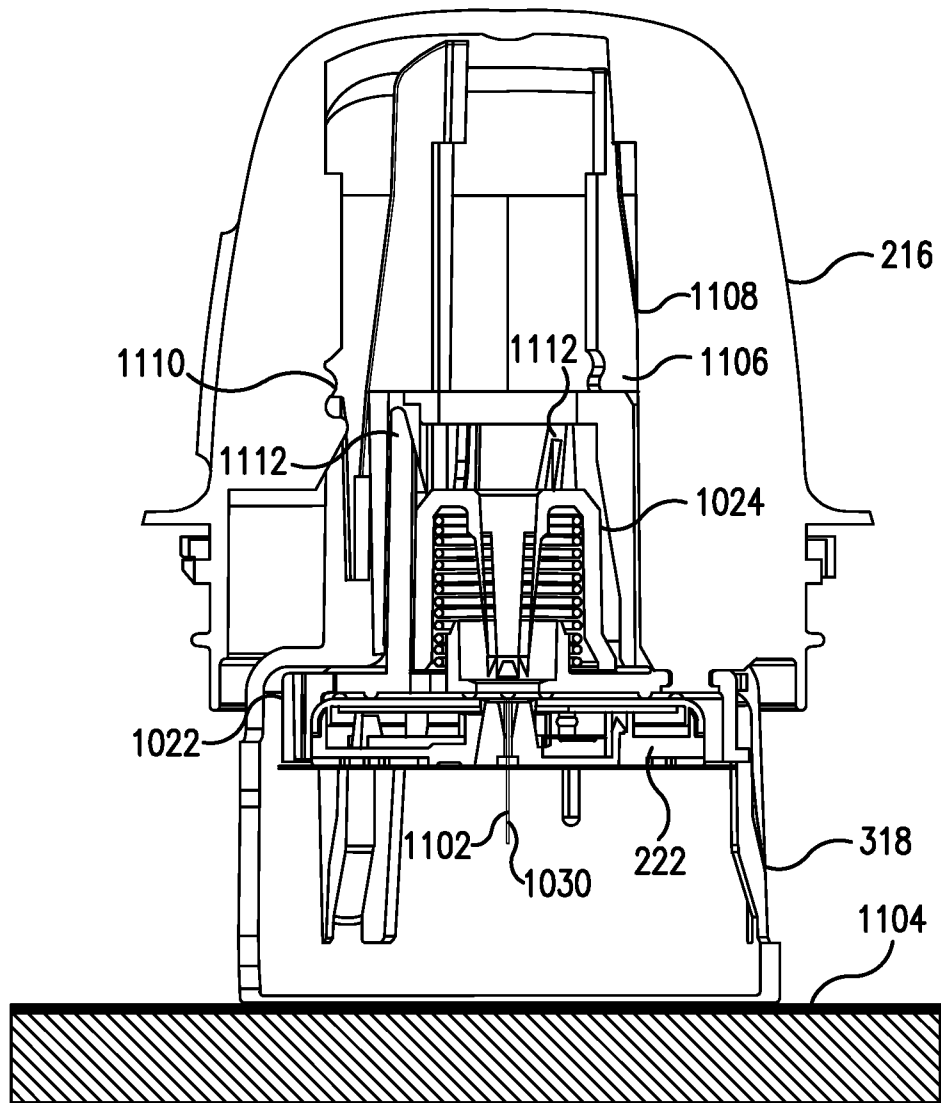
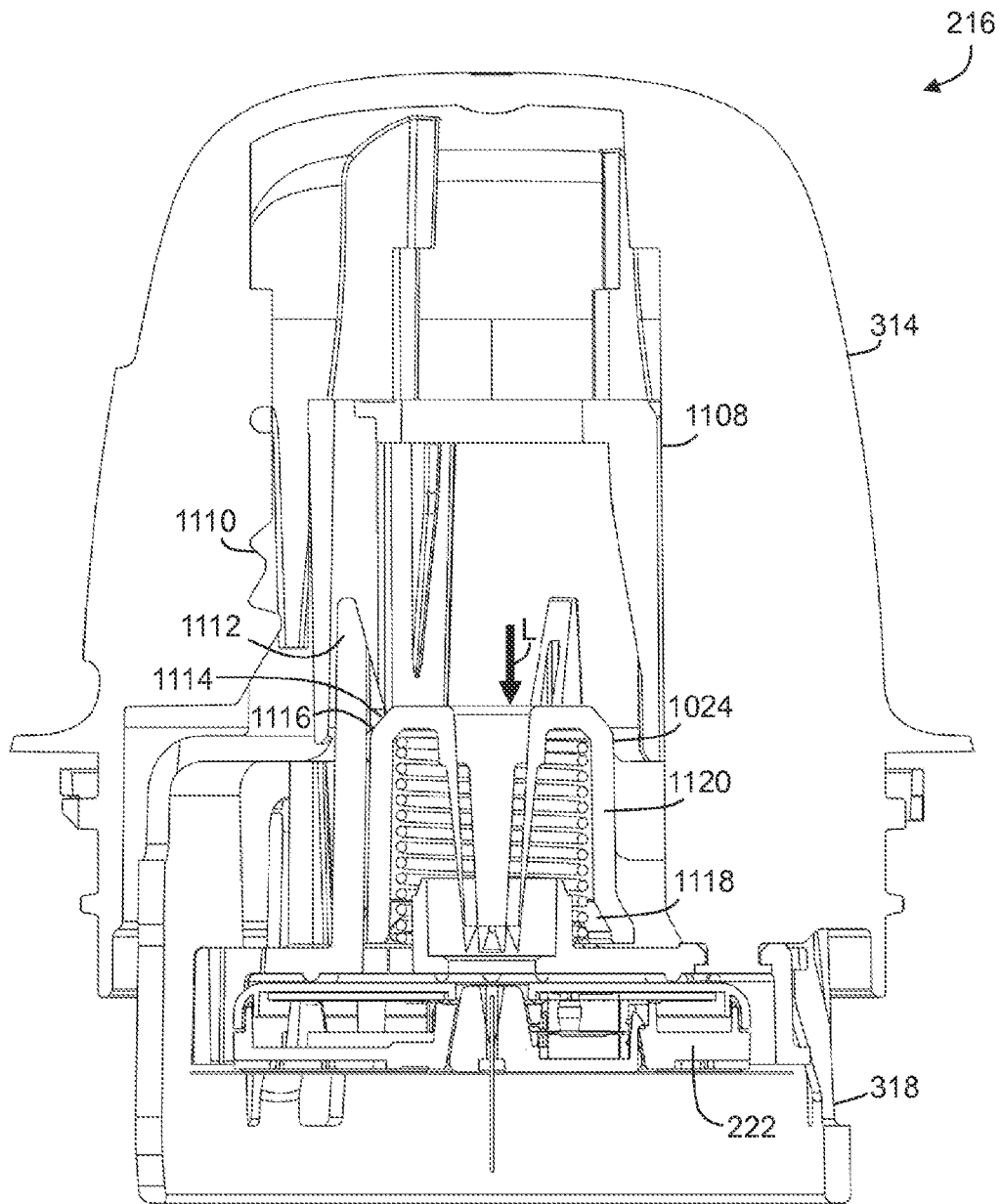
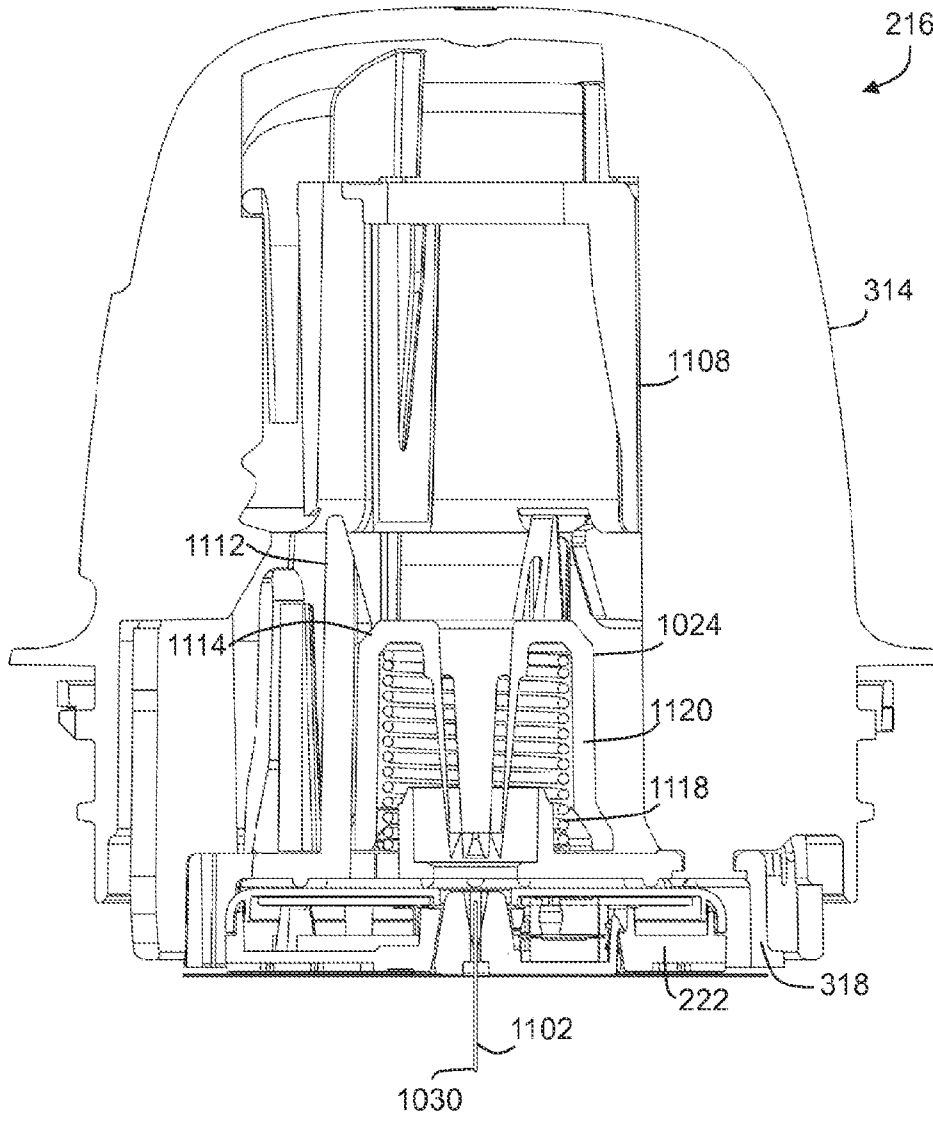

FIG. 13A



**FIG. 13B**



**FIG. 13C**

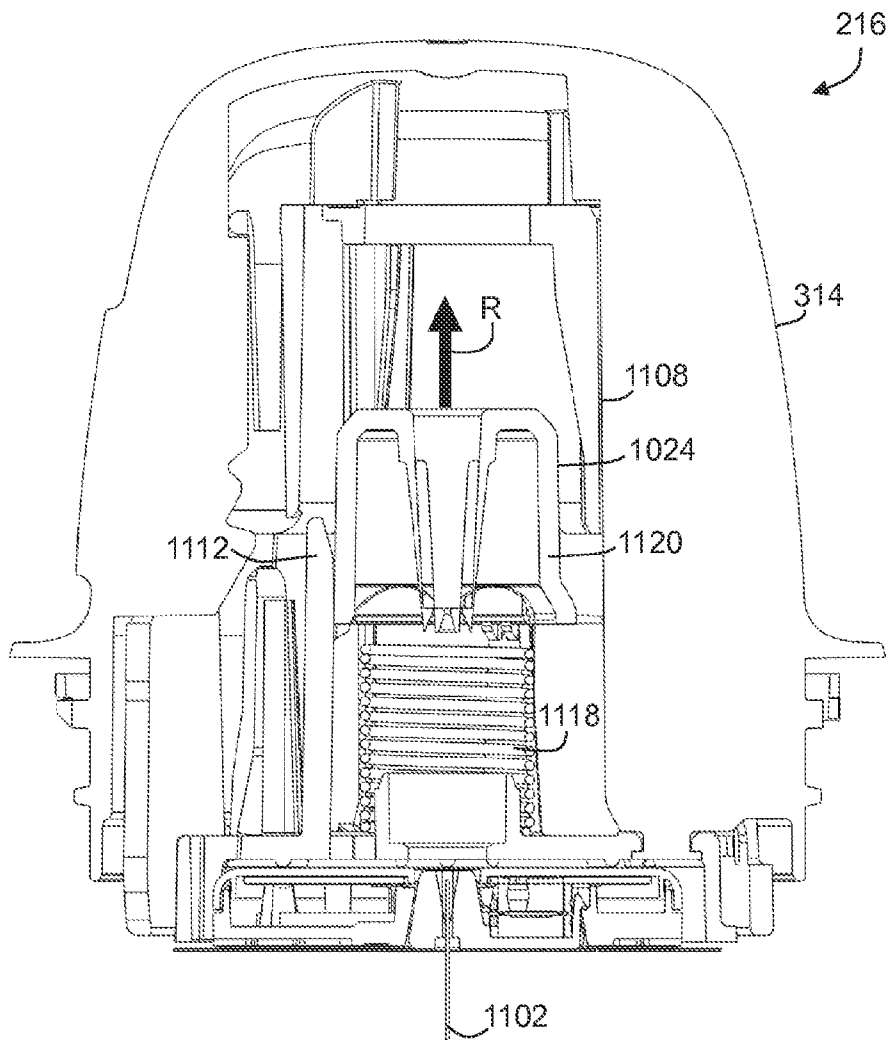

**FIG. 13D**

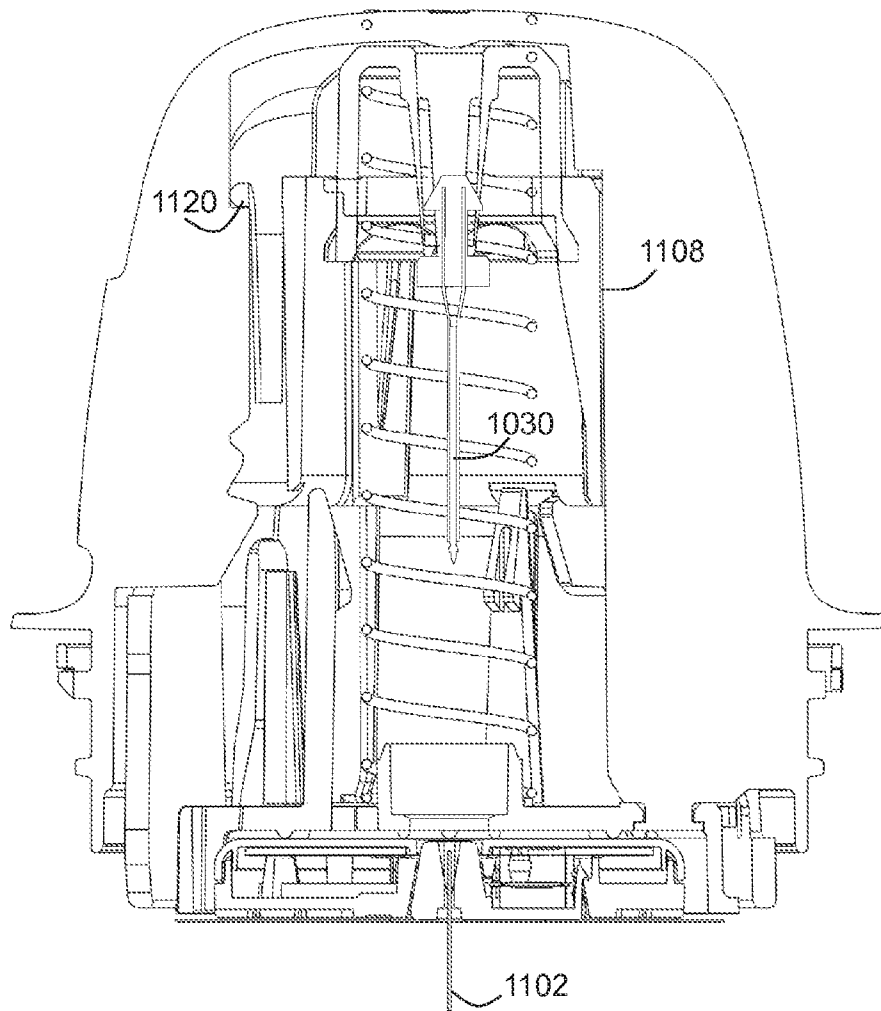

**FIG. 13E**

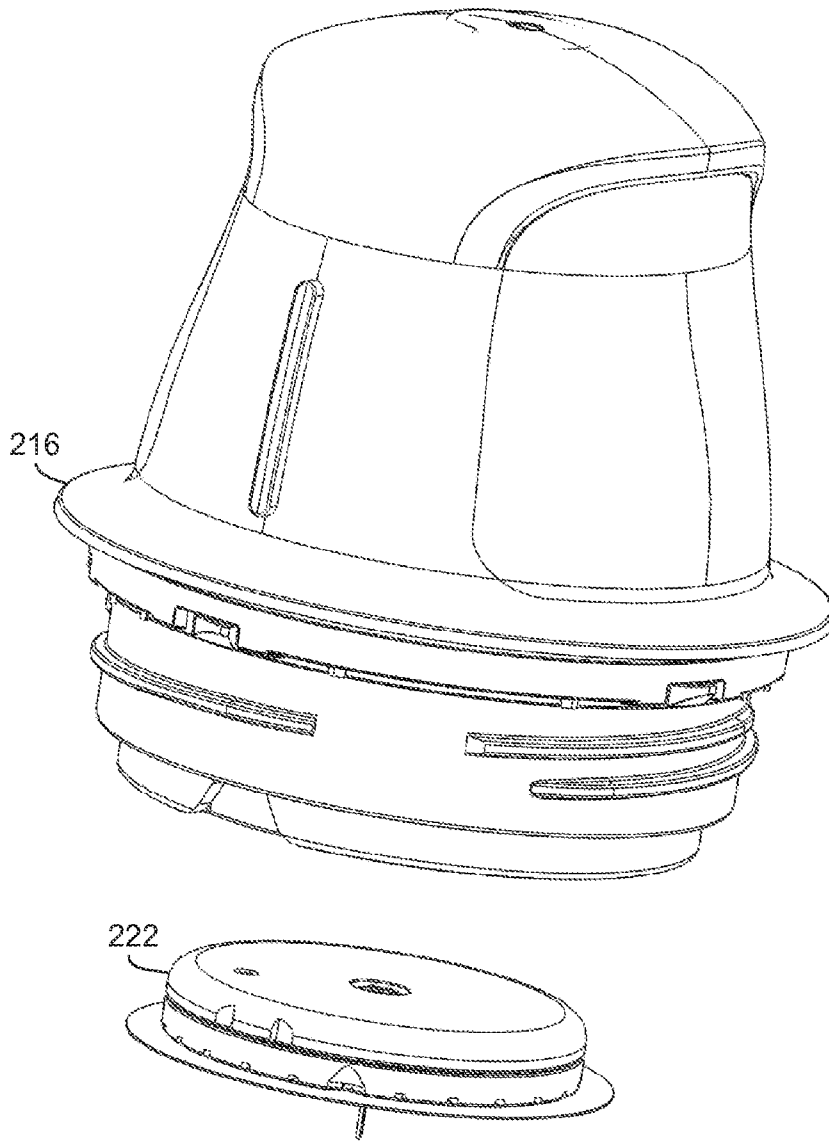

**FIG. 13F**

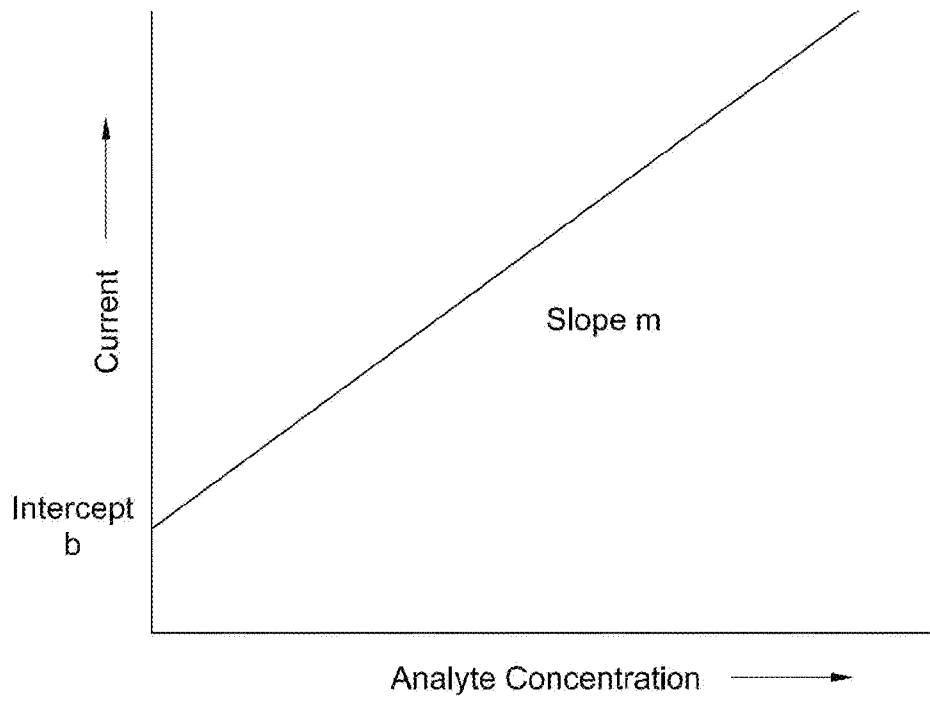

**FIG. 14**

6000

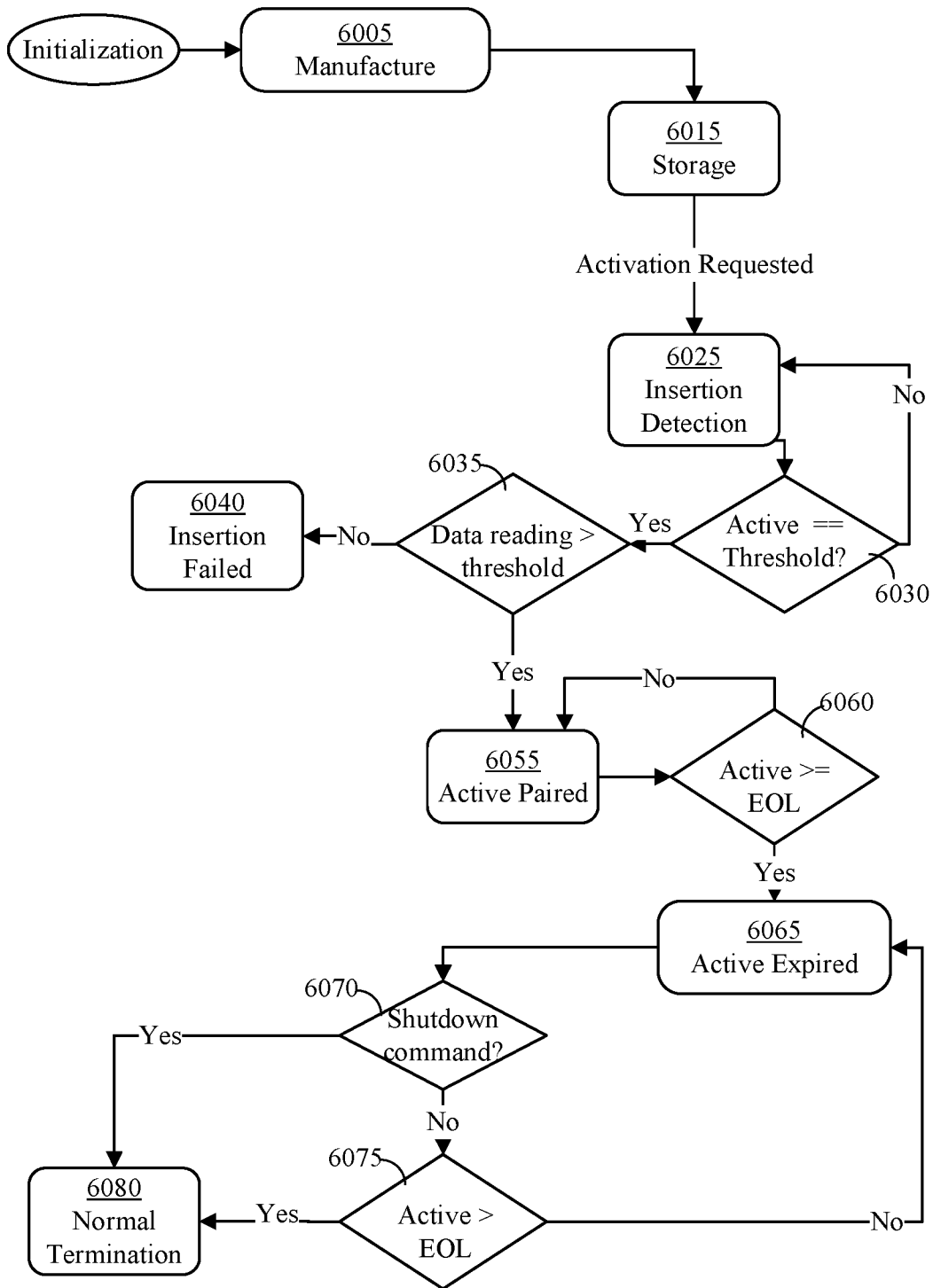
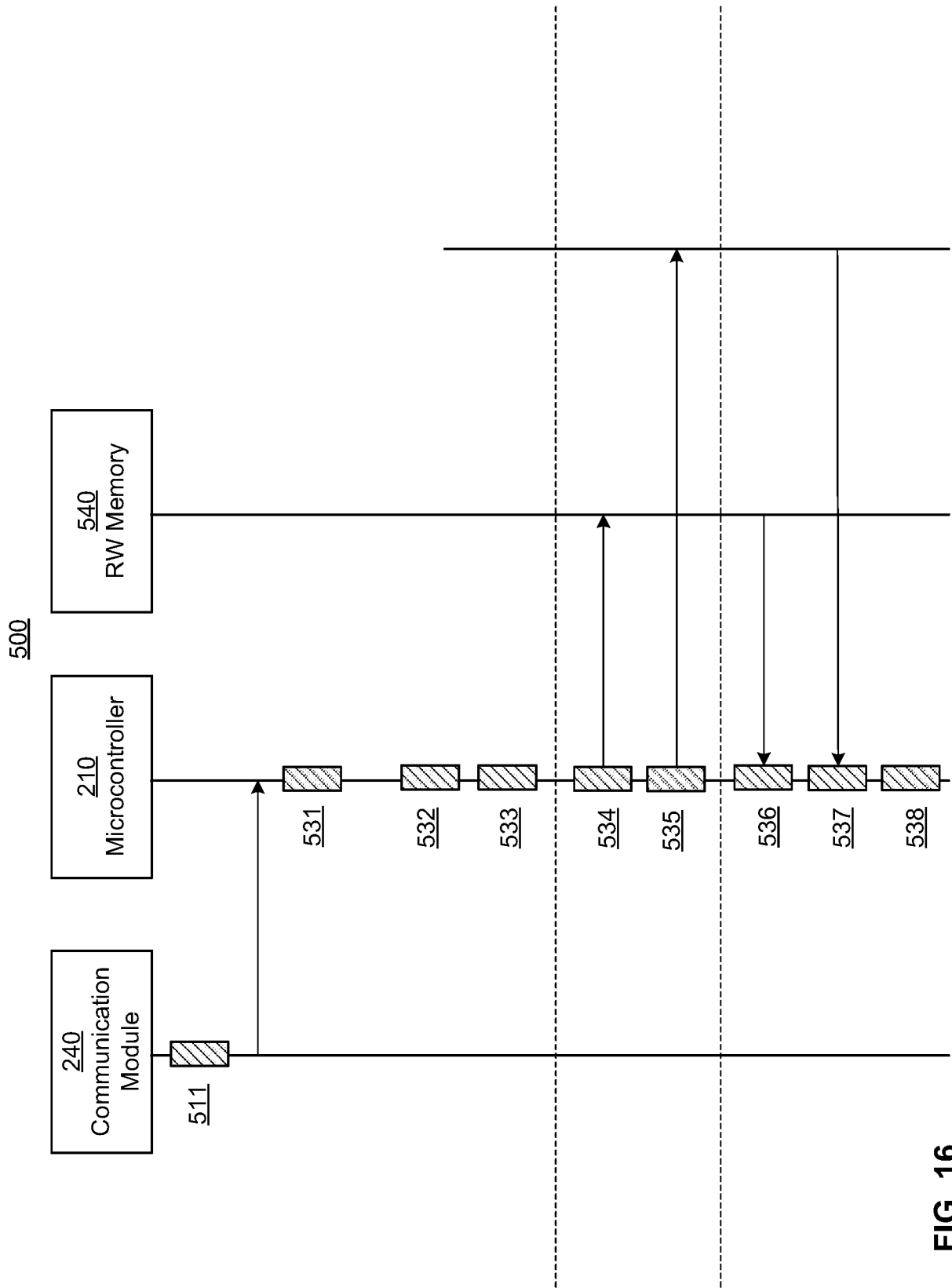

FIG. 15





**FIG. 16**

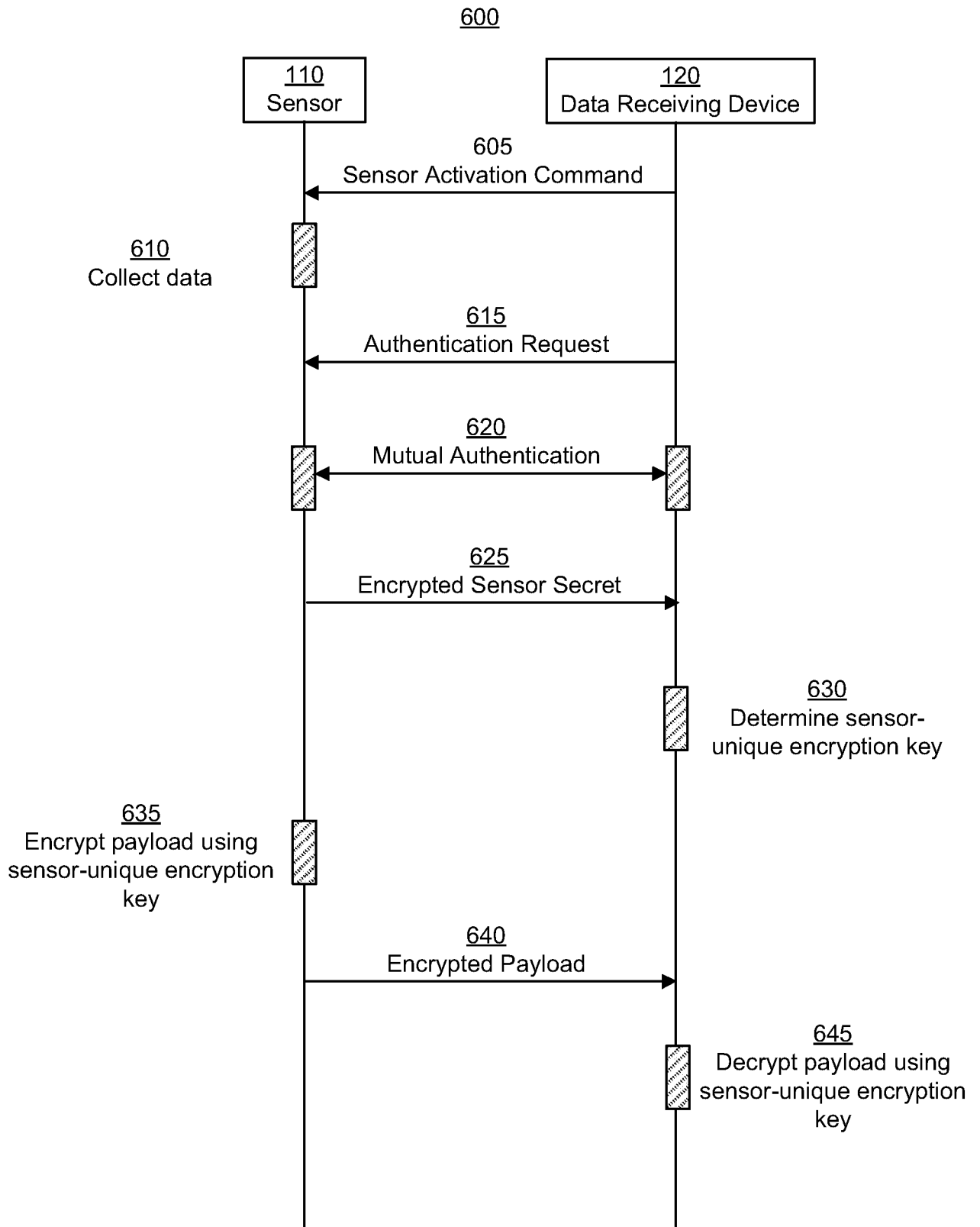

FIG. 17

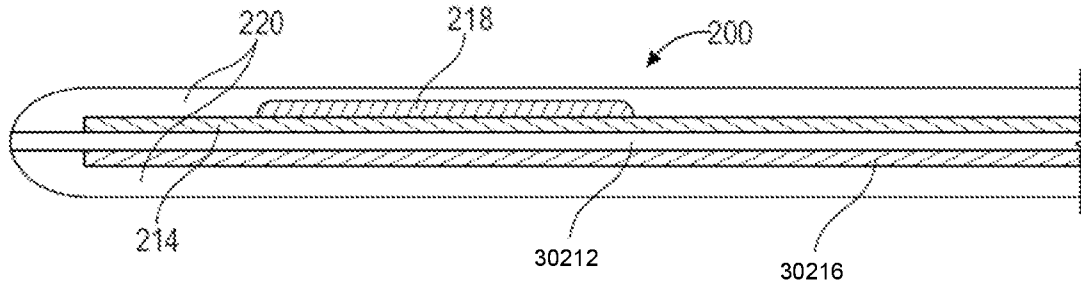

FIG. 18A

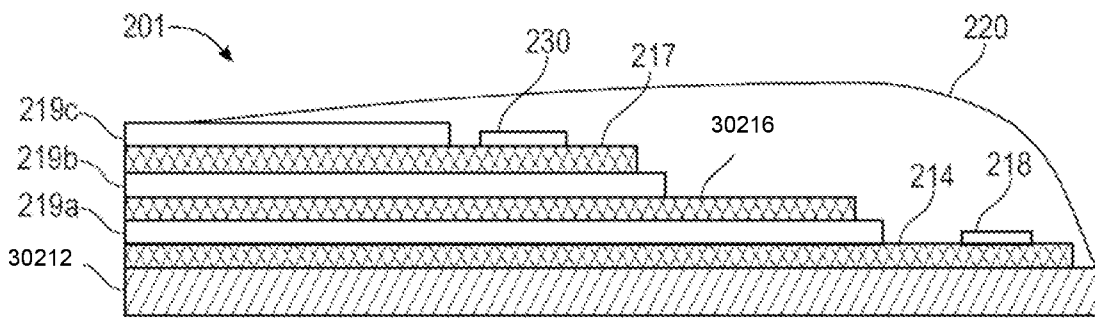

FIG. 18B

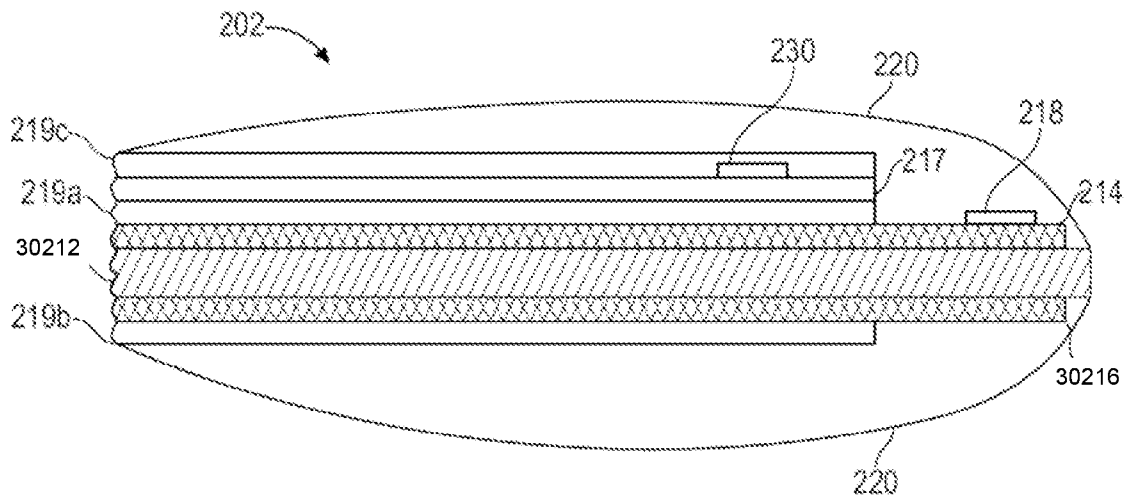

FIG. 18C

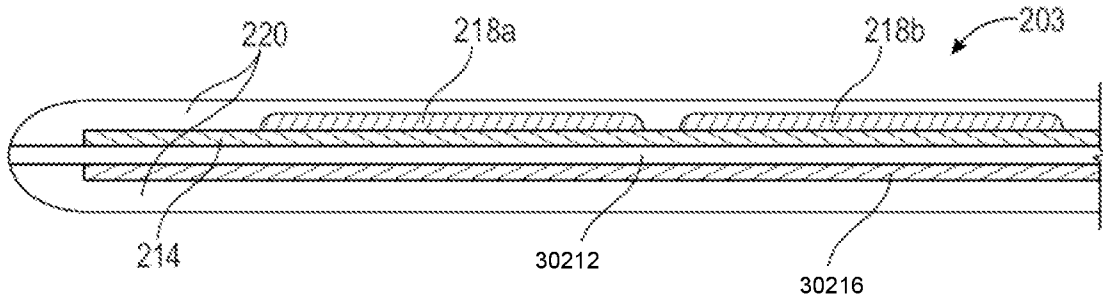

FIG. 19A

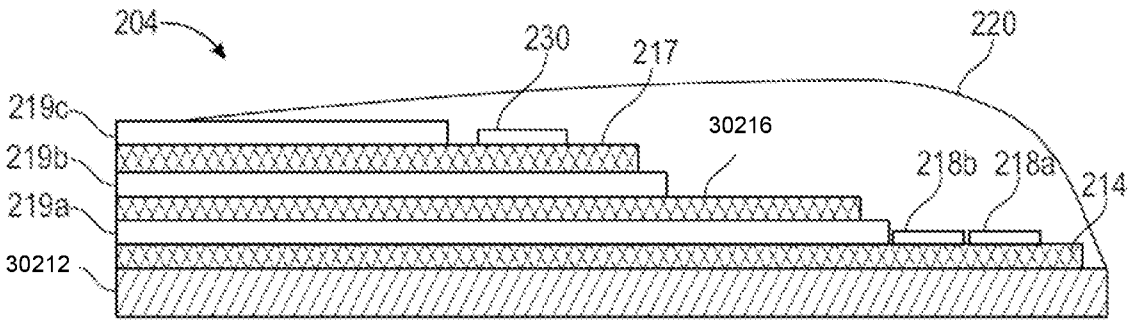

FIG. 19B

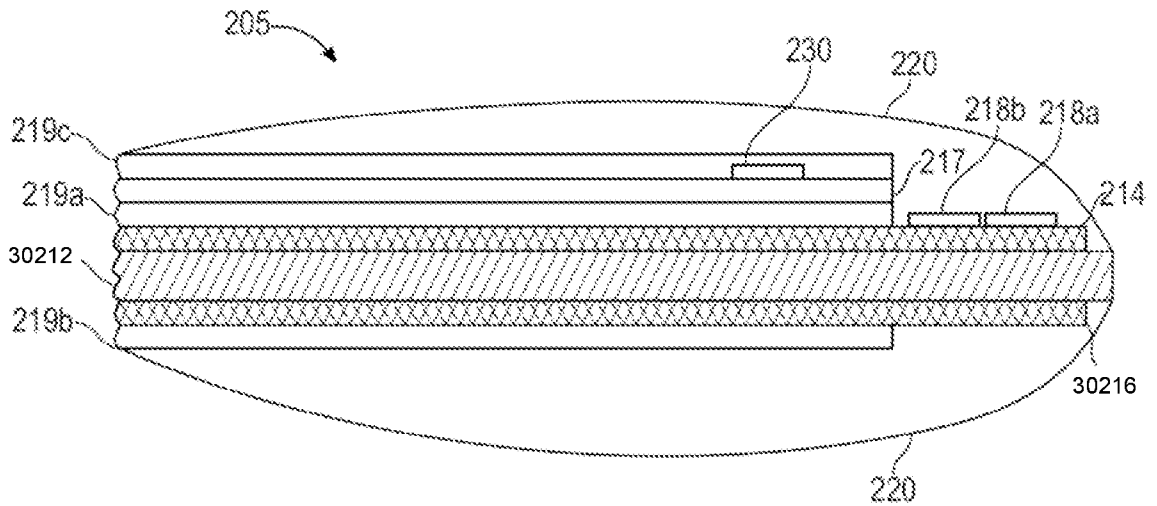

FIG. 19C

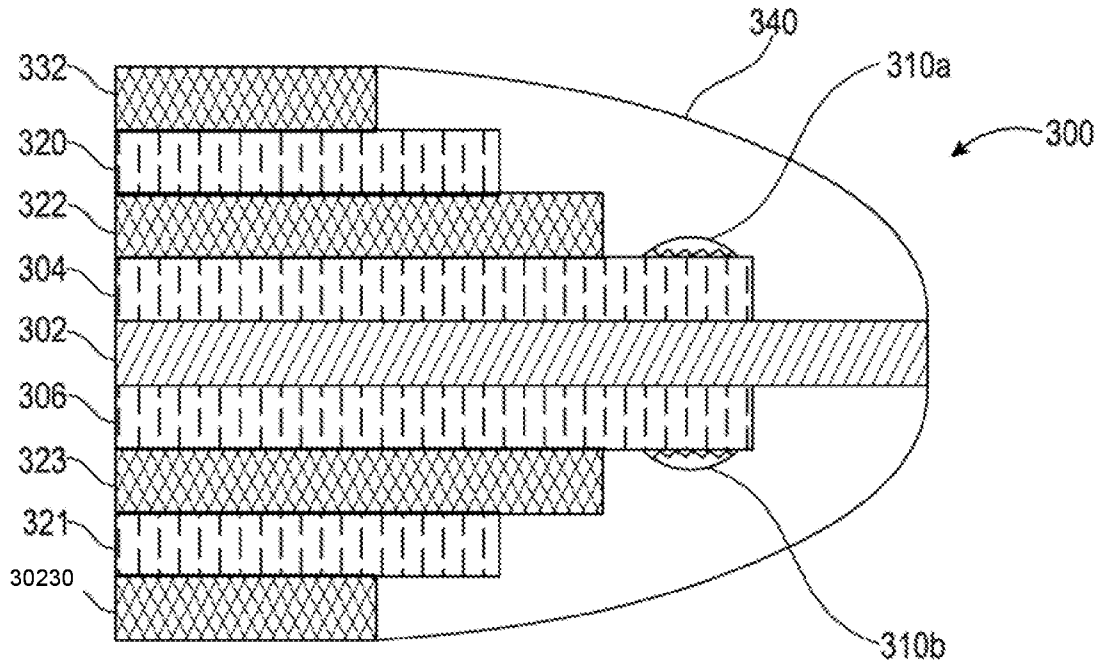

FIG. 20

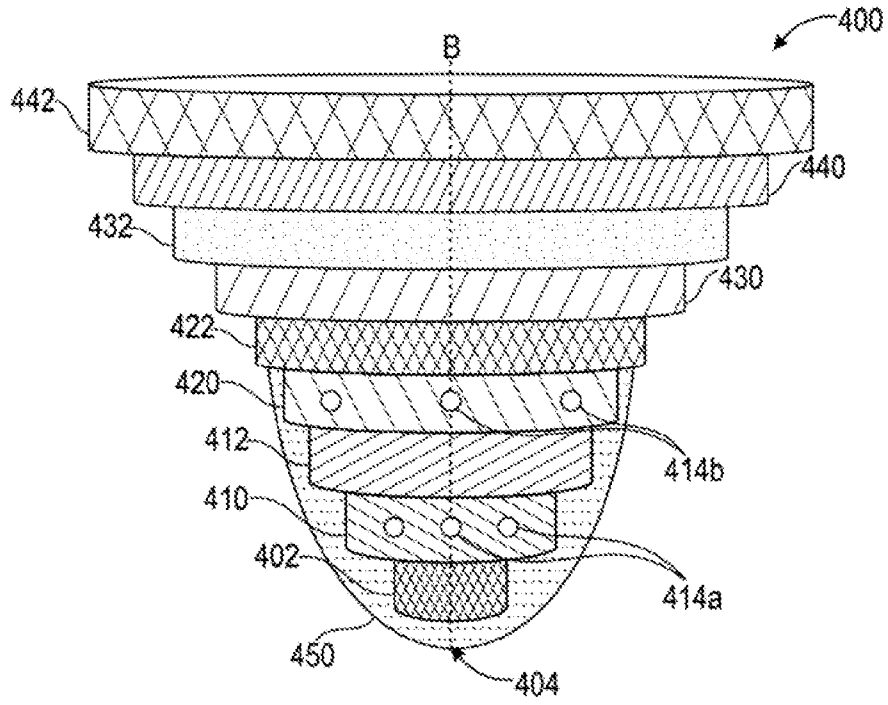

FIG. 21A

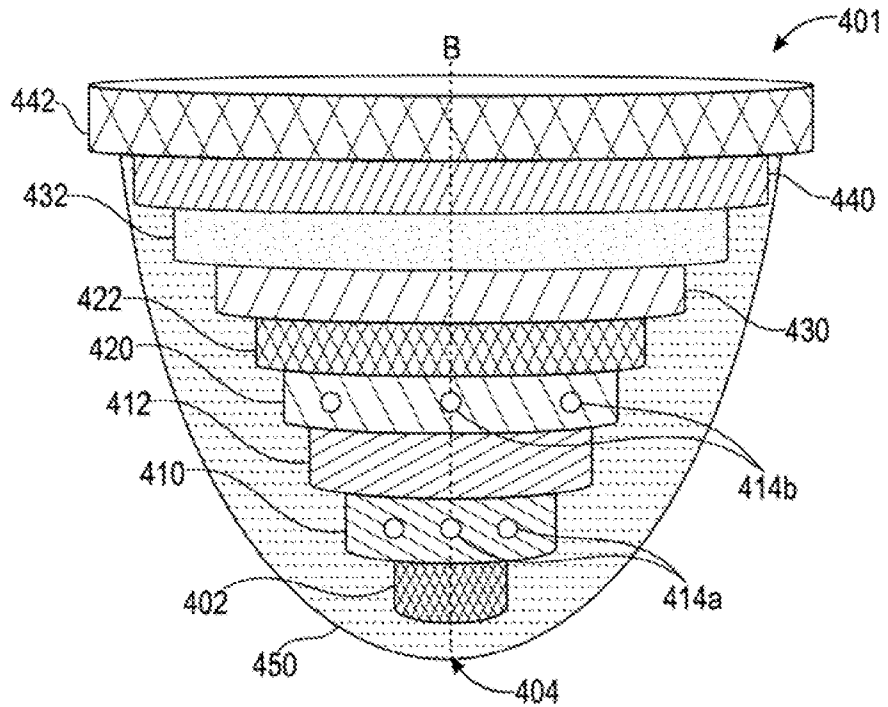

FIG. 21B

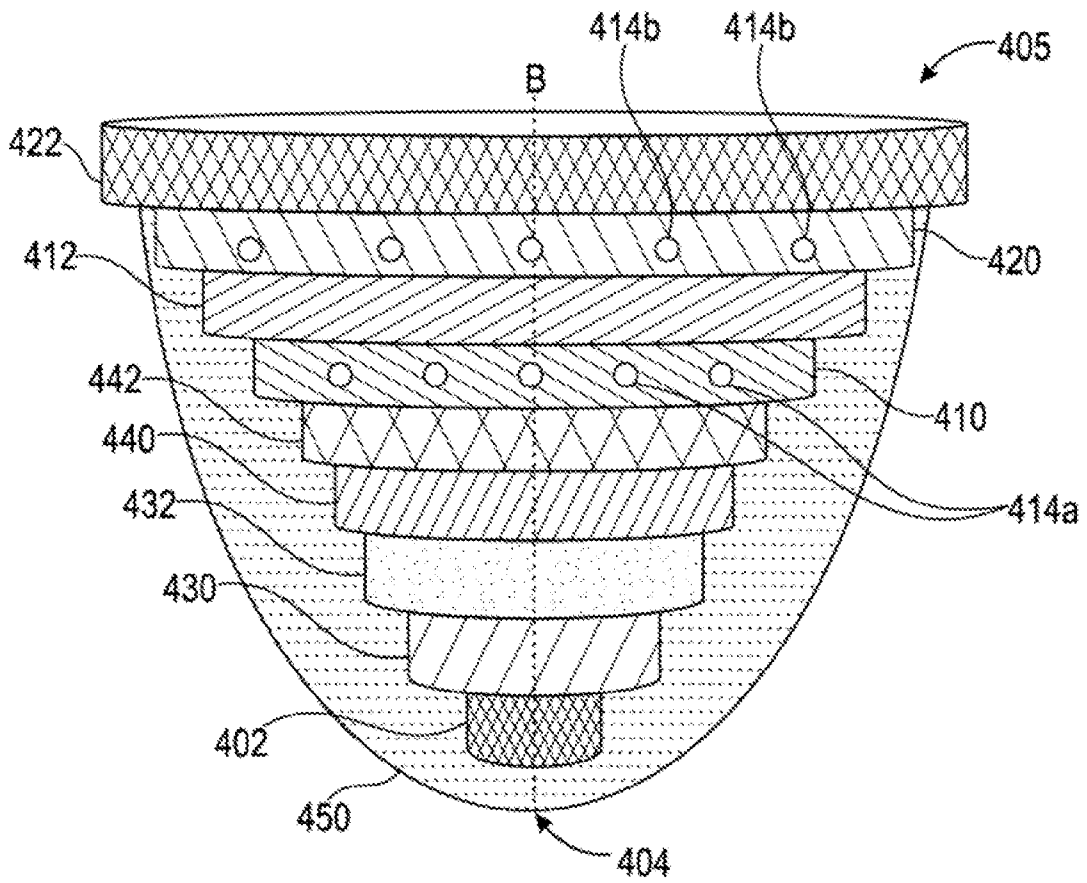

FIG. 21C

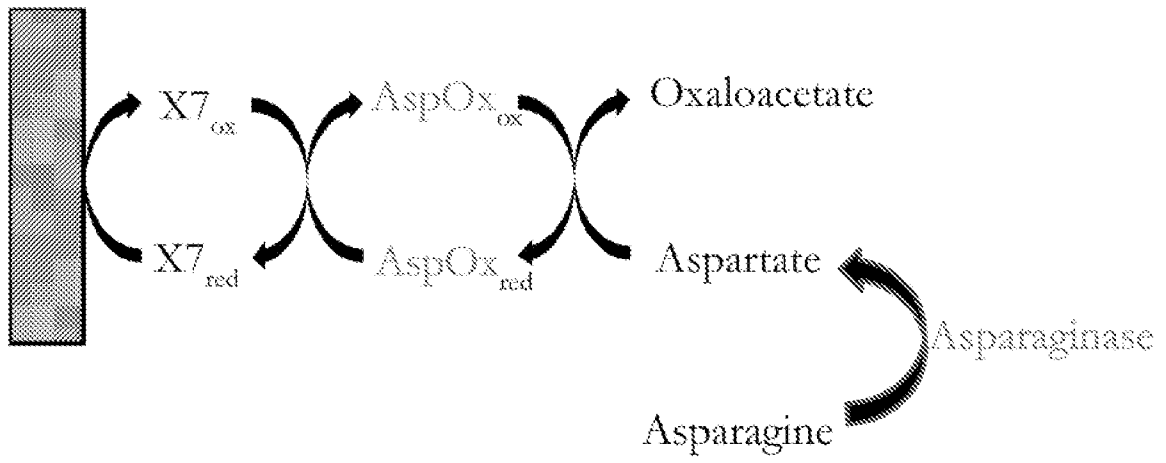

FIG. 22



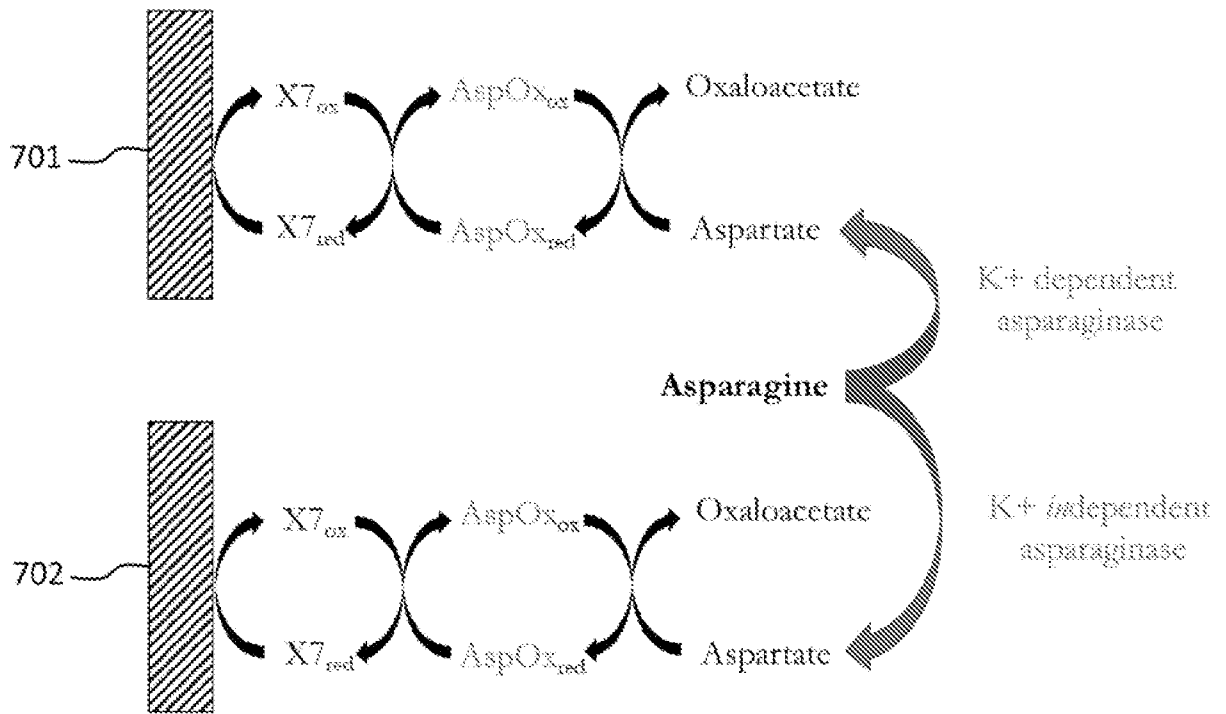

FIG. 23

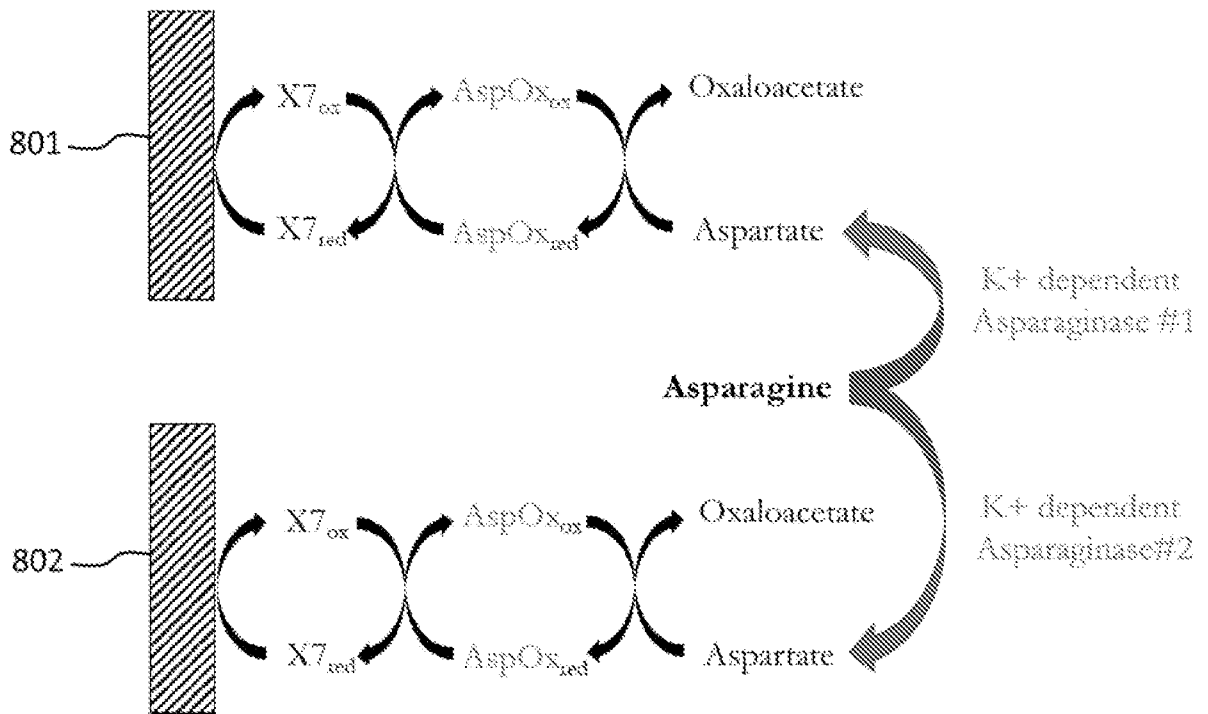

FIG. 24

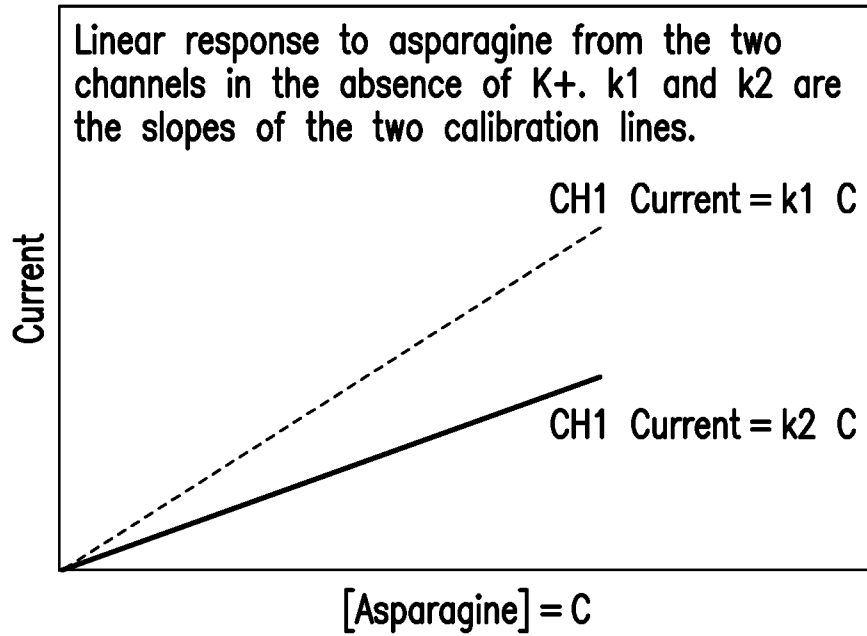

FIG. 25A

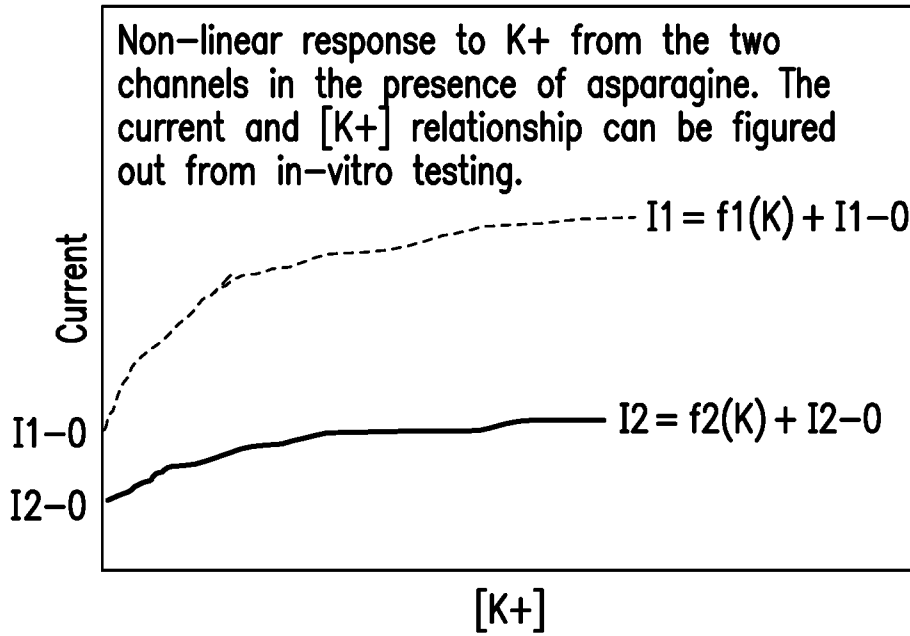

FIG. 25B

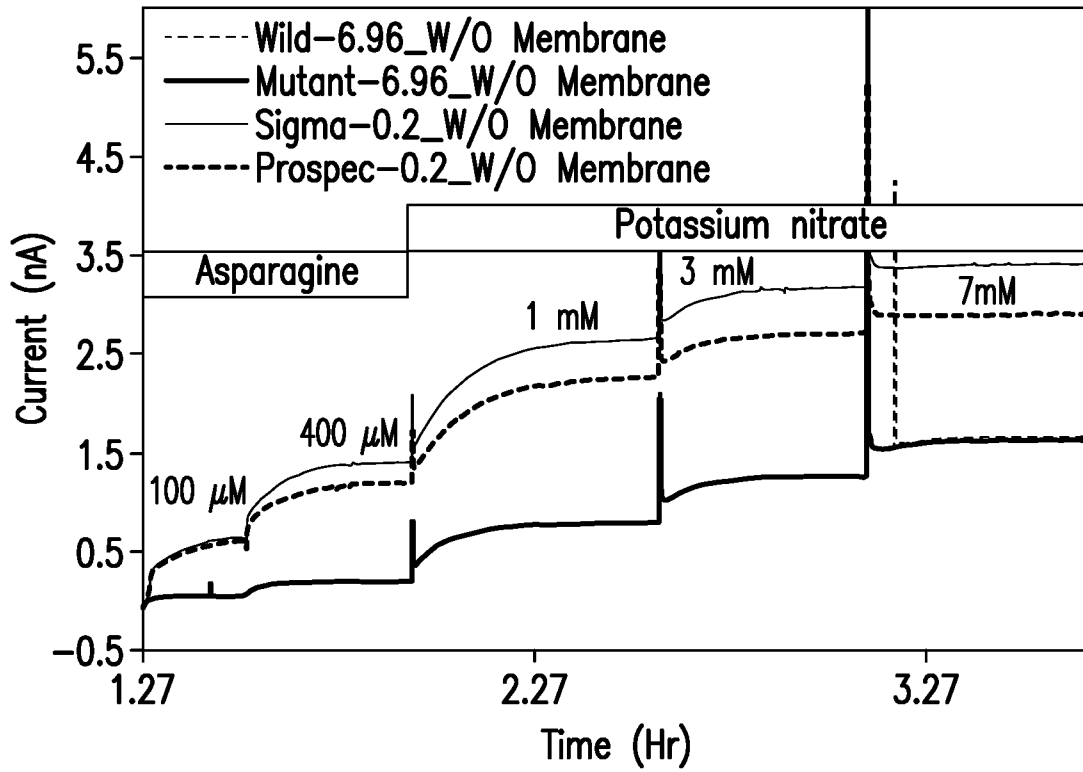

FIG. 26

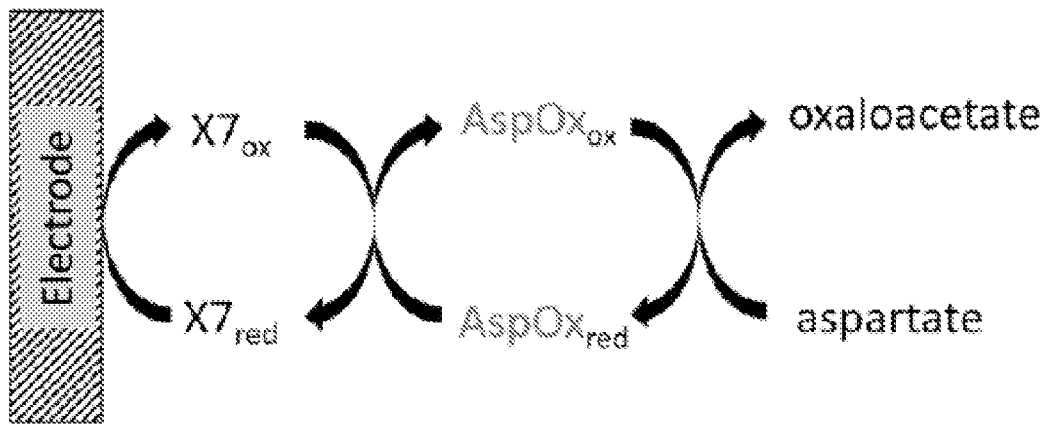

FIG. 27

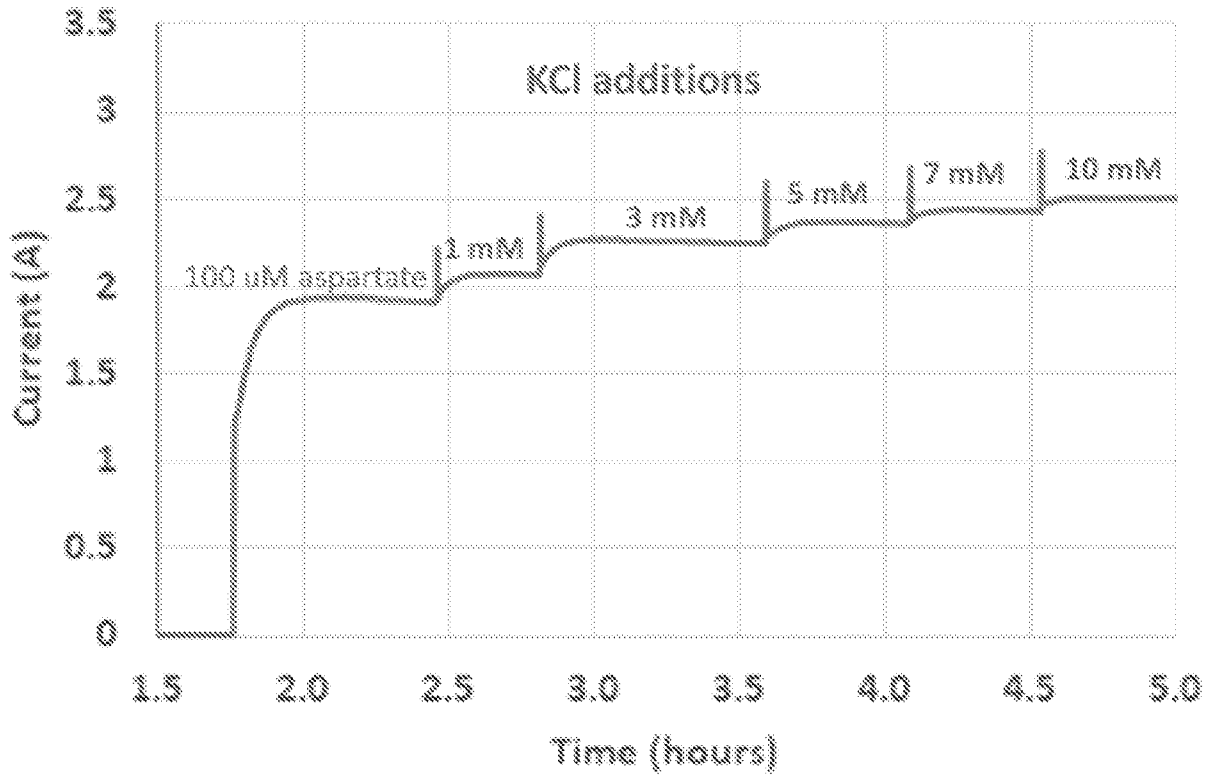

FIG. 28

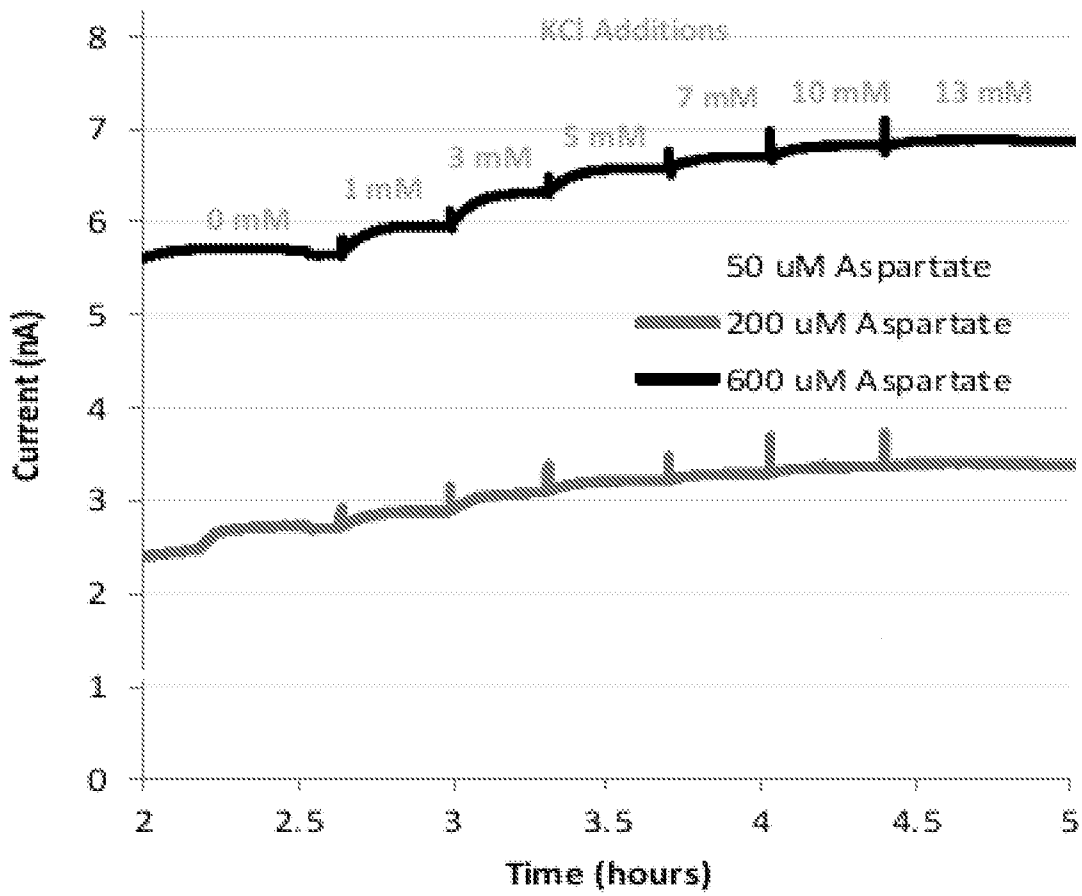

FIG. 29

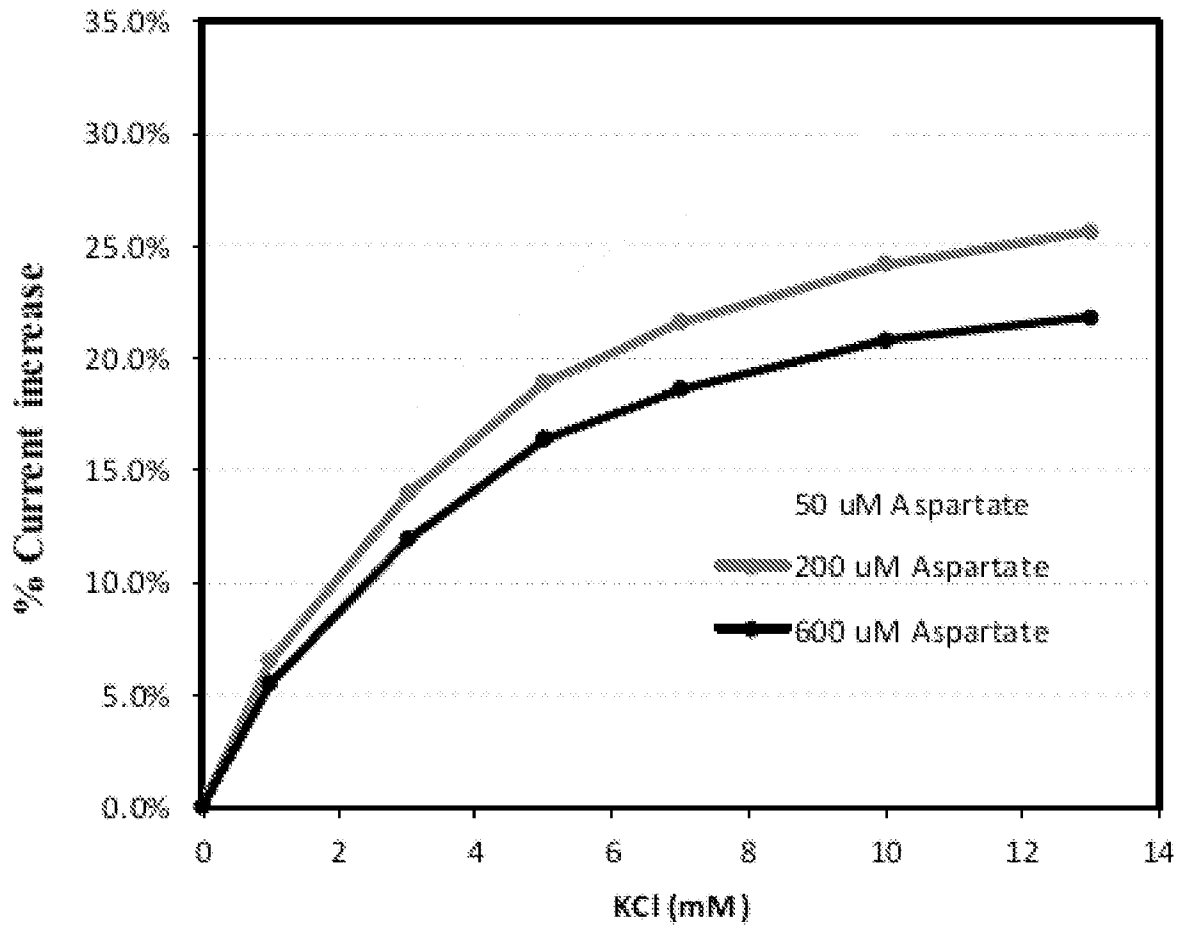

FIG. 30



# INTERNATIONAL SEARCH REPORT

International application No.  
PCT/US2021/065137

## Box No. II Observations where certain claims were found unsearchable (Continuation of item 2 of first sheet)

This international search report has not been established in respect of certain claims under Article 17(2)(a) for the following reasons:

1.  Claims Nos.: **10-20**  
because they relate to subject matter not required to be searched by this Authority, namely:  
**see FURTHER INFORMATION sheet PCT/ISA/210**
  
2.  Claims Nos.:  
because they relate to parts of the international application that do not comply with the prescribed requirements to such an extent that no meaningful international search can be carried out, specifically:
  
3.  Claims Nos.:  
because they are dependent claims and are not drafted in accordance with the second and third sentences of Rule 6.4(a).

## Box No. III Observations where unity of invention is lacking (Continuation of item 3 of first sheet)

This International Searching Authority found multiple inventions in this international application, as follows:

1.  As all required additional search fees were timely paid by the applicant, this international search report covers all searchable claims.
  
2.  As all searchable claims could be searched without effort justifying an additional fees, this Authority did not invite payment of additional fees.
  
3.  As only some of the required additional search fees were timely paid by the applicant, this international search report covers only those claims for which fees were paid, specifically claims Nos.:
  
4.  No required additional search fees were timely paid by the applicant. Consequently, this international search report is restricted to the invention first mentioned in the claims;; it is covered by claims Nos.:

### Remark on Protest

- The additional search fees were accompanied by the applicant's protest and, where applicable, the payment of a protest fee.
- The additional search fees were accompanied by the applicant's protest but the applicable protest fee was not paid within the time limit specified in the invitation.
- No protest accompanied the payment of additional search fees.

**INTERNATIONAL SEARCH REPORT**

International application No  
**PCT/US2021/065137**

**A. CLASSIFICATION OF SUBJECT MATTER**  
**INV. A61B5/145 A61B5/1486**  
**ADD.**

According to International Patent Classification (IPC) or to both national classification and IPC

**B. FIELDS SEARCHED**

Minimum documentation searched (classification system followed by classification symbols)  
**A61B**

Documentation searched other than minimum documentation to the extent that such documents are included in the fields searched

Electronic data base consulted during the international search (name of data base and, where practicable, search terms used)  
**EPO-Internal, WPI Data**

**C. DOCUMENTS CONSIDERED TO BE RELEVANT**

Category*	Citation of document, with indication, where appropriate, of the relevant passages	Relevant to claim No.
<b>X</b>	<b>US 2009/131769 A1 (LEACH JACOB S [US] ET AL) 21 May 2009 (2009-05-21)</b>	<b>1, 2</b>
<b>A</b>	<b>paragraphs [0025], [0112], [0253], [0340]</b>	<b>3-9</b>
	-----	
<b>A</b>	<b>US 2006/079740 A1 (SILVER JAMES H [US] ET AL) 13 April 2006 (2006-04-13)</b>	<b>1-9</b>
	<b>paragraph [0354]</b>	
	-----	

Further documents are listed in the continuation of Box C.

See patent family annex.

\* Special categories of cited documents :

- "A" document defining the general state of the art which is not considered to be of particular relevance
- "E" earlier application or patent but published on or after the international filing date
- "L" document which may throw doubts on priority claim(s) or which is cited to establish the publication date of another citation or other special reason (as specified)
- "O" document referring to an oral disclosure, use, exhibition or other means
- "P" document published prior to the international filing date but later than the priority date claimed

- "T" later document published after the international filing date or priority date and not in conflict with the application but cited to understand the principle or theory underlying the invention
- "X" document of particular relevance; the claimed invention cannot be considered novel or cannot be considered to involve an inventive step when the document is taken alone
- "Y" document of particular relevance; the claimed invention cannot be considered to involve an inventive step when the document is combined with one or more other such documents, such combination being obvious to a person skilled in the art
- "&" document member of the same patent family

Date of the actual completion of the international search  
  
**21 April 2022**

Date of mailing of the international search report  
  
**29/04/2022**

Name and mailing address of the ISA/  
 European Patent Office, P.B. 5818 Patentlaan 2  
 NL - 2280 HV Rijswijk  
 Tel. (+31-70) 340-2040,  
 Fax: (+31-70) 340-3016

Authorized officer  
  
**Chau, Thoi Dai**

# INTERNATIONAL SEARCH REPORT

Information on patent family members

International application No

**PCT/US2021/065137**

Patent document cited in search report	Publication date	Patent family member(s)	Publication date
<b>US 2009131769 A1</b>	<b>21-05-2009</b>	<b>US 2009131769 A1</b>	<b>21-05-2009</b>
		<b>US 2014088391 A1</b>	<b>27-03-2014</b>
-----			
<b>US 2006079740 A1</b>	<b>13-04-2006</b>	<b>US 2006079740 A1</b>	<b>13-04-2006</b>
		<b>WO 2007058872 A2</b>	<b>24-05-2007</b>
-----			

## FURTHER INFORMATION CONTINUED FROM PCT/ISA/ 210

Continuation of Box II.1

Claims Nos.: 10-20

Claim 10 relates to a method for treatment of the human or animal body by surgery, due to the implicit and prerequisite step of implanting the sensor in a subject (i.e. encompassed in the broad meaning of "using the analyte sensor"; see also par. [0354]); and since there is no restriction regarding the depth or the organ involved in the implantation of the sensor in a subject, this step is considered as involving substantial health risk even when carried out by trained physicians. Claims 11-20 relate to a method for treatment of the human or animal body by surgery, due to "the analyte sensor is implanted in a subject" recited in claim 20 (i.e. claims 11-19 encompass this step), which involves substantial health risk even when carried out by trained physicians. This Authority is not required to search the present application with respect to the aforementioned claims (Article 17(2)(b) PCT and Rule 39.1(iv) PCT). Consequently, no International Search Report and no Written Opinion (Rule 67.1 PCT in combination with Rule 43bis.1(b) PCT) have been established with respect to them.