

S. L. SIMPSON.
SPRING BED.

(Application filed Mar. 8, 1901.)

(No Model.)

2 Sheets—Sheet 1.

Fig. 1.

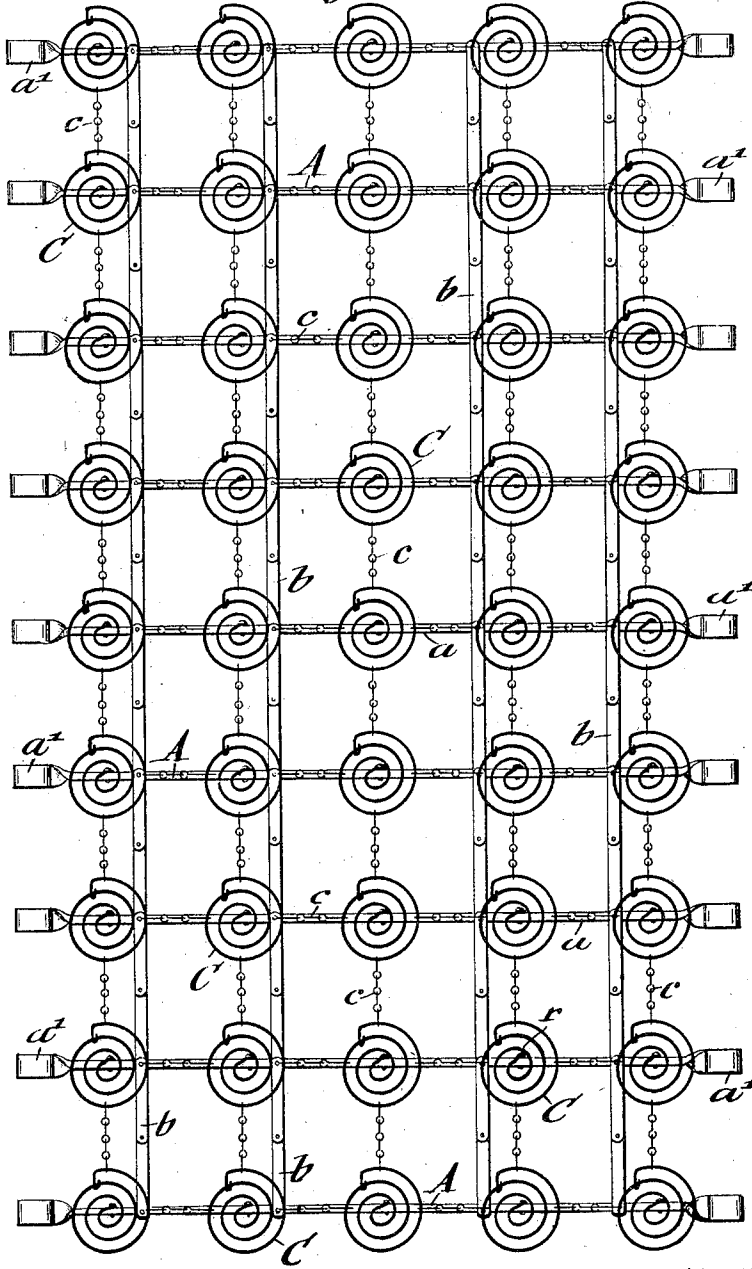

WITNESSES:

Walter Wallstein

Joseph H. Niles.

INVENTOR

Simon L. Simpson,

BY

Greene Wake

ATTORNEYS

S. L. SIMPSON.
SPRING BED.

(Application filed Mar. 8, 1901.)

(No Model.)

2 Sheets—Sheet 2.

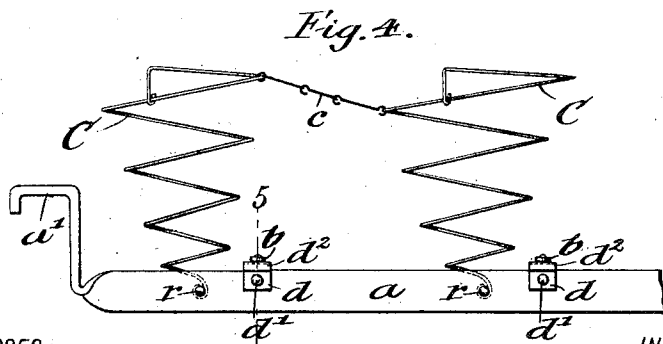
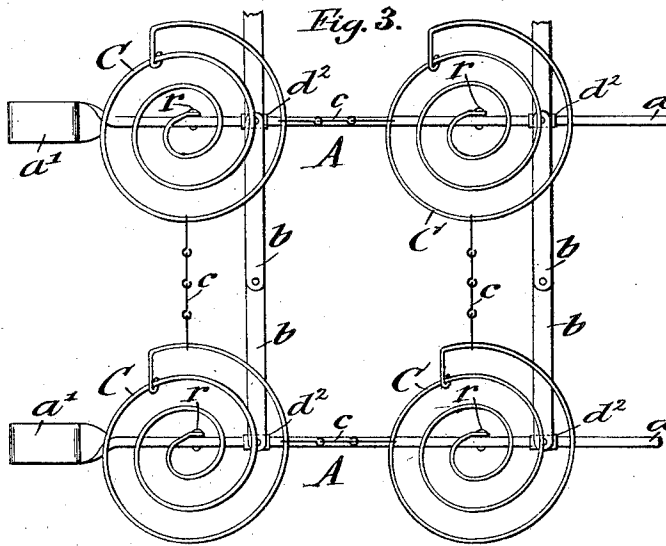
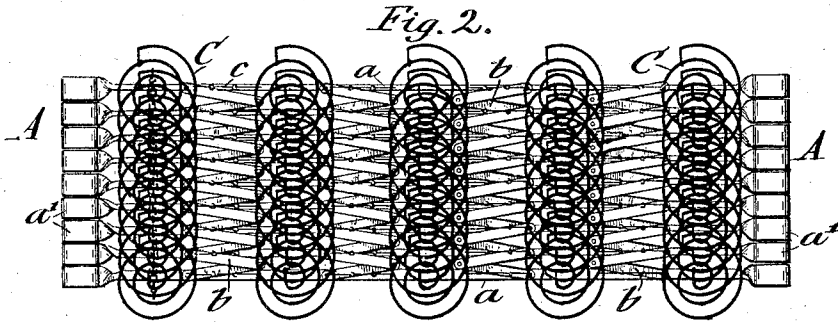

WITNESSES:
Walter Wassheim

Joseph H. Niles

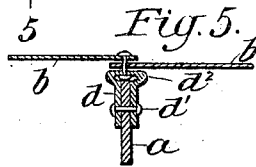

INVENTOR
Simon L. Simpson,
BY *Looney & Wable*
ATTORNEYS

UNITED STATES PATENT OFFICE.

SIMON L. SIMPSON, OF NEW YORK, N. Y.

SPRING-BED.

SPECIFICATION forming part of Letters Patent No. 701,408, dated June 3, 1902.

Application filed March 8, 1901. Serial No. 50,327. (No model.)

To all whom it may concern:

Be it known that I, SIMON L. SIMPSON, a citizen of the United States, residing in New York, borough of Manhattan, in the State of New York, have invented certain new and useful Improvements in Spring-Beds, of which the following is a specification.

This invention relates to certain improvements in spring-beds; and the object of the invention is to provide a spring-bed adapted for use with iron or metallic bedsteads of the usual construction and which is adapted to be folded into narrow compass for convenient packing and shipping.

The invention consists of a spring-bed comprising a plurality of slats extending transversely to the direction of collapse, each slat having hooked ends adapted to engage the rails of a bedstead and a vertical portion between said ends, seats on the slats, folding links pivoted to and supported by said seats and arranged in the direction of collapse, said seats being composed each of a shank adapted to be attached to the slat and to support a link above and out of contact with the same and a pivot extending upwardly from said shank, and bed-springs supported on said slats; and the invention consists, further, of certain details of construction and combinations of parts, which will be fully described hereinafter and finally pointed out in the claim.

In the accompanying drawings, Figure 1 represents a plan view of my improved spring-bed shown as extended ready for use. Fig. 2 is a plan view showing the same folded up ready for shipment. Fig. 3 is a plan view of a portion of the spring-bed, drawn on a larger scale. Fig. 4 is a side elevation of Fig. 3; and Fig. 5 is a vertical section, on a larger scale, on line 5 5, Fig. 4.

Similar letters of reference indicate corresponding parts.

Referring to the drawings, A indicates the supporting-slats of my improved spring-bed. The slats are preferably made of suitable sheet-steel, the transverse portions *a* being bent at right angles to the hook-shaped ends *a'*, so that the portion *a* of each slat between the ends of the same is thereby prevented from bending, forming a stiff transverse connection of the ends. The slats A are con-

nected by pivot-links *b*, which are pivoted to suitable seats, each composed of a shank, the lower portion *d* of which is secured by a rivet *d'* or other means to the vertical middle portion *a* of the slat, and a pivot extending upwardly from the horizontal portion *d²* of the shank. The seats serve to support the links above and out of contact with the upper edges of the slats, as shown, the links not being supported directly on the slats, but on the seats. The two folding links between each slat are pivoted to the seats at one end and pivotally connected to each other at their inner ends, so as to permit the folding up of the slats alongside each other and also the convenient folding of the links above said slats. To the slats are attached the lower ends of conical springs C, the lower end of each spring being bent into the shape of an eye parallel with the middle portion of the slats and applied by a rivet *r* to the slat, as shown clearly in Fig. 4. The upper larger ends of the conical springs C are connected by short chains *c*, links, or otherwise, so that a stiffening connection between their upper ends is obtained.

For shipment the entire bed is folded together into comparatively small space by folding the links, bringing the ends of the bed closer to each other, so that the angular hooked ends of the slats abut. The upper ends of the springs fold one into the other, as shown in Fig. 2, so that the entire spring-bed can be readily packed for shipment. When required for use, the spring-bed is extended to its full length, as shown in Fig. 1, the pivot-links being in line with each other and placed at right angles to the slats. In this position the bed is placed in the metallic or other bedstead, the angular hook-shaped ends of the slats being hooked upon the side rails of the bedstead.

My improved spring-bed has the advantage that by the vertical position of the middle or transverse portion of the slats no bending through of the slats under the weight is possible so that a stiff bottom for the spring-bed is obtained; secondly, that the folding links are pivoted to horizontal seats located above the upper edges of the transverse slats, so that they can be freely folded into a plane above the same, and, lastly, that the lower

ends of the springs of the bed are firmly attached to the vertical transverse portions of the slats by means of the eyes at the lower ends of the springs, so that a stiff spring-bed
 5 is obtained when extended for use, which has all the elasticity of the ordinary spring-beds, while it has also the advantage of being conveniently folded up for storage or shipment.

Having thus described my invention, I
 10 claim as new and desire to secure by Letters Patent—

A collapsible spring-bed, consisting of a plurality of slats extending transversely to the direction of collapse, each slat having
 15 hooked ends adapted to engage the rails of a bedstead, and a vertical portion between said

ends, seats on the slats, folding links pivoted to and supported by said seats, and arranged in the direction of collapse, said seats being composed each of a shank adapted to be at- 20 tached to the slat and to support a link above and out of contact with the same, and a pivot extending upwardly from said shank, and bed-springs supported on said slats, substantially as set forth. 25

In testimony that I claim the foregoing as my invention I have signed my name in presence of two subscribing witnesses.

SIMON L. SIMPSON.

Witnesses:

PAUL GOEPEL,
 JOSEPH H. NILES.