

July 15, 1952

J. J. REYNOLDS

2,602,956

SASH HANGER

Filed Nov. 24, 1950

Fig. 1.

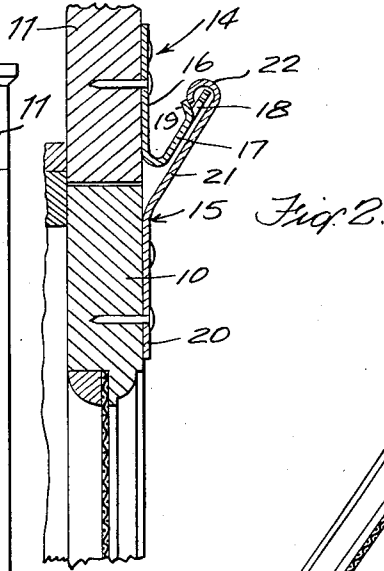
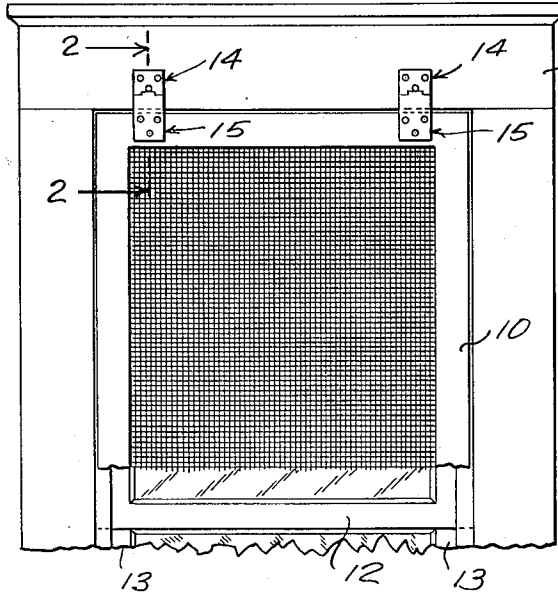

Fig. 2.

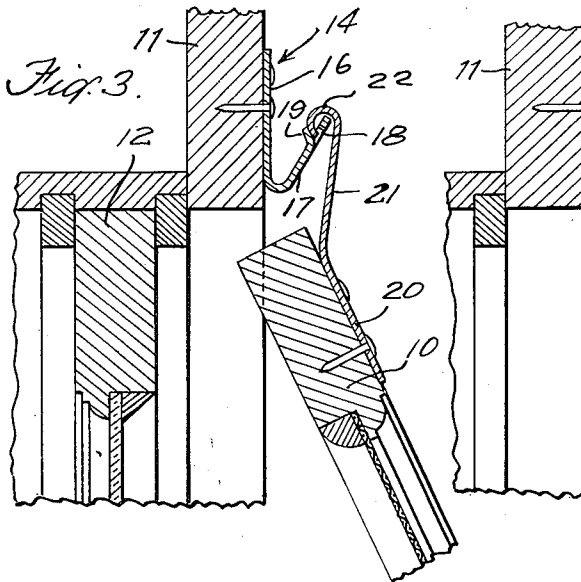

Fig. 3.

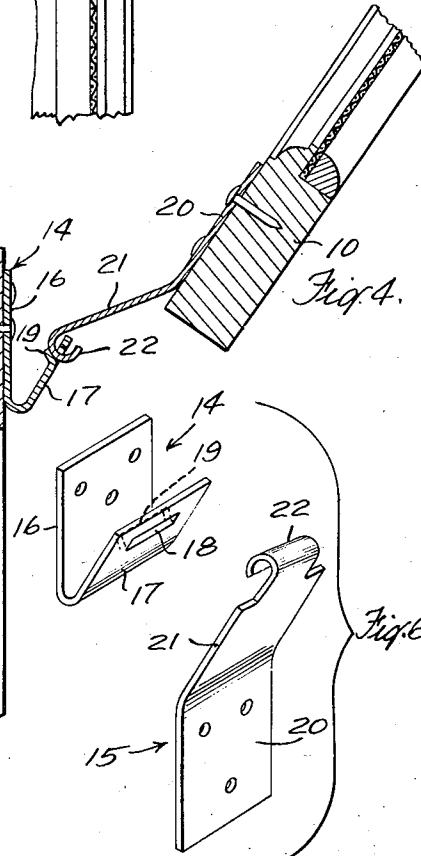

Fig. 4.

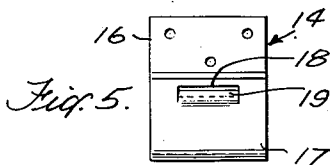

Fig. 5.

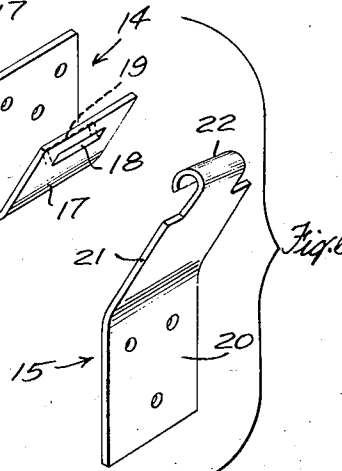

Fig. 6.

Inventor

JOHN J. REYNOLDS

By

Victor D. Borst

Attorney

UNITED STATES PATENT OFFICE

2,602,956

SASH HANGER

John J. Reynolds, East Orange, N. J.

Application November 24, 1950, Serial No. 197,480

2 Claims. (Cl. 16-172)

1

This invention relates to fixtures used on the outside of window frames to hang screens and storm window sashes and to allow the sashes to swing on the fixtures as a hinge.

One of the prime desiderata of such fixtures is facility in hanging and removing the sashes. Another and important desideratum is safety or security of attachment of the sash in all positions of use. Other general desiderata are simplicity of construction, economy in production cost and attractiveness of appearance.

The present invention satisfies these desiderata. Each hinge, of which there will normally be two, consists of two sheet metal parts, one permanently attached to the frame of the window properly disposed immediately above the opening, and the other attached to the upper sash rail and having an upwardly extending hook portion to engage with a hanger portion of the hinge part on the frame. In accordance with the invention the parts are so constructed that the sash hinge part is guided into interengaging relation with the cooperative frame hinge part as the sash is moved up in the window frame at a slight inclination, so that the hook naturally catches over the hanger portion as the sash is lifted up at this angle. The sash, which is then free to hinge on the hanger, is unrestrained against relative vertical movement of the hinge parts until in the opening movement the sash leaves the window frame and is no longer under lateral restraint. Then the interengagement between the hinge members becomes inseparable. In other words, the hook portion of the sash hinge member separately engages the hanger portion of the frame hinge member so long as the angle of the sash is such that the sash is under lateral restraint, but the engagement is inseparable when the opening movement of the sash brings it outside the frame. This makes it easy to hang and remove the sash but prevents the sash from blowing off or being otherwise accidentally removed in its more widely open position where it is clear of the frame.

These features will appear more clearly from a consideration of the embodiment of the invention illustrated in the accompanying drawings in which

Fig. 1 is an outside elevation of the upper portion of a window frame with a corresponding portion of a screen containing sash in the opening attached and hung by a hinge construction embodying the invention.

Fig. 2 is a fragmentary vertical section on enlarged scale through one of the hinges and im-

2

mediately adjacent parts, being on the line 2-2 of Fig. 1.

Fig. 3 is a sectional view similar to Fig. 2 but showing the sash in partially open position, substantially that in which it would be applied or removed.

Fig. 4 is a similar sectional view of the parts shown in Fig. 2 but showing the sash in wide open position.

Fig. 5 is an outside elevational detail of the frame hinge part.

Fig. 6 is an exploded perspective of the hinge parts disengaged.

In Fig. 1 two hinge fixtures are shown which is the usual number. The screen sash 10 is shown in the window opening attached by the fixtures to the top member of the window frame 11, the screen being disposed outside the sliding window sashes 12 and 13. Since the two hinge constructions are the same, a description of one will suffice.

The fixture consists of a hanger or frame member 14 and a hook or sash member 15. Each is formed of a strip of sheet metal shaped and fashioned for its particular function.

The frame hinge part 14 comprises a flat metallic strip bent on a transverse line to form a plate portion 16 which is attached by screws to the frame member 11, and a hanger portion 17 somewhat shorter than the plate portion and extending upwardly and outwardly at an acute angle from the bottom of the plate portion. Near its top edge the hanger portion 17 is provided with a transverse slot 18, the metal for the purpose being cut along the top and two ends and turned inwardly to form a lip 19.

The sash hinge part 15 comprises a flat metallic strip of substantially the same width as that of the frame part 14, which is bent on a transverse line to form a plate portion 20 which is attached by screws to the top rail of the screen sash 10, and a hook portion 21 extending upwardly and outwardly from the top of the plate portion at an obtuse angle which is a supplement of the acute angle between the two elements of the frame hinge part, as shown in Fig. 2. At its top the hook portion is reduced in width to substantially the length of the slot 18, and the narrow extension is bent inwardly to form an arcuate hook 22.

The arcuate length of the hook 22 is such that it engages in the slot 18 only when the sash is opened outward to a substantial angle to the vertical, beyond that necessary for hanging or removing the sash. The parts are so designed

3

and proportioned that the hook begins to enter the slot in the opening movement of the sash approximately as the top of the sash leaves the window frame opening which is approximately the position shown in Fig. 3. Up to that position the sash may be lifted off. And in applying it, the sash is guided in the frame so that the hooks come into registry with the slots.

The slot 18 is so disposed and the hook 22 is formed to such a radius that the hook bears on the lip 19 and the hook clears the top edge of the hanger portion 17, as shown in Figs. 2, 3 and 4. Thus friction in the hinging action is minimized. The lip desirably is made arcuate concentric with the axis of the hook and constitutes the bearing on which the hook turns.

It is apparent that the hinge parts must be properly located for cooperative action. For this purpose a suitable template may be employed for spotting the screw holes, and, if desired, locating arms may be struck out and bent in from one or both of the parts, in the one case to bear on top of the sash and in the other case to bear on the bottom face of the top frame member.

It is to be noted that by virtue of this construction the suspension radius of the sash is of such length and the hinging axis is so located above and in front of the sash that there is a substantial downward component of movement to the sash at the beginning of its opening movement, as shown in Fig. 3.

As shown in Fig. 2, when the sash is hung and is closed, the hook portion 21 is parallel and in close proximity to the hanger portion 17. When the sash is applied, it is grasped at its lower end and entered with its top end into the frame opening and is lifted up until the hook 22 strikes the hanger portion 17 and rides up that face until the inwardly turned hook catches over the top of the hanger portion. The sash is then hung and can be removed only by lifting the hook off the hanger portion. The lateral guiding of the sash assures that the hooks are in position to engage in the slots as the sash is further opened.

While the invention has been described in connection with a suitable embodiment thereof, it will be understood that the invention is not limited to this form in all particulars but that changes will occur to those skilled in the art

4

which come within the principle and scope of the invention as defined in the following claims.

I claim:

1. A sash hanger including interengageable frame and sash members, the frame member having a plate portion securable to a window frame and a hanger portion extending upwardly and outwardly at an acute angle from the plate portion, the hanger portion providing an outstanding free edge at its upper end and having a transverse slot near said edge, and a sash member having a plate portion securable to a sash and a hook portion extending upwardly and outwardly from the plate portion at an obtuse angle which is substantially the complement of the said acute angle, the upper end of the hook portion constituting a hook and being curved inwardly in the form of a hook through an arc exceeding 180° and the hook portion being of a length to engage with its hook upon the free edge of the said hanger portion when the two plate portions are in the same plane, the slot being proportioned to receive the hook and the radius of curvature of the hook being substantially half the distance of the center line of the slot from the said free edge, whereby the end of the hook will enter the slot when the hook bears upon the said free edge upon outward rotation of the sash.

2. A sash hanger as defined in claim 1 in which the hanger portion has an inwardly extending guide lip coincident with the bottom edge of the slot to guide the end of the hook into the slot.

JOHN J. REYNOLDS.

REFERENCES CITED

The following references are of record in the file of this patent:

UNITED STATES PATENTS

Number	Name	Date
610,010	Winter	Aug. 30, 1898
676,509	McNown	June 18, 1901
1,007,406	Warner	Oct. 31, 1911
1,018,603	Bittorf	Feb. 27, 1912
1,369,246	Jones	Feb. 22, 1921

FOREIGN PATENTS

Number	Country	Date
462,172	France	Sept. 4, 1913