

J. A. AYRES.

MACHINES FOR RAISING WATER.

No. 183,742.

Patented Oct. 31, 1876.

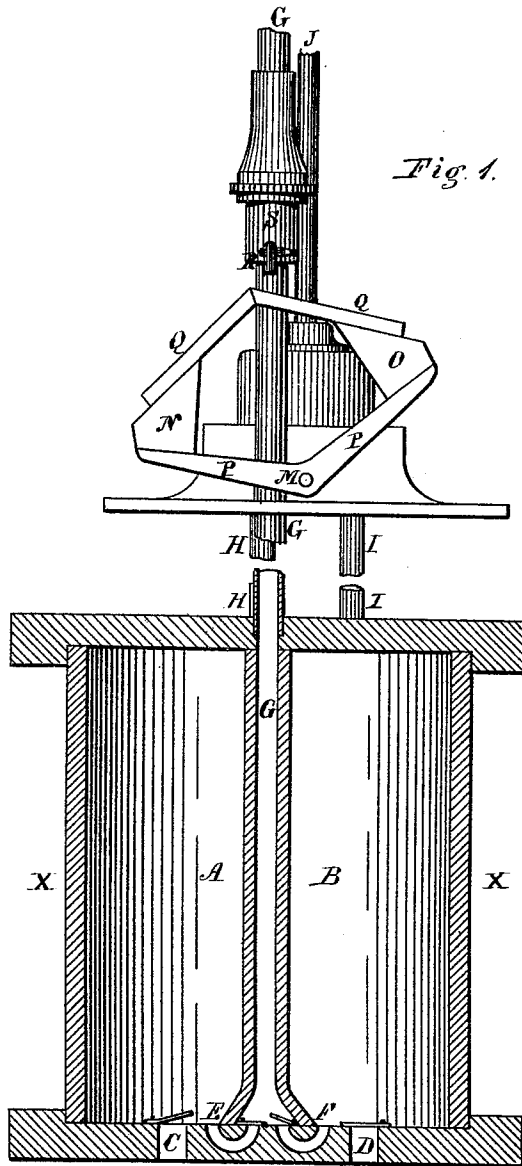

Fig. 1.

WITNESSES.

John S. Peters
Hugh O. Flaherty

INVENTOR.

James A. Ayres
by Theo. G. Ellis, Attorney

J. A. AYRES.
MACHINES FOR RAISING WATER.

No. 183,742.

Patented Oct. 31, 1876.

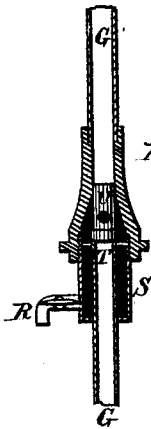

Fig. 4.

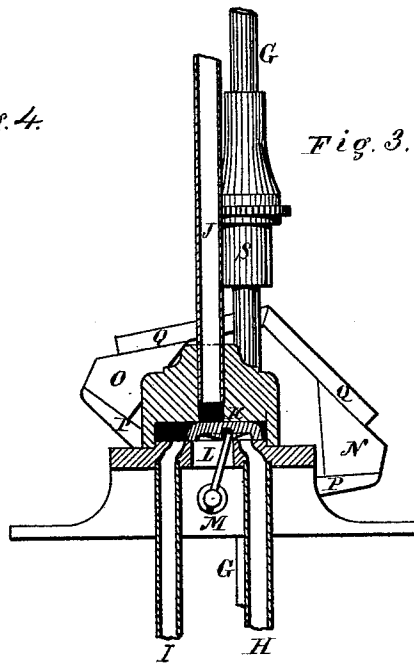

Fig. 3.

Fig. 5.

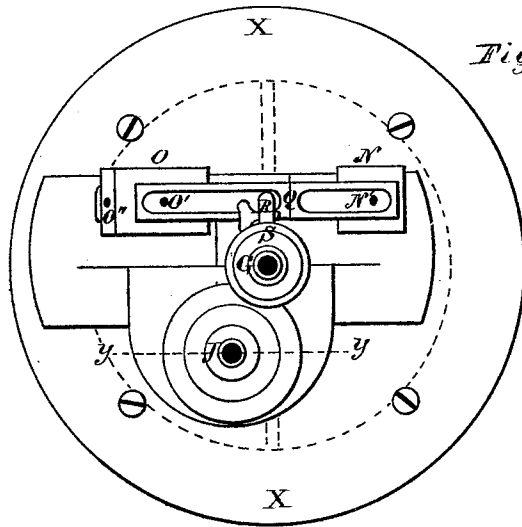

Fig. 2.

WITNESSES.

John J. Peters
Hugh O'Flaherty

INVENTOR.

James A. Ayres
by Theo. G. Ellis, Attorney

UNITED STATES PATENT OFFICE

JARED A. AYRES, OF HARTFORD, CONNECTICUT.

IMPROVEMENT IN MACHINES FOR RAISING WATER.

Specification forming part of Letters Patent No. **183,742**, dated October 31, 1876; application filed May 3, 1876.

To all whom it may concern:

Be it known that I, JARED A. AYRES, of Hartford, in the county of Hartford and State of Connecticut, have invented certain new and useful Improvements in Machines for Raising Water; and I do hereby declare that the following is a full, clear, and exact description thereof, whereby a person skilled in the art can make and use the same, reference being had to the accompanying drawings, and to the letters of reference marked thereon.

Like letters in the figures indicate the same parts.

My invention relates to apparatus for raising water by means of compressed air, in which the water is forced alternately out of two chambers into which it flows, by gravity, in such a manner as to rise in a continuous stream.

The object of my invention is to provide an automatic valve apparatus, for operating the valve which directs the supply of compressed air to the two chambers alternately, which can be placed at any point desired in the line of the water-supply pipe, however distant from the well or place from which the water is drawn.

My invention consists in operating the valve automatically, by means of a small stream of water, of minute quantity compared with the whole discharge, taken from any point of the delivery-pipe; also in the construction and arrangement of the mechanism by which the desired result is attained.

In the accompanying drawings, on two sheets, Figure 1 is a front view of my improved mechanism for raising water, with the front of the water-chambers removed in order to show the interior parts. Fig. 2 is a top view of the valve mechanism, showing the water-chambers underneath. Fig. 3 is a rear view of the valve mechanism, showing a section upon the line Y Y of Fig. 2. Fig. 4 is a section through the delivery-pipe, showing the manner of drawing the supply for operating the valve. Fig. 5 is a view of the under side of the valve which changes the direction of the current of compressed air.

A and B are two water-chambers, usually placed below the surface of the water in a well or cistern, so that the water enters them

by the force of gravity through the valves C and D, to fill them. These chambers are shown in the drawings as being formed in the cylinder X X, which is divided by a partition through the middle. E and F are passages, furnished with check-valve, leading into the delivery-pipe G, which passes through the top of the cylinder to where the water is to be used. H and I are air-pipes, for conducting the compressed air into the chambers A and B, alternately, to force out the water. J is the main air-pipe, leading from an air-pump or a reservoir of compressed air. The air is directed into one or the other of the pipes H or I by means of a slide-valve K, which at each movement throws one of these pipes into communication with J, while the other is opened to the atmosphere through the port L.

The valve K is operated by means of an arm upon a rocking-shaft, M, to which motion is communicated in the following manner: N and O are buckets placed upon the outer ends of the rocking lever P, which is keyed to the shaft M. These buckets are alternately filled with water from a small cock or opening, B, drawing a minute quantity of water from the main ascending pipe G. They are arranged with a suitable spout, Q, for conducting the water into the one which is uppermost, while the other is discharging. O' and N' show the apertures for filling, and O'' shows one of the apertures for discharging.

In the drawings the bucket O is shown in the position for filling, and N in the position for discharging. When O becomes full and N empty, or nearly so, the bucket O descends and N rises, thus reversing the operation and moving the valve K to the opposite end of its throw. The cock in R regulates the quantity of water supplied to the buckets, so as to cause the valve to be operated as rapidly or as slowly as may be desired.

S is a small reservoir, shown in the drawing as surrounding the pipe G, into which the water passes through the opening I, and from the bottom of which it is drawn out through the opening R. This reservoir is for the purpose of retaining a sufficient supply of water to operate the valve, if at any time, on account of suddenly drawing a large quantity of water, or otherwise, by accident, the water should

all be blown out of the pipe G. The water remaining in the reservoir would then throw the valve, and the apparatus would again be ready to furnish a further supply. U is a check-valve, placed in the pipe G above the reservoir, to prevent a reflux of the water above it.

By means of my invention, the valves for automatically operating the continuous supply of water from the submerged chambers can be placed at any desired distance from the well or other point of supply. It can be placed in the well above the surface of the water, or it can be removed to where the water is delivered.

What I claim as my invention is—

1. The combination of the chambers A and B, the water-pipe G, the air-pipes H I J, and a valve, K, for changing the direction of the

current of air, the said valve being operated by a small stream of water drawn from the delivery-pipe G, substantially as herein described.

2. The combination of the oscillating buckets N O, the shaft M, the valve K, and the air-pipes H I J, with an aperture for taking a minute stream of water from the delivery-pipe G, for the purpose of operating the said parts, substantially as herein set forth.

3. The reservoir S, in combination with the oscillating buckets N O and the pipe G, substantially as and for the purpose herein described.

J. A. AYRES.

Witnesses:

WM. A. AYRES,
THEO. G. ELLIS.