

(12) PATENT
(19) AUSTRALIAN PATENT OFFICE

(11) Application No. AU 200195223 B2
(10) Patent No. 783862

(54) Title
Bone cement mixing apparatus having improved gearing arrangement for driving a mixing blade

(51)⁷ International Patent Classification(s)
B01F 007/20 B28C 005/32

(21) Application No: **200195223** (22) Application Date: **2001.11.30**

(30) Priority Data

(31) Number	(32) Date	(33) Country
60/250808	2000.12.01	US
10/002045	2001.11.15	US

(43) Publication Date : **2002.06.06**

(43) Publication Journal Date : **2002.06.06**

(44) Accepted Journal Date : **2005.12.15**

(71) Applicant(s)
DePuy Products, Inc

(72) Inventor(s)
Timothy G. Vendrely; Jack F. Long; Christopher Battles; Paul Decesare; Patrick Gutelius; Sam Sackett

(74) Agent/Attorney
Freehills Patent and Trade Mark Attorneys, Level 43, 101 Collins Street, MELBOURNE VIC 3000

(56) Related Art
WO 1995/013862

Abstract of the Invention

A bone cement mixing device has a canister which is modular in design and constructed from a transparent material. The mixing device further has a mixing head assembly having a crank which is operatively
5 coupled to a mixing blade via a gear train. The gear train is configured to drive the mixing blade in a reciprocating manner including the varying of the angular velocity, direction of travel, and angular distance of travel of the blade while the crank is rotated at a constant velocity and direction. The mixing blade has a fluid passage defined therein which allows the
10 liquid cement component to be delivered at various locations within the mixing chamber of the canister. A method of mixing bone cement is also disclosed.

AUSTRALIA

Patents Act 1990

**ORIGINAL
COMPLETE SPECIFICATION
STANDARD PATENT**

Invention Title: **Bone cement mixing apparatus having improved gearing
arrangement for driving a mixing blade**

The following statement is a full description of this invention, including the best
method of performing it known to us:

1A

**Bone cement mixing apparatus having improved gearing arrangement
for driving a mixing blade**

Technical field of the invention

The present invention relates generally to a surgical assembly, and more particularly to
5 an apparatus and method for mixing bone cement.

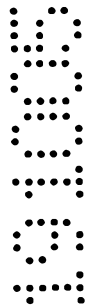
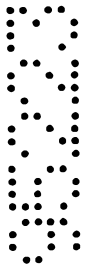

Background of the Invention

It is necessary in many orthopedic surgical procedures to employ a cement or grouting type agent, such as for attaching artificial joint implants, repairing or forming joints in bones, or other forms of orthopedic work. The type of cement generally used for these purposes is a self-curing resin formed from the blending of a wide variety of liquid monomers or comonomers with powdered polymers or copolymers to form a viscous admixture to be used as the grouting agent.

The admixture of the powder and liquid components develops a quick setting material. As such, preparation of the cement usually occurs directly within the operating area just prior to use. In particular, a bone cement mixing apparatus is generally utilized to mix the powder and liquid components in the operating area. The resultant admixture is then removed from the mixing apparatus and placed in a cement delivery apparatus for subsequent use by the surgeon. Specifically, the bone cement must generally first be scooped or otherwise removed from the mixing apparatus and thereafter placed in a syringe-type delivery apparatus for use by the surgeon.

The aforescribed system for mixing and delivering bone cement has a number of drawbacks associated therewith. For example, monomer vapors are generated during the depositing of the monomer into the mixing apparatus and during the subsequent mixing of the monomer with the powder component of the bone cement. Such monomer vapors may

be noxious and/or toxic. Because the bone cement is generally mixed in the operating room environment, it is important to prevent any monomer or its vapors from escaping the mixing apparatus. However, heretofore designed mixing apparatus have not included mechanisms for controlling
5 the escape of such vapors.

Moreover, heretofore designed mixing apparatus have been plagued with problems relating to the incomplete mixing of the liquid component and the powder component. Specifically, the powder component and liquid component are often inadequately mixed during
10 operation of heretofore designed systems. Such a problem is further compounded by the fact that heretofore designed mixing vessels are not transparent thereby preventing the contents of the vessel (i.e. the bone cement) from being viewed by the operator of the mixing apparatus.

In addition, the aforescribed system also suffers from
15 operational inefficiencies relating to the need to transfer the mixed bone cement from the mixing apparatus to the delivery apparatus. Specifically, the need to remove the mixed bone cement from one device (i.e. the mixing apparatus) and place it in a second device (i.e. the delivery device) creates an extra step in the process thereby increasing the time
20 necessary to deliver the mixed bone cement. Moreover, a quantity of the bone cement is lost in the process since it is highly unlikely that all of the mixed cement is actually removed from the mixing apparatus and placed in the delivery apparatus.

What is needed therefore is an apparatus and method for mixing a bone cement which overcomes one or more of the above-mentioned drawbacks. What is particularly needed is an apparatus and method for mixing bone cement which reduces, if not eliminates, exposure to vapors from the liquid bone cement component within the operating area. What is further needed is an apparatus and method for mixing bone cement which may also be utilized to delivery the mixed bone cement. What is moreover needed is an apparatus and method for mixing bone cement which reduces, or even eliminates, the occasions in which a portion of the powder cement component is not thoroughly mixed with the liquid cement component.

Summary of the Invention

In accordance with the concepts of the present invention, there is provided a bone cement mixing device having a canister which is modular in design and constructed from a transparent material. The mixing device further has a mixing head assembly having a crank which is operatively coupled to a mixing blade via a gear train. The gear train is configured to drive the mixing blade in a reciprocating manner including the varying of the angular velocity, direction of travel, and angular distance of travel of the blade while the crank is rotated at a constant velocity and direction. The mixing blade has a fluid passage defined therein which allows the

liquid cement component to be delivered at various locations within the mixing chamber of the canister.

Pursuant to another embodiment of the present invention, there is provided a bone cement mixing apparatus which includes a handle. The bone cement mixing apparatus further includes an input gear which is caused to rotate about a central axis in response to rotation of the handle, wherein (i) the input gear includes a first input gear teeth set and a second input gear teeth set, (ii) the first input gear teeth set is spaced a first radial distance from the central axis, (iii) the second input gear teeth set is spaced a second radial distance from the central axis, (iv) the second radial distance is greater than the first radial distance, (v) the first input gear teeth set extends outwardly away from the central axis, and (vi) the second input gear teeth set extends inwardly toward the central axis. The bone cement mixing apparatus additionally includes an intermediate gear, wherein the input gear is configured so that during rotation thereof (i) the first input gear teeth set meshingly engages the intermediate gear during a first period of time, and (ii) the second input gear teeth set meshingly engages the intermediate gear during a second period of time which is different from the first period of time. The bone cement mixing apparatus also includes an output gear which is caused to rotate in response to rotation of the intermediate gear. Further, the bone cement mixing apparatus includes a mixing blade which is caused to rotate in response to rotation of the output gear.

Yet according to another embodiment of the present invention, there is provided a bone cement mixing apparatus which includes a handle and an input gear which is caused to rotate in response to rotation of the handle. The bone cement mixing apparatus also includes an
5 intermediate gear which is caused to rotate in response to rotation of the input gear, and an output gear which is caused to rotate in response to rotation of the intermediate gear. Further, the bone cement mixing apparatus includes a mixing blade which is caused to rotate in response to rotation of the output gear. In response to the input gear being rotated
10 one revolution, the intermediate gear is driven (i) a first rotational distance in a counterclockwise direction of rotation, and (ii) a second rotational distance in a clockwise direction of rotation. Additionally, the first rotational distance is less than the second rotational distance.

Yet according to another embodiment of the present invention,
15 there is provided a bone cement mixing apparatus (i) a handle, (ii) an input gear which is caused to rotate in response to rotation of the handle, (iii) an intermediate gear which is caused to rotate in response to rotation of the input gear, (iv) an output gear which is caused to rotate in response to rotation of the intermediate gear,; and (v) a mixing blade
20 which is caused to rotate in response to rotation of the output gear. The intermediate gear is driven to rotate at a first output angular velocity during a first period of time in response to the input gear being rotated at an input angular velocity. Also, the intermediate gear is driven to rotate at

a second output angular velocity during a second period of time in response to the input gear being rotated at the input angular velocity. Moreover, the first angular velocity is less than the second angular velocity, and the first period of time is different from the second period of time.

In accordance with still another embodiment of the present invention, there is provided a bone cement mixing apparatus which includes an input gear which is configured to rotate about a central axis, wherein (i) the input gear includes a first input gear teeth set and a second input gear teeth set which are spaced apart from each other, and (ii) the first input gear teeth set extends outwardly away from the central axis, and (iii) the second input gear teeth set extends inwardly toward the central axis. The bone cement mixing apparatus further includes an intermediate gear, wherein the input gear is configured so that during rotation thereof (i) the first input gear teeth set meshingly engages the intermediate gear during a first period of time, and (ii) the second input gear teeth set meshingly engages the intermediate gear during a second period of time which is different from the first period of time. Moreover, the bone cement mixing apparatus also includes a mixing blade which is caused to rotate in response to rotation of the intermediate gear.

According to yet still another embodiment of the present invention, there is provided a bone cement mixing apparatus includes an input gear which is configured to rotate about a central axis, wherein (i) the input

gear includes a first input gear teeth set and a second input gear teeth set which are spaced apart from each other, and (ii) the first input gear teeth set extends outwardly away from the central axis, and (iii) the second input gear teeth set extends inwardly toward the central axis. The bone cement mixing apparatus further includes a slave gear which is caused to rotate in response to rotation of the input gear. The bone cement mixing apparatus also includes a mixing blade which is caused to rotate in response to rotation of the slave gear.

Reference to any prior art in the specification is not, and should not be taken as, an acknowledgment, or any form of suggestion, that this prior art forms part of the common general knowledge in Australia or any other jurisdiction or that this prior art could reasonably be expected to be ascertained, understood and regarded as relevant by a person skilled in the art.

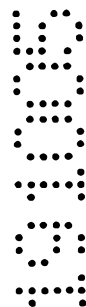
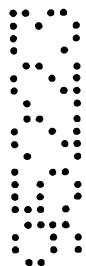

The above features and advantages of the present invention will become apparent from the following description and the attached drawings.

Brief description of the drawings

FIG. 1 is a perspective view of bone cement mixing device which incorporates the 5 features of the present invention therein;

FIGS. 2-5 are side elevational views of the mixing device of FIG. 1;

FIG. 6 is an enlarged plan view of the mixing device of FIG. 1;

FIG. 7 is a cross sectional view of the mixing device of FIG. 1, taken along the line 7-7 of FIG. 5, as viewed in the direction of the arrows;

10 FIG. 8 is a cross sectional view taken along the line 8-8 of FIG 3, as viewed in the direction of the arrows;

FIG. 9 is a cross sectional view taken along the line 9-9 of FIG. 2, as viewed in the direction of the arrows;

FIG. 10 is a cross sectional view taken along the line 10-10 of FIG. 4, as viewed in the 15 direction of the arrows;

FIG. 11 is a cross sectional view taken along the line 11-11 of FIG. 4, as viewed in the direction of the arrows;

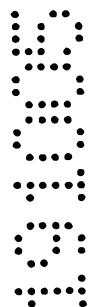
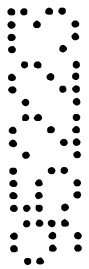

FIGS. 12-14 are exploded perspective views of the mixing head assembly of the mixing device of FIG. 1;

FIGS. 15 and 16 are bottom perspective views of the gear train of the mixing head assembly of FIGS. 12-14;

5 FIG. 17 is a bottom perspective view of the directional gear of the gear train of FIGS. 15 and 16;

FIGS. 18-20 are fragmentary perspective views which show the blade wiping diaphragm of the mixing device of FIG. 1;

10 FIG. 21 is fragmentary plan view of the blade wiping diaphragm of FIGS. 18-20 and the mixing blade of FIG. 7;

FIG. 22 is a fragmentary side elevational view of the blade wiping diaphragm of FIGS. 18-20 and the mixing blade of FIG. 7;

FIGS. 23 and 24 are fragmentary perspective views of the mixing device of FIG. 1 with the cement delivery nozzle secured thereto; and

15 FIG. 25 is an enlarged view of the cement delivery nozzle of FIGS. 23 and 24.

Detailed Description of the Invention

While the invention is susceptible to various modifications and alternative forms, a specific embodiment thereof has been shown by way of example in the drawings and will herein be described in detail. It should be understood, however, that there is no intent to limit the invention to the particular form disclosed, but on the contrary, the intention is to cover all modifications, equivalents, and alternatives falling within the spirit and scope of the invention.

Referring now to FIGS. 1-7, there is shown a bone cement mixing device 10 which incorporates the features of the present invention therein. As shall be discussed below in greater detail, the bone cement mixing device 10 of the present invention is configured to receive a quantity of a powder bone cement component and a liquid bone cement component (e.g. a monomer) and thereafter mix the powder component and liquid component together. The bone cement mixing device 10 is also operable as a bone cement delivery device thereby eliminating the need to utilize a separate delivery device.

The mixing device 10 includes a canister 12 having a mixing chamber 14 defined therein. The canister 12 is preferably embodied as a pair of identical cylindrically-shaped cartridges 16, 18. Use of the cartridges 16, 18 allows for modular construction of the mixing device 10 while also reducing the number of different components which are utilized in the design thereof.

Each of the cartridges 16, 18 is preferably constructed of a transparent material such as a transparent plastic material. Such use of a transparent material in the construction of the cartridges 16, 18 is advantageous in that the operator the mixing device may visually observe
5 the contents within the mixing chamber 14 (i.e. the powder and liquid cement components) in order to visually determine if the components have been adequately (i.e. thoroughly) mixed with one another.

Moreover, the cartridges 16, 18 may be constructed to accommodate any quantity of bone cement. Preferably, the cartridges 16,
10 18 are constructed to hold and mix at least 120 grams of powder bone cement component and the associated quantity of the liquid bone cement component (i.e. the monomer). Such a configuration is advantageous in that surgical procedures commonly require the preparation of three (3) batches of bone cement powder (with each batch being 40 grams). It is
15 often necessary when using a heretofore designed mixing apparatus for each of the three batches to be prepared (i.e. mixed) separately thereby potentially creating delays and/or timing difficulties within the operating area during a surgical procedure. However, the mixing device 10 of the present invention overcomes this limitation by being configured to mix all
20 three of the batches simultaneously.

The upper end 20 of each of the cartridges 16, 18 has a first number of threads 22 defined therein, whereas the lower end 24 of each of the cartridges 16, 18 has a corresponding number of threads 26

defined therein. The threads 22, 26 may be threadingly engaged with one another (as in the case of the junction between the cartridges 16, 18), or may be engaged to a number of other components. In particular, as shown in FIG. 7, the threads 22 of the upper end 20 of the cartridge 16 are threadingly engaged with a number of threads 28 associated with a mixing head assembly 30. The threads 26 of the lower end 24 of the canister 18, on the other hand, are threadingly engaged with a number of threads 32 defined in a base 34. It should be appreciated that sealing members such as O-rings 158 (see FIGS. 7, 9, and 23) are preferably utilized at each threaded coupling (i.e. between the cartridges 16, 18, between the cartridge 16 and the mixing head assembly 30, and between the cartridge 18 and the base 34).

As shown in FIGS. 1, 7, and 9, the mixing head assembly 30 includes an upper gear housing 36 and a lower gear housing 38. The upper gear housing 36 is press fit or otherwise secured to the lower gear housing 38. The mixing head assembly 30 also includes a crank 40 which is rotatably secured to the upper gear housing 36. The crank 40 includes an elongated arm 42 having a knob 44 rotatably secured to an end thereof. As will be discussed below in greater detail, the upper gear housing 36 and the lower gear housing 38 cooperate to house a gear train 46 which is driven by rotation of the crank 40. Specifically, the gear train 46 includes an output pinion 48 which is rotatably coupled to the lower gear housing 38. The output pinion 48 includes a downwardly

extending coupling portion 50 which extends through an aperture 51 defined in the lower gear housing 38 (see also FIG. 13). The coupling portion 50 of the output pinion 48 is non-rotatably secured to an upper end 106 of a mixing blade 52. In particular, as shown in FIGS. 9 and 12, the coupling portion 50 of the output pinion 48 includes a number of barbs 58 which are received into a corresponding number of slots 60 (see FIGS. 7 and 9) defined in a coupling portion 108 of the mixing blade 52. Hence, rotation of the output pinion 48 causes similar rotation (i.e. in the same direction and at the same angular velocity) of the mixing blade 52.

10 Referring now to FIGS. 12-17, the mixing head assembly 30 is shown in greater detail. In addition to the crank 40 and the gear housings 36, 38, the mixing head assembly 30 also includes a directional gear 54, an idler gear 56, and the output pinion 48. As shown in FIGS. 12 and 13, the directional gear 54, the idler gear 56, and the output pinion 48 are
15 housed within the housing defined by the upper gear housing 36 and the lower gear housing 38. Specifically, the output pinion 48 has a shoulder 60 defined therein. Upon insertion of the coupling portion 50 of the output pinion 48 into the aperture 51 defined in the lower gear housing 38, the shoulder 60 of the output pinion 48 contacts a retaining surface 62 of the
20 gear housing 38 (see FIG. 13) thereby retaining the output pinion 48 while also allowing it to rotate relative to the gear housing 38.

The idler gear 56 has an aperture 64 defined therein (see FIG. 12) which is received around a post 66 (see FIGS. 13 and 14) defined in the

lower gear housing 38 thereby rotatably securing the idler gear 56 to the lower gear housing 38. The other end of the idler gear 56 has a post 68 extending therefrom which is received into a slot 70 defined in the body 72 of the directional gear 54 (see FIGS. 10 and 17). The post 68 is
5 captured by or is otherwise retained within the slot 70 during rotation of the directional gear 54.

The directional gear 54 is non-rotatably secured to the crank 40 by use of a hexagonally-shaped coupling mechanism 74. In particular, the crank 40 has a hexagonally-shaped member 76 extending downwardly
10 therefrom, whereas the body 72 of the directional gear 54 has a slightly larger hexagonally-shaped member 78 extending upwardly therefrom. During assembly of the mixing head assembly 30, a shoulder 80 of the crank is positioned in contact with a bearing surface 82 defined on the upper surface of the upper gear housing 36 (see FIG. 13) thereby
15 allowing the hexagonally-shaped member 76 of the crank 40 to extend through a housing opening 84 defined in the upper gear housing 36. When positioned in such a manner, the hexagonally-shaped member 76 of the crank 40 may be press fit or otherwise received into the hexagonally-shaped member 78 of the directional gear 54 which is
20 positioned within the upper gear housing 36 (see FIG. 11). When secured in such a manner, rotation of the crank 40 relative to the upper gear housing 36 causes similar rotation of the directional gear 54 relative

to the upper gear housing 36. Note that the directional gear 54 is caused to rotate about a central axis CA as shown in FIG 17.

The idler gear 56 is meshingly engaged with both the directional gear 54 and the output pinion 48. In particular, as shown in FIG. 17, the directional gear 54 includes a first number of gear teeth 86 defined in the body 72 thereof. The gear teeth 86 are positioned around a portion of the periphery of an aperture 88 which defines the axis of rotation of the directional gear 54. The directional gear 54 also includes a second number of gear teeth 90 defined in the body 72 thereof. As can be seen in FIG. 17, the gear teeth 90 are spaced radially outwardly from the gear teeth 86. As will be discussed below in greater detail, the gear teeth 86 and the gear teeth 90 selectively meshingly engage with the idler gear 56 so as to selectively drive the output pinion 48 (and hence the mixing blade 52) at varying velocities and directions of rotation.

Note that the central axis CA lies in a plane P which divides the directional gear 54 into a first directional gear side and a second directional gear side (see e.g. FIG. 17). Moreover, the directional gear 54 is configured so that (i) the gear teeth 86 are positioned entirely on the first input gear side, and (ii) the gear teeth 90 are positioned entirely on the second input gear side as shown in FIG. 17.

As shown in FIGS. 12-14, 15, and 16, the idler gear 56 has a number of gear teeth 92 defined therein, whereas the output pinion 48 has a number of gear teeth 94 defined therein. The gear teeth 92 of the

idler gear 56 are meshingly engaged with the gear teeth 94 of the output pinion 48. As such, rotation of the idler gear 56 in a given direction causes rotation of the output pinion 48 in the opposite direction. For example, clockwise rotation of the idler gear 56 causes counterclockwise rotation of the output pinion 48, and vice versa.

As alluded to above, the gear teeth 92 of the idler gear 56 are engaged by either the inner gear teeth 86 or the outer gear teeth 90 of the directional gear 54 during rotation of the directional gear 54. Specifically, during rotation of the directional gear 54 in the counterclockwise direction (as viewed from the bottom perspective view of FIGS. 15-17 and designated by the arrow 96), the idler gear 56 is initially engaged by the outer gear teeth 90 of the directional gear 54 thereby causing the idler gear 56 to likewise be rotated in the counterclockwise direction (as indicated by the arrow 96). Rotation of the idler gear 56 in the counterclockwise direction causes rotation of the output pinion 48 (and hence the mixing blade 52) in the opposite direction (i.e. in a clockwise rotation as viewed from the bottom perspective view of FIGS. 15-17 and designated by the arrow 98).

Continued rotation of the crank 40 (and hence the directional gear 54) in the counterclockwise direction (as viewed from the bottom perspective view of FIGS. 15-17 and indicated by the arrow 96) causes the last gear tooth 100 of the outer gear teeth 90 to be rotated out of engagement with the idler gear 56 and a first tooth 102 of the inner gear

teeth 86 to be rotated into meshing engagement with the idler gear 56. It should be appreciated that a small radial gap may be provided between the last gear tooth 100 of the outer gear teeth 90 and the first gear tooth 102 of the inner gear teeth 86 in order to prevent the idler gear 56 from
5 being simultaneously engaged by both sets of gear teeth 86, 90.

In any event, as the inner gear teeth 94 meshingly engage the idler gear 56, the direction of travel of the idler gear 56 is changed.

Specifically, when the directional gear 54 is rotated in the counterclockwise direction (as viewed from the bottom perspective view of
10 FIGS. 15-17 and indicated by the arrow 96), meshing engagement with the inner gear teeth 94 causes the idler gear 56 to be rotated in the opposite direction (i.e. the clockwise direction as viewed from the bottom perspective view of FIGS. 15-17 and indicated by the arrow 94). Such clockwise rotation of the idler gear 56 causes the output pinion 48 (and
15 hence the mixing blade 52) to be rotated in the opposite direction (i.e. the counterclockwise direction as viewed from the bottom perspective view of FIGS. 15-17 and indicated by the arrow 96).

It should be appreciated that if the crank 40 is rotated in the opposite direction (i.e. so as to cause rotation of the directional gear 54 in
20 the clockwise direction as viewed in FIGS. 15-17 and indicated by arrow 98), the idler gear 56 and the output pinion 48 are rotated in the respective opposite directions to that as described above. In particular, rotation of the directional gear 54 in the clockwise direction (i.e. in the

direction of arrow 98 of FIGS. 15-17) causes (1) clockwise rotation of the idler gear 56, and (2) counterclockwise rotation of the output pinion 48 (and hence the mixing blade 52) when the idler gear 56 is meshingly engaged with the outer gear teeth 90. Similarly, rotation of the directional gear 54 in the clockwise direction (i.e. in the direction of arrow 98 of FIGS. 15-17) causes (1) counterclockwise rotation of the idler gear 56, and (2) clockwise rotation of the output pinion 48 (and hence the mixing blade 52) when the idler gear 56 is meshingly engaged with the inner gear teeth 86.

Hence, as described above, the gear train 46 of the present invention is configured such that the direction of rotation of the output pinion 48 changes despite rotation of the crank 40 in only a single direction. Specifically, as the idler gear 56 is engaged with the outer gear teeth 90, the output pinion 48 and hence the mixing blade 52 is rotated in a first direction. However, as the idler gear 56 disengages the outer gear teeth 90 and engages the inner gear teeth 86, the direction of travel of the output pinion 48 and hence the mixing blade 52 is reversed thereby creating alternating or reciprocating motion.

Moreover, since the relatively large number of individual gear teeth associated with the outer gear teeth 90 creates a relatively large gear ratio with the idler gear 56 relative to the gear ratio created by inner gear teeth 86 and the idler gear 56, varying angular distances of travel and speeds of the mixing blade 52 are created. Specifically, the relatively

high gear ratio created by the outer gear teeth 90 causes the output pinion 48 to be driven across a greater angular distance when the idler gear 56 is engaged with the outer gear teeth 90 relative to the angular distance across which the output pinion 48 is driven when the idler gear 56 is engaged with the inner gear teeth 86. In one exemplary embodiment, the output pinion 48 (and hence the mixing blade 52) is driven across 540° of rotation when the idler gear 56 is engaged with the outer drive teeth 90, whereas the output pinion (and hence the mixing blade 52) is only advanced across 135° of rotation (in the opposite direction) when the idler gear 56 is engaged with the inner drive teeth 86. In other words, in such an exemplary embodiment, when an operator advances the crank 40 through an entire revolution (i.e. 360° of rotation), the mixing blade 52 is driven across 540° of rotation in a first direction and then reversed and driven across 135° of rotation in the opposite direction.

Moreover, the relatively high gear ratio created by the outer gear teeth 90 also causes the output pinion 48 to be driven at a greater angular velocity when the idler gear 56 is engaged with the outer gear teeth 90 relative to the angular velocity at which the output pinion 48 is driven when the idler gear 56 is engaged with the inner gear teeth 86. In one exemplary embodiment, when the idler gear 56 is engaged with the outer drive teeth 90, the output pinion 48 (and hence the mixing blade 52) is driven at a velocity which is approximately three times greater than the velocity at which the output pinion 48 (and hence the mixing blade 52) is

driven when the idler gear 56 is engaged with the inner drive teeth 86. In other words, in such an exemplary embodiment, when an operator advances the crank 40 through an entire revolution (i.e. 360° of rotation), the mixing blade 52 is driven three times as quickly in the first direction as it is when reversed and driven in the opposite direction.

It should be appreciated that the configuration of the directional gear 54 described herein is exemplary in nature and may be altered to fit the requirements of a given design of the mixing device 10. In particular, it should be noted that the number of teeth included in the gear teeth 86 and 90 may be varied in order to produce a desired gear ratio. Such modification to the gear teeth 86 and 90 would allow for modification to the angular distance and speed at which the mixing blade 52 is driven during rotation of the crank 40 by the operator.

It should also be appreciated that the aforescribed drive characteristics of the mixing head assembly 30 provide numerous advantages to the mixing device 10 of the present invention relative to heretofore designed mixing devices. For example, the aforescribed reciprocating movement of the mixing blade 52 (i.e. at varying angular distances and speeds) creates desirable "agitation" within the mixing chamber 14 of the canister 12. Such agitation increases the mix quality of the mixing device 10 by reducing, if not eliminating, the amount of the powder component which is not thoroughly mixed with the liquid component.

Referring now to FIG. 7, the mixing blade 52 will be described in greater detail. The mixing blade 52 includes an elongated central shaft 104 having an upper end 106 which includes the coupling portion 108 for securing the shaft 104 of the blade 52 to the coupling portion 50 of the output pinion 48. The shaft 104 also has a lower end 108 which extends downwardly and into contact with a plunger 110. The plunger 110 is made from a plastic material such as polyethylene. The plunger 110 includes a recess 112 which receives a tip 114 of the shaft 104 thereby providing mechanical support for the shaft 104 during rotation thereof.

A number of blades or vanes 116 extend outwardly from the shaft 104 as shown in FIG. 7. The mixing blade 52 may be configured as a "two-dimensional" (i.e. flat) blade, or alternatively, may be configured as a "three dimensional" blade. Specifically, although the vanes 116 may be configured to extend outwardly in only two directions from the shaft 104, the vanes 116 of the mixing blade 52 may also be configured to extend outwardly from the shaft 104 in three directions. In such a three dimensional configuration, the mixing blade 52 is not substantially flat when positioned on a relatively flat surface, but rather extends in a number of different directions (including upwardly) from the flat surface.

Moreover, as shown in FIG. 7, the vanes 116 are oriented in somewhat of a helical configuration around the shaft 104. Such a configuration provides numerous advantages to the mixing device 10 of the present invention. For example, the helical configuration of the mixing

blade 52 generates a desirable amount of "turbulence" within the mixing chamber 14 of the canister 12 thereby increasing the mixing efficiency of the mixing device 10.

The shaft 104 of the mixing blade 52 has an elongated fluid passageway 118 defined therein. The fluid passageway 118 extends from the upper end 106 of the shaft 104 to the lower end 108 of the shaft 104. The fluid passageway 118 is placed in fluid communication with the mixing chamber 14 of the canister 12 via a number of fluid orifices 120 defined in the shaft 104. While seven (7) fluid orifices 120 are shown defined in the shaft 104, it should be appreciated that there may be more than seven (7) fluid orifices defined in the shaft 104 (e.g. nine or ten fluid orifices). Alternatively, there may be less than seven (7) fluid orifices defined in the shaft 104 (e.g. two or three fluid orifices). The fluid passageway 118 and the fluid orifices 120 allow for the introduction of the liquid cement component (e.g. the monomer) without exposing the operator to any vapors or fumes from therefrom. In particular, as shown in FIG. 7, the crank 40 has a monomer delivery port 122 defined therein (see also FIG. 12). A tube 124 (see FIG. 7) is press fit into the lower end of the delivery port 122 and extends downwardly through the aperture 88 defined in the directional gear 54 and a similar aperture 126 defined in the output pinion 48 (see FIGS. 9, 12, 15, and 16). The lower end of the tube 124 is press fit or otherwise positioned in the coupling portion 108 of

the mixing blade 52 so as to be in fluid communication with the fluid passageway 118 defined in the shaft 104.

Hence, a quantity of liquid cement component may be introduced into the mixing chamber 14 of the canister 12 through the delivery port 122. Specifically, the liquid cement component (e.g. the monomer) may be introduced into the mixing chamber 14 via a fluid path which includes the delivery port 122, the tube 124, the fluid passageway 118 of the shaft 104, and the fluid orifices 120 of the shaft 104. In such a manner, the monomer may be delivered at various locations throughout the depth of the powder component which is present in the mixing chamber 14. In particular, since the fluid orifices 120 are provided at a number of different locations along the length of the shaft 104, the liquid component (e.g. the monomer) is delivered at locations throughout the height of the canister 12 thereby allowing the liquid to be interspersed throughout the powder component present in the mixing chamber 12. This is a significant advantage over heretofore designed systems in which the monomer is poured or otherwise advanced through the lid of the mixing apparatus thereby only allowing the monomer to be introduced to the "top" of the powder within the mixing apparatus. Moreover, the structure of the present invention also provide advantages over heretofore designed systems having a delivery path through the mixing shaft of the system which have an opening only at the bottom end of the shaft (similar to a common drinking straw). In such a configuration, the monomer flows only

out of the bottom of the shaft and in some cases may be restricted by the plunger on which the lower end of the shaft rests.

It should be appreciated that the monomer delivery port 122 may be embodied to include a luer lock that is configured such that a luer or
5 similar spout from a monomer delivery device (not shown) may be extended into sealing engagement therewith. The use of such a luer lock allows monomer to be dispensed into tube 124 (and hence the mixing chamber 14 of the canister 12) while preventing monomer vapors from escaping between the monomer delivery device and the mixing device
10 (i.e. between luer of the delivery device and the luer lock of the mixing device).

It should be appreciated that such a luer lock may be configured to facilitate a "slip fit" type of sealing arrangement, or, alternately, may be configured to facilitate a threaded coupling with the corresponding
15 mechanism of the monomer delivery device. Moreover, a combination coupling mechanism may be utilized which facilitates mating with both threaded and non-threaded couplings.

A cap 128 is provided to selectively seal the delivery port 122. Specifically, the cap 128 may be sealing received into the delivery port
20 122 in order to seal the delivery port 122 in a manner which prevents vapors or the like from escaping therefrom. A tether 130 extends between the crank 40 and the cap 128 in order to movably secure the cap 128 to the crank 40.

As alluded to above, the cap 128 is used to seal delivery port 122 after the monomer has been dispensed into mixing chamber 14 during the mixing process. The cap 128 is shown in a disengaged position in FIG. 7 in anticipation of the coupling of the monomer delivery device (not shown) with the delivery port 122 for the purpose of delivering monomer from the monomer delivery device into the mixing chamber 14. It will be appreciated that a variety of luer locks and luer lock caps may be used in the present invention. For example, a self-closing luer lock may be used thereby eliminating the need for luer cap 128 or, as described above, a threaded luer lock may be used to screw the cap 128 onto the body of the crank 40. In another embodiment, the monomer delivery device itself may be used as a seal for the luer lock. In yet another embodiment, the luer cap 128 may be replaced with a paper-backed piece of re-sealable tape or the like which may be removed to allow for mating with the monomer delivery device, and then replaced when the monomer delivery device is detached.

Referring now to FIG. 9, the lower gear housing 38 has a vacuum port 132 defined therein (see also FIG. 1). A vacuum source (not shown) may be fluidly coupled to the vacuum port 132 in order to draw air from the mixing chamber 14 of the mixing device 10. The introduction of a vacuum is useful during the aforescribed introduction of the liquid cement component into the mixing chamber 14 since the presence of lower pressure within the chamber 14 tends to draw the liquid (i.e. the

monomer) through the fluid orifices 120 of the shaft 104 and into the mixing chamber 14. Moreover, the presence of the vacuum also removes vapors and the like from the mixing device 10 thereby further reducing the occasions in which such vapors escape from the device 10.

5 As shown in FIG. 7, 9, 18-22, the mixing device 10 also includes a blade wiping member or diaphragm 134. The blade wiping diaphragm 134 is preferably constructed of an elastomeric material. The blade wiping diaphragm 134 has a number of vane receiving slots 136 and a shaft receiving opening 138 defined therein. As will now be described in
10 greater detail, the blade wiping diaphragm 134 is provided to "wipe" or otherwise remove residual bone cement from the mixing blade 52 during removal thereof from the mixing chamber 14. As such, the blade wiping diaphragm 134 may be configured to include any number, size, or shape of vane receiving slots 136 in order to accommodate a given design of a
15 mixing blade 52.

Once the liquid bone cement component (e.g. the monomer) and the powder bone cement component have been thoroughly mixed with one another, the lower gear housing 38 is unscrewed from the cartridge 16 so that the mixing head assembly 30 may be removed from the
20 cartridge 16 thereby allowing a delivery nozzle assembly 150 (see FIGS. 23 and 24) to be screwed onto the cartridge 16 in its place. During such removal of the mixing head assembly 30, as shown in FIG. 19, the vanes 116 of the mixing blade 52 are advanced through the vane receiving slots

136 of the blade wiping diaphragm 134. Such advancement of the vanes 116 through the vane receiving slots 136 wipes or otherwise removes any residual bone cement from the vanes 116 thereby preventing such residual bone cement from being wasted (i.e. removed from the mixing chamber 14, but not utilized in the surgical procedure).

In order to provide for proper alignment of the vanes 116 of the mixing blade 52 with the vane receiving slots 136, the blade wiping diaphragm 134 is rotatably secured to the cartridge 16. In particular, as show in FIG. 18, the cartridge 16 includes a number of retaining members or snaps 140. An outer peripheral edge 142 of the blade wiping diaphragm 134 is positioned under the snaps 140 in order to secure the diaphragm 134 to the cartridge 16 during securement of the mixing head assembly 30 to the cartridge 16. Moreover, the mixing blade 52 is preferably configured to include a number of protrusions or "wings" 144 which extend outwardly from the shaft 104 (see FIGS. 21 and 22). The wings 144 are aligned with the vanes 116 and are therefore positioned in the vane receiving slots 136 as shown in FIGS. 21 and 22. As such, rotation of the mixing blade 52, and therefore the wings 144, causes similar rotation of the blade wiping diaphragm 134.

Moreover, the wings 144 also function to retain the blade wiping diaphragm 134 on the mixing blade 52 prior to securement of the mixing head assembly 30 to the cartridge 16. In particular, the blade wiping diaphragm 134 is initially secured to the wings 144 of the mixing blade 52

prior to use of the mixing device 10. In such a manner, as shall be discussed below in greater detail, the powder bone cement component may be poured or otherwise advanced into the open end (i.e. the upper end 20) of the cartridge 16. Once the powder component has been

5 poured into the open end of the cartridge 16, the mixing head assembly 30 is screwed onto the threads 22 of the upper end 20 of the cartridge 16. As the mixing head is screwed onto the upper end 20 of the cartridge 16, the outer peripheral edge 142 of the blade wiping diaphragm 134 is pressed or otherwise advanced under each of the snaps 140 in order to

10 secure the diaphragm 134 to the cartridge 16. As shall be discussed below in greater detail, such positioning of the outer peripheral edge 142 of the blade wiping diaphragm 134 under the snaps 140 allows for retention of the blade wiping diaphragm 134 during subsequent removal of the mixing head assembly 30.

15 It should be appreciated that the configuration of the mixing device 10 in which the blade wiping diaphragm 134 is rotated in concert with the mixing blade 52 reduces the number of vane receiving slots 136 that must be included in the construction of the blade wiping diaphragm 134. Specifically, since the wings 144 are retained in the slots 136, the vanes

20 116 (which are aligned with the wings 144) are likewise at all times aligned with the vane receiving slots 136. Hence, at any given time, the mixing blade 52 may be removed by pulling the vanes 116 of the blade 52 through the vane receiving slots 136. Such a reduction in the number of

vane receiving slots 136 facilitates ease of manufacture of the blade wiping diaphragm 134.

As shown in FIG. 22, the shaft 104 of the mixing blade 52 also has an upper shoulder 146 and a lower shoulder 148 defined therein. As shown in FIG. 22, the body of blade wiping diaphragm 134 is captured or otherwise positioned between the upper shoulder 146 and the lower shoulder 148. The upper shoulder 146 is greater in diameter than the lower shoulder 148. The upper shoulder prevents upward movement of the blade wiping diaphragm 134. The lower shoulder 148, on the other hand, is somewhat smaller in diameter and includes a number of rounded edges. In such a manner, the lower shoulder 148 supports the blade wiping diaphragm 134 in its desired position, but also allows for removal of the mixing blade 52 since the lower shoulder may advance through the shaft receiving opening 138 of the blade wiping diaphragm 134 during removal of the blade 52.

As alluded to above, once the liquid cement component and the powder cement component have been thoroughly mixed, the mixing device 10 of the present invention may be utilized to deliver the mixed bone cement. In particular, as shown in FIGS. 23-25, once the liquid bone cement component (e.g. the monomer) and the powder bone cement component have been thoroughly mixed with one another, the lower gear housing 38 is unscrewed from the cartridge 16 so that the mixing head assembly 30 may be removed from the cartridge 16.

Thereafter, the delivery nozzle assembly 150 may be screwed onto the threads 22 of the upper end 20 of the cartridge 16. The nozzle assembly 150 includes a nozzle 152 and an elongated tube 154. It should be appreciated that the length and/or diameter of the elongated tube 154
5 may be varied in order to fit the requirements of a given delivery application. Moreover, it should also be noted that in certain situations, it may be desirable to dispense (i.e. delivery) the mixed bone cement directly through the nozzle 152 without the use of the elongated tube 154.

In any event, once the nozzle assembly 150 has been secured to
10 the canister 12, the lower end 24 of the cartridge 18 is unscrewed from the base 34 thereby separating the canister 12 from the base 34. Such removal of the base 34 also exposes a bottom surface 156 of the plunger 110 (see FIG. 7). The canister 12 may then be placed in the chamber of a delivery gun mechanism (not shown) much in the same way as a tube of
15 caulk is placed in a household caulk gun. As the operator squeezes the trigger (not shown) or otherwise actuates the gun mechanism, a contact member (not shown) urges the plunger 110 in the general direction toward the nozzle assembly 150. Such movement of the plunger 110 forces the mixed bone cement within the mixing chamber 14 through the
20 openings defined in the blade wiping diaphragm 134 (i.e. the vane receiving slots 136 and the shaft receiving opening 138) and then through the nozzle 152 and tube 154 of the nozzle assembly.

Operation of the Present Invention

In operation, the bone cement mixing device 10 of the present invention is utilized to mix a liquid bone cement component with a powder bone cement component and thereafter deliver the mixed bone cement to a desired location during performance of a surgical procedure. In order to do so, the powder bone cement component is first placed in the mixing chamber 14 of the canister 12. In particular, with the mixing head assembly 30 removed from the canister 12, a quantity of the powder bone cement component is poured or otherwise advanced into the open end of the cartridge 16 (i.e. the upper end 20 of the cartridge 16) and hence into the mixing chamber 14 of the canister 12. As discussed above, the canister 12 is preferably configured to accommodate (i.e. hold) at least 120 grams (e.g. three batches of 40 grams each) of powder bone cement.

Once the powder bone cement component has been placed in the canister 12, the mixing head 30 is screwed onto the upper end 20 of the cartridge 16. In particular, as shown in FIG. 7, the threads 28 of the lower gear housing 38 are threadingly advanced onto the threads 22 of the upper end 20 of the cartridge 16 until the mixing head 30 is fully secured to the canister 12. As discussed above, as the mixing head assembly is screwed onto the upper end of the cartridge 16, the O-ring 158 is compressed thereby sealing the mixing head 30 to the canister 12 (see FIG. 19).

Moreover, during such attachment of the mixing head 30 to the canister 12, the blade wiping diaphragm 134 (which is secured to the wings 144 of the mixing blade 52) is secured to the canister 12. In particular, as the mixing head assembly 30 is screwed onto the canister 5 12, the outer peripheral edge 142 of the blade wiping diaphragm 134 is pressed or otherwise advanced under the snaps 140 of the cartridge 16 thereby securing the diaphragm 134 to the cartridge 16.

Once the mixing head assembly 30 is sealingly secured to the canister 12 in such a manner, the liquid bone cement component (e.g. the 10 monomer) may be advanced into the mixing chamber 12 and hence into contact with the powder bone cement component positioned therein. In particular, as shown in FIG. 7, the port cap 128 is first removed from sealing engagement with the monomer delivery port 122 in order to permit fluid access to the mixing chamber 14 of the canister 12. Thereafter, the 15 required quantity of liquid cement component may be introduced into the mixing chamber 14 of the canister 12 through the delivery port 122.

Specifically, an outlet coupling of a monomer delivery device (not shown) is first sealingly coupled to the monomer delivery port 122 of the mixing device 10. Thereafter, the liquid cement component (e.g. the monomer) 20 contained in the monomer delivery device is introduced into the mixing chamber 14 via the fluid path which includes the delivery port 122, the tube 124, the fluid passageway 118 of the shaft 104, and the fluid orifices 120 of the shaft 104. In such a manner, the monomer is delivered at

various locations throughout the depth of the powder component present in the mixing chamber 14. In particular, since fluid orifices 120 are provided at a number of different locations along the length of the shaft 104, the liquid component (e.g. the monomer) is delivered at locations throughout the height of the canister 12 thereby allowing the liquid to be interspersed throughout the depth of the powder component present in the mixing chamber 12.

It should be appreciated that since the monomer delivery port 122 is preferably embodied as a luer lock or other type of sealable component, and therefore "mated" with a similar type of outlet coupling on the monomer delivery device, the monomer is dispensed into the tube 124 (and hence the mixing chamber 14 of the canister 12) while preventing monomer vapors from escaping between the monomer delivery device and the mixing device 10 (e.g. between luer of the monomer delivery device and the luer lock of the mixing device 10).

It should be appreciated that, as described above, it may be desirable to introduce the monomer into the mixing chamber 14 of the canister 12 in the presence of a vacuum within chamber 14. In such a case, a vacuum source (not shown) is fluidly coupled to the vacuum port 132 of the lower gear housing 38 of the mixing head assembly 30 in order to draw air from the mixing chamber 14 of the mixing device 10. The introduction of a vacuum is useful during the aforescribed introduction of the liquid cement component into the mixing chamber 14 since the

presence of lower pressure within the chamber 14 tends to draw the liquid (i.e. the monomer) through the fluid orifices 120 of the shaft 104 and into the mixing chamber 14. Moreover, the presence of the vacuum also removes vapors and the like from the mixing device 10 thereby further
5 reducing the occasions in which such vapors escape from the device 10. However, in certain applications, it may be desirable to introduce the liquid monomer into the mixing chamber 14 without the presence of a vacuum within the canister 12.

In any event, after the monomer has been dispensed into mixing
10 chamber 14 in the manner described above, the cap 128 is positioned back in sealing engagement within the delivery port 122 so as to prevent the escape of any vapors associated with the delivered monomer.

Thereafter, the operator may commence to mix the liquid cement component and the powder cement component with one another.

15 Specifically, the operator grips the outer surface of the canister 12 with one hand while gripping the knob 44 of the crank 40 with the other hand. The operator then rotates the crank 40 in either a clockwise or counterclockwise direction. Such rotation of the crank 40 drives the gear train 46 of the mixing head assembly 30. As described in detail above,
20 the gear train 46 of the present invention is configured such that the direction of rotation of the output pinion 48 (and hence the mixing blade 52) alternates (i.e. changes) despite rotation of the crank 40 (and hence the directional gear 54) in only a single direction. Specifically, as shown

in FIGS. 12-17, as the idler gear 56 is engaged with the outer gear teeth 90 of the directional gear 54, the output pinion 48 and hence the mixing blade 52 is rotated in a first direction. However, as the idler gear disengages the outer gear teeth 90 and engages the inner gear teeth 86 of the directional gear 54, the direction of travel of the output pinion 48 and hence the mixing blade 52 is reversed thereby creating alternating or reciprocating motion.

Moreover, as described above in greater detail, since the relatively large number of individual gear teeth associated with the outer gear teeth 90 creates a relatively large gear ratio with the idler gear 56 relative to the gear ratio created by inner gear teeth 86 and the idler gear 56, varying angular distances of travel and speeds of the mixing blade 52 are created. For example, in the case of the exemplary embodiment described herein, as the operator advances the crank 40 through an entire revolution (i.e. 360° of rotation), the mixing blade 52 is driven across 540° of rotation in a first direction and then reversed and driven across 135° of rotation in the opposite direction. Moreover, in such an exemplary embodiment, when as the operator advances the crank 40 through such an entire revolution (i.e. 360° of rotation), the mixing blade 52 is driven three times as quickly in the first direction as it is when reversed and driven in the opposite direction. Such a reciprocating movement of the mixing blade 52 (i.e. at varying angular distances and speeds) creates desirable "agitation" within the mixing chamber 14 of the

canister 12 which increases the mix quality of the mixing device 10 by reducing, if not eliminating, the amount of the powder component bone cement which is not thoroughly mixed with the liquid component of the bone cement.

5 Moreover, as described above in greater detail, during such movement (i.e. rotation) of the mixing blade 52, the blade wiping diaphragm 134 is likewise rotated. In particular, in order to provide for proper alignment of the vanes 116 of the mixing blade 52 with the vane receiving slots 136 of the blade wiping diaphragm 134 during subsequent
10 removal of the mixing head assembly 30 from the canister 12, the blade wiping diaphragm 134 is rotatable relative to the cartridge 16. Specifically, as show in FIG. 18, the outer peripheral edge 142 of the blade wiping diaphragm 134 is positioned under the snaps 140 in order to secure the diaphragm 134 to the cartridge 16 in a manner which allows
15 the diaphragm to rotate relative to the cartridge 16. The wings 144 of the mixing blade 52 are positioned in the vane receiving slots 136 thereby causing the blade wiping diaphragm 134 to be rotated in concert with the mixing blade 52.

 Once the liquid bone cement component (e.g. the monomer) and
20 the powder bone cement component have been thoroughly mixed with one another, the mixing head assembly 30 is removed from the canister 12. In particular, the lower gear housing 38 is unscrewed from the cartridge 16 so that the mixing head assembly 30 may be removed from

the cartridge 16 thereby allowing the delivery nozzle assembly 150 (see FIGS. 23 and 24) to be screwed onto the cartridge 16 in its place. During such removal of the mixing head assembly 30, as shown in FIG. 19, the vanes 116 of the mixing blade 52 are advanced through the vane receiving slots 136 of the blade wiping diaphragm 134. In particular, since the blade wiping diaphragm 134 is secured to the cartridge 16 by the snaps 140, the mixing blade 52 may be "pulled through" the openings (i.e. the vane receiving slots 136 and the shaft receiving opening 138) defined in the blade wiping diaphragm 134 without removing the blade wiping device. Such advancement of the vanes 116 through the vane receiving slots 136 wipes or otherwise removes any residual bone cement from the vanes 116 thereby preventing such residual bone cement from being wasted (i.e. removed from the mixing chamber 14, but not utilized in the surgical procedure).

The mixing device 10 of the present invention may be utilized to deliver the mixed bone cement. In particular, as shown in FIGS. 23-25, once the liquid bone cement component (e.g. the monomer) and the powder bone cement component have been thoroughly mixed with one another, the lower gear housing 38 is unscrewed from the cartridge 16 so that the mixing head assembly 30 may be removed from the cartridge 16. Thereafter, the delivery nozzle assembly 150 is screwed onto the threads 22 of the upper end 20 of the cartridge 16. The lower end 24 of the cartridge 18 is then unscrewed from the base 34 thereby separating the

canister 12 from the base 34. As described above and shown in FIG. 7, such removal of the base 34 also exposes the bottom surface 156 of the plunger 110. The canister 12 may then be placed in the chamber of a delivery gun mechanism (not shown) much in the same way as a tube of caulk is placed in a household caulk gun. As the operator squeezes the trigger (not shown) or otherwise actuates the gun mechanism, a contact member (not shown) urges the plunger 110 in the general direction toward the nozzle assembly 150. Such movement of the plunger 110 forces the mixed bone cement within the mixing chamber 14 through the openings defined in the blade wiping diaphragm 134 (i.e. the vane receiving slots 136 and the shaft receiving opening 138) and then through the nozzle 152 and tube 154 of the nozzle assembly 150 thereby delivering the mixed bone cement to a desired location.

Hence, as described herein, bone cement mixing device 10 of the present invention provide numerous advantages over heretofore designed mixing apparatus. For example, the alternating or reciprocating action of the mixing blade 52 enhances the quality of the mixed bone cement by reducing, if not eliminating, the amount of powder component which is not adequately mixed with the liquid component. Moreover, such alternating or reciprocating action is advantageously generated by rotation of the crank 40 in only a single direction and at a single speed. In particular, the configuration of the gear train 46 eliminates the need for the operator to manually reverse the direction of the crank 40 and/or manually alter the

speed at which the crank 40 is being rotated in order to produce the desired blade movement.

Yet further, the sealed relationship between the outlet coupling of the monomer delivery device and the delivery port 122 of the mixing device 10 provides for delivery and mixing of the bone cement without exposing the operator of the system to monomer vapors.

In addition, since the fluid orifices 120 of the mixing blade 52 are provided at a number of different locations along the length of the shaft 104, the liquid component (e.g. the monomer) is delivered at locations throughout the height of the canister 12 thereby allowing the liquid to be interspersed throughout the entire depth of the powder component present in the mixing chamber 12. As described above, this is a significant advantage over heretofore designed systems in which the monomer is poured or otherwise advanced through the lid of the mixing apparatus thereby only allowing the monomer to be introduced to the "top" of the powder within the mixing apparatus. Moreover, the structure of the present invention also provide advantages over heretofore designed system having a delivery path through the mixing shaft of the system which have an opening only at the bottom end of the shaft (similar to a common drinking straw). In such a configuration, the monomer only flows out of the bottom of the shaft and in some cases may be restricted by the plunger on which the lower end of the shaft rests.

While the invention has been illustrated and described in detail in the drawings and foregoing description, such an illustration and description is to be considered as exemplary and not restrictive in character, it being understood that only the preferred embodiments have
5 been shown and described and that all changes and modifications that come within the spirit of the invention are desired to be protected.

There are a plurality of advantages of the present invention arising from the various features of the bone cement mixing and delivery device and associated method described herein. It will be noted that alternative
10 embodiments of the bone cement mixing and delivery device and associated method of the present invention may not include all of the features described yet still benefit from at least some of the advantages of such features. Those of ordinary skill in the art may readily devise their own implementations of a bone cement mixing and delivery device and
15 associated method that incorporate one or more of the features of the present invention and fall within the spirit and scope of the present invention.

THE CLAIMS DEFINING THE INVENTION ARE AS FOLLOWS:

1. A bone cement mixing apparatus, comprising:

a handle;

5 an input gear which is caused to rotate about a central axis in response to rotation of said handle, wherein (i) said input gear includes a first input gear teeth set and a second input gear teeth set, (ii) said first input gear teeth set is spaced a first radial distance from said central axis, (iii) said second input gear teeth set is spaced a second radial distance
10 from said central axis, (iv) said second radial distance is greater than said first radial distance, (v) said first input gear teeth set extends outwardly away from said central axis, and (vi) said second input gear teeth set extends inwardly toward said central axis;

an intermediate gear, wherein said input gear is configured so that
15 during rotation thereof (i) said first input gear teeth set meshingly engages said intermediate gear during a first period of time, and (ii) said second input gear teeth set meshingly engages said intermediate gear during a second period of time which is different from said first period of time;

20 an output gear which is caused to rotate in response to rotation of said intermediate gear; and

a mixing blade which is caused to rotate in response to rotation of said output gear.

2. The bone cement mixing apparatus of claim 1, further comprising:

a first gear housing portion; and

5 a second gear housing portion,

wherein a gear chamber is defined when said first gear housing portion is secured to said second gear housing portion,

wherein said input gear, said intermediate gear, and said output gear are positioned within said gear chamber, and

10 wherein said handle and said mixing blade are positioned outside of said gear chamber.

3. The bone cement mixing apparatus of claim 1, wherein:

said central axis lies in a plane which divides said input gear into a
15 first input gear side and a second input gear side,

said input gear is configured so that (i) said first input gear teeth set is positioned entirely on said first input gear side, and (ii) said second input gear teeth set is positioned entirely on said second input gear side.

20 4. The bone cement mixing apparatus of claim 1, wherein:

said mixing blade includes a shaft and a number of vanes extending outwardly from said shaft, and

said shaft is aligned with said central axis.

5. The bone cement mixing apparatus of claim 1, wherein said intermediate gear rotates about an offset axis which is spaced apart from said central axis.

5 6. The bone cement mixing apparatus of claim 2, wherein:
said intermediate gear rotates about an offset axis which is spaced apart from said central axis,

said second gear housing portion includes a post which is aligned with said offset axis, and

10 said intermediate gear includes an aperture which receives said post so as to rotatably couple said intermediate gear to said second gear housing portion.

7. The bone cement mixing apparatus of claim 1, wherein said
15 intermediate gear meshingly engages said output gear.

8. The bone cement mixing apparatus of claim 1, wherein said output gear is caused to rotate about said central axis in response to rotation of said intermediate gear.

20

9. The bone cement mixing apparatus of claim 1, wherein said input gear is non-rotatably secured to said handle.

10. The bone cement mixing apparatus of claim 1, wherein:
said input gear has a ring-shaped slot defined therein,
said intermediate gear includes a post which is received within said
ring-shaped slot,

5 said post is located in said slot during rotation of said input gear.

11. The bone cement mixing apparatus of claim 1, wherein:
said intermediate gear is driven in a first direction of rotation during
said first period of time,

10 said intermediate gear is driven in a second direction of rotation
during said second period of time, and

 said first direction of rotation is opposite to said second direction of
rotation.

15 12. The bone cement mixing apparatus of claim 11, wherein said
input gear travels in said second direction of rotation during both said first
period of time and said second period of time.

13. The bone cement mixing apparatus of claim 1, wherein:
said intermediate gear is driven to rotate at a first angular velocity
during said first period of time,

said intermediate gear is driven to rotate at a second angular
5 velocity during said first period of time, and
said first angular velocity is less than said second angular velocity.

14. The bone cement mixing apparatus of claim 1, wherein:
said intermediate gear is driven to rotate at a first output angular
10 velocity in response to said input gear being rotated at an input angular
velocity,

said intermediate gear is driven to rotate at a second output
angular velocity in response to said input gear being rotated at said input
angular velocity, and
15 said first angular velocity is less than said second angular velocity.

15. The bone cement mixing apparatus of claim 1, wherein:
in response to said input gear being rotated one revolution in a
clockwise direction of rotation, said intermediate gear is driven (i) a first
20 rotational distance in a counterclockwise direction of rotation, and (ii) a
second rotational distance in a clockwise direction of rotation, and
said first rotational distance is less than said second rotational
distance.

16. The bone cement mixing apparatus of claim 15, wherein:
said intermediate gear meshingly engages said output gear, and
said output gear is non-rotatably coupled to said mixing blade.

5 17. A bone cement mixing apparatus, comprising:
a handle;
an input gear which is caused to rotate in response to rotation of
said handle,
an intermediate gear which is caused to rotate in response to
10 rotation of said input gear;
an output gear which is caused to rotate in response to rotation of
said intermediate gear; and
a mixing blade which is caused to rotate in response to rotation of
said output gear,
15 wherein, in response to said input gear being rotated one
revolution, said intermediate gear is driven (i) a first rotational distance in
a counterclockwise direction of rotation, and (ii) a second rotational
distance in a clockwise direction of rotation, and
wherein said first rotational distance is less than said second
20 rotational distance.

18. The bone cement mixing apparatus of claim 17, wherein:
said intermediate gear meshingly engages said output gear, and
said output gear is non-rotatably coupled to said mixing blade.

5 19. The bone cement mixing apparatus of claim 17, further
comprising:

a first gear housing portion; and

a second gear housing portion,

10 wherein a gear chamber is defined when said first gear housing
portion is secured to said second gear housing portion,

wherein said input gear, said intermediate gear, and said output
gear are positioned within said gear chamber, and

15 wherein said handle and said mixing blade are positioned outside
of said gear chamber.

20 20. The bone cement mixing apparatus of claim 17, wherein said
input gear is non-rotatably secured to said handle.

21. A bone cement mixing apparatus, comprising:

a handle;

an input gear which is caused to rotate in response to rotation of
said handle.

5 an intermediate gear which is caused to rotate in response to
rotation of said input gear;

an output gear which is caused to rotate in response to rotation of
said intermediate gear; and

10 a mixing blade which is caused to rotate in response to rotation of
said output gear,

wherein said intermediate gear is driven to rotate at a first output
angular velocity during a first period of time in response to said input gear
being rotated at an input angular velocity,

15 wherein said intermediate gear is driven to rotate at a second
output angular velocity during a second period of time in response to said
input gear being rotated at said input angular velocity,

wherein said first angular velocity is less than said second angular
velocity, and

20 wherein said first period of time is different from said second period
of time.

22. The bone cement mixing apparatus of claim 21, wherein:
said intermediate gear is driven in a first direction of rotation during
said first period of time, and
said intermediate gear is driven in a second direction of rotation
5 during said second period of time,
wherein said first direction of rotation is opposite to said second
direction of rotation.

23. The bone cement mixing apparatus of claim 21, wherein:
10 said intermediate gear meshingly engages said output gear, and
said output gear is non-rotatably coupled to said mixing blade.

24. The bone cement mixing apparatus of claim 21, further
comprising:
15 a first gear housing portion; and
a second gear housing portion,
wherein a gear chamber is defined when said first gear housing
portion is secured to said second gear housing portion,
wherein said input gear, said intermediate gear, and said output
20 gear are positioned within said gear chamber, and
wherein said handle and said mixing blade are positioned outside
of said gear chamber.

25. The bone cement mixing apparatus of claim 21, wherein said input gear is non-rotatably secured to said handle.

26. A bone cement mixing apparatus, comprising:

5 an input gear which is configured to rotate about a central axis, wherein (i) said input gear includes a first input gear teeth set and a second input gear teeth set which are spaced apart from each other, and (ii) said first input gear teeth set extends outwardly away from said central axis, and (iii) said second input gear teeth set extends inwardly toward
10 said central axis;

an intermediate gear, wherein said input gear is configured so that during rotation thereof (i) said first input gear teeth set meshingly engages said intermediate gear during a first period of time, and (ii) said second input gear teeth set meshingly engages said intermediate gear
15 during a second period of time which is different from said first period of time; and

a mixing blade which is caused to rotate in response to rotation of said intermediate gear.

27. The bone cement mixing apparatus of claim 26, further comprising an output gear, wherein:

said output gear is caused to rotate in response to rotation of said intermediate gear, and

5 said mixing blade which is caused to rotate in response to rotation of said intermediate gear.

28. The bone cement mixing apparatus of claim 27, wherein:

said intermediate gear meshingly engages said output gear, and

10 said output gear is non-rotatably coupled to said mixing blade.

29. The bone cement mixing apparatus of claim 26, further comprising:

a first gear housing portion; and

15 a second gear housing portion,

wherein a gear chamber is defined when said first gear housing portion is secured to said second gear housing portion,

wherein said input gear and said intermediate gear are positioned within said gear chamber, and

20 wherein said mixing blade is positioned outside of said gear chamber.

30. The bone cement mixing apparatus of claim 26, further comprising a handle, wherein said input gear is caused to rotate about said central axis in response to rotation of said handle.

5 31. The bone cement mixing apparatus of claim 26, wherein:
said central axis lies in a plane which divides said input gear into a first input gear side and a second input gear side,
said input gear is configured so that (i) said first input gear teeth set is positioned entirely on said first input gear side, and (ii) said second
10 input gear teeth set is positioned entirely on said second input gear side.

32. The bone cement mixing apparatus of claim 26, wherein:
said mixing blade includes a shaft and a number of vanes extending outwardly from said shaft, and
15 said shaft is aligned with said central axis.

33. The bone cement mixing apparatus of claim 26, wherein said intermediate gear rotates about an offset axis which is spaced apart from said central axis.

20

34. The bone cement mixing apparatus of claim 29, wherein:
said intermediate gear rotates about an offset axis which is spaced
apart from said central axis,

said second gear housing portion includes a post which is aligned
5 with said offset axis, and

said intermediate gear includes an aperture which receives said
post so as to rotatably couple said intermediate gear to said second gear
housing portion.

10 35. The bone cement mixing apparatus of claim 27, wherein said
output gear is caused to rotate about said central axis in response to
rotation of said intermediate gear.

36. The bone cement mixing apparatus of claim 30, wherein said
15 input gear is non-rotatably secured to said handle.

37. The bone cement mixing apparatus of claim 26, wherein:
said input gear has a ring-shaped slot defined therein,
said intermediate gear includes a post which is received within said
20 ring-shaped slot,
said post is located in said slot during rotation of said input gear.

38. The bone cement mixing apparatus of claim 26, wherein:
said intermediate gear is driven in a first direction of rotation during
said first period of time,
said intermediate gear is driven in a second direction of rotation
5 during said second period of time, and
said first direction of rotation is opposite to said second direction of
rotation.

39. The bone cement mixing apparatus of claim 38, wherein said
10 input gear travels in said second direction of rotation during both said first
period of time and said second period of time.

40. The bone cement mixing apparatus of claim 26, wherein:
said intermediate gear is driven to rotate at a first angular velocity
15 during said first period of time,
said intermediate gear is driven to rotate at a second angular
velocity during said second period of time, and
said first angular velocity is less than said second angular velocity.

41. The bone cement mixing apparatus of claim 26, wherein:
said intermediate gear is driven to rotate at a first output angular
velocity during said first period of time in response to said input gear
being rotated at an input angular velocity,

5 said intermediate gear is driven to rotate at a second output
angular velocity during said second period of time in response to said
input gear being rotated at said input angular velocity, and
said first angular velocity is less than said second angular velocity.

10 42. The bone cement mixing apparatus of claim 26, wherein:
in response to said input gear being rotated one revolution in a
clockwise direction of rotation, said intermediate gear is driven (i) a first
rotational distance in a counterclockwise direction of rotation, and (ii) a
second rotational distance in a clockwise direction of rotation, and

15 said first rotational distance is less than said second rotational
distance.

43. A bone cement mixing apparatus, comprising:

an input gear which is configured to rotate about a central axis,
wherein (i) said input gear includes a first input gear teeth set and a
second input gear teeth set which are spaced apart from each other, and
5 (ii) said first input gear teeth set extends outwardly away from said central
axis, and (iii) said second input gear teeth set extends inwardly toward
said central axis;

a slave gear which is caused to rotate in response to rotation of
said input gear; and

10 a mixing blade which is caused to rotate in response to rotation of
said slave gear.

44. The bone cement mixing apparatus of claim 43, wherein said
input gear is configured so that during rotation thereof (i) said first input
15 gear teeth set meshingly engages said slave gear during a first period of
time, and (ii) said second input gear teeth set meshingly engages said
slave gear during a second period of time which is different from said first
period of time.

45. The bone cement mixing apparatus of claim 43, wherein:
said central axis lies in a plane which divides said input gear into a
first input gear side and a second input gear side,

said input gear is configured so that (i) said first input gear teeth
5 set is positioned entirely on said first input gear side, and (ii) said second
input gear teeth set is positioned entirely on said second input gear side.

46. A bone cement mixing apparatus substantially as hereinbefore described
with reference to the accompanying drawings.

DePuy Products, Inc.

By Freehills Carter Smith Beadle

Registered Patent Attorneys for the Applicant

30 November 2001

FIG. 1

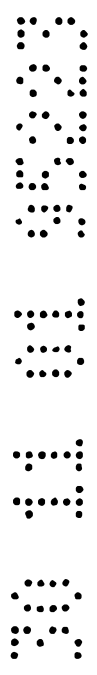
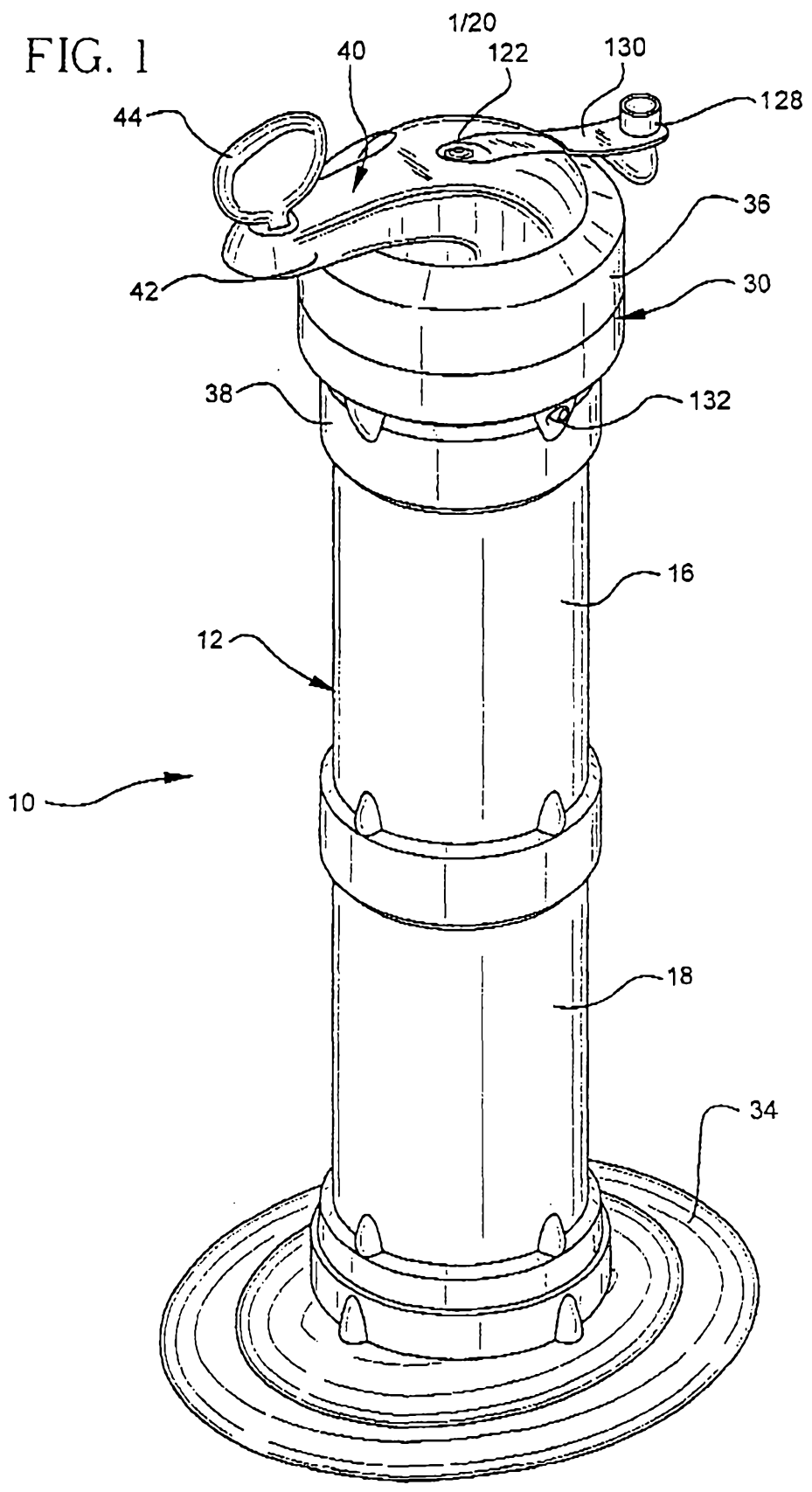

FIG. 2

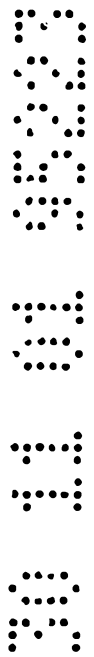
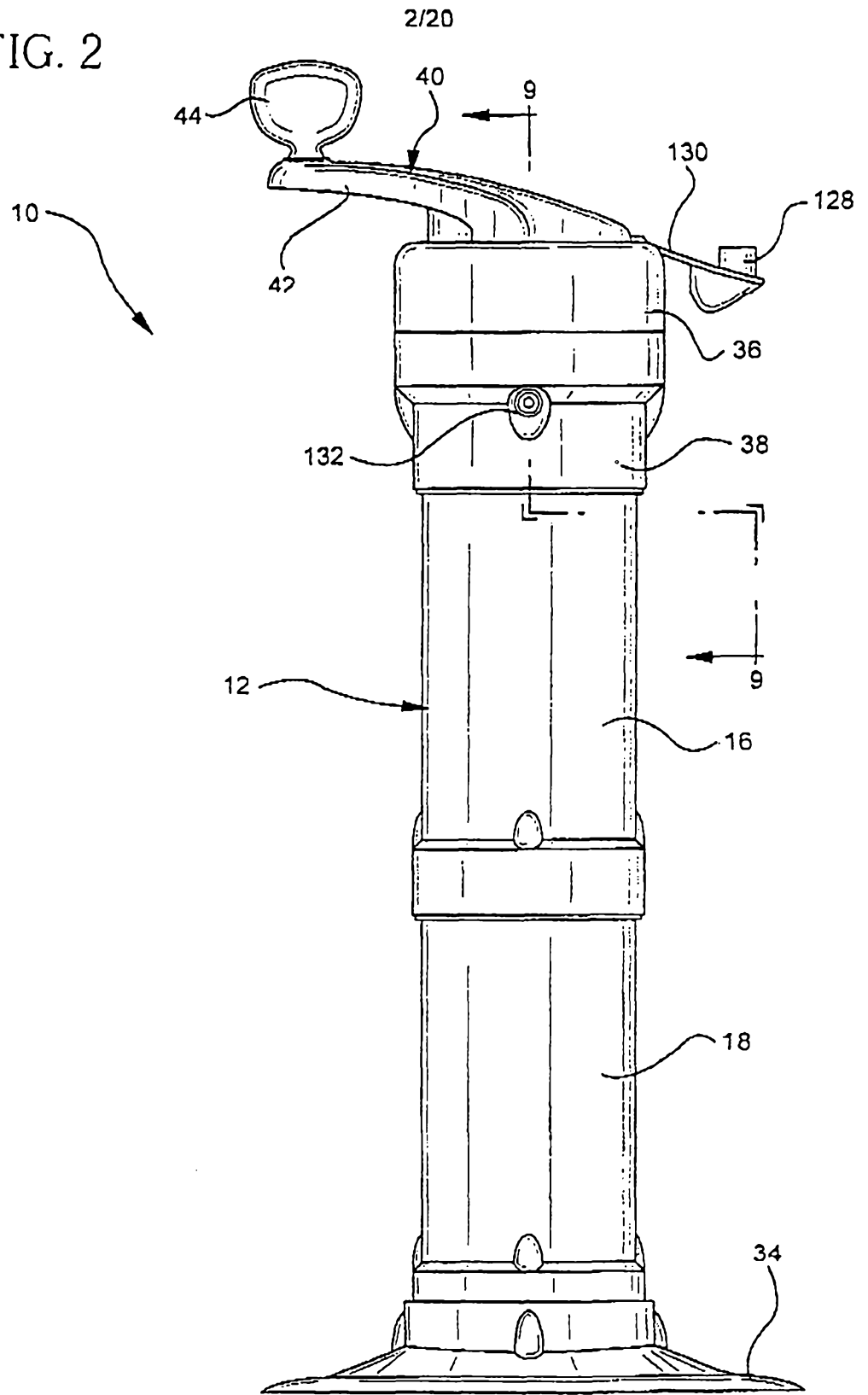

FIG. 3

3/20

10

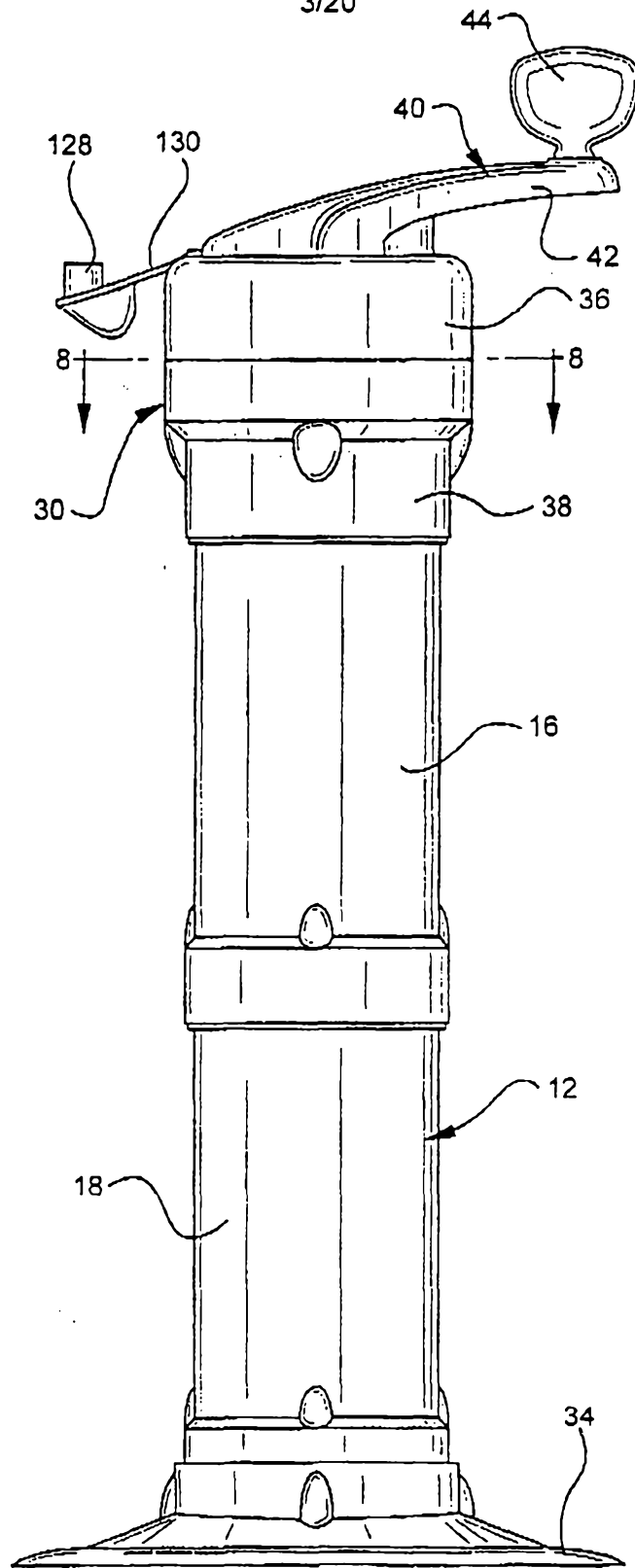

FIG. 4

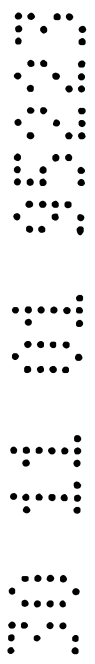
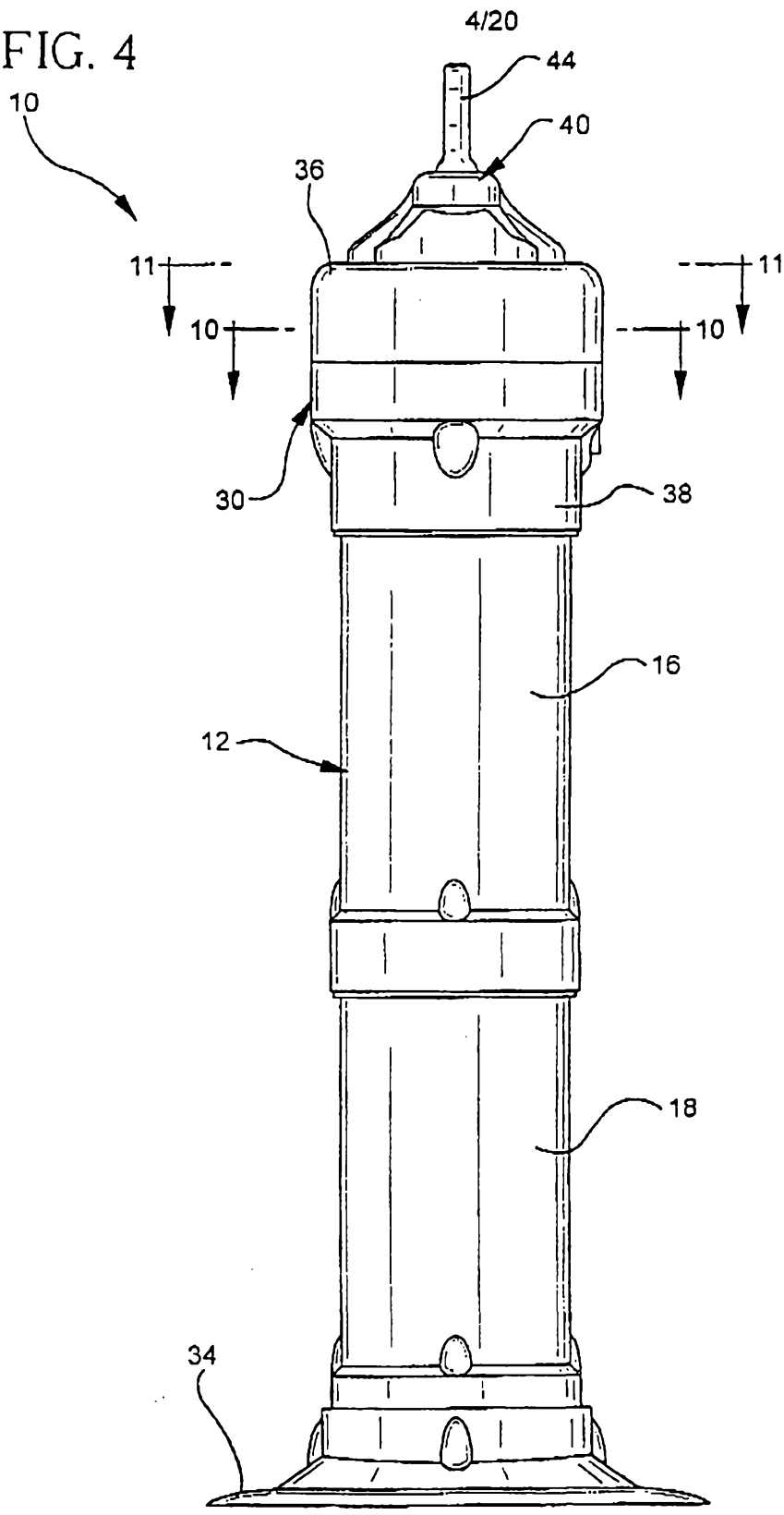
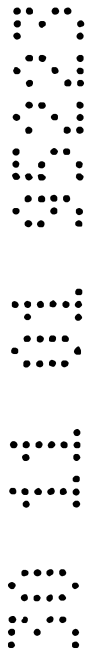
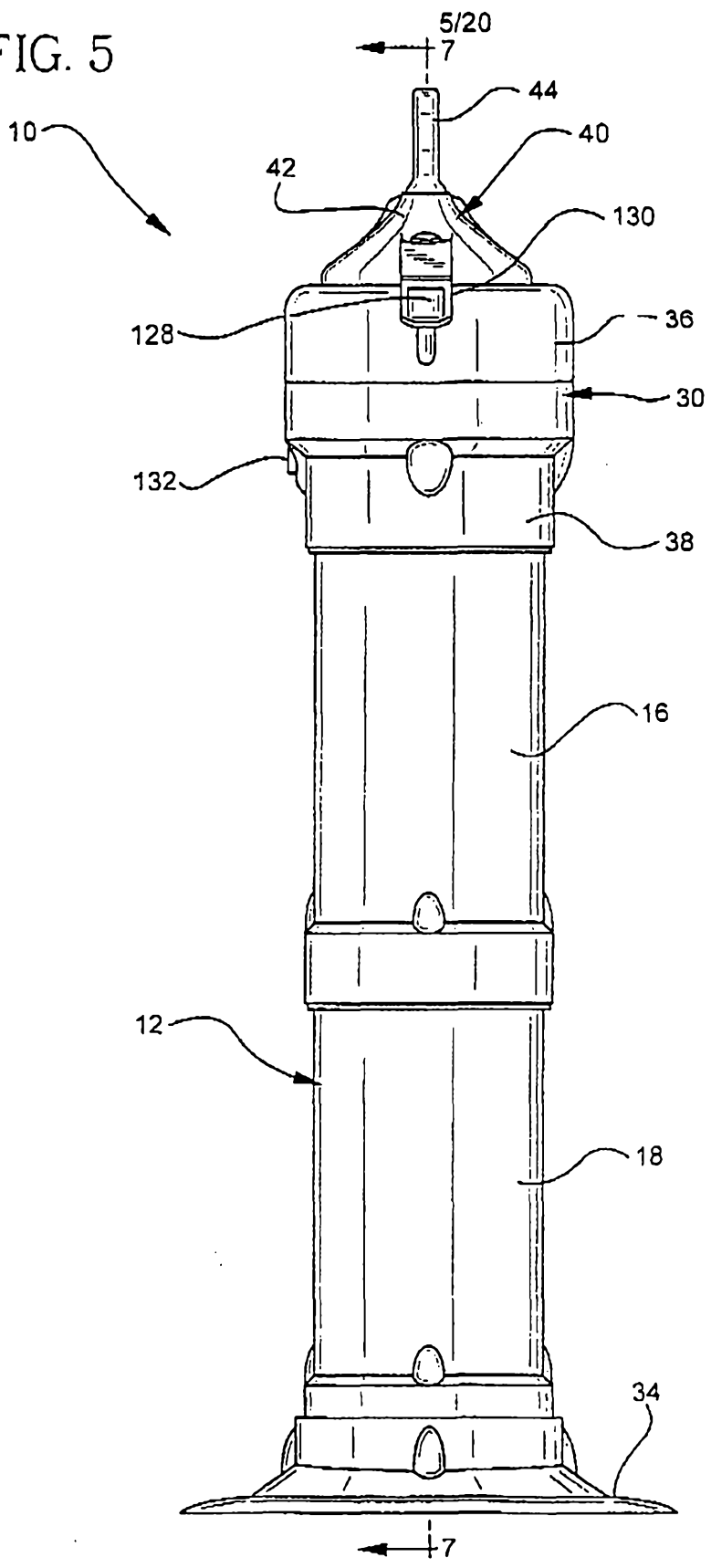

FIG. 5



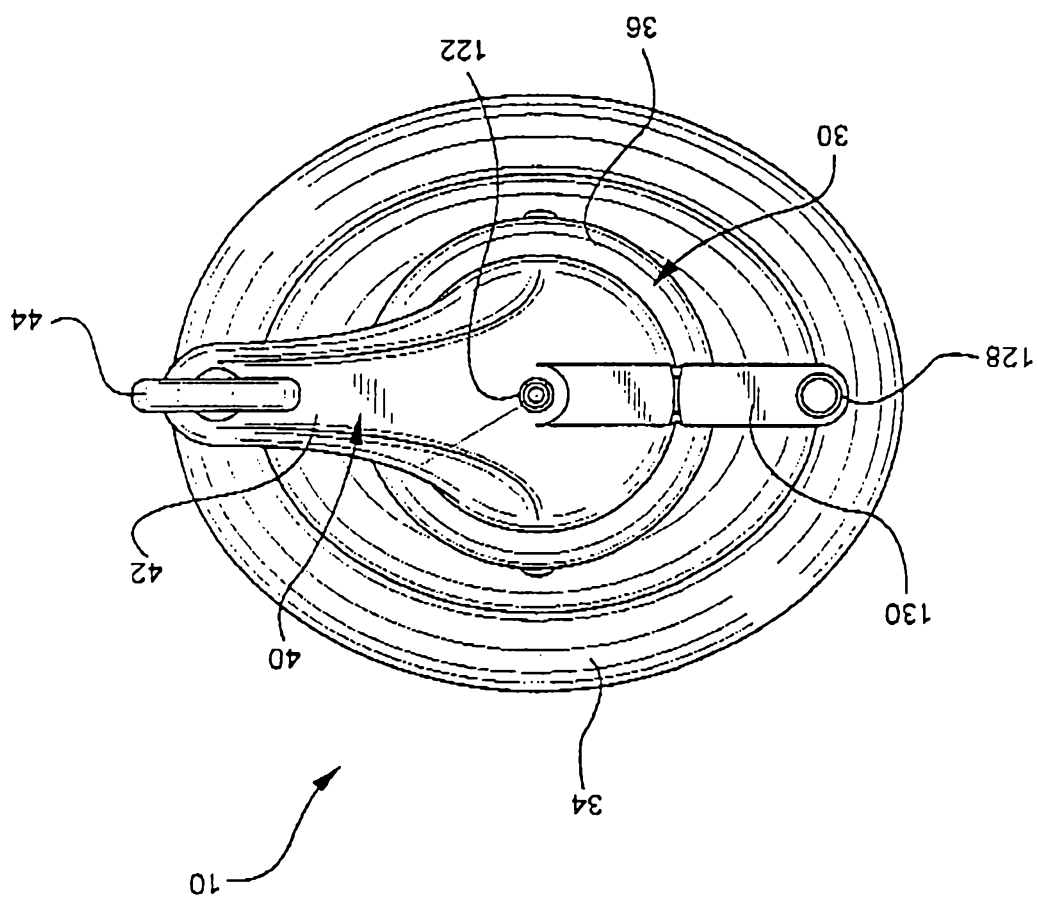

FIG. 6

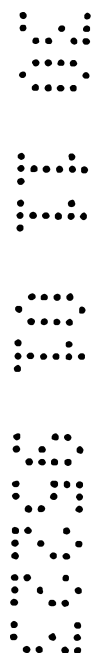

FIG. 7

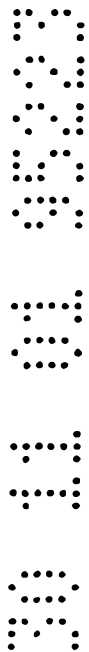
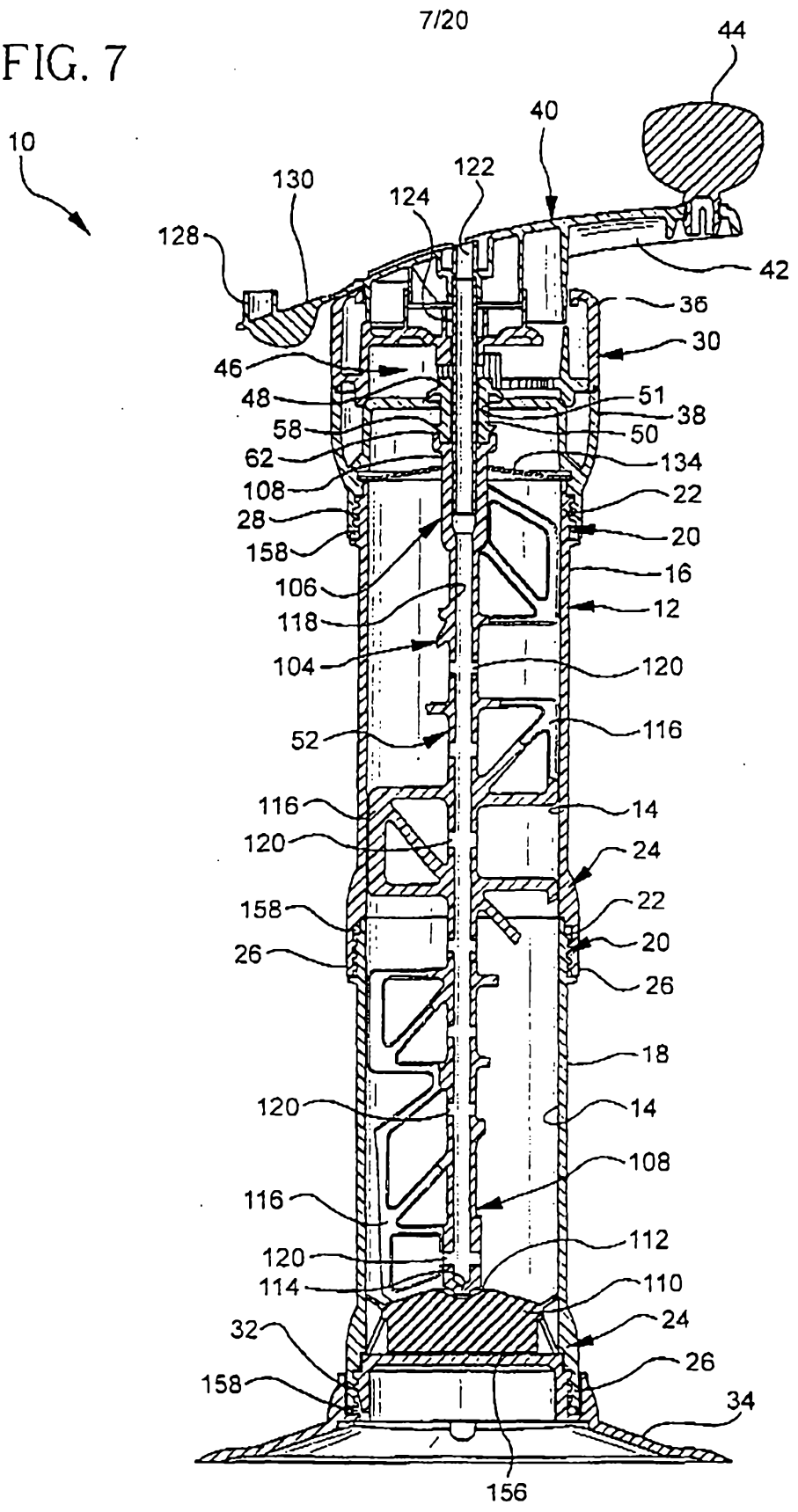

FIG. 8

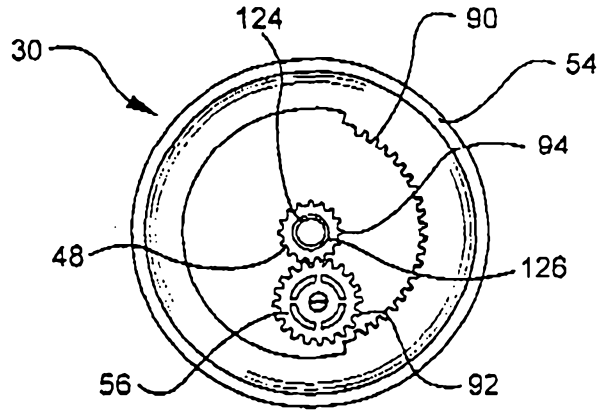

FIG. 9

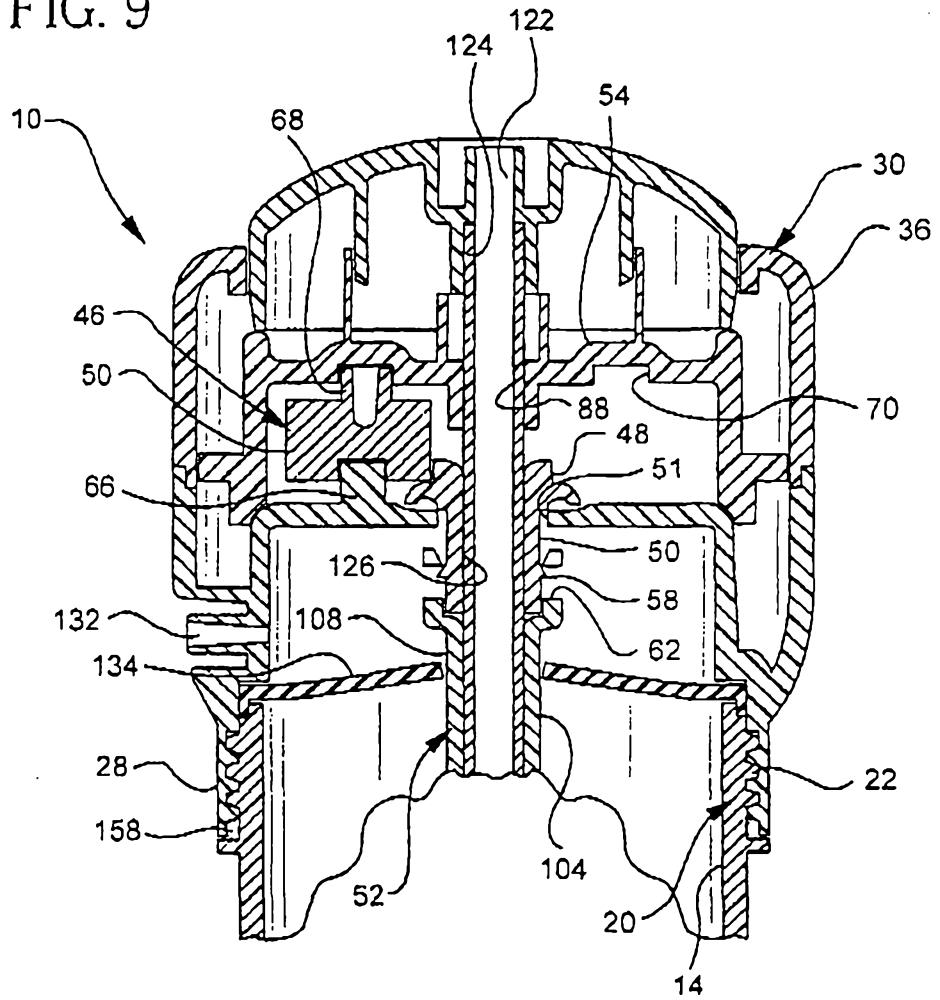

FIG. 10

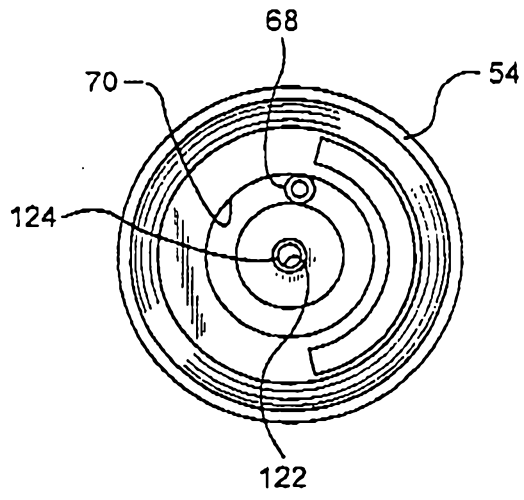

FIG. 11

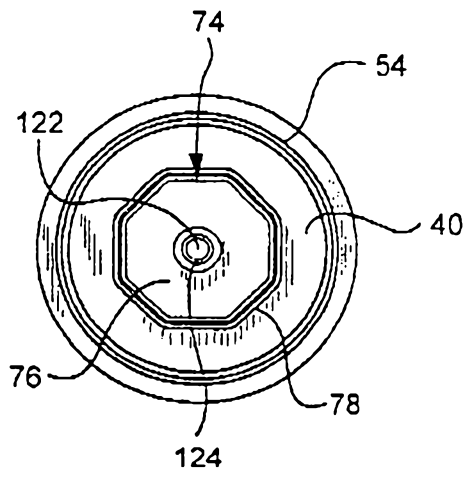

FIG. 12

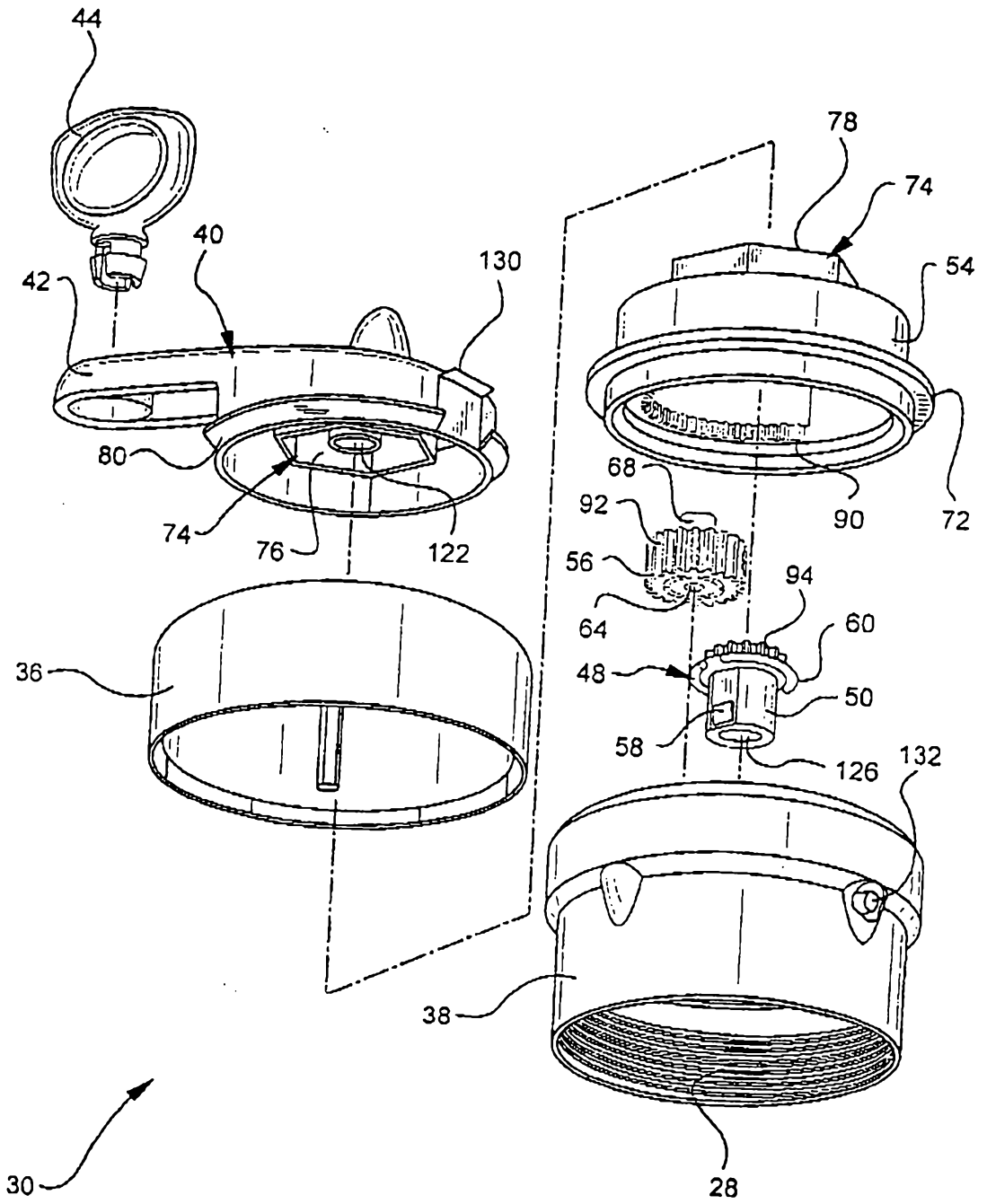

FIG. 13

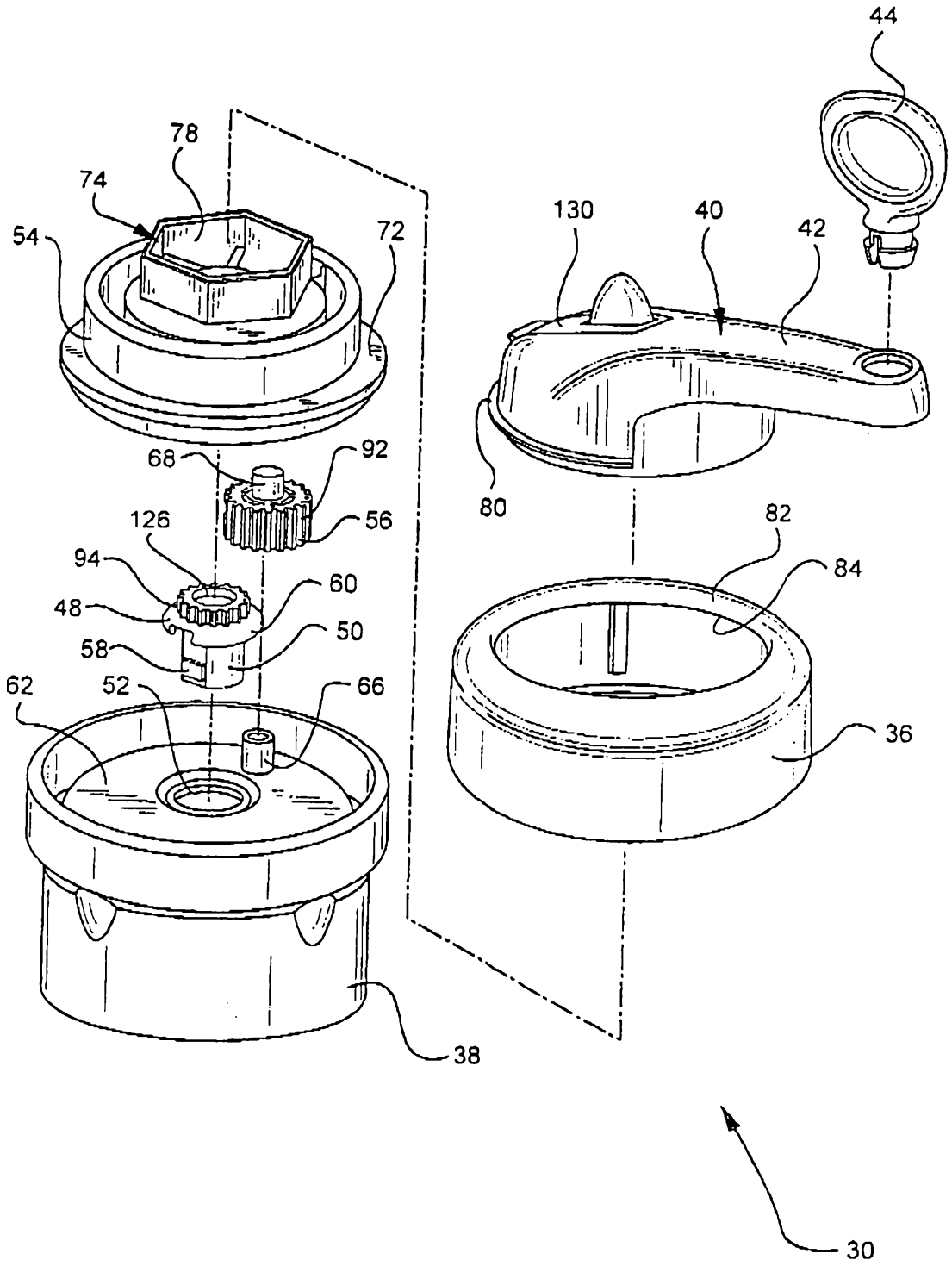

FIG. 14

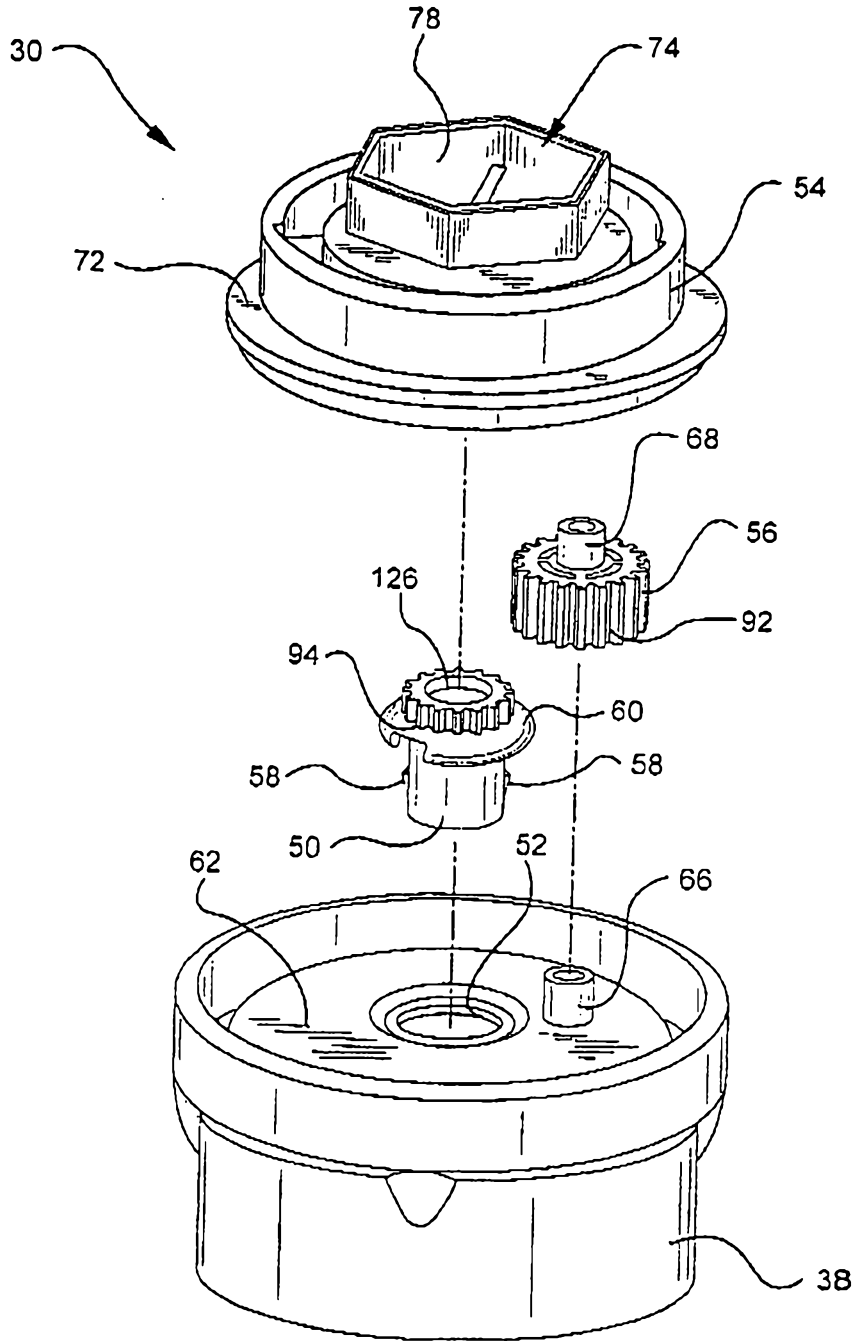

FIG. 15

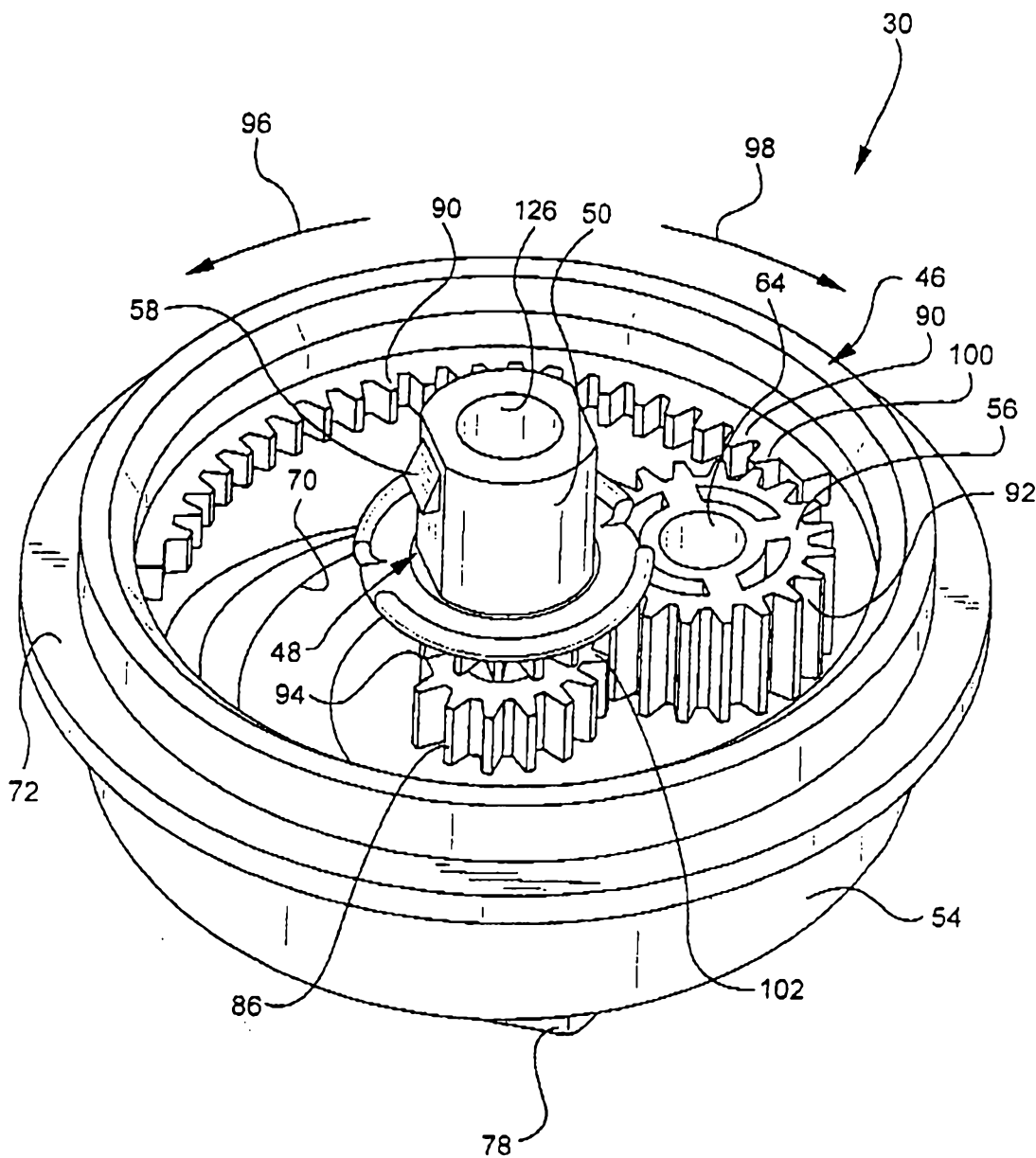

FIG. 16

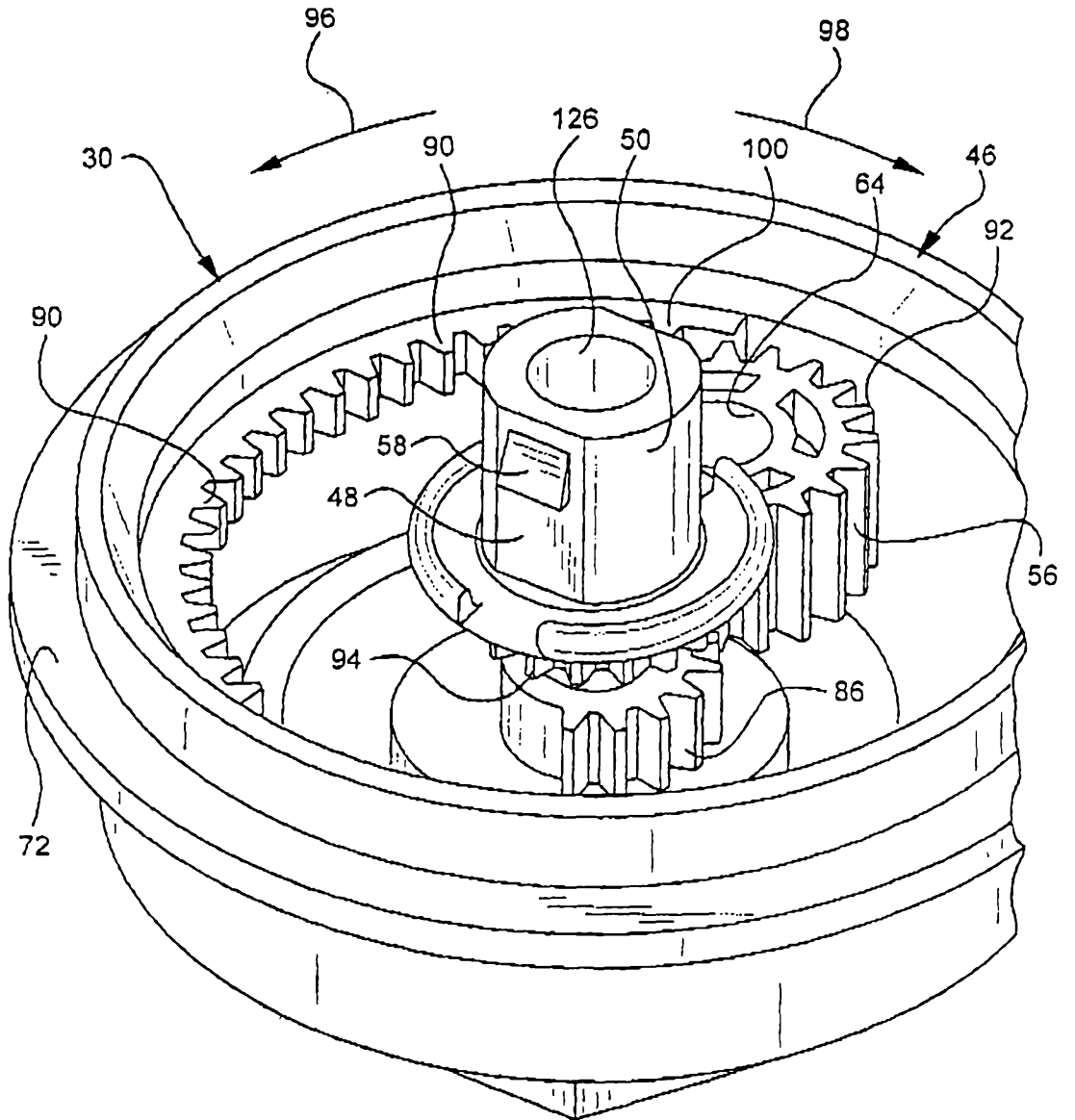
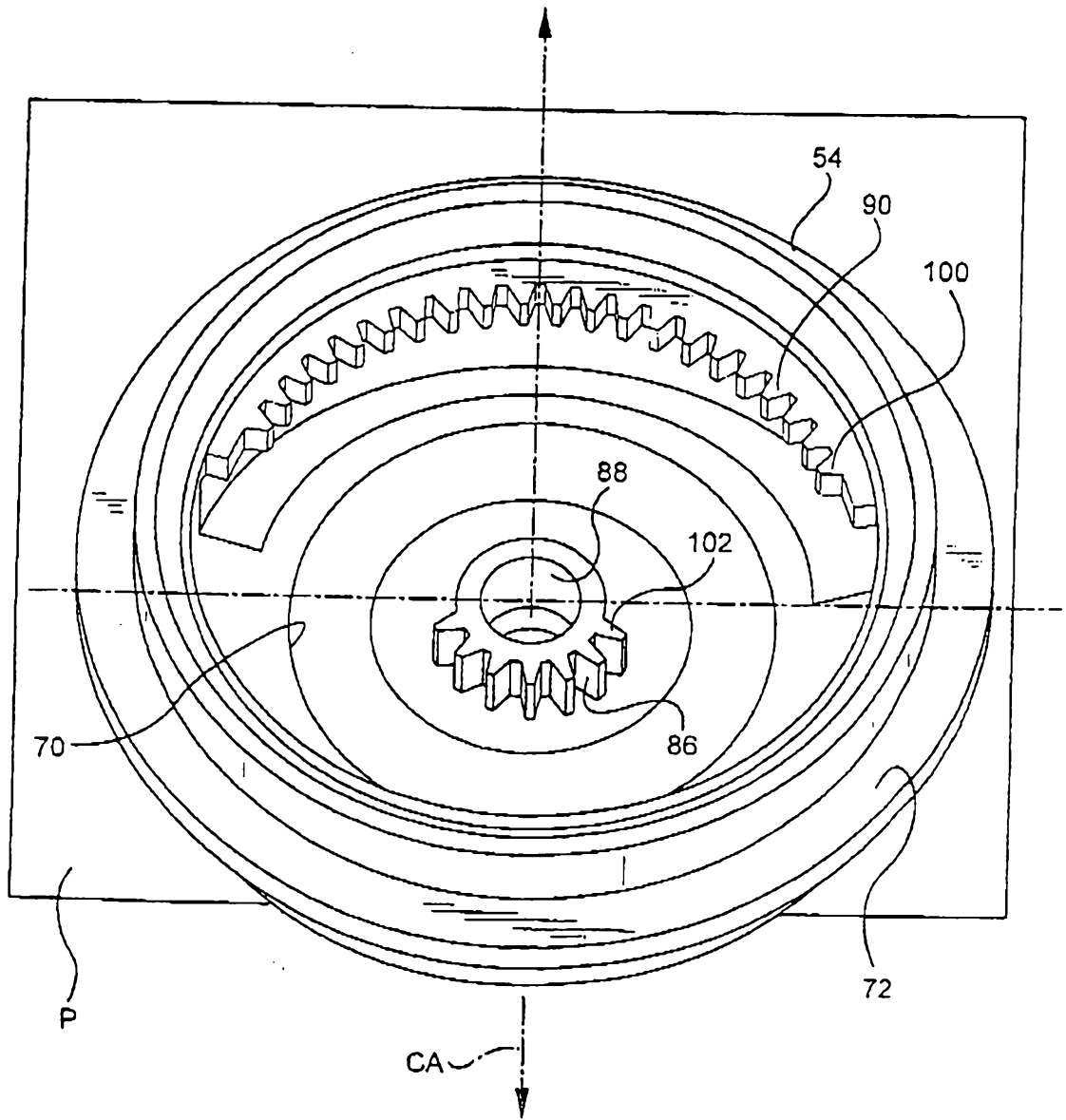

FIG. 17



5
3
E
4
A

FIG. 18

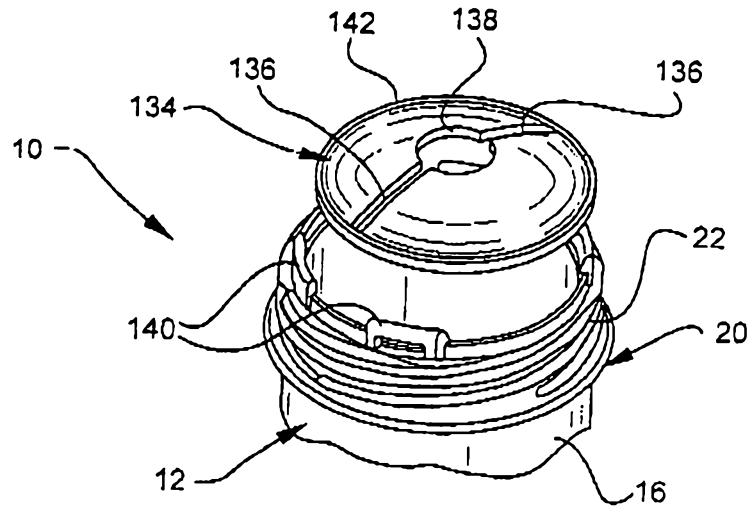

FIG. 19

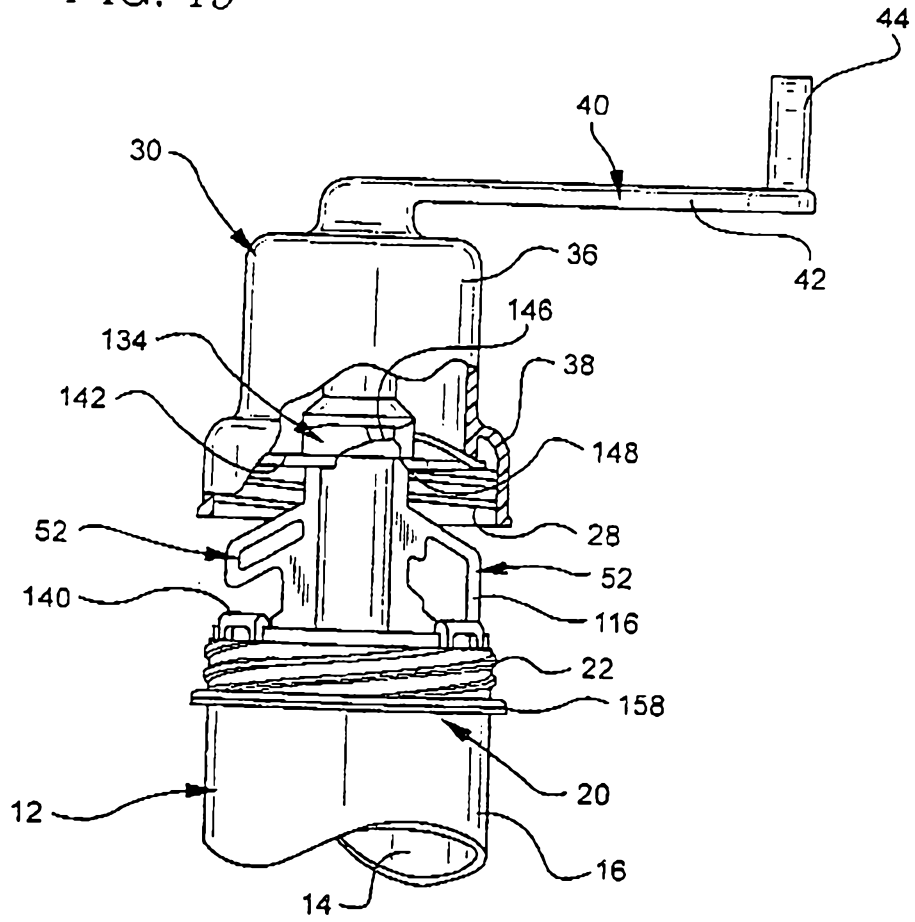

FIG. 20

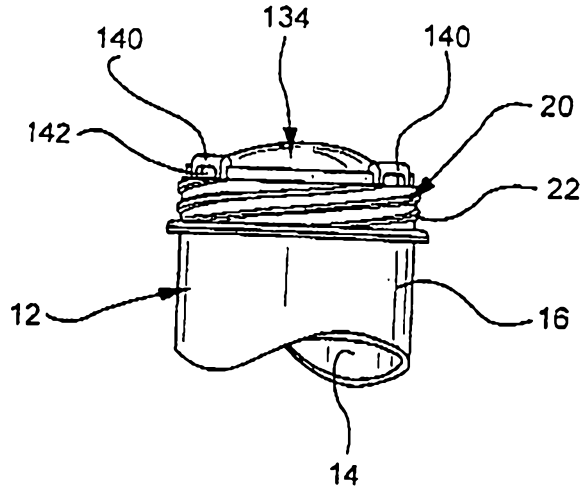

FIG. 21

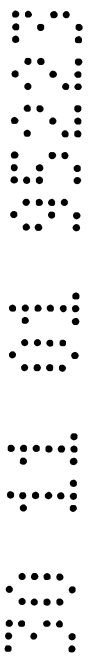
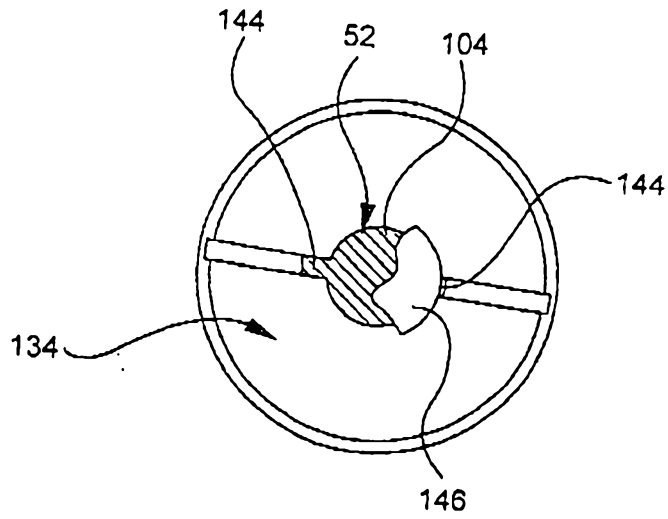

FIG. 22

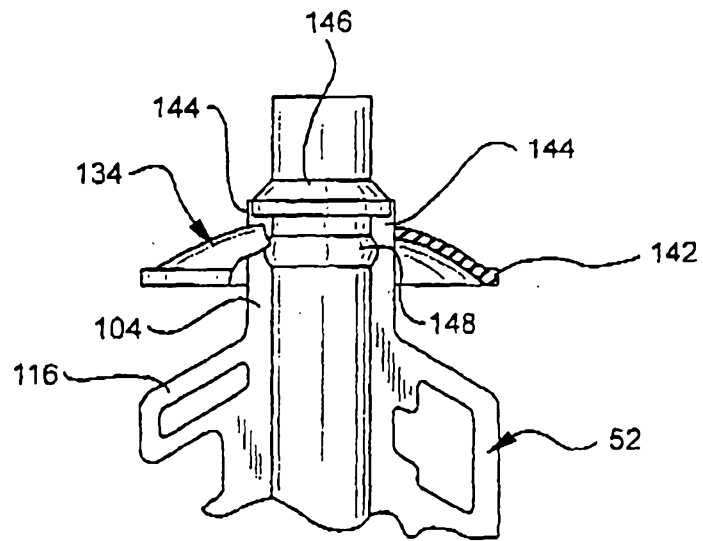

FIG. 23

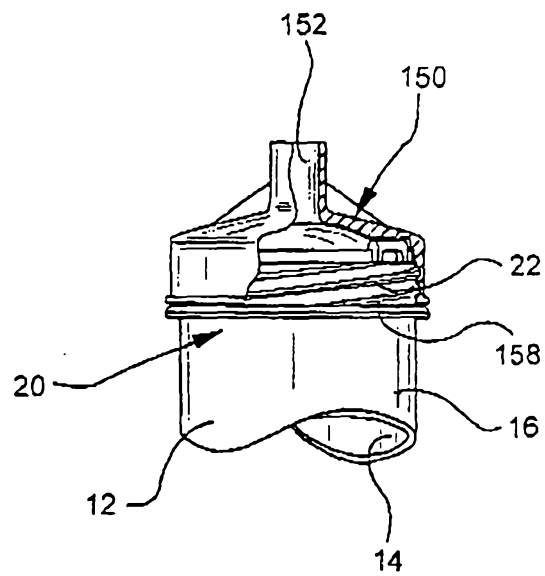

FIG. 24

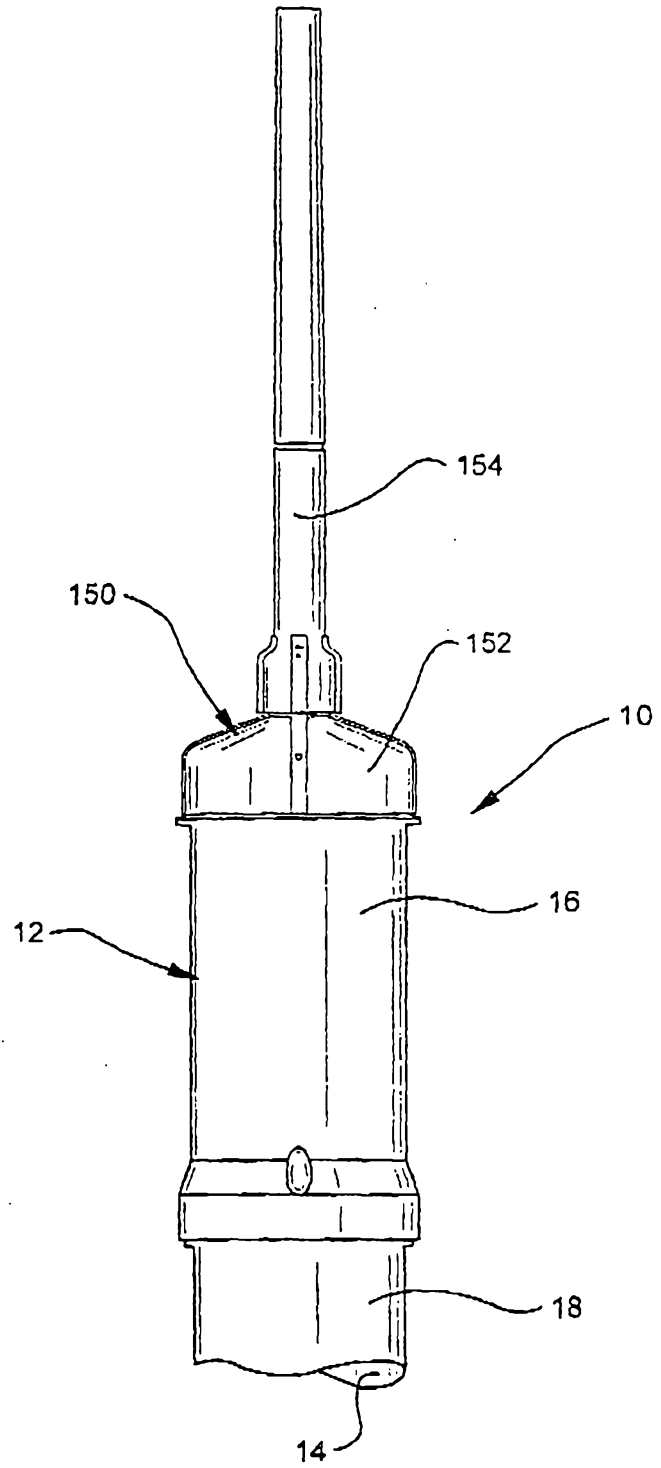

FIG. 25

