

**(12) INNOVATION PATENT**  
**(19) AUSTRALIAN PATENT OFFICE**

(11) Application No. **AU 2014101571 A4**

(54) Title  
**Surface cleaning apparatus**

(51) International Patent Classification(s)  
**A47L 11/34** (2006.01)                      **A47L 13/22** (2006.01)  
**A47L 11/40** (2006.01)

(21) Application No: **2014101571**                      (22) Date of Filing: **2014.02.07**

(30) Priority Data

(31) Number	(32) Date	(33) Country
<b>1311767.6</b>	<b>2013.07.01</b>	<b>GB</b>

(45) Publication Date: **2016.02.25**

(45) Publication Journal Date: **2016.02.25**

(45) Granted Journal Date: **2016.02.25**

(71) Applicant(s)  
**Techtronic Floor Care Technology Limited**

(72) Inventor(s)  
**GROVE, Phil**

(74) Agent / Attorney  
**Griffith Hack, GPO Box 1285, Melbourne, VIC, 3001**

A surface cleaning apparatus including: a cleaning head having a body that defines a footprint to sit adjacent a surface to be cleaned; and a fluid storage container; wherein the cleaning head includes a nozzle configured for directing fluid from the storage container to a surface outside of the footprint of the body.

2014101571 07 Feb 2014

1 / 5

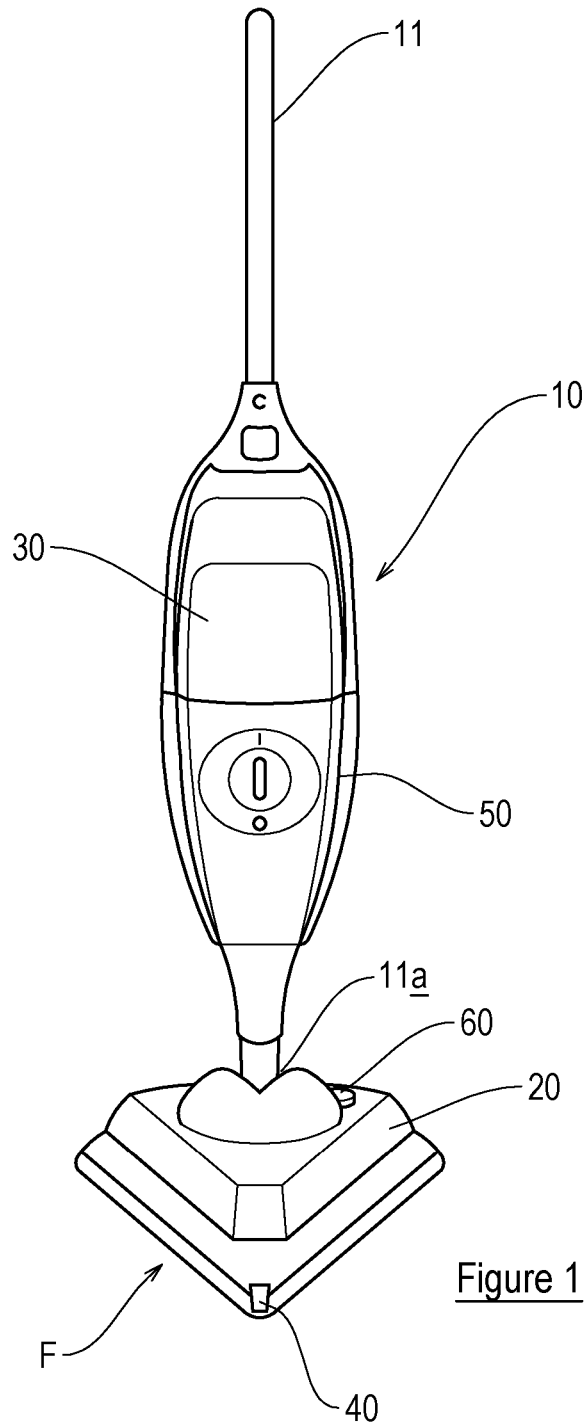

# **EDITORIAL NOTE**

**2014101571**

- There are 6 pages of Description  
the first page is not numbered

Title: Surface cleaning apparatus

5 Description of Invention

This invention relates to a surface cleaning apparatus. More particularly, but not exclusively, this invention relates to an apparatus for cleaning a surface such as a floor or wall which utilises a source of steam. It should be appreciated that the invention is applicable to many other types of surface  
10 cleaning apparatus, for example, carpet washing apparatus / vacuums.

The use of steam cleaners for cleaning floor and other surfaces is well known. For cleaning floor surfaces, a steam cleaner typically has a cleaning head  
15 comprising a body able to be moved, by a user, over the surface to be cleaned, the body being adapted to carry a cleaning element of or including a fabric/textile or other material of a steam permeable absorbent nature. Steam (or very hot water) is emitted from the body and passes through the cleaning element to contact the surface being cleaned, with the effect of loosening dirt  
20 from the surface. Dirty water from condensation of the steam on the surface is absorbed by the cleaning element.

The cleaning head, to enable it to be manipulated over the surface being cleaned, may be attached to a wand and steam supplied thereto by way of a  
25 hose from a separate steam generator. Alternatively, the wand may itself be provided with a steam generator and supply of water, to form a self-contained steam cleaning device, sometimes referred to as a "stick" or "mop" type of steam cleaner.

30 A further provision known in such a steam cleaner is the ability to store a cleaning agent, e.g. a solution of a suitable detergent, to assist the cleaning operation.

According to the present invention, we provide a surface cleaning apparatus including:

5 a cleaning head having a body that defines a footprint to sit adjacent a surface to be cleaned; and

a fluid storage container;

wherein the cleaning head includes a nozzle configured for directing fluid from the storage container to a surface outside of the footprint of the body.

10

Further features of the invention are set out in the claims appended hereto.

Embodiments of the invention will now be described by way of example only with reference to the accompanying figures, of which:

15

FIGURE 1 is a perspective view of a surface cleaning apparatus in accordance with the present invention;

FIGURE 2 is a perspective view of a cleaning head of the apparatus of Figure 1;

20

FIGURE 3 is a plan view of the cleaning head of Figure 2;

FIGURES 4 and 5 are left and right side views of the cleaning head of Figure 2; and

25

FIGURES 6 and 7 are rear and front, respectively, views of the cleaning head of Figure 2.

30

Referring to figure 1 this shows a surface cleaning apparatus 10 in accordance with the present invention. The apparatus 10 has a cleaning head with a body

2014101571 07 Feb 2014

20 which is pivotally connected to a user graspable handle 11. Connected to the user graspable handle 11 is a fluid storage container 30 and a housing 50 which houses a steam generator, a pump for feeding water from the fluid storage container 30 to the steam generator and a fluid passage connecting an output from the steam generator to the cleaning head body 20. The working of the internal components of the apparatus 10 will be described in greater detail later.

10 It can be seen from the figures that a lower end of the handle 11 is pivotally connected to the body 20 by a connection 11a. In order to aid clarity, the handle 11 has been omitted in figures 2 through 7.

15 The cleaning head body 20 is substantially triangular in plan view (see figure 3) and has a rear wall 20a and forwardly facing walls 20b and 20c. The walls 20a, 20b, 20c, define a footprint F which sits adjacent a surface to be cleaned.

20 Advantageously, the apparatus 10 includes a nozzle 40 configured for directing fluid to a surface outside of the footprint F. In the present embodiment the nozzle 40 is connected to a forwardmost portion of the cleaning head body 20 (at the junction of the walls 20b, c) and is shaped so as to direct fluid downwardly towards the surface outside of the footprint F. In the present example the nozzle 40 is fixed relative to the cleaning head body 20, but it should be appreciated that the nozzle 40 could be moveable relative to the body 20. For example, the nozzle could be rotationally moveable so as to direct fluid to either side of a midline which extends through the body 20. Alternatively still, the nozzle could be angularly and/or laterally moveable relative to the body 20. Such movement of the nozzle 40 would permit a user to more accurately direct the nozzle 40 on to a surface being cleaned.

30 Whilst not shown in the figures, the nozzle may include a portion which is telescopically moveable so as to affect displacement between an outlet of the

nozzle 40 and the body 20. In other words, the nozzle 40 could be configured so its overall length could be extended and/or reduced so as to provide the user with a greater control over the distance between an outlet from the nozzle 40 and the surface being cleaned.

5

In some embodiments the nozzle 40 may be made from a resilient material such that it is resiliently moveable relative to the body 20. For example, the nozzle could be made from a rubber or rubber-like material.

10

In some embodiments the nozzle 40 may be detachably connected to the body 20, for example by a screw, press or bayonet connection fitting. Whilst in the present embodiment a single nozzle 40 is provided, embodiments are also envisaged including two or more nozzles 40. In such embodiments the nozzles could be positioned at any location around the periphery of the cleaning head body 20. For example the one nozzle may be positioned somewhere along the wall 20b whilst another is positioned somewhere along the wall 20c. In addition, or as an alternative, the nozzle or one of the nozzles may be positioned on the rear wall 20a.

15

20

The apparatus 10 includes a valve for controlling the flow of fluid from the container 30 to the nozzle 40. That valve is actuated by a user operable switch 60 which is positioned on the body 20 of the cleaning head. The switch 60 is hand or foot operable.

25

In the present invention, as discussed above, the apparatus 10 includes a steam generator in fluid connection with the water storage container 30. The steam generator includes at least one heating element positioned in a suitable housing which heats water pumped thereto from the container 30 by a pump. The purpose of the steam generator is to boil the water so as to generate steam which is then passed through suitable fluid passages to the underside of the cleaning head body 20 and to the nozzle 40. Thus, the footprint F of the

30



body 20 receives a proportion of the steam generated and, when the valve is opened by pressing the switch 60, steam is permitted to pass through a suitable fluid passage to the nozzle 40. In some embodiment the valve may be configured to permit steam to pass to either the footprint F or the nozzle, or to both footprint F and the nozzle 40 at the same time.

In some embodiments the apparatus may include a detergent storage container and a detergent passage for directing detergent from the detergent storage container to the nozzle 40. In such an embodiment the apparatus may include a common passage connecting the outlet from the steam generator to the detergent passage so as to provide a combination of detergent and steam to the nozzle 40. As an alternative, the nozzle may include respective outlets from the steam generator and from the detergent passage (i.e. there being two outlets from the nozzle 40). In some embodiments the apparatus may include a device, e.g. a switch or user controllable dial, for controlling the amount of steam and/or detergent which is passed to the nozzle 40. Such a device may include one or more valves positioned in the steam and detergent passages to control the flow of fluid therethrough.

Although not shown in the figures, the apparatus may include one or more tools for cleaning, with each tool having a conduit, e.g. a flexible pipe or the like, which is connectable to the outlet from the nozzle 40. As an alternative, where the nozzle 40 is detachably connected to the body 20, the conduit for each tool may be connectable to the respective part of the body to which the nozzle 40 connects. Such a connection may be a press connection, a screw threaded connection or a bayonet connection. Other suitable connections are envisaged without departing from the scope of the present invention.

The present invention is advantageous over prior art apparatus, because of its ability to provide fluid, e.g. steam and/or detergent, to a floor surface outside of

the footprint F. This is highly desirable to a user as they can more easily clean stubbornly dirty floor areas. The steam being emitted from the nozzle is preferably at a higher pressure and/or flow rate than that which passes to the footprint F, which means that stubbornly dirty floor areas are more easily and quickly cleaned. For example, the present invention is suited to surfaces such as tiled floors and walls, with the nozzle being particularly useful in cleaning grout joins between adjacent tiles.

Although not shown in the figures, embodiments of the invention may include a source of suction, e.g. a vacuum source, for removing dirt, emulsified dirt and/or condensed water from the surface being cleaned.

When used in this specification and claims, the terms "comprises" and "comprising" and variations thereof mean that the specified features, steps or integers are included. The terms are not to be interpreted to exclude the presence of other features, steps or components.

The features disclosed in the foregoing description, or the following claims, or the accompanying drawings, expressed in their specific forms or in terms of a means for performing the disclosed function, or a method or process for attaining the disclosed result, as appropriate, may, separately, or in any combination of such features, be utilised for realising the invention in diverse forms thereof.

## CLAIMS

1. A surface cleaning apparatus including:  
a cleaning head having a body that defines a footprint to sit adjacent a  
5 surface to be cleaned; and  
a fluid storage container;  
wherein the cleaning head includes a nozzle configured for directing  
fluid from the storage container to a surface outside of the footprint of the  
body.  
10
2. An apparatus according to claim 1 wherein the apparatus includes two  
of more of said nozzles, each configured for directing fluid from the storage  
container to a surface outside of the footprint of the body.
- 15 3. An apparatus according to any preceding claim wherein the nozzle is  
connected to the body.
4. An apparatus according to any preceding claim wherein the nozzle is  
connected to a forwardly facing part of the body.  
20
5. An apparatus according to any preceding claim wherein the nozzle is  
moveable relative to the body.
6. An apparatus according to any preceding claim wherein the nozzle is  
25 rotationally moveable relative to the body.
7. An apparatus according to any preceding claim wherein the nozzle is  
angularly moveable relative to the body.
- 30 8. An apparatus according to any preceding claim wherein the nozzle is  
laterally moveable relative to the body.

9. An apparatus according to any preceding claim wherein the nozzle includes a portion which is telescopically moveable so as to effect a displacement between an outlet of the nozzle and the body.
- 5
10. An apparatus according to any preceding claim wherein the nozzle is moveable towards and away from the surface to be cleaned.
11. An apparatus according to any preceding claim wherein the nozzle is resiliently moveable.
- 10
12. An apparatus according to any preceding claim wherein the nozzle is detachably connected to the body.
13. An apparatus according to claim 12 wherein the detachable connection is provided by one of suitable screw or bayonet connection formations provided on the body and nozzle.
- 15
14. An apparatus according to claim 12 or claim 13 wherein the apparatus includes a plurality of said nozzles, each of which is connectable to the body as selected by a user.
- 20
15. An apparatus according to any preceding claim wherein the apparatus includes a valve for controlling the flow of fluid from the storage container to the nozzle(s).
- 25
16. An apparatus according to claim 15 wherein the valve is actuated by a user operable switch.
17. An apparatus according to claim 16 wherein the switch is configured for controlling the amount of fluid which passes to the nozzle.
- 30

18. An apparatus according to any preceding claim wherein the fluid storage container is a water storage container and wherein the apparatus includes:

- 5 a steam generator including a heating element(s);  
a pump for feeding water from the water storage container to the steam generator; and  
a fluid passage for directing steam from the steam generator to a cleaning head of the apparatus,

10 wherein the apparatus includes a further fluid passage for directing steam from the steam generator to the nozzle.

19. An apparatus according to claim 18, as dependent on claim 16 or claim 17, wherein the switch is configured for controlling the amount of steam which  
15 passes from the steam generator to the nozzle and/or to the cleaning head.

20. An apparatus according to any one of claims 1 to 17 wherein the fluid storage container is configured for holding a fluid containing a detergent.

20 21. An apparatus according to claim 20, as dependent on claim 16 or claim 17, wherein the switch is configured for controlling the amount of detergent which passes from the detergent storage container to the nozzle and/or to the cleaning head.

25 22. An apparatus according to any one of claims 1 to 17 wherein the fluid storage container is a water storage container and wherein the apparatus includes:

- a steam generator in fluid communication with the water storage container, the steam generator including a heating element(s);  
30 a pump for feeding water from the water storage container to the steam generator;

a steam passage for directing steam from the steam generator to a cleaning head of the apparatus;

a further steam passage for directing steam from the steam generator to the nozzle;

5 a detergent storage container; and

a detergent passage for directing detergent from the detergent storage container to the nozzle.

23. An apparatus according to claim 22 wherein the detergent passage and  
10 the further steam passage are connected to a common passage which connects to the nozzle.

24. An apparatus according to claim 22 or claim 23 wherein the nozzle  
15 includes respective outlets from the further steam passage and from the detergent passage.

25. An apparatus according to any one of claims 22 to 24 wherein the  
apparatus includes a device for controlling the amount of steam and/or  
detergent which is directed to the nozzle.

20

26. An apparatus according to claim 25 wherein the device includes one or  
more valves.

27. An apparatus according to claim 26 wherein the valve is controlled by a  
25 user operable switch.

28. An apparatus according to claim 27 wherein user operable switch is  
hand or foot operable and is positioned on the body of the cleaning head.

29. An apparatus according to claim 27 or claim 28 wherein the apparatus includes a wand / handle and wherein the user operable switch is positioned thereon.

5 30. An apparatus according to any preceding claim wherein the apparatus includes one or more tools for cleaning, each tool having a conduit which is connectable to the nozzle.

10 31. An apparatus according to any preceding claim, when dependent on any one of claims 12 to 14, wherein the apparatus includes one or more tools for cleaning, each tool having a conduit which is connectable to a respective part of the body to which the nozzle connects.

15 32. An apparatus according to any preceding claim including a source of suction for removing, for examples dirt, emulsified dirt and/or condensed water, from the surface being cleaned.

20 33. An apparatus substantially as hereinbefore described with reference to and as shown in the accompanying drawings.

34. Any novel feature or novel combination of features described herein and/or in the accompanying drawings.

2014101571 07 Feb 2014

1 / 5

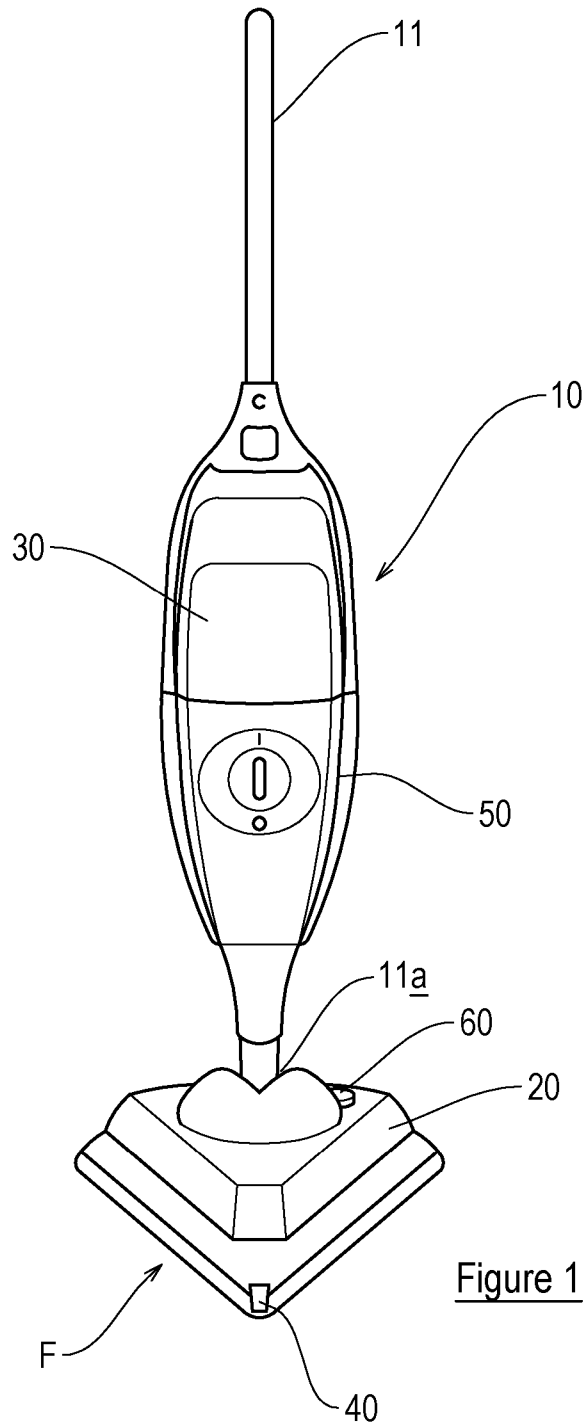



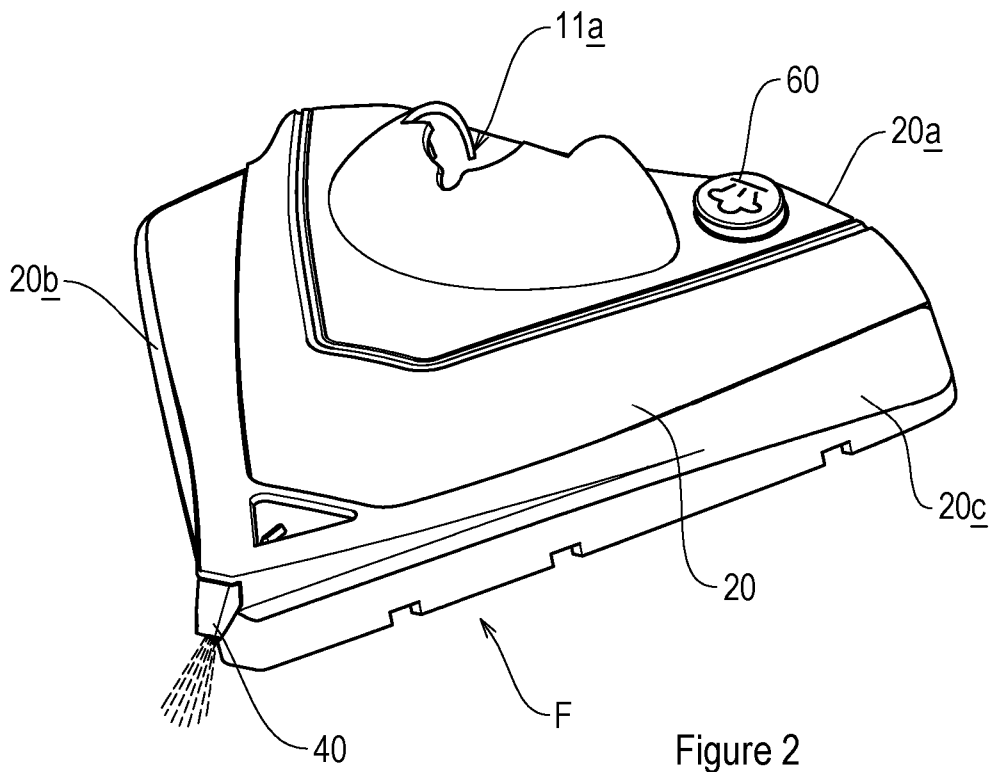

Figure 2

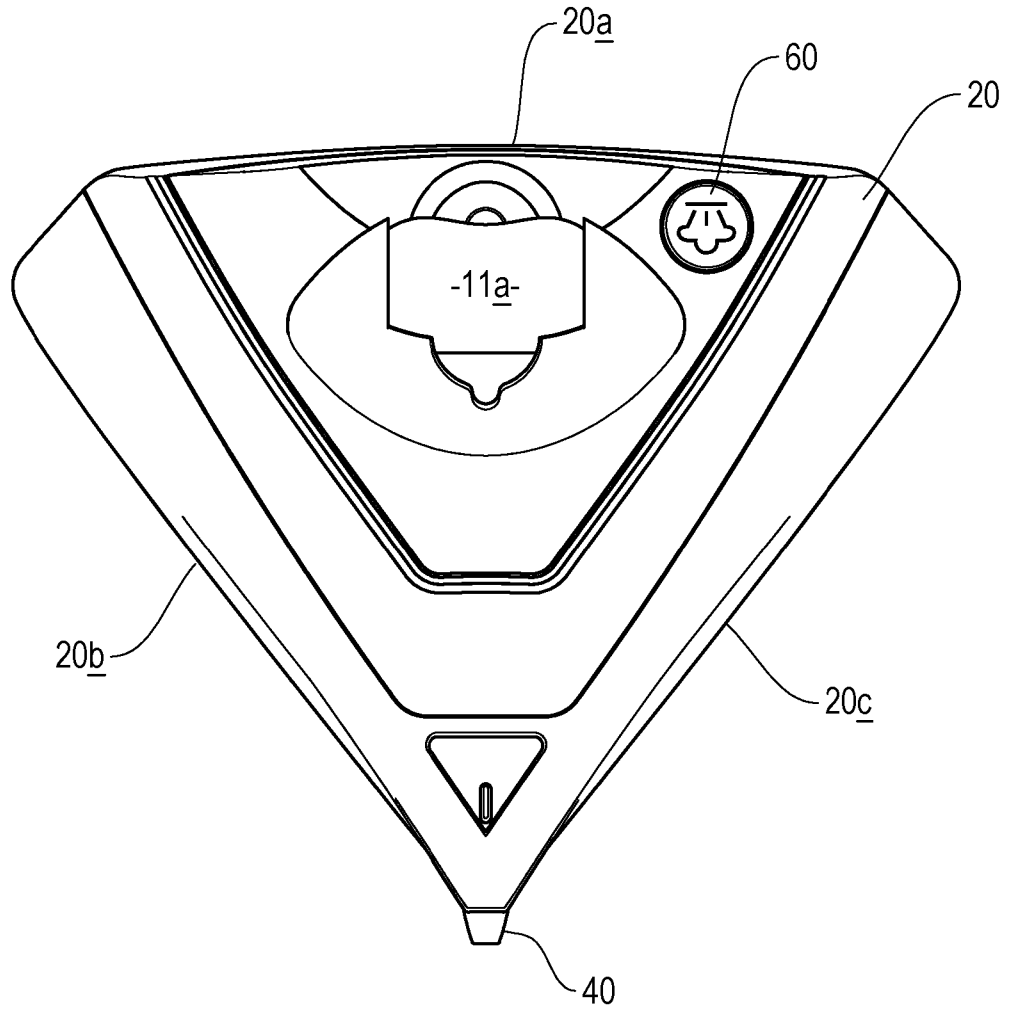

Figure 3

