

July 3, 1951

J. HILLIER

2,559,505

ART OF MAKING DUPLICATE MAGNETIC PHONOGRAPH RECORDS

Filed Feb. 3, 1948

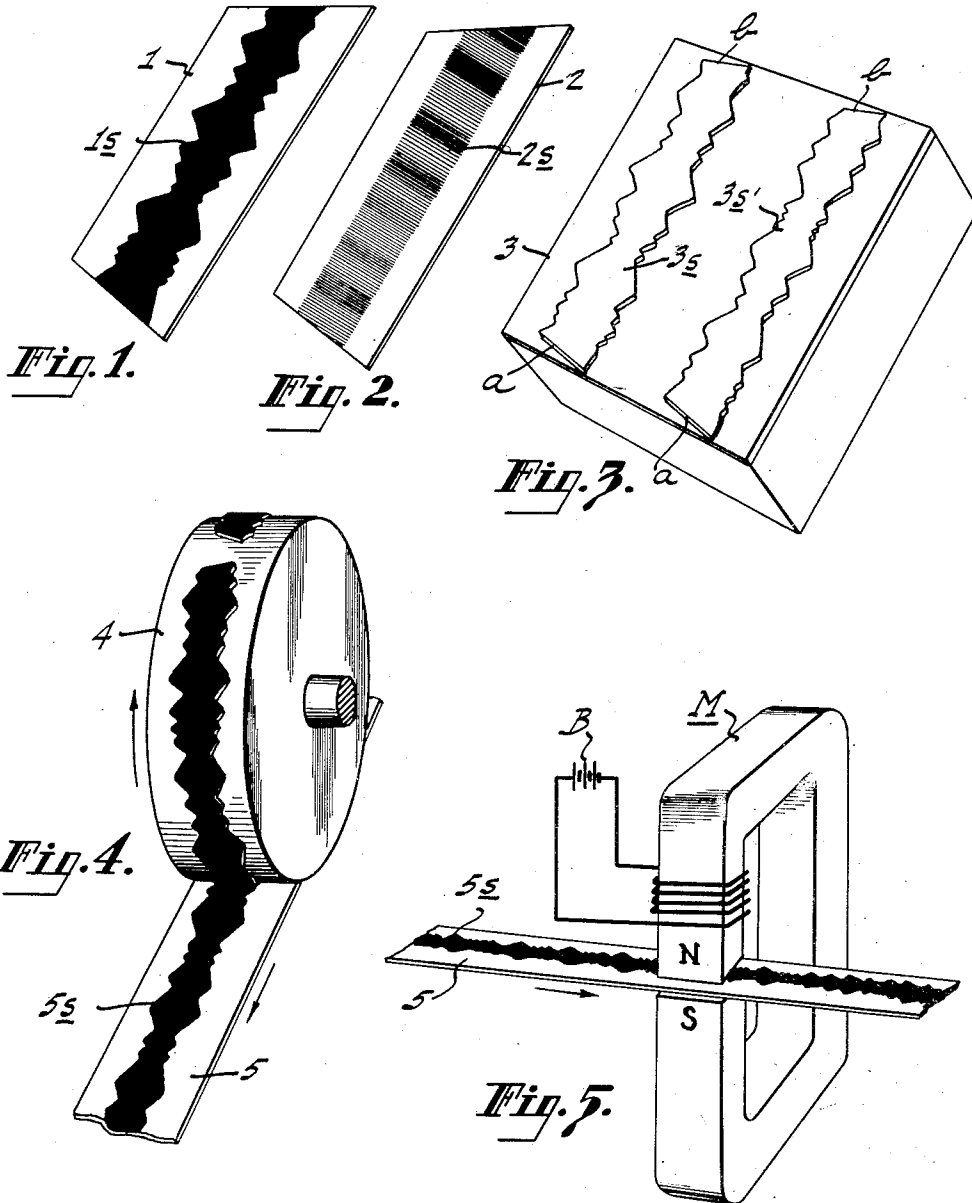

INVENTOR
JAMES HILLIER
BY *Marshall Rabin*
ATTORNEY

UNITED STATES PATENT OFFICE

2,559,505

ART OF MAKING DUPLICATE MAGNETIC PHONOGRAPH RECORDS

James Hillier, Cranbury, N. J., assignor to Radio Corporation of America, a corporation of Delaware

Application February 3, 1948, Serial No. 5,989

1 Claim. (Cl. 179—100.2)

1

My present invention relates to the manufacture, especially by mass production methods, of magnetic phonograph records of the tape and disc types.

Although modern magnetic phonograph records possess certain obvious advantages over conventional "shellac-disc" records, the former have not achieved the commercial acceptance which they apparently merit. This is so, at least in part, because of the difficulties incident to the manufacture of high quality, low cost magnetic records by presently known mass production methods. Thus, it may be said, generally, that the duplication of magnetic records by "re-recording" is expensive not only because of the cost of installing and servicing large banks of recording heads, but because the time cycle involved in the production of the duplicate records can never be less than the playing time of the record being duplicated. Another prior art record-duplicating method (see British Patent 371,329) involves the production, by photographic methods, of a record having a sound track constituted of a light sensitive emulsion which is capable of presenting varying dielectric or varying permeability properties corresponding to the recorded sound. But such records, being unmagnetized, are not truly "magnetic-records" and are not ordinarily capable of being used in conjunction with phonographs employing pick-ups and amplifiers of ordinary sensitivity.

Accordingly, the principal object of the present invention is to provide an economical and rapid method of providing duplicate magnetic records of standard form, dimensions and magnetic properties.

The manner in which I achieve the foregoing and other objects are described in connection with the accompanying drawing, wherein:

Figs. 1 and 2 are views in perspective showing pieces of photographic film containing variable-width (Fig. 1) and variable density (Fig. 2) sound-tracks and which will be referred to in describing the first step of the method of my invention,

Fig. 3 is a view in perspective of a printing matrix comprising a replica of the sound track of Fig. 1,

Fig. 4 is a view in perspective of a printing machine, employing a matrix similar to the one shown in Fig. 3, in the act of printing upon a paper or similar record-blank and

Fig. 5 is a view in perspective showing the printed record blank of Fig. 3 being passed between the poles of an electromagnet for the pur-

2

pose of magnetizing the printed track on the blank.

In carrying my invention into effect I first record the musical composition, or other sounds, photographically, either by the variable-density or variable-width methods.

The master-record, thus recorded, may contain either a spiral sound track (upon a photographic plate) or a straight track (upon an elongated ribbon-like film) as determined by the ultimate form of magnetic-record desired. I have shown, in Fig. 1, a piece of a photographic plate or film 1 containing a variable-width sound-track 1S and, in Fig. 2 a sound track 2S of the variable-density type. In these figures the photographic sound-tracks 1S and 2S are shown with their median lines parallel to the edge of the film or plate (1, 2) though, as above indicated, they may comprise spiral tracks, if desired.

The next step in my method comprises making a negative replica of the sound track in the form of a printing matrix 3, Fig. 3. This I prefer to do by a photoengraving (or other "half-tone") process, though when the sound-track is of the variable-width type (as shown in Figs. 1 and 3) I do not necessarily employ a half-tone process but may use a lithographic or similar process instead. When the original, photographically produced record comprises a long ribbon I may cut the ribbon into a number of short lengths 3S, 3S' so that replicas of several of them may be accommodated upon a single printing matrix, as shown in Fig. 3. In this latter case it will be observed that the ends *a* and *b* of each section of the tracks 3S and 3S' form an angle other than a right angle with respect to the median line thereof. Thus when the strips which are subsequently printed from the matrix are spliced together and magnetized (to form a complete magnetic-sound record) the splices in the complete record will pass gradually, instead of abruptly, across the gap in the "pick-up" of the phonograph and will minimize the "noise" occasioned by the presence of the splice in the record.

I use the printing matrix or an electrotype thereof, (4, Fig. 4) and ink containing finely comminuted magnetizable particles, such for example as magnetic oxide of iron (Fe_3O_4) for printing upon paper, cellophane or analogous (non-magnetic) record blanks 5, a printed replica 5S of the original (photographic) sound track. In the case of the variable-density recording, where the so-called "half-tone" printing process is employed, the magnetizable pigment is deposited upon the paper or other non-magnetic blank as

3

determined by the light and shade of the recording, whereas in the case of a variable-width recording it will be apparent that the pigment will be deposited in a layer of uniform density. In either event, at the time the magnetizable particles are deposited upon the blank they are preferably unmagnetized and, in this condition, do not make up a sound-track capable of being played satisfactorily in a conventional magnetic-phonograph.

The final step in my method involves the magnetization of the heretofore unmagnetized printed sound track 5S by subjecting the magnetizable ink on the printed ribbons (or discs) to a magnetic field of substantially uniform and constant intensity. This I prefer to do simply by passing the otherwise finished duplicate records between the pole pieces N and S of an electromagnet M whose coils are connected to a source of direct current, exemplified by the battery B.

From the foregoing description, it will be apparent that my invention provides a rapid and economical method of making duplicate magnetic records of standard form, dimensions and magnetic properties.

I claim as my invention:

The method of making a magnetic record of sounds which comprises, making a variable-den-

4

sity photographic recording of said sounds, making a half-tone engraving of said variable density photographic recording, printing from said half-tone engraving upon a record blank with the use of ink containing a pigment comprised of permanently magnetizable particles a replica of said variable density photographic recording, and thereafter permanently magnetizing said printed magnetizable replica.

JAMES HILLIER.

REFERENCES CITED

The following references are of record in the file of this patent:

UNITED STATES PATENTS

Number	Name	Date
934,600	Fuller	Sept. 21, 1909
1,152,562	Sherman	Sept. 7, 1915
1,799,322	Robbins	Apr. 7, 1931
1,941,036	Lenk	Dec. 26, 1933
2,109,627	Finch	Mar. 1, 1938

FOREIGN PATENTS

Number	Country	Date
324,994	Great Britain	Feb. 10, 1930
371,329	Great Britain	Oct. 17, 1930