

(19)
(12)

(KR)
(A)

(51) 。 Int. Cl. ⁷
H05B 33/10

(11)
(43)

2002 - 0059535
2002 07 13

(21) 10 - 2001 - 0000972
(22) 2001 01 08

(71)

575

(72)

APT213 - 1306

가23006

4 60 - 4 302 308

2 217 - 1301

2 88 - 11

(74)

:

(54)

(rough)

가 가

가

7

, ,

1

2

3

, ,

4 3

, ,

5

, ,

6, 7

, ,

,

(rough)

가

가 가

,
2

2
가

3

가 가

1

1, 2, 3

1

가

1

가

1

1

(Indium Tin Oxide)

(100)

(200)

(100)

(200)

2

(250)"

(200)

(250)

(310,320,330) 3, 4 (320), (330)
(310), (410) (400)

4 (250) (310,320,330) 가
(100) 5 (500) (600) (500)

(500) (600) 5 (250)
(dot)

(100) (600) (600) (500) 6 7 (310,320,
500) 330)

(500) (550)

(310,320,330)

(ashing)

(550)

(550) 가 (550) 가

(57)

1.

;

1

;

1

1, 2, 3

;

2.

1 , 1 , 3 , 2

3.

(full - color)

;

,

;

;

가

4.

3 , ,

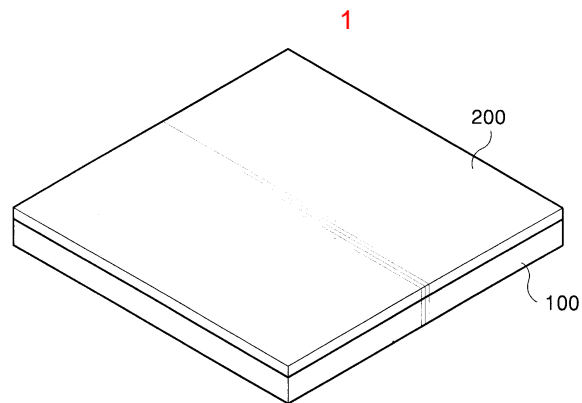

2

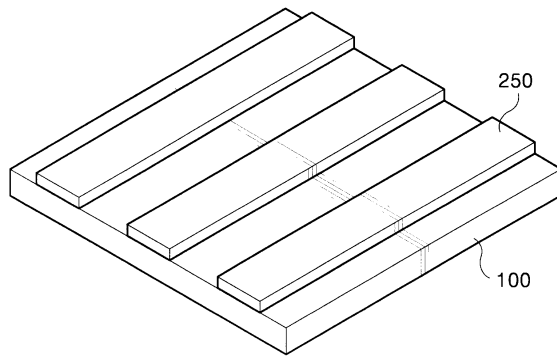

3

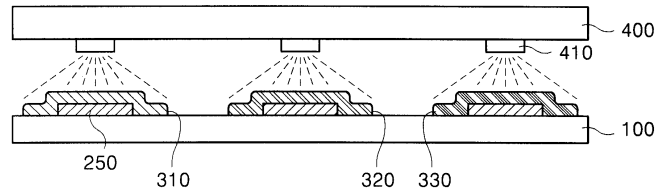

4

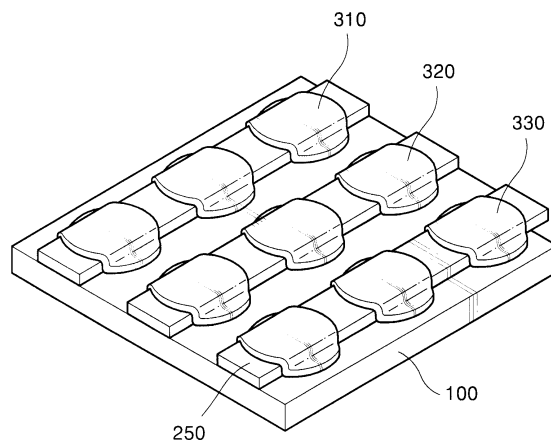

5

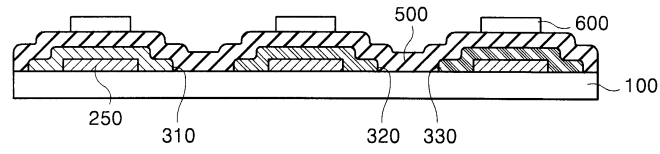

6

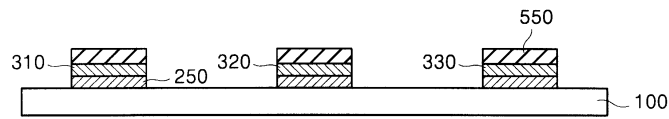

7

