



(19) **United States**

(12) **Patent Application Publication**

Rakib et al.

(10) **Pub. No.: US 2004/0172658 A1**

(43) **Pub. Date:**

Sep. 2, 2004

(54) **HOME NETWORK FOR ORDERING AND DELIVERY OF VIDEO ON DEMAND, TELEPHONE AND OTHER DIGITAL SERVICES**

Publication Classification

(51) **Int. Cl.7** **H04N 7/18; H04N 7/173**

(52) **U.S. Cl.** **725/120; 725/119; 725/78; 725/82; 725/111**

(76) **Inventors:** **Selim Shlomo Rakib**, Cupertino, CA (US); **Ronald Craig Fish**, Morgan Hill, CA (US)

(57) **ABSTRACT**

A gateway for coupling a local area network coupled to a plurality of peripheral devices at a customer premises to one or more external networks that deliver analog signals bearing analog video such as regularly scheduled CATV, terrestrial or satellite C-band broadcasts, or modulated with digital video-on-demand data, or IP packets bearing IP telephony data or data from the internet. The preferred construction is modular so that single expansion modules to interface only to DSL lines or only to a satellite dish or only to HFC, or some combination thereof may be added as needed. The gateway may be a standalone circuit also with hardwired interfaces to one or more external network types. The incoming analog signals are either digitized, compressed and distributed on the local area network or the digital data thereon is recovered and packetized as an IP packet if not already so packetized and distributed via a router process to the device that requested the data via the local area network.

Correspondence Address:

Ronald Craig Fish
Ronald Craig Fish, A Law Corporation
P.O. Box 2258
Morgan Hill, CA 95038 (US)

(21) **Appl. No.:** **10/731,310**

(22) **Filed:** **Dec. 8, 2003**

Related U.S. Application Data

(63) Continuation of application No. 09/483,681, filed on Jan. 14, 2000, now abandoned.

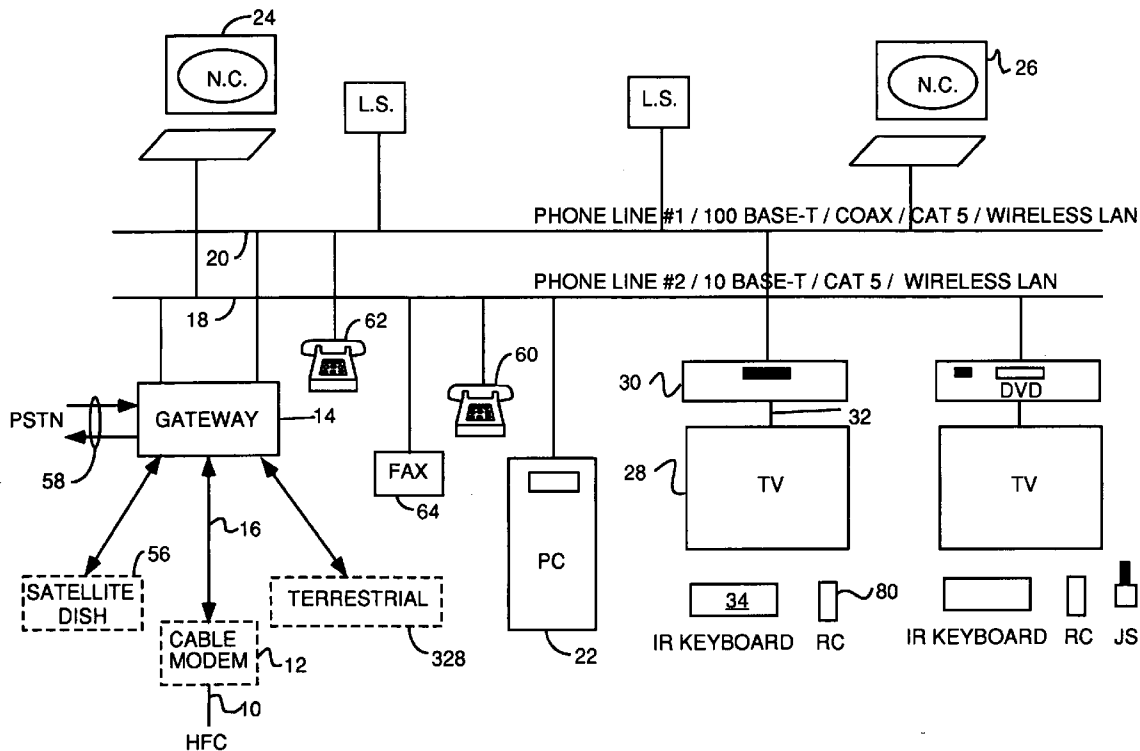

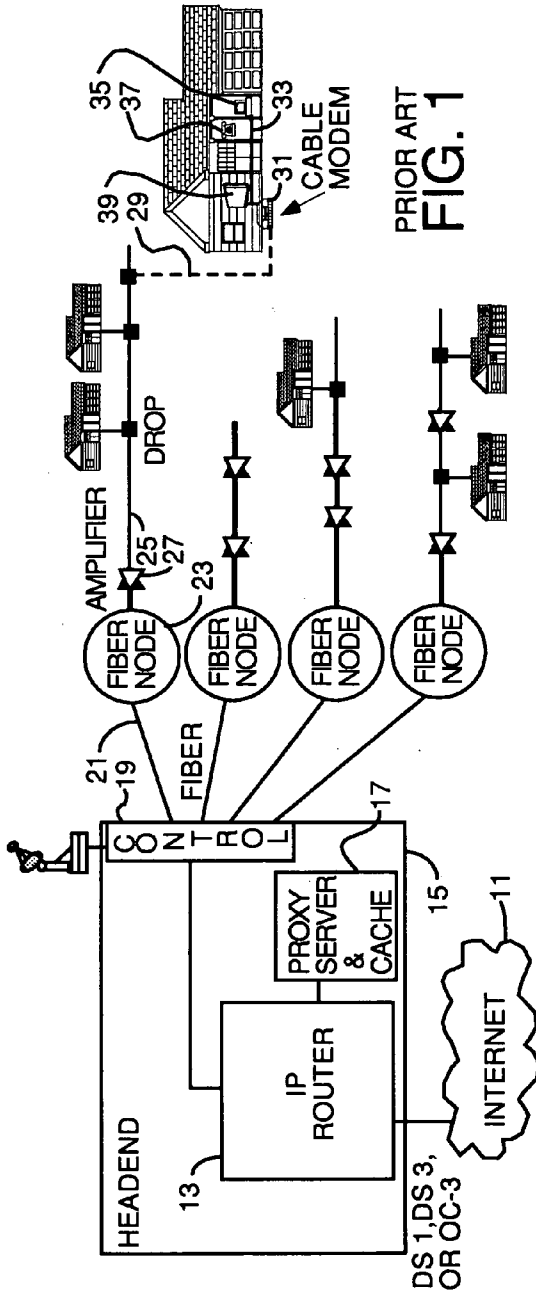

PRIOR ART
FIG. 1

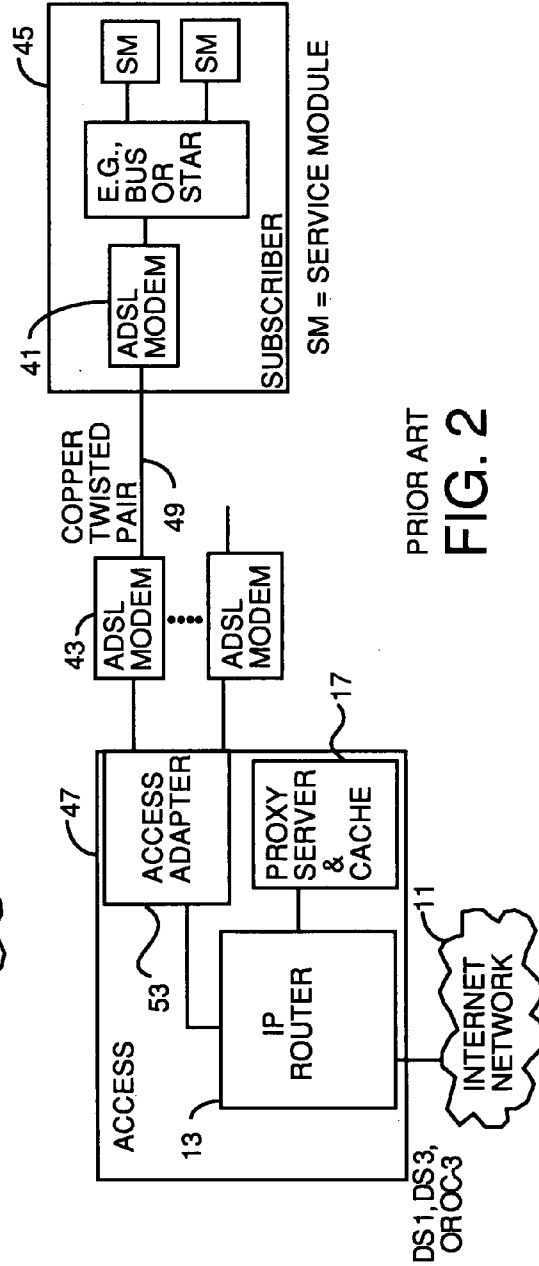

PRIOR ART
FIG. 2

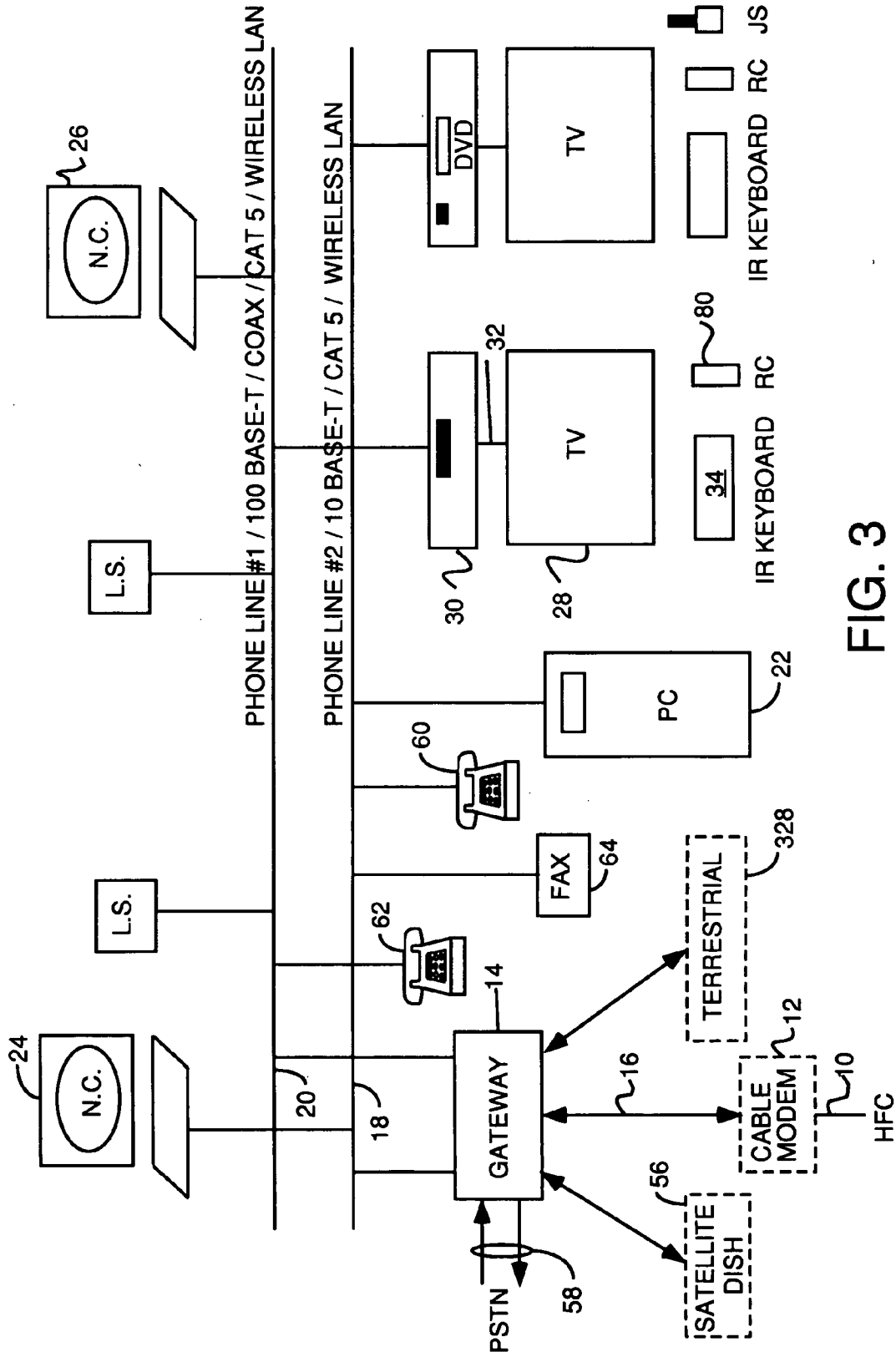

FIG. 3

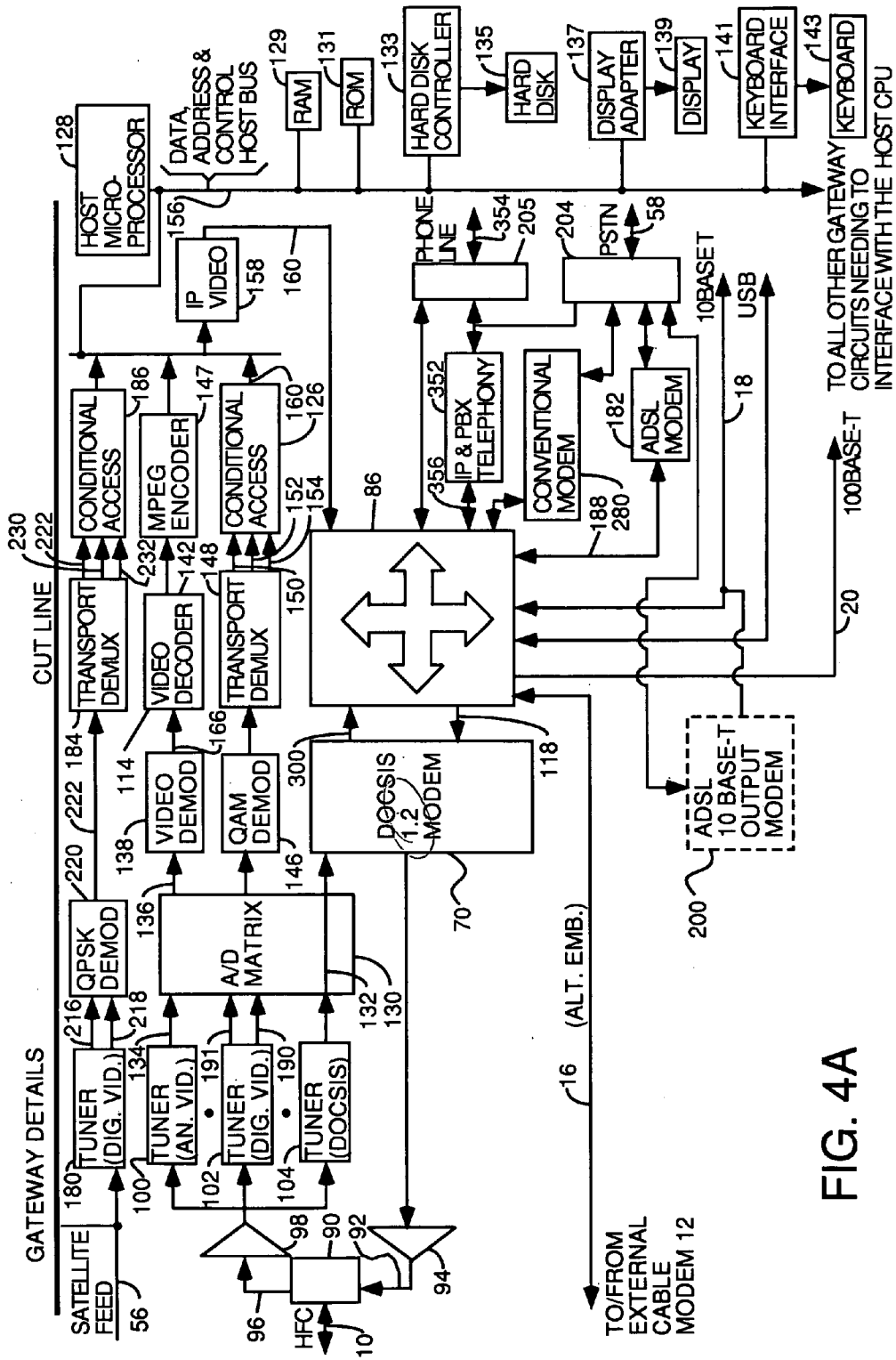

FIG. 4A

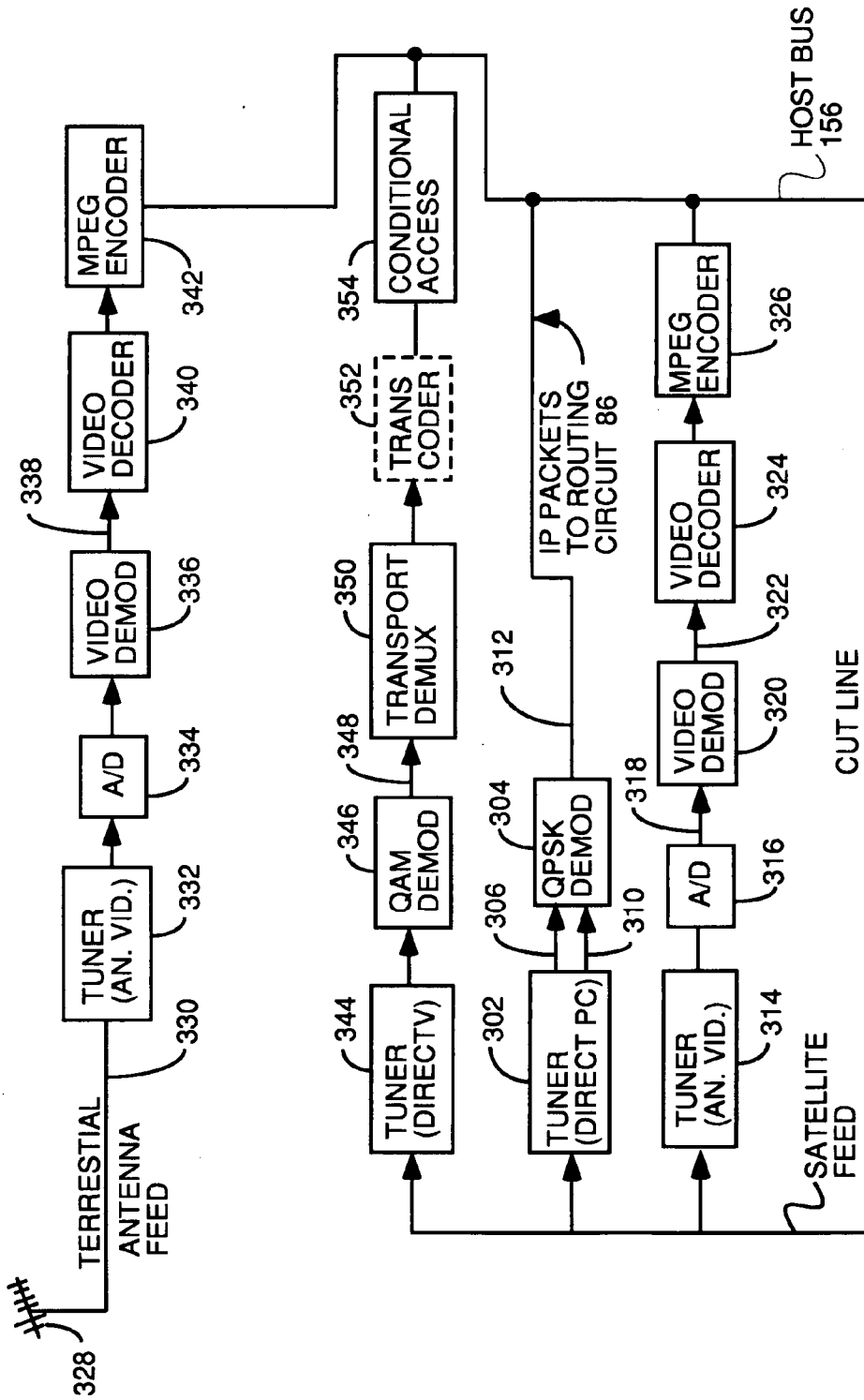

FIG. 4B

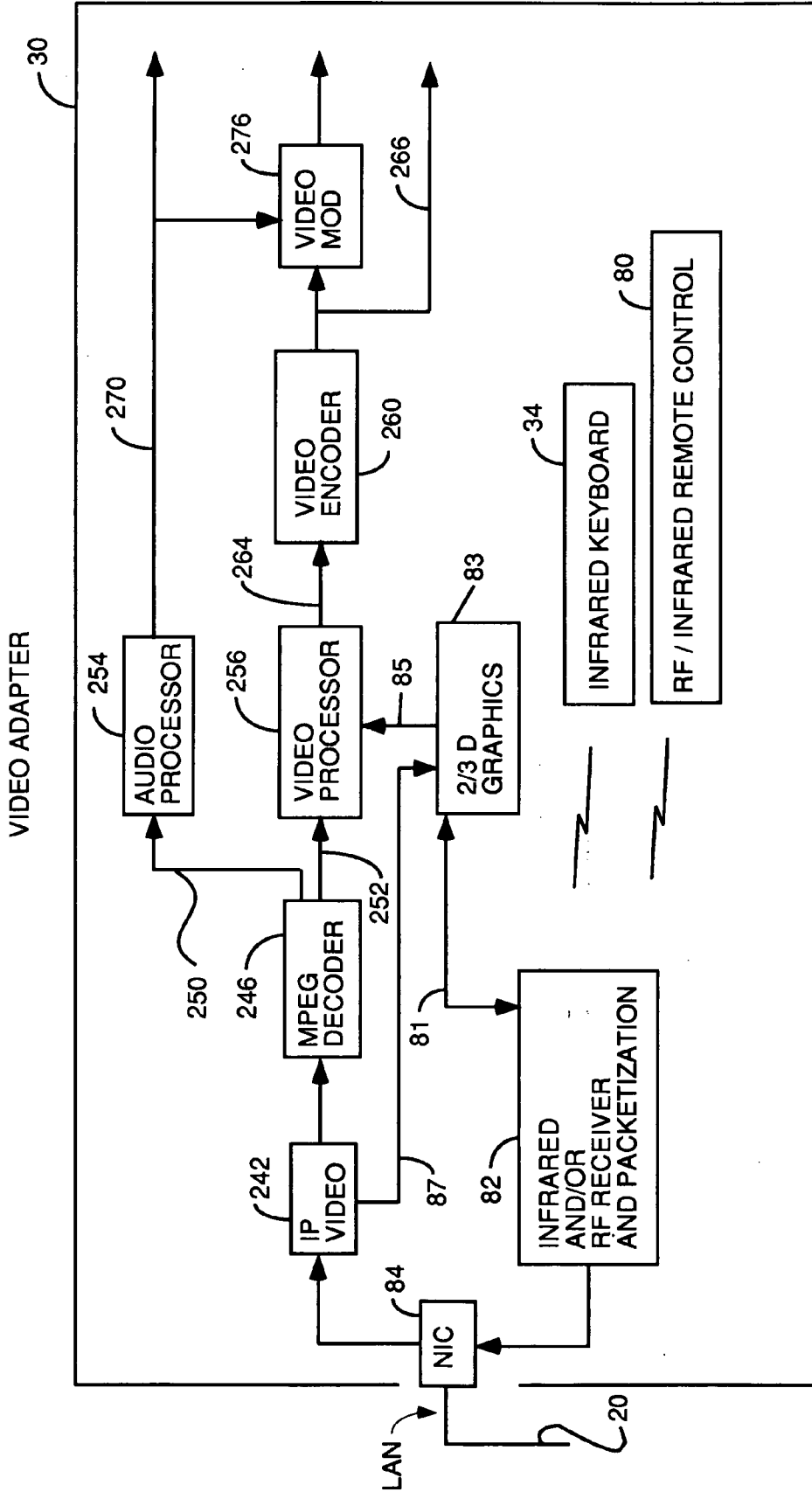

FIG. 5

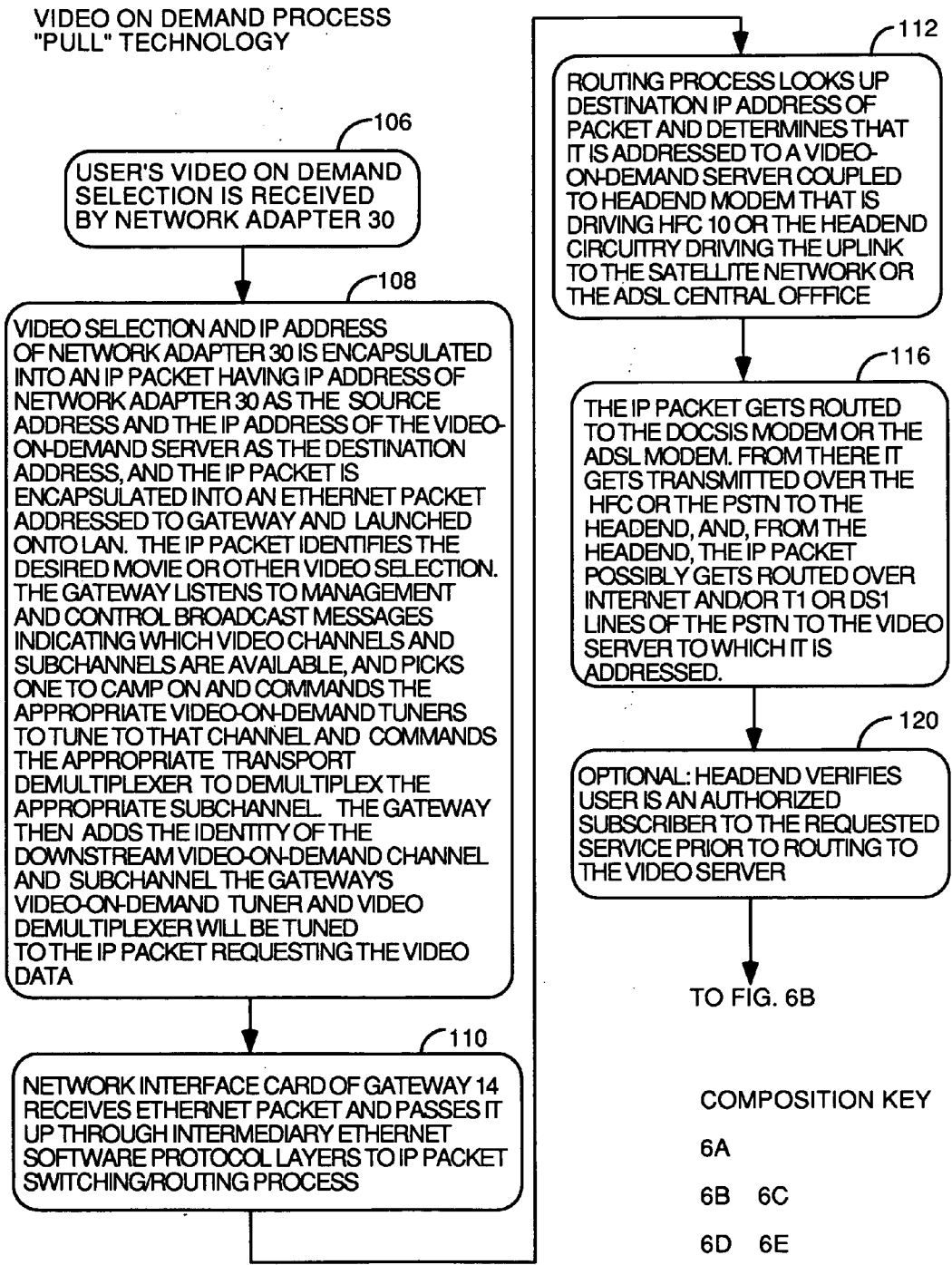

FIG. 6A

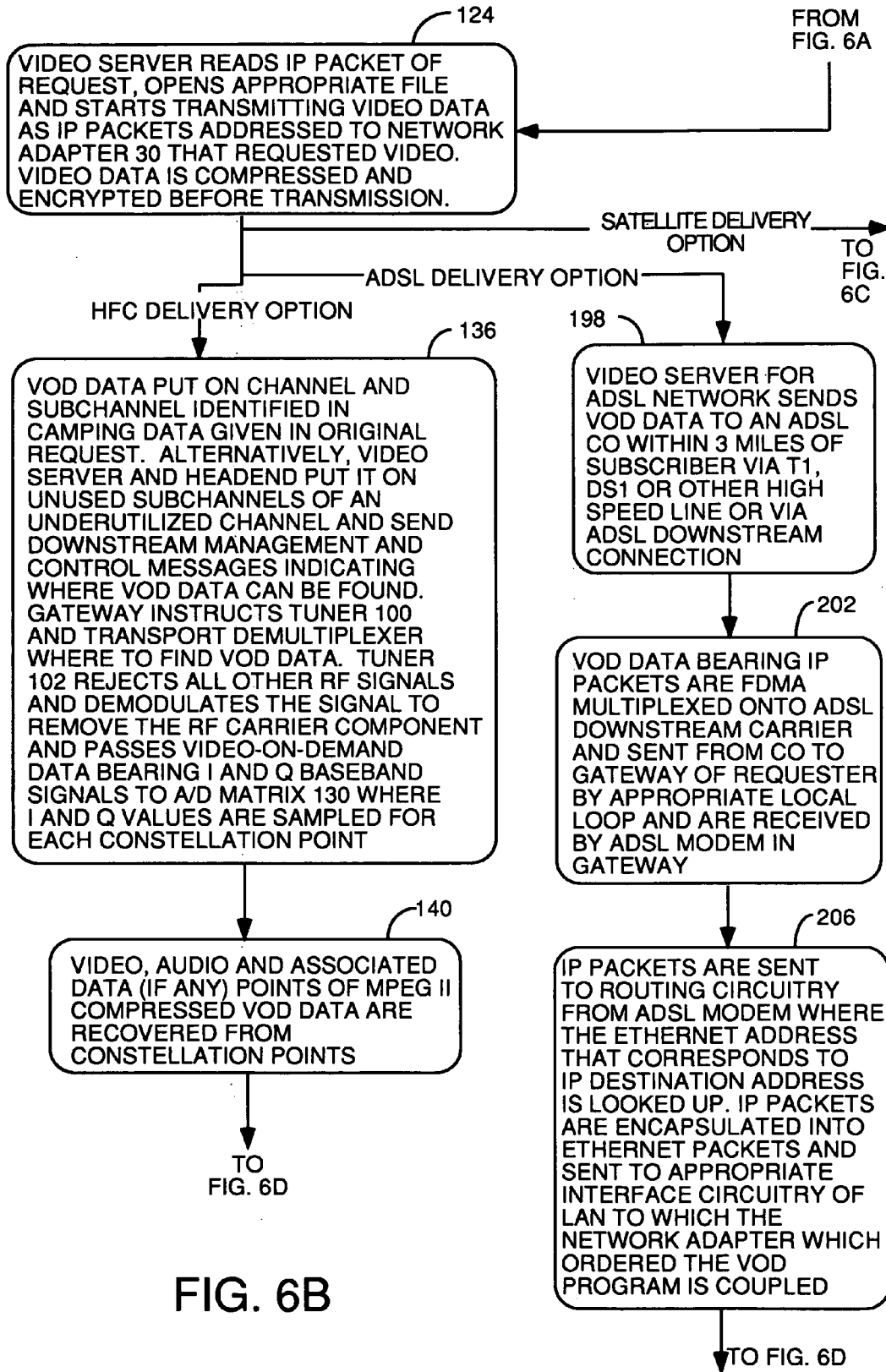

FIG. 6B

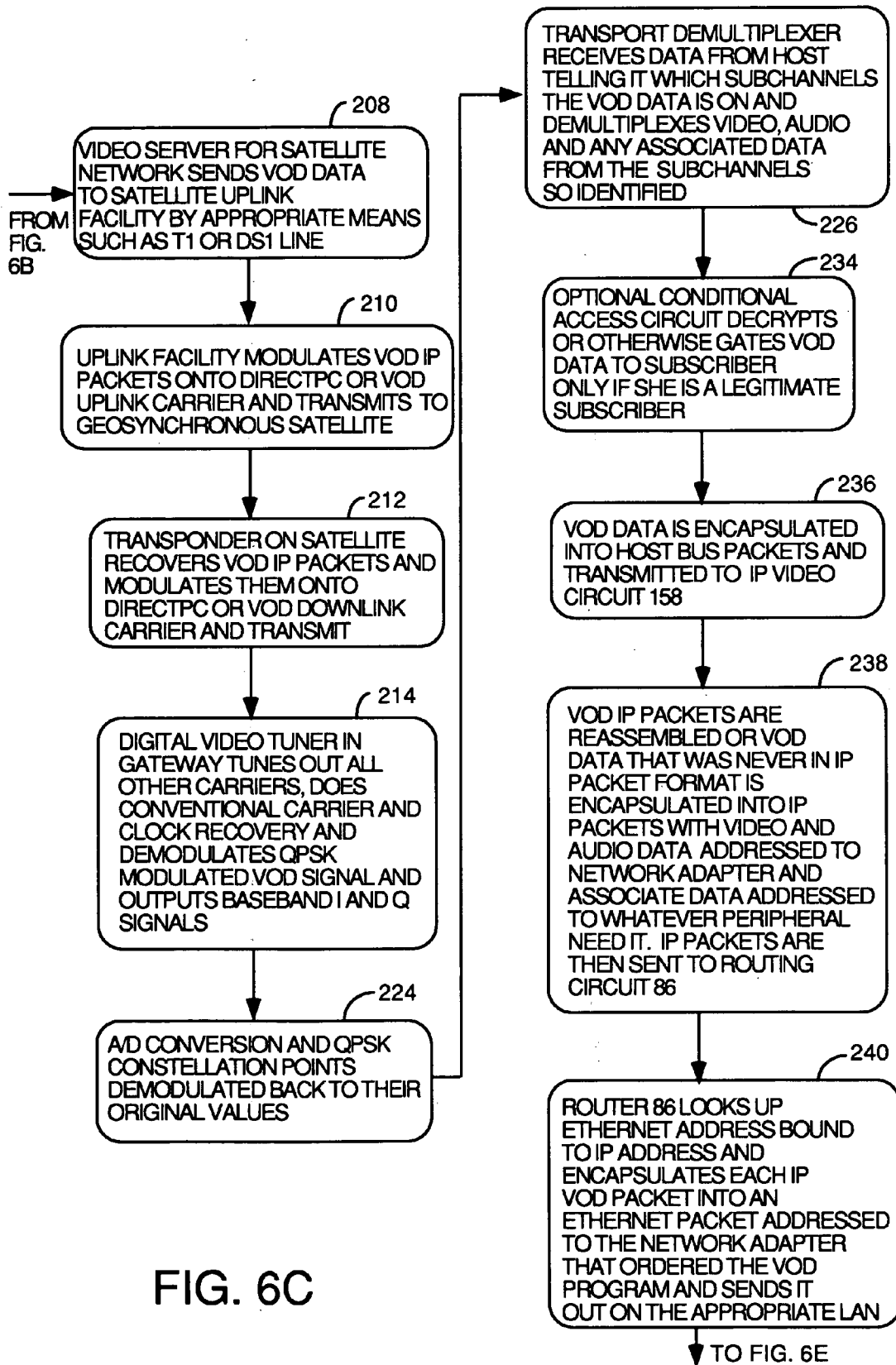

FIG. 6C

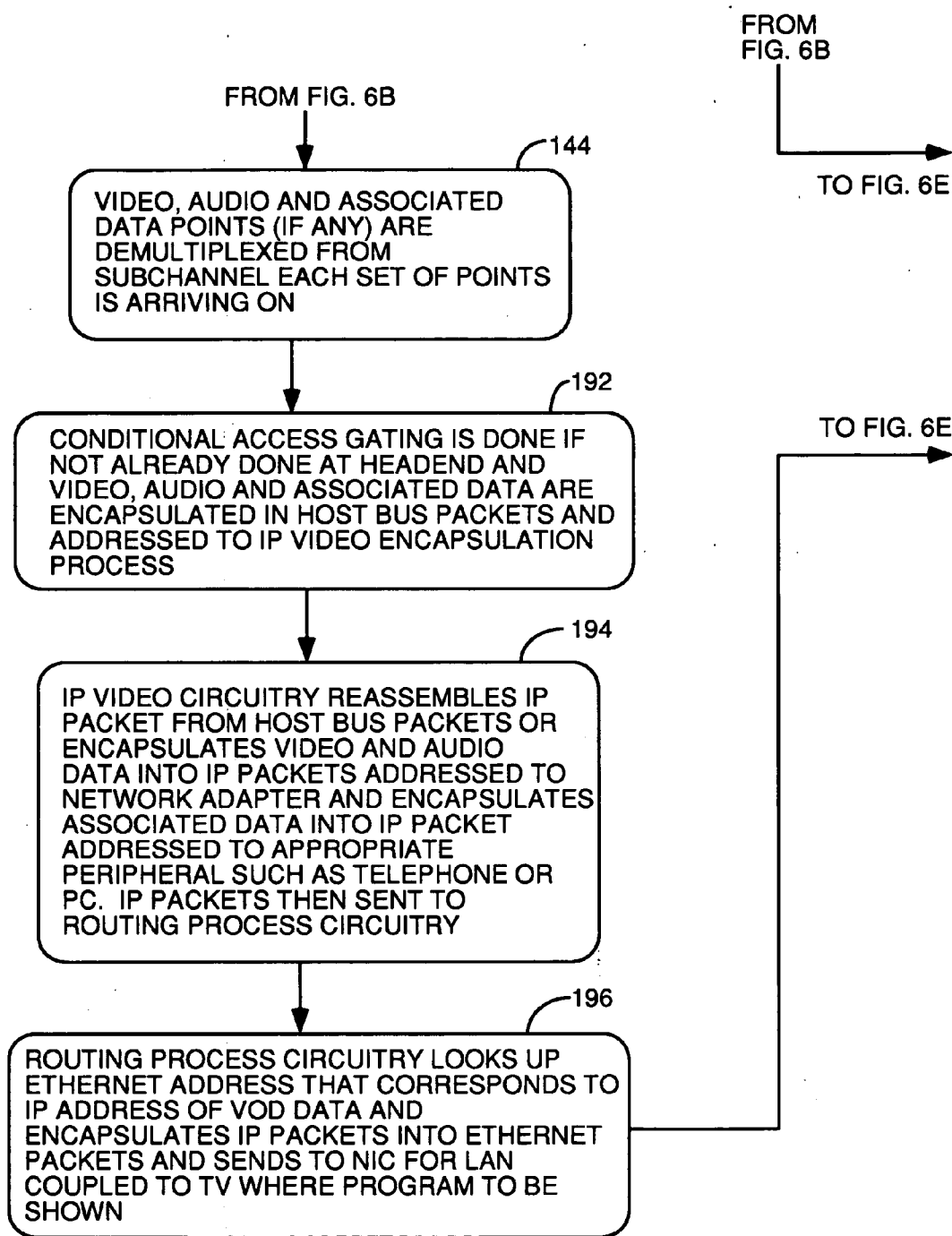

FIG. 6D

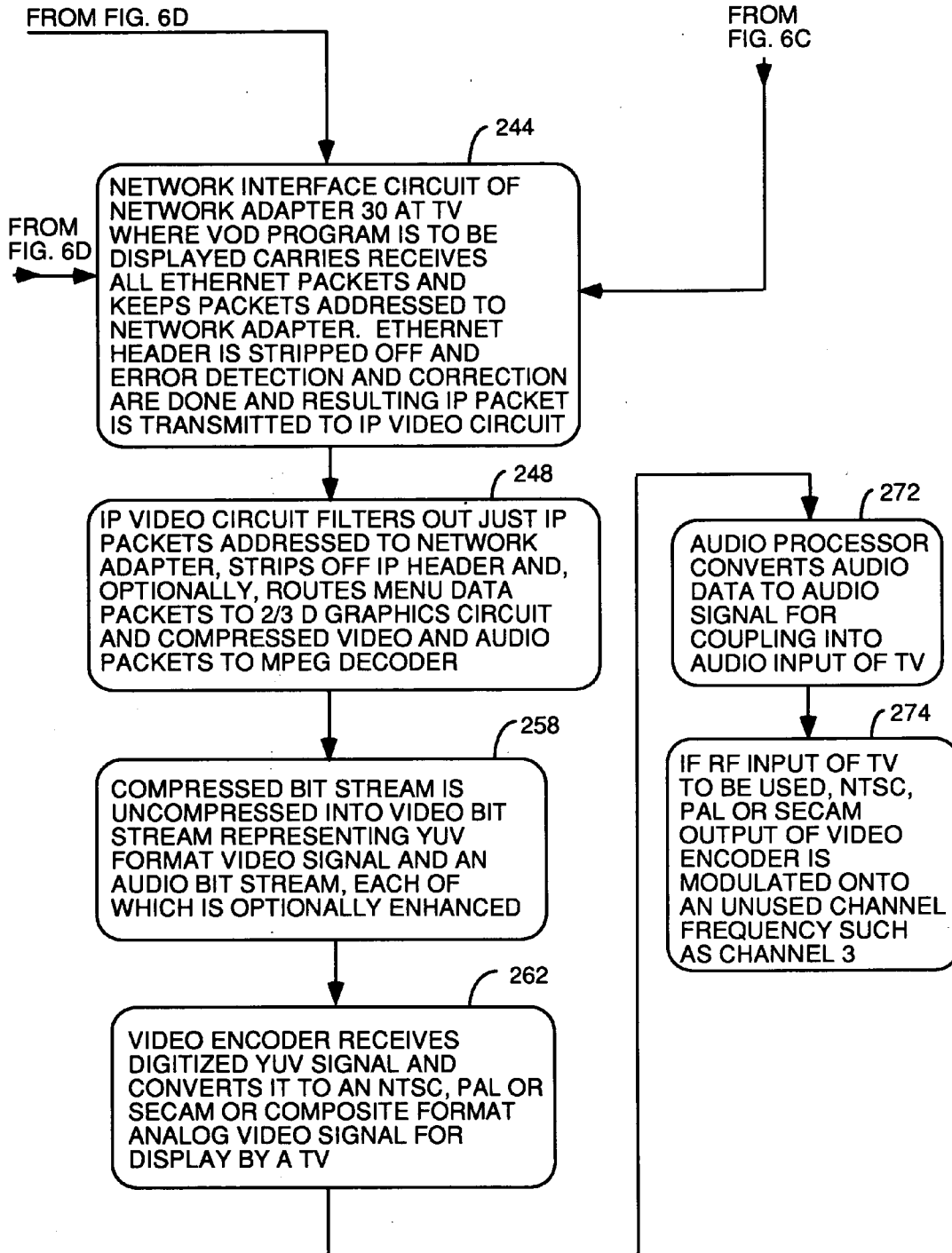

FIG. 6E

WIDEBAND INTERNET ACCESS PROCESS

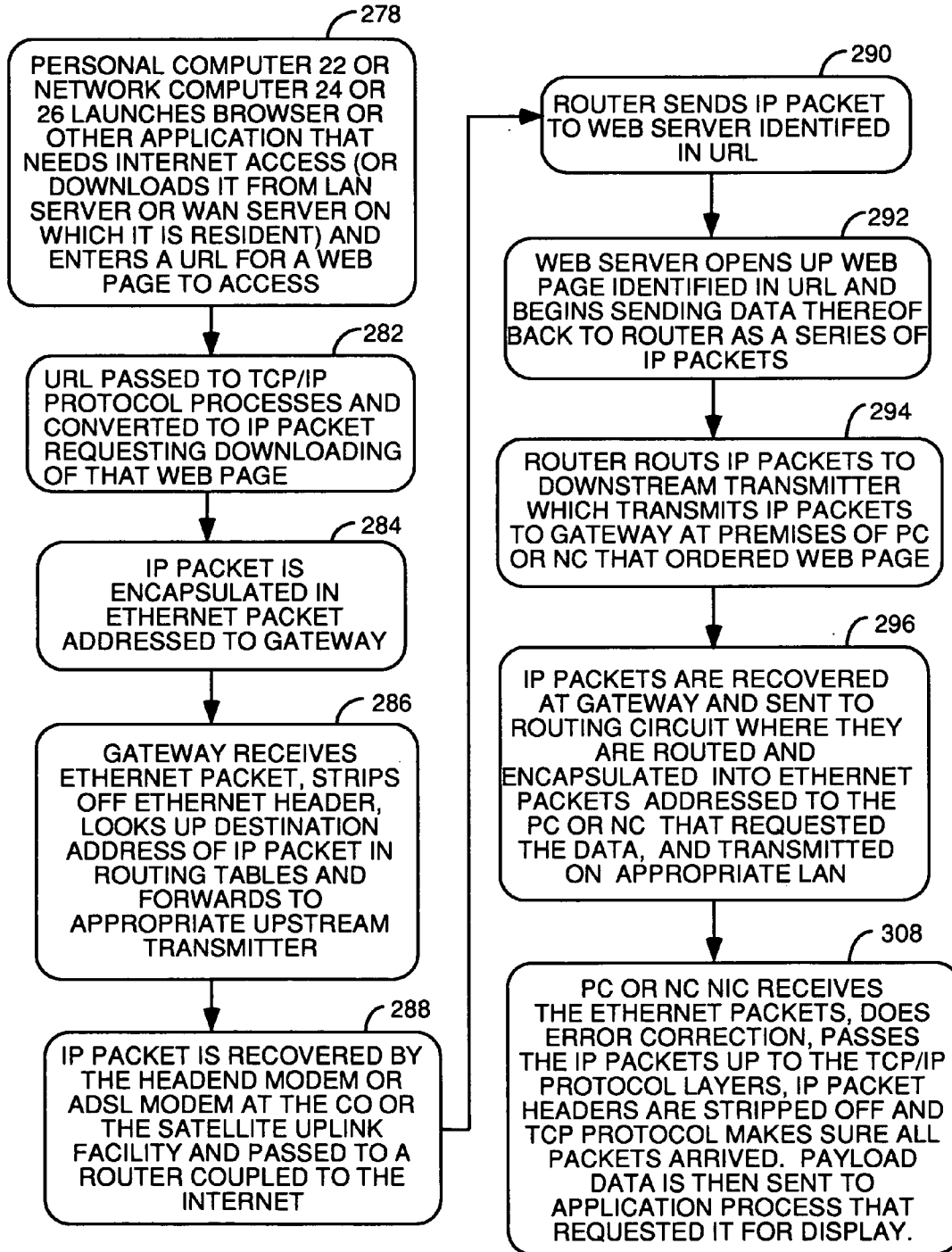

FIG. 7

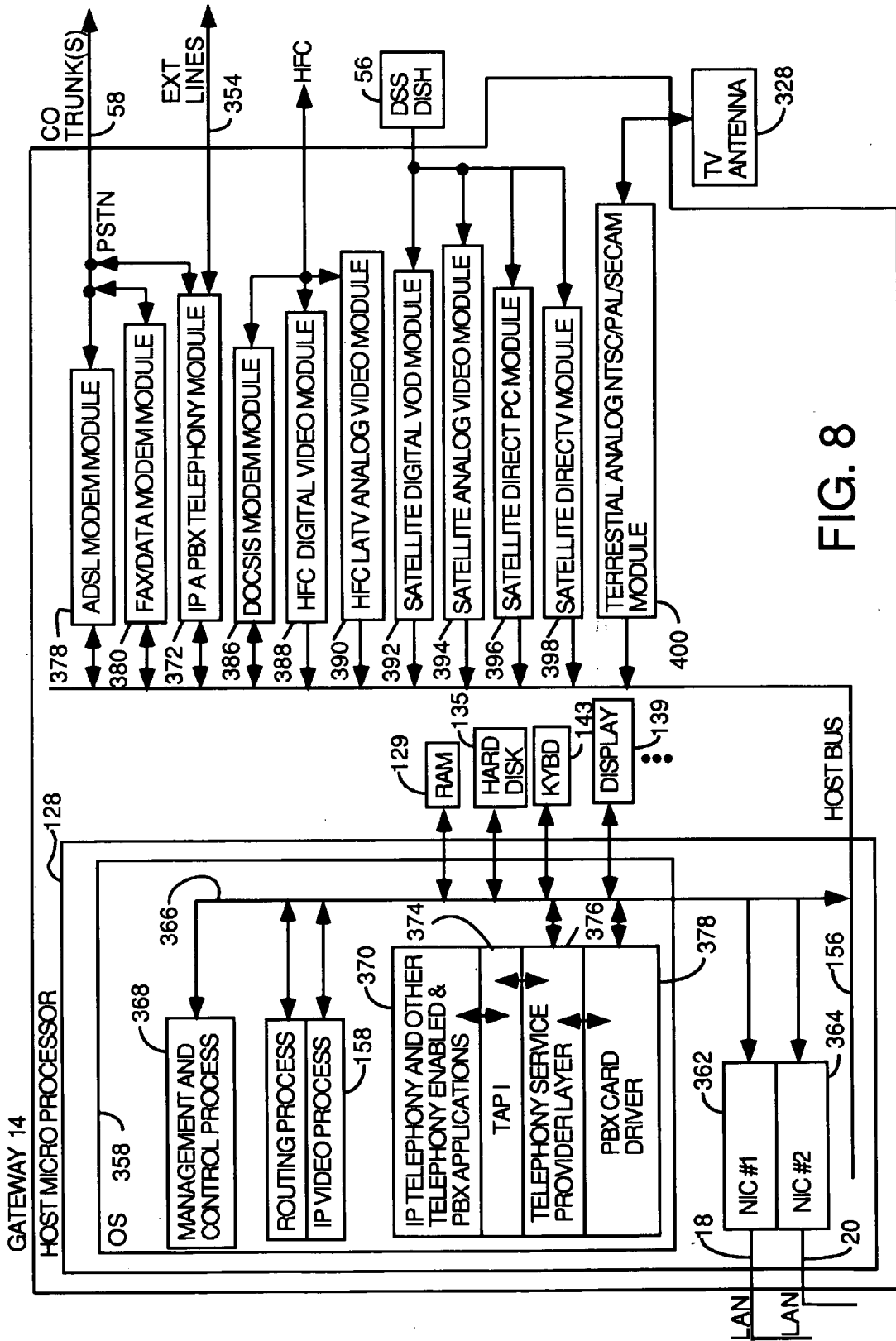

FIG. 8

**HOME NETWORK FOR ORDERING AND
DELIVERY OF VIDEO ON DEMAND, TELEPHONE
AND OTHER DIGITAL SERVICES**

FIELD OF USE

[0001] The invention finds applicability in the distribution of digital video on demand services and other digital services throughout a consumer's location.

[0002] With the advent of cable modems, there is the ability to deliver digital data at high rates from content providers and the internet over cable TV systems. Many different services will be delivered digitally, one of which is video on demand and high definition TV digital data. Another digital service which is useful at least for business establishments is video conferencing. Other digital services that will be becoming more and more useful in the future are high speed contact with the corporate LAN from home for telecommuters, high speed internet access, distance learning, multimedia presentations to remote and/or dispersed audiences, etc.

[0003] The development of cable modems has enabled the delivery of high speed data over 10 MB/sec channels to customer premises over hybrid fiber coaxial cable TV distribution networks. But once the digital data reaches a customer premises, it still must be distributed and converted to a proper format for use by the user on a TV, a telephone, a video phone, a computer, a network computer a FAX, a DVD recorder and other peripherals that will be developed in the future.

[0004] Concurrently, the telephone companies have developed digital subscriber line technologies such as Asymmetrical Digital Subscriber Line (ADSL), High Bit Rate Digital Subscriber Line technology, ISDN and ISDL, Rate Adaptive Digital Subscriber Line (RADSL), Symmetric Digital Subscriber Line (SDSL), Very High Speed DSL (VDSL). These different technologies are described in Muller, *Desktop Encyclopedia of Telecommunications*, p. 93-95 (McGraw Hill 1998) ISBN 0-07-044457-9, and Clayton, *Illustrated Telecom Dictionary*, (McGraw Hill 1998) ISBN 0-07-012063-3, and Horak, *Communications Systems and Networks, Voice, Data and Broadband Technologies*, (M&T Books, Foster City, Calif. 1997) ISBN 1-55851-485-6, the entirety of all these publications being hereby incorporated by reference. These digital subscriber line technologies will soon be capable of delivering digital voice, data and image information from various servers as well as via high speed internet access to the subscriber premises over standard telephone copper twisted pairs which are already in the ground and which everybody already has. Some of these technologies are fast enough to also deliver video on demand, which typically requires about 2 megabits/sec data rate.

[0005] The also were introduced in 1994, digital broadcast satellite services (DBS) such as DirecTV (offered by Hughes Electronics and Thomson Multimedia). DBS services already can or soon will provide video on demand, internet connectivity and multimedia applications all with the high picture quality that digital technology provides. Video conferencing via DirectPC service may also soon be provided. DirecTV delivers 175 channels of digital-quality programming through an 18 inch dish antenna, a digital set-top decoder box and a remote control. An access card allows

billing information to be captured by the set-top decoder box and downloaded by the PSTN to a billing center for pay-per view programs ordered by a user. In addition, DirecPC technology allows high speed (400 KB/sec) internet access to PCs in the customer premises using the DBS dish and coaxial cable distribution network. An expansion card couples the PC's I/O bus to the coaxial cable distribution network of the DBS system. A modem is used by the PC to make a dial up connection to the internet service provider (ISP) which then sends internet data to the PC via an uplink to the satellite and then down to the user's dish.

[0006] One problem that consumers of digital data delivery services will soon face is as follows. There is great uncertainty as to which subscription data delivery services will provide the most reliable, best performing and least expensive version of each type service. Thus, there is a need for a way for a user to be able to couple to all the different subscription service data delivery options available to her and to distribute the data cheaply throughout her premises to all the different peripherals that need it like television sets, computers, telephones, video phones etc. To do this, it will be necessary to have some sort of circuit that can interface with all the different subscription service digital data delivery networks and at least one local area network running throughout the user's home and do any necessary protocol conversions and packet, cell or frame reassembly and encapsulation into packets of the type used on the LAN.

[0007] ADSL routers such as the Remote 810 ADSL Router manufactured by 3Com currently exist. These routers can couple an Ethernet local area network to ADSL lines so that POTS voice conversations can occur simultaneously while searching the internet. The Remote 810 ADSL Router has an integrated 4-port 10Base-T hub to couple multiple PCs can share the same ADSL line. The router supports up to 16 simultaneous concurrent connections to multiple destinations on the internet and can perform bridging functions. 3Com also manufactures SDSL routers like the OfficeConnect Remote 840 SDSL which can support applications that require high bandwidth in both directions such as video conferencing, remote training, Web hosting, e-commerce and other multimedia applications.

[0008] Other prior art, such as the 3Com PathBuilder S700 WAN switch, exists which concentrates, aggregates and switches traffic over wide area networks. The PathBuilder S700 WAN can converge voice, video and data applications—including Frame Relay, ATM and SONET—onto a common network. Up to 100 interfaces are supported. Advanced traffic management features such as traffic shaping, priority queuing and multicasting, guarantee the right amount of bandwidth for each application and let you build and manage your WAN infrastructure. The switch features a future-proof chassis with a modular construction to protect the initial investment and provide a migration path to accommodate future growth. The switch has individual application modules that provide native interfaces to a variety of campus networking technologies such as LANs, muxes, routers, SNA applications, business video and PBXs. Each application module adapts communications traffic to the cell-based backplane and transports it across the PathBuilder S700 switch cell bus to the appropriate trunk interface connections which offer a comprehensive range of campus and wide area interface types. A T1/UNI module supports Inverse Multiplexing for ATM at speeds ranging from 1.5

Mbps to 16 Mbps. An 18-slot chassis supports migration to T3/E3 or OC-3 services as bandwidth requirements increase. Distributed processing implemented by placing a RISC processor on each application module to provide scaleable performance and wire speed communications.

[0009] However, the 3COM Pathbuilder S700 WAN Switch lacks the capability to interface with ADSL lines, cable modems, satellite dishes, wireless local loops, terrestrial microwave links or other subscription network services that may become available in the future such as digital data delivery over the power lines. The 3COM Pathbuilder S

[0010] 700 WAN Switch is a professional level switch which is not affordable for the average home network consumer. In short, it is believed that no gateways or routers currently exist which can couple a local area network such as an Ethernet to each of the public service telephone network, and which embody and combine the technology of ADSL modems, cable modems, and satellite DirectPC decoder boxes with IP video and IP telephony interfaces and switching, routing and protocol conversion capability.

[0011] In the current climate of deregulation, fierce competition for provision of telecommunication services to customers has arisen. Many alternative distribution networks for digital data have either already been developed or under development. For example, in the near future, the digital data delivery services just described that are delivered by the PSTN and CATV HFC distribution facilities will also be competing with wireless local loop delivery networks provided by Personal Communication Service (PCS) companies and data delivery services under development by the electric power utilities.

[0012] The problem is that the consumer has no way to know which services will provide the most reliable, highest quality and least expensive delivery mechanism for telephone and FAX service, e-mail, distance learning, video conferencing, high speed world wide web access, video on demand, remote LAN for telecommuters and multimedia services. Further, over time, as each of the subscription networks evolve and competitive pressures force lowering of prices, it is possible that what was once the best provider of, for example, video-on-demand (hereafter VOD), is no longer the best provider but some other technology is. As another example, ADSL does not have sufficient upstream bandwidth if video telephony becomes a popular application whereas cable modems do. However, variable bit-rate MPEG2 and advances in video compression technology might save ADSL if video conferencing becomes big, and High Speed ADSL may be adequate to service this application. The problem this raises for consumers is that they do not want to invest in technology for their home networks that only interfaces to ADSL or cable modems and then be faced with the prospect of an expensive replacement of their home network equipment in order to interface their LAN with a new subscription service digital data delivery network.

[0013] Another example involves supplying Plain Old Telephone Service (POTS) to consumers via cable modem versus ADSL. Cutting of a CATV line in the street or losing an above ground cable during a windstorm will cut service to the entire neighborhood. That means that everybody in the neighborhood who obtains their telephone service via cable modem, will be left without phone service until the break is repaired. In contrast, ADSL is a point-to-point technology

which causes only one customer to lose phone service if her line is broken. A well maintained HFC CATV network may obviate some of these problems, but that is unclear because there has not been a great deal of field experience gained yet in POTS over HFC.

[0014] Thus, a consumer will not know whether to buy a gateway that can interface to an ADSL modem or an HDSL modem or a cable modem until the bugs are worked out and competitive factors come into play and make it clear which delivery network provides the best, lowest cost service for this application.

[0015] However, one thing is clear: the above identified services will be in demand, and the consumer would like to be able to take advantage of the best delivery mechanism for each service and be able to switch easily between delivery services as competition forces adjustments in prices.

[0016] Since these services will arrive on many different media, possibly in many different packet formats or using many different protocols, a problem is created for the user in deciding what type of home network data distribution system to buy and install. For example, there may be different packet and cell sizes and different header structures, different type of compression and different protocols will be used. The user only wants to inexpensively and conveniently distribute data encoding each of these services throughout her premises to the various peripherals like digital VCRs, DVD recorders/players, TVs, FAX machines, computers, telephones etc. that need the data without having to have a different gateway and local area network for each type of data delivery service. Further, the user may want to use ADSL for some services and cable modem for other services and wireless local loops or satellite downlinks or some other data delivery network option for other services.

[0017] A related problem is in the area of videoconferencing. Currently, videophone offered by AT&T have been a commercial failure because of the low picture quality of 2 frames per second deliverable over standard twisted pairs. ISDN circuits can be used for videoconferencing and ISDN videophones are available, and their details are hereby incorporated by reference. However, the higher cost of ISDN and its lesser availability to all homes has slowed the acceptance of ISDN videoconferencing. Switched 56/64 Kbps circuits can also be used for video conferencing by bonding or grouping into multiple channels. Switched 384 Kbps connectivity can also be provided on the basis of fractional DS1 or through ISDN PRI channels in a channel group known as an HO. However, the cost and availability issues that are slowing ISDN teleconferencing also exist for switched 56/64 and switched 384 Kbps services as well.

[0018] Likewise, DS-1 facilities support full-motion, high-quality videoconferencing over dedicated networks at rates of up to 2.048 Mbps for E1 and 1.544 Mbps for T1. However, DS-1 facilities are costly and not widely deployed and, although they are affordable for large organizations with DS-1 backbones, they are out of reach for the home network consumer.

[0019] Broadband networks such as ADSL, B-ISDN, HFC and cable modems, satellite etc. are likely to be much more convenient and affordable ways of delivering videoconferencing services via ATM operating at DS-1 or DS-3 or higher speeds.

[0020] Thus, a need has arisen for a system which interface to many different subscription service data delivery networks and can distribute digital data throughout a customer premises in an economical fashion to all the peripheral devices that need the data using a uniform protocol and addressing scheme. Preferably, the system will have an economical and reliable local area network on the consumer premises side and have the flexibility to couple to many different subscription service data delivery network media types and translate from whatever packet/cell/frame type and protocols are used by the data delivery network without substantial expense to reconfigure or buy new equipment or software each time a data delivery network option appears that is better, cheaper or more reliable than the consumer's current service provider.

SUMMARY OF THE INVENTION

[0021] A home network system within the genus of the invention would have a host bus and host computer programmed to do management and control functions and a routing function, one or more local area network interfaces and one or more external network interfaces.

[0022] An important subgenus within the overall genus would be characterized by a modular, expandable gateway construction which interfaced any one of a number of external networks and subscription services to peripheral devices in a customer premises coupled to the gateway by one or more local area networks. Such a modular gateway species would have as many shared components as possible including a network interface to drive a local area network that communicates digital data of various services and a routing process and possibly an IP packetization process running on the host computer. However, expandability would be provided by interfacing the gateway to one or more external networks using modular plug-in expansion circuits or modules to implement the unique interfaces with various types of data delivery networks. Some of the expansion modules are receivers capable of receiving analog signals and digitizing and compressing them and supplying the compressed data to said host computer. Others are receivers for receiving and recovering video and other data in digital form which has been modulated onto a downstream carrier for transmission to said customer premises and supplying the recovered digital data to said host computer. Others of the expansion modules are transceivers capable of receiving analog signals and digitizing and compressing them and supplying the compressed data to said host computer or receiving and recovering video and other data in digital form which has been modulated onto a downstream carrier for transmission to said customer premises and supplying the recovered digital data to said host computer. These transceivers include an upstream transmitter for receiving digital data from said host computer, preferably as an IP format packet, and transmitting it outbound on an external network to a headend modem, a DSL central office, a server connected to the internet at the location of an internet service provider via a dialup connection or to a satellite uplink facility via a dialup or direct connection.

[0023] For example, in a species using an Ethernet local area network, the gateway would have a shared Ethernet Network Interface Card (hereafter NIC) and an Ethernet protocol stack. This hardware and software drives one or more 10BaseT, Fast Ethernet, or 100BaseT local area net-

works coupled to the gateway that function to distribute downstream data to various devices such as telephones, computers, televisions, FAX machines etc. scattered throughout the customer premises. The local area network(s) also collect upstream data from the various peripherals spread throughout the consumer premises and transfer this data to the gateway. Other shared functions would include the power supply, bus structure and the host processor and routing process, an IP packetization process, possibly MPEG compression and decompression, possibly DES or other encryption and decryption processes, MAC layer and/or IP address resolution, and, possibly, IP telephony and/or PBX processes to control IP telephony and/or PBX expansion modules. Some data delivery networks use MPEG compression and others do not and some services use encryption and others do not. Thus, depending upon the external network and subscription or other service involved, the expansion module that interfaces the gateway to the external network may include whatever compression/decompression, address resolution and encryption/decryption functions necessary to successfully communicate with those data delivery networks.

[0024] Generally, the plug-in external network interface modules that interface to each external network will include all those circuits and software processes such as protocol stack peculiar to communication with that particular external network and a particular subscription service. These circuits can include any necessary line coding and decoding, demodulation, detection, demultiplexing, encoding, compression, access control and other circuitry such as decryption and re-encryption circuitry necessary for receiving data from or transmitting data to the particular external network and subscription service the interface is designed to work with.

[0025] One of the advantages of the modular structure is, for example, if a consumer is getting their digital data delivery services by ADSL using one particular ADSL modem line coding, and another service provider with a different line coding provides a better service which the consumer wants to take advantage of, the consumer need only buy an ADSL interface board having the appropriate line coding to switch services and does not need to buy an entirely new gateway.

[0026] However, the modular construction is not an essential element of the invention. For example, the teachings of the invention also contemplate a subgenus of simple stand-alone, nonexpandable gateways which only include one or more external network interface circuits which are always present. These types of gateways can be used by customers who know exactly which external networks and subscription services they will use and who have no need or desire to change. **FIGS. 4A and 4B** are supposed to symbolize a species within this subgenus which happens to include external network interfaces to an ADSL line, C-band and Ku band satellite dishes, an HFC drop line and a terrestrial TV antenna.

BRIEF DESCRIPTION OF THE DRAWINGS

[0027] **FIG. 1** is a diagram of a prior art connection between the internet and a home local area network through a cable modem and the HFC of a CATV system.

[0028] FIG. 2 is a diagram of a prior art connection between the internet and a home local area network through an ADSL modem.

[0029] FIG. 3 is a diagram of a home network having a gateway within the genus of the invention which couples any one of a number of different subscriber service data delivery networks which are external to a customer premises to one or more local area networks that deliver digital data from said external networks to one or more devices in said customer premises coupled to said local area networks. The gateway does the necessary protocol conversions and translations between the protocols and packet formats of the local area network and the protocols and packet formats of the subscriber service data delivery external networks.

[0030] FIGS. 4A and 4B are a detailed diagram of a gateway having ADSL, satellite, cable and broadcast TV antenna interface circuitry.

[0031] FIG. 5 is a block diagram of a video adapter for coupling a local area network to a television.

[0032] FIGS. 6A-6E are a flowchart of a pull technology video on demand process.

[0033] FIG. 7 is a flowchart of a wideband internet access process.

[0034] FIG. 8 is a block diagram of a modular construction for the gateway.

DETAILED DESCRIPTION OF THE PREFERRED AND ALTERNATIVE EMBODIMENTS

[0035] FIG. 1 is a diagram of a prior art connection between the internet and a home local area network through a cable modem and the HFC of a CATV system. The internet is shown as cloud 11. An IP router 13 in the headend facility 15 of an internet service provider bidirectionally couples IP packets to the internet using the TCP transport protocol. An optional local proxy server 17. The proxy server is coupled to the IP router and provides local content as well as caching certain very popular web pages such as Yahoo or CNN news etc. so that they can be sent to cable modem subscribers with greater speed. A control circuit 19 concentrates all IP traffic from the subscribers coupled to the HFC network and sends it to the IP router 13 and distributes packets from the IP router to the various fiber optic links of which line 21 is typical. The fiber optic links couple the headend to fiber nodes of which node 23 is typical. Each fiber node couples the fiber optic link to a coaxial cable feeder branch of which branch 25 is typical. Each feeder branch has at least one bidirectional amplifier, of which amplifier 27 is typical. Each feeder branch is coupled to a plurality of drop lines, of which drop 29 is typical, which couples the branch to a cable modem at the subscriber premises. Cable modem 31 is typical and can be any of the cable modems identified below. The cable modem has a 10Base-T output port which is coupled to an Ethernet LAN 33 which runs throughout the home to peripherals such as TV 39, telephone 37 and personal computer 35. A typical example of cable modem 31 is the U.S. Robotics Cable Modem CMX. This modem will work on any cable system that complies with the MCNS data-over-cable specification. This cable modem comes with an EtherLink network interface card and is compatible with the Windows and Macintosh operating systems.

[0036] Referring to FIG. 2, there is shown a prior art connection between the internet and a local area network in a home via the telephone system using ADSL modems. The internet 11 is coupled to IP router 13 via DS 1 (1.544 Mbps supporting 5 or more continuous users or up to 55 users with 10% usage), DS 3 (45 Mbps supporting up to 1500 subscribers) or OC-3 connections. Optional proxy server 17 serves the same function is served in the cable modem system of FIG. 1. ADSL modems 41 and 43 at the subscriber premises 45 and central office 47 couple to the twisted copper wire pair that was originally used for POTS. A POTS splitter, not shown, forwards the analog voice transparently to the POTS central office in a frequency below the ADSL domain. The ADSL modem 41 connects directly to the Ethernet port of a personal computer or to an Ethernet hub. The access switch 53 serves to concentrate access lines from the ADSL modems such as 43 into router ports of IP router 13. Access adapter 53 is likely to include ATM switch fabric. The ADSL modem 41 can be the 3Com HomeConnect ADSL Modem Ethernet or any equivalent ADSL modem.

[0037] Referring to FIG. 3, there is shown a diagram of a home network having a gateway within the genus of the invention which couples any one of a number of different subscriber service data delivery networks which are external to a customer premises to one or more local area networks that deliver digital data from said external networks to one or more devices in said customer premises coupled to said local area networks. The gateway does the necessary protocol conversions and translations between the protocols and packet formats of the local area network and the protocols and packet formats of the subscriber service data delivery external networks. The home network is useful for distribution of digital data that encodes video on demand, distance learning, video conferencing, telephone service, internet web pages and FTP download files, e-mail and other digital subscriber services to multiplied devices over one or more local area network that runs throughout a customer premises. Digital data or analog signals implementing the subscriber service (subscriber service is used loosely to mean all signals whether analog or digital transmitted to the customer premises via an external network of any type including a TV antenna) is transmitted to the customer premises. Gateway 14 converts the incoming signals to digital data in Ethernet packets and transmits it to the requesting device coupled to the local area network.

[0038] The gateway 14 functions to do all the physical layer interfacing and protocol conversions necessary to couple one or more local area networks that run through the customer premises to digital data distribution services delivered via the Hybrid Fiber Coax (HFC) of a cable television system, or a digital satellite data distribution network or the phone lines of the public service telephone network. Hereafter, these digital data delivery networks external to the customer premises will be called the subscription networks or the digital data delivery networks even though some or all of them may also deliver analog signals as well as digital data. For example, the cable TV subscription network 16 will deliver analog CATV signals in addition to the digital data carried on its upstream and downstream carriers. Likewise, the satellite dish 56 will deliver broadcast TV signals as well as digital data modulated on the downstream carrier. The Public Service Telephone Network (PSTN) telephone lines 58 will also deliver analog telephone signals in addi-

tion to digital data modulated onto the upstream and downstream carriers of the ADSL service.

[0039] The gateway 14 is typically a Pentium or Celeron class personal computer host with protocol conversion and switching control programs that cooperate with the operating system to control the operations of various interface circuits and having one or more network interface circuits that drive the media of the local area network(s). In some embodiments, the interface circuits can be built on the motherboard with the host microprocessor. However, in the preferred embodiment, each interface circuit is a separate expansion card that plugs into the system bus of the host and has a connector suitable to interface with the physical media of the particular digital data delivery service. Likewise, the network interface to the local area network(s) can be an expansion card. However, it is preferable for the local area network interface circuit to be built into the motherboard so as to not consume an expansion slot. In this modular type construction, the circuits and software that are common to all the expansion modules that interface to the various subscription networks are shared by the expansion module interface circuits. Thus, the host microprocessor, hard disk, RAM, CD-ROM/DVD, power supply, network interface circuits for the LAN(s), display and keyboard are all shared as are the operating system, management software and any protocol conversion software layers that are common to all network interface circuits. Likewise, the gateway 14 is going to have a packet switching process and a crossbar switch or other switching circuitry controlled by the switching process to route packets received from the subscription providers to the appropriate LAN and vice versa based upon the IP or other addresses in the headers of the packets. These two elements can also be shared by the expansion module interface cards as the switching services need to be shared by all the subscription network interface cards in the gateway. The circuits and software that are specific to any particular subscription network such as MPEG compression or decompression, tuning, detection and demodulation, carrier and clock recovery, video decoding, A/D or D/A conversions etc. are located on the expansion module interface card dedicated to that subscription network.

[0040] This preferred modular construction has two significant advantages. First, it protects the subscriber's investment in the gateway by providing flexibility to couple the gateway to any subscriber network that turns out to be the most reliable, least expensive, most flexible or easiest to use or least aggravating subscriber network for supplying any particular digital data based service desired by the user. For example, if ADSL turns out to be the best provider of telephone and video telephony services, but HFC turns out to be the best provider of video on demand or distance learning services, and these are the only services the user is interested in purchasing, the user can simply buy expansion modules to interface with these two subscription services. There is no need to invest in a gateway that has hardware and software to provide high speed internet access as well as these other services since the user is not interested in purchasing high speed internet access. This first advantage also extends to the situation where the user later changes her mind and decides that high speed internet access is useful, but determines that satellite delivery by DirectPC™ is the best way of obtaining this service. In such a case, the user

does not have to buy an entirely new gateway, but can simply buy an additional modular expansion card for interfacing to a satellite dish.

[0041] The second advantage of the modular construction of the gateway is the property it has of protecting the subscriber's investment in the gateway by decoupling the physical structure and software of the shared components of the gateway from changes in the particular subscription networks. As these subscription networks evolve, there are likely to be changes in the protocols, physical media, packet structure etc. which are unpredictable in nature. Further, it may evolve over time with competitive forces similar to those acting on the long distance carriers that competition alters the picture as to which subscription network is the best provider of each particular service in which the subscriber is interested. If ADSL no longer is the best provider of telephony services, and the HFC networks offer a better deal, the consumer does not have to buy an entirely new gateway, but can simply remove the ADSL interface card and substitute a cable modem card to interface with the HFC network if a cable modem card is not already present. Likewise, if ADSL with Carrierless Amplitude/Phase modulation (CAP) give way to Discrete Multitone (DMT) modulation as the new standard, the user can simply swap out the CAP based ADSL expansion module for a DMT based module.

[0042] The structure of one embodiment of the gateway 14 will be discussed in more detail later. However, the genus of gateways 14 which are within the teachings of the invention is defined by the following characteristics which all will share:

[0043] a programmed host computer with an operating system, and one or more protocol conversion processes and a switching control process that controls a packet switch to route packets between the one or more subscription service networks and the local area network(s) to which the gateway is coupled;

[0044] one or more interface circuit for the particular local area network(s) coupled to the packet switch to drive packets out onto the physical media of the LAN(s);

[0045] either a single interface circuit that can interface to all of HFC, PSTN and satellite digital data delivery networks which is either on the motherboard of the host or separate from the motherboard and coupled to the host system bus, or a plurality of expansion slots for coupling individual subscription network interface modules to the host system bus as desired so that each module can share the common facilities of the host needed to support the module; and

[0046] wherein the common elements of the host that can be shared by all the subscription network interface circuits for all the subscription networks to which the gateway is coupled are shared, with examples of such shared circuits being: the host microprocessor, hard disk, RAM, CD-ROM/DVD, power supply, network interface circuits for the LAN(s), display and keyboard, the operating system, any management software and any protocol conversion software layers that are common to

[0047] all network interface circuits and a packet switching process and a crossbar switch or other switching circuitry.

[0048] The gateway **14** will have a cable modem circuit either on a modular expansion card or as part of the subscription network interface circuits board. This cable modem circuitry can be any of the cable modems that are known in the prior art which are identified herein or any new cable modem design that surfaces after this application is filed since the details of the cable modem are not believed at the present time to be critical to the invention.

[0049] Likewise, the gateway **14** will have as part of its interface circuit board or as an expansion card module, an ADSL modem (or SDSL or HDSL modem) to receive incoming digital data modulated onto a downstream carrier and output it as Ethernet packets on LAN(s) **18** and **20**. In some alternative embodiments, LANs **18** and **20** could be ATM LANs or one could be ATM and the other Ethernet or some other technology such as Fibre Channel Arbitrated Loop with suitable adjustments in the gateway **14** to packetize the data properly and use appropriate circuitry and protocols at all levels from the physical layer, MAC and network or routing layers up to the application layer for the particular LANs in use. ATM LAN switches and routers are available in the prior art and the details of their construction are hereby incorporated by reference.

[0050] Likewise, the ADSL modem receives Ethernet packets with digital data encoding voice, pictures, video etc. and modulates that data onto an upstream carrier. ADSL carves up the local loop bandwidth (the bandwidth of the twisted pair telephone line from the consumer premises to the Central Office) into several independent frequency channels suitable for any combination of services including voice, ISDN, VOD programming and interactive gaming. Downstream data rates vary from 1.544 to 6.144 Mbps with upstream rates from 16 to 640 Kbps. The gateway ADSL interface circuit will also have a voice splitter if regular analog telephone are to be supported in addition to the LAN-connected video phones **60** and **62** or other data-consuming phones or FAX machines like FAX **64** which receive and transmit voice and pictures or caller ID or other data in digital form. Such other data can include such things as a background information file on the person identified by caller ID data transmitted by an application on the PC **22** which supports the phones. Any conventional ADSL (or SDSL or HDSL) modem design such as the known ADSL modem manufactured by 3COM (specifically identified below and incorporated by reference herein) may be used for the PSTN ADSL interface circuitry or the ADSL expansion module as the details of the ADSL interface circuitry are not believed to be critical to the invention. The 3COM ADSL modem couples to a twisted pair carrying ADSL services and has an Ethernet 10Base-T output for coupling to the LAN(s) **18** or **20** through the shared packet switching circuitry of the gateway.

[0051] The gateway **14** also includes as part of its subscription network interface circuit board or as part of its satellite network expansion module a decoder box. This satellite decoder box is of known design suitable to receive, demodulate, demultiplex, detect and decompress (if necessary) digital data transmitted on a downlink to satellite dish **56**. This digital data may be transmitted via a service such

as DirectPC or other satellite-based, digital data delivery services which may become available in the future, and the interface circuitry necessary to receive digital data transmitted to a particular PC via satellite is known in the DirectPC application, and is hereby incorporated by reference. Typically, such satellite interface circuitry includes a tuner, a QPSK demodulator, a transport demultiplexer and a conditional access circuit. If the satellite interface circuit is being used to receive digital video signals that are compressed, the satellite circuitry may include circuits to decompress the digitized video back to its original state (or close to its original state if lossy compression such as MPEG is used). However, since uncompressed broadcast quality standard NTSC video requires a bit rate of slightly over 221 Mbps, whether the satellite interface circuitry of the gateway includes decompression circuits depends upon the bandwidth of the local area network(s) coupled to the gateway. If the LAN(s) are 10Base-T or 100Base-T, the video digital data will be left compressed and can be transferred over the LAN(s) with quite acceptable quality at T1 speeds of 1.544 Mbps. MPEG compression and decompression is known in the art and is incorporated by reference herein. MPEG compression is lossy compression which uses: a 7-tap filter for averaging 7 neighboring pixels or lines; color space conversion; scaling to the presentation resolution before digitization; transforms such as the Discrete Cosine Transform, vector quantization, fractal transform and wavelet compression; and quantization or compaction encoding to reduce the number of bits needed to represent a color pixel such as run-length encoding, Huffman coding, and arithmetic coding; and interframe compression to transmit only the pixels that change between frames. Many compression standards exist such as Px64, JPEG, MPEG 1 and 2 (MPEG 2 with transmission rates of 4 to 100 Mbps is already in use for digital video transmission via satellite services such as DirecTV) and MPEG 4 (a low bit rate standard intended for videophones and other small screen devices). The compression and decompression circuitry for all these standards is hereby incorporated by reference.

[0052] Further, the satellite interface circuitry or satellite expansion module should also include a convention telephone modem for making dial up access to the internet via the PSTN for upstream data transmissions through the server of the internet service provider. Downloads from the internet or a video server or some other digital service server are beamed up to the satellite and retransmitted on the downlink addressed to the specific user that requested the downlink. All other decoder boxes coupled to satellite dishes that received the same broadcast reject the packets so received as not addressed to them.

[0053] In the embodiment shown in FIG. 3, a cable modem **12** is shown externally to the gateway with the output IP or Ethernet packets encapsulating IP packets or ATM cells on bus **16** for coupling into the packet switching process inside the gateway. The preferred embodiment however is as shown in FIGS. 4A and 4B with the cable modem circuitry inside the gateway as shown at **70**. The particular cable modem shown at **70** is labelled as DOCSIS 1.2 compatible, but it can be any known cable modem design as can the external cable modem.

[0054] Referring to FIGS. 4A and 4B, we turn now to more specific information about each of the possible subscription services digital data delivery networks and the

interface circuitry in the gateway **14** needed to couple each said external network to the LAN at the customer site. The gateway **14** can be a standalone circuit with all the interface circuits needed to interface to one or more external networks included as a permanent part thereof with no plug-in expansion capability as opposed to the preferred modular construction shown in **FIG. 8** where external network interface circuits may be added as needed.

[0055] First, digital data services may be delivered by a coaxial cable **10** which represents the drop line in a cable TV HFC network (not shown). The cable TV network has a head end modem (not shown) which couples the HFC cable CATV plant to wide area networks such as the internet as well as the public service telephone network (hereafter PSTN) through one or more routers, bridges or gateways (not shown). The head end modem may also couple the HFC to local servers such as VOD servers.

[0056] Digital data encoding video signals, telephone service, data being received from the internet etc. is modulated by the head end cable modem onto one or more downstream channels for simultaneous transmission on the HFC cable plant with regular analog cable TV programming. The cable TV channels each have their own frequency so as to not conflict with each other. The downstream digital services data is modulated onto a carrier that has a frequency that does not conflict with the frequencies of the cable TV programming nor with upstream data which is modulated onto a different upstream carrier frequency. Data from different sources is multiplexed on both the downstream and upstream channels by any known means including time division multiplexing, code division multiplexing, synchronous code division multiplexing or frequency division multiplexing.

[0057] Digital data can be delivered over the HFC using Asynchronous Transfer Mode (ATM) or ATM over B-ISDN type services adapted for HFC and the particular type of transmitters, modulation and multiplexing being used. ATM and B-ISDN (Broadband ISDN) are inexorably linked, and there are a plurality of standards set by ITU-T that are in existence which are incorporated by reference herein. Those standards are: 1.113; 1.121; 1.150; 1.211; 1.311; 1.321; 1.327; 1.361; 1.362; 1.363; 1.413; 1.432; 1.555; and 1.610. ATM Forum Implementation Documents of significance that are incorporated by reference herein are: ATM User-Network Interface (UNI) Specification for PVCs; ATM Broadband Inter-carrier Interface (B-UNI) Specification and ATM Data Exchange Interface (DXI) Specification; Internet Engineering Task Force Requests for Comment (RFC) that are incorporated by reference are: RFC 1483: Definition of Multiprotocol Encapsulation over AAL5; and RFC 1577: Definition of Internet IP over ATM.

[0058] ATM is the delivery mechanism of choice since its small 48-octet payload and 5-octet header in each cell lends itself well to video, image, facsimile, voice or data. Further, the fixed cell size gives routers and switches the advantage of predictability, as compared to a variable length frame. These two considerations yield decreased delay as data moves through the switching system and across the transmission links in frequent little blasts. No long frames need to be transmitted tying up switch ports and thereby causing delays for frames from other sources that need to use the same ports. ATM also has the advantage of being able to

adjust the amount of bandwidth required to support a session during the session. However, ATM networks do not provide either error detection and correction or protocol conversions. Those functions are left up to the user.

[0059] Likewise, digital data may be delivered over HFC using Discrete Multi Tone (DMT) technology typically used in ADSL but adapted to HFC and the particular type of transmitters, modulation, multiplexing being used. DMT is a new technology developed for ADSL delivered via twisted pairs that uses DSPs to pump more than 6 Mbps of video, data, image and voice signals over todays existing one pair copper wiring, but it could also be used to transmit data over HFC cable plants. DMT provide 4 asymmetric "A" channels at 1.5 Mbps each of which can provide an VCR quality signal and which can be ganged together such that two A channels can deliver a "sports" quality video channel and all four A channels operating together can deliver digital Extended Definition TV signals. DMT also delivers one "H zero" channel at 384 Kbps to deliver Northern Telecom's multirate ISDN Dialable Wideband service or equivalent. This channel can also be used for work-at-home telecommuters for high bandwidth access to the corporate LAN using Northern Telecom's DataSPAN or other frame relay services. DMT also delivers one ISDN Basic Rate channel containing two "B" channels at 64 Kbps and one "D" channel at 16 Kbps. The Basic Rate channels allow access to a wide range of emerging ISDN services without requiring a dedicated copper pair or the expense of a dedicated NT1 unit at home. These channels also permits the extension of Northern Telecom's VISIT personal video teleconferencing services to the home at fractional T-1 rates (P×64). DMT also delivers one signalling and control channel operating at 16 Kbps giving the home user VCR type control over VOD movies and other services including fast-forward, reverse, search and pause functions. Finally, DMT also delivers embedded operations or overhead channels for administration, internal system maintenance, audits etc. All this is delivered without interrupting the POTS service if it is delivered over a copper pair. HFC could also potentially deliver POTS, but without a dedicated pair to each home, such service would be subject to congestion and loss of POTS to entire neighborhoods served by a single cable in case of a failure of the cable.

[0060] In the embodiment shown in **FIG. 3**, digital data on the HFC drop line is recovered by any known cable modem **12**. One example of a suitable cable modem using SCDMA upstream multiplexing is given in PCT publication WO 97/08861, published 6 Mar. 1997, which is hereby incorporated by reference. One example of software and hardware in the cable modem **12** which is Docsis 1.2 compatible is given in the following U.S. patent applications, all of which are hereby incorporated by reference: Ser. No. 09/074,036, filed May 6, 1998 entitled APPARATUS AND METHOD FOR SYNCHRONIZING AN SCDMA UPSTREAM OR ANY OTHER TYPE UPSTREAM TO AN MCNS DOWNSTREAM OR ANY OTHER TYPE DOWNSTREAM WITH A DIFFERENT CLOCK RATE THAN THE UPSTREAM; Ser. No. 09/152,645, filed Sep. 14, 1998, entitled METHOD AND APPARATUS OF USING A BANK OF FILTERS FOR EXCISION OF NARROW BAND INTERFERENCE SIGNAL FROM CDMA SIGNAL; Ser. No. 09/152,643, filed Sep. 14, 1998, entitled TWO DIMENSIONAL INTERLEAVE PROCESS FOR CDMA TRANSMISSIONS OF ONE DIMENSIONAL

TIMESLOT DATA; Ser. No. 09/337,167, filed Sep. 21, 1999, entitled MIXED DOCSIS 1.0 TDMA BURSTS WITH SCDMA TRANSMISSION ON THE SAME FREQUENCY CHANNEL; Ser. No. 08/760,412, filed Dec. 14, 1996, entitled LOWER OVERHEAD METHOD FOR DATA TRANSMISSION USING ATM AND SCDMA OVER HYBRID FIBER COAX CABLE PLANT published as PCT publication WO 97/34421 on 18 Sep. 1997. The PCT publication WO 97/34421 published on 18 Sep. 1997 explains hardware and software for transmitting IP packets received from the internet over HFC using ATM cells and virtual channels to a remote unit cable modem and distributing the data to peripherals via a local area network. Specifically, WO 97/34421 teaches:

- [0061] receiving Internet Protocol packets directed to an entity having an IP address out on a LAN at a customer premises and looking up Ethernet source and destination addresses mapped to that IP address and generating an Ethernet header and appending it to the IP packet;
- [0062] adding RFC 1483 bits and CRC bits and sufficient pad bits to make up an integer number of ATM cell payload section of 48 bytes to result in an AAL5 format packet;
- [0063] parsing the resulting AAL5 packet into a plurality of ATM cell payload sections of 48 bytes each;
- [0064] adding a standard 5 byte ATM cell header to each ATM cell;
- [0065] encoding the PTI field of the ATM cell header with a bit which signals which cell is the last cell in the packet;
- [0066] outputting the ATM cells to a formatter circuit in the head end cable modem as an OC3 TDMA stream;
- [0067] optimizing ATM cell headers to reduce the size of the headers down to two bytes comprising the 16 least significant bits of the VPI/VCI field and encoding the last cell data into two 9th bits of the two 9-bit sections of the downstream optimized ATM cell header;
- [0068] encoding the 9th bits of each of the first eight "bytes" (byte here is used in the sense of a 9-bit entity); parsing the optimized ATM downstream cells into 9-bit bytes and sending them as a TDM stream to the headend cable modem downstream transmitter for transmission (this transmitter can be any conventional transmitter but preferably is an SCDMA transmitter which divides each 9-bit byte into three tribits and interleaves them into elements of an information vector that correspond to virtual channels assigned to the particular modem to which each 9-bit byte is directed, and spreading the spectrum of the information vector using one or more spreading codes assigned to the one or more assigned virtual channels);
- [0069] headend cable modem transmitter encodes the 9-bit bytes and modulates them onto a downstream carrier for transmission over virtual channels from a head end over HFC to a remote unit (RU) cable modem.

[0070] The optimized system uses a two level addressing scheme and a mapping between each logical channel and the assigned RU for that channel. The two byte header in the downstream optimized ATM cell identifies the single logical channel upon which the data is to be transmitted, and this single logical channel corresponds to a single one of the multiple RUs. The Ethernet address of the particular process or peripheral at the RU to which the payload data is to be directed once it arrives at the RU is included as several bytes in the payload data.

[0071] At the RU cable modem (12 in FIG. 3 or 70 in FIG. 4A), the 9-bit bytes are recovered, reassembled into AAL5 packets and encapsulated into one or more Ethernet packets for transmission over the LAN. Specifically, the RU cable modem carries out the following processing:

- [0072] the incoming signals from the cable drop 10 are demodulated, demultiplexed and detected in accordance with whatever multiplexing and modulation schemes that were used by the headend downstream transmitter for the transmission on separate logical channels so as to recover the 9-bit bytes;
- [0073] a formatter circuit finds the ATM cell boundaries by examining the 9th bits for the start code and reassembles the 50-byte optimized downstream ATM cell;
- [0074] the formatter in each RU examines the 2-byte header in each ATM cell to determine if the ATM cell is directed to that RU and discards the cell if it is directed to another RU (RU and cable modem at the customer premises) are used interchangeably herein) and forwards it to a segmentation and reassembly circuit (SAR) as a Utopia data stream if the cell is directed to this RU;
- [0075] the SAR recovers the AAL5 packet boundaries by finding the RFC 1483 bits and the last cell code and reassembles the AAL5 packet and error checks it using CRC bits and stores the corrected AAL5 packet in memory for retrieval by an Ethernet controller and passes a pointer to the packet to the Ethernet controller;
- [0076] the Ethernet controller retrieves the AAL5 packet pointed by each pointer and strips off the RFC 1483 bits and sends the remaining bits as an Ethernet packet (after stripping the RFC 1483 bits, the remainder is an Ethernet header followed by an IP header followed by a payload section).
- [0077] In the embodiment of FIG. 3, if the cable modem 12 has the structure and functionality just described, gateway 14 receives the downstream Ethernet packet on line 16 and simply couples them through a packet switching process on the gateway onto the appropriate LAN subnet (if more than one LAN is used in the customer premises). If only one LAN is used, the Ethernet packets can simply be delivered to an Ethernet Network Interface Card in the gateway for driving out onto the LAN. Likewise, Ethernet packets received from the LAN having IP addresses indicating they are directed to processes coupled to the wide area networks to which cable modem 12 is coupled are routed through the gateway to the cable modem 12. There, they are transmitted on an upstream channel assigned to cable modem 12 and

recovered by the head end modem and coupled to the internet through a router at the head end.

[0078] Other examples of high speed cable modems which could be used for cable modem **12** are given in Azzam, *High Speed Cable Modems*, (McGraw Hill 1997), ISBN 0-07-006417-2, which is hereby incorporated by reference.

[0079] Typically, the local area networks **18** and **20** are 10Base-T phone lines or Cat 3, 4 or 5 UTP (twisted pair) type LANs with any topology. These LANs are inexpensive and there many sources of inexpensive network adapters, hubs and peripherals. The physical media of the LAN(s) **18** and **20** can be provisioned as a twisted pair phone line with which the customer premises is already wired or it can be CAT 5 wiring, or an RF or infrared wireless LAN system, or the coax of the cable TV system that runs through the house can be used for a ThickNet (10Base-5) or ThinNet (10Base-2) LAN. The latter case assumes the coax has been disconnected from the standard CATV drop line feed and is coupled to TV set peripherals only indirectly through the cable modem **12**. However, it is also possible to maintain the connection of coaxial cable running throughout the premises to the HFC cable drop **10** for delivery of FDMA analog CATV programming channels to various TVs and VCRs in the house and use the 10Base-T or wireless LAN for delivery of digital services to the various peripherals through network adapter circuits.

[0080] FIG. 3 shows gateway **14** as coupled to two LANs **18** and **20** one of which is high speed and the other of which is low speed. The high speed LAN may be 100BaseT and is used to deliver high bandwidth consuming services such as video conferencing, video on demand, high speed internet access. There may be one or more LANs coupled to the gateway. If there is more than one LAN, the gateway **14** also provides a routing function to get the Ethernet packets onto the appropriate LAN to which the peripheral having the IP address in the packet is coupled.

[0081] The local area networks **18** and **20** also serve the dual purpose of allowing the computers on the network to communicate with each other and share resources such as shared hard disks, printers etc. For example, PC **22**, which is typically a Windows based personal computer but which may also be a Macintosh or other workstation, can communicate with network computers **24** and **26** to allow files created on the hard disk of PC **22** to be accessed by the network computers or to have documents created on the network computers **24** and **26** stored on the hard disk of PC **22**. Through the gateway **14** and an internal ADSL modem or the cable modem, the network computers can also access the internet and download web pages, send e-mail etc.

[0082] Television set **28** is coupled to the local area network **18** via a network adapter **30** which functions to convert the compressed digital data in received Ethernet packets to video signals on line **32**. The TV may be used in interactive communications so upstream data can be sent through the use of an infrared or RF wireless keyboard **34**. Such data might include the title or number of a VOD movie to be ordered or upstream text to be sent in a multimedia interactive presentation. In addition, an infrared or RF remote control **80** can be used to transmit commands to the network adapter **30** such as play, pause, slow motion, stop, rewind etc. to control video on demand services. Information the consumer wishes to send is entered on the keyboard

and communicated to the network adapter **30** via infrared or RF transmission from the keyboard **34** and/or remote control **80**. The data transmissions are received, demodulated and detected to recover the data and the data is addressed and packetized into IP packets encapsulated inside Ethernet packets by an infrared and/or RF receiver **82** in the network adapter **30** (see FIG. 5 which is a block diagram of the network adapter **30**). The Ethernet packets containing the upstream VOD request data are addressed to the gateway **14**. These packets are launched onto the LAN **20** by a network interface card **84** which does the media access control and physical layer protocols of whatever LAN is in use such as CSMA/CD in the case of Ethernet LANs.

[0083] The IP packet encapsulating each VOD request is addressed to the particular video server which will supply the data. Standard mouse or touchpad type technology in the infrared keyboard and/or remote control **80** sends pointer information to receiver **82** so that the user can request menus from each video server and point to a video selection from each menu displayed on the TV. In one embodiment, the remote control **80** or IR keyboard **34** has function keys that may be pushed to request menus of VOD selections from the satellite, HFC and ADSL video servers. When these function keys are pressed, the receiver **82** converts the request into an IP packet addressed to the appropriate video server requesting transmission of the current menu data. The menu data listing currently available selections is sent as downstream IP packets addressed to the video adapter having the IP address that was the source address of the menu request packet. These IP packets reach the IP video circuit **242** where they are recognized and routed via bus **87** to the 2/3D Graphics circuit **83** which converts the data into graphics data signals on line **85** which will be used to display the menus.

[0084] When the user points to a particular menu selection on a displayed menu, this pointing information is transmitted to the receiver **82** and converted to graphics commands which are transmitted via line **81** to optional 2/3D graphics circuit **83**. The graphics circuit **83** creates graphics for overlay on the TV display, and the pointer information is converted to a graphics image such as a pointer or hand which the user can move on the displayed menu by use of a mouse or touchpad. When the user points to a VOD selection and gives an "order" command, the menu in which the pointer lies is transmitted via bus **81** to the receiver **82** and the position on that menu where the pointer currently is located is determined by graphics circuit **83** and transmitted to the receiver **82**. The menu and current position data so determined are mapped to an IP address of a particular server and a particular VOD selection available from that server. The receiver **82** then uses the IP address of the video server as a destination address and its own IP address as a source address and the requested selection to create an IP packet bearing the VOD request. This packet is then encapsulated into an Ethernet packet addressed to gateway **14** and sent to the gateway via the NIC **84** and the LAN **20**. The gateway strips off the Ethernet header and routes the IP packet to the appropriate video server via the appropriate upstream media for that video server.

[0085] In alternative embodiments, the user may simply type in the number of a category of video from a displayed menu of available categories and the number of a video selection on the displayed menu. The menu number and

program number are then converted into a VOD request IP packet by the receiver **82** and then encapsulated into an Ethernet packet addressed to the gateway **14**. The gateway **14** then processes the VOD request as described above.

[0086] When the upstream VOD request packet reaches the gateway **14**, it is processed by the Ethernet (or other LAN protocol) to IP protocol conversion and routing process (hereafter referred to as the routing circuit) carried out by the host computer circuitry and the software processes symbolized by block **86** in **FIG. 4A** (**FIGS. 4A-4B** together are a block diagram of one embodiment of the gateway). The routing circuit **86** then routes the VOD request packet to the appropriate subscription service data delivery network for delivery to the process/target device named in the IP destination address.

[0087] The routing circuit **86** is shown as a separate logical block in **FIG. 4A** from the host microprocessor **128** and its associated peripherals: random access memory **129**, nonvolatile memory **131** to store the bios, hard disk controller **133** and the hard disk **135** it controls, display adapter **137** and display **139**, keyboard interface **141** and keyboard **143**. All of these peripheral devices are conventional. In an actual circuit, the routing circuit **86** is usually the host microprocessor programmed to do the IP to Ethernet and vice versa protocol conversions, routing table construction and packet routing functions along with any other functions necessary for a router including network interfaces and any other functions required of the routing process described in the flowcharts herein. Descriptions of gateways, routers, the Internet Protocol and IEEE 802.3 Ethernet local area networks are found in Tanenbaum, *Computer Networks, 2nd Ed.* (Prentice Hall 1989) ISBN 0-13-162959-X, and Stallings, *Data and Computer Communications, 4th Ed.*, (MacMillan Publishing 1994) ISBN 0-02-415441-5, which are both hereby incorporated by reference.

[0088] The function of the gateway is to provide protocol conversion, packet format conversion, video, voice and data demodulation, detection and demultiplexing services, conditional access control to prevent non subscribers from receiving services they have not subscribed to. The gateway **14** performs the functions of a cable modem and a set-top decoder box for a satellite digital data subscription service such as DirectPC and performs the functions of an ADSL modem. As part of this interface circuitry, the gateway performs MPEG encoding services, IP video. IP video comprises the process of recovering downstream IP packets and sending them to an input port of a routing process and receiving Ethernet upstream packets and converting them to IP packets and sending them upstream. The gateway also performs IP telephony services (similar to the IP video services except for telephony over the internet) as well as switching and routing services. More details about the structure and operation of the gateway will be included below.

[0089] It is up to the network interface cards of the peripherals to receive the Ethernet packets from LAN **18**, determine if they are directed to the Ethernet address of that peripheral, convert the payload data to a format useable by the peripheral, and to transfer the data to the process having the IP address in the packet.

[0090] Assuming that the service being carried by the home network requires bidirectional data transfer and ATM

is to be used upstream, the upstream data transmission process from the peripheral to the internet via the cable modem **12** is as follows assuming the cable modem is of the type defined in PCT publication WO 97/34421 which is incorporated by reference herein:

[0091] the application process that needs to send upstream data outputs one or more Ethernet packets onto the LAN **18** which include the IP address of the entity on the internet to which the data is directed;

[0092] each Ethernet packet gets routed through the gateway **14** to the cable modem **12** if it has an IP address which indicates it is directed to an entity on the internet to which the gateway is coupled through the cable modem **12**;

[0093] the SAR in the RU cable modem adds pad bits to each Ethernet packet, computes CRC-32 error detection bits, and adds RFC 1483 bits such that the resulting packet is an integer multiple of 48 bytes;

[0094] the SAR parses the packet into multiple 48-byte ATM cell payload sections with no header bytes, adds standard 5-byte ATM cell headers to each payload section using a virtual link identifier which identifies the virtual upstream channel assigned to that RU to construct the VPINCI fields and using last cell, normal cell and idle cell information to construct the PTI field and calculates a HEC field and transmits the resulting ATM cells to a formatter as a Utopia stream;

[0095] the formatter adds a 9th bit to each byte in the cell and encodes the 9th bits with a start code, last cell, normal cell and idle cell codes using the information in the PTI field of each ATM cell header;

[0096] the formatter strips off the 5-byte header of each ATM cell while saving the information and then parses each upstream ATM cell into 9-bit bytes and places one 9-bit byte into each timeslot of an upstream information vector which corresponds to the virtual channel assigned to this RU modem and transmits the information vector to the upstream transmitter in the RU cable modem **12** using the information in the VPI/VCI field of the header to identify which virtual channel in which each 9-bit byte from each ATM cell is to be transmitted;

[0097] the upstream transmitter of the RU modem transmits the upstream data in the appropriate virtual channel such as by spreading the spectrum of the 9-bit bytes using one or more spreading codes assigned to the virtual channel(s) assigned to the RU;

[0098] the spread spectrum data is then transmitted on the upstream carrier;

[0099] the receiver in the headend cable modem receives the upstream transmissions from each RU and demodulates, demultiplexes and detects the transmitted data of each 9-bit byte and places the recovered 9-bit bytes into the timeslots on a TDMA bus which correspond to the logical channel in which the data was received;

[0100] a formatter process in the headend modem demultiplexes the TDMA stream and reassembles

the 48-byte optimized upstream ATM cells using the signalling data in the 9th bits and places each ATM cell in a portion of a cell buffer dedicated to storing ATM cells from the RU which generated the data using the timeslot data to determine from which RU each ATM cell arrived;

[0101] a cell output controller process then retrieves each 48-byte ATM cell and generates a standard 5-byte header and transmits the standard 53-byte ATM cell in an OC3 format data stream to a segmentation and reassembly circuit in a router in the headend cable modem;

[0102] the SAR error checks the 53-byte ATM cell using the HEC field and strips off the header bytes while retaining the VPI/VCI and the PTI field information and reconstructs the AAL5 sequence using RFC 1483 bits and the last cell data encoded in the PTI field to find the packet boundaries and by concatenating 48-byte payload sections of the ATM cells and error checks the packet using CRC bits;

[0103] if no errors are found, the RFC 1483 bits and the CRC bits and pad bits are stripped off to leave an Ethernet packet header, an IP header and a payload section and the result is sent to a router for routing on the appropriate subnet to get to the destination having the IP address somewhere out on the wide area network.

[0104] If the cable modem **12** has the architecture of any of the cable modems described in Azzam, *High Speed Cable Modems*, suitable modifications to the above described downstream and upstream processes described above can be made, or the upstream and downstream processes used in those modems can be used for delivery of the same digital services they have used in the prior art to deliver. For example, any of the cable modem hardware and software structures known in the prior art which have been used in the actual field trials identified in Azzam, *High Speed Cable Modems*, Chapter 14, Section 14.2, pp. 512-518 (McGraw Hill 1997), ISBN 0-07-006417-2, may be used, and all of these modem designs are hereby incorporated by reference. The cable modems whose circuitry and software is incorporated by reference herein include: the LANcity Personal; Hybrid Networks Cable Client Modem 211; Zenith HomeWorks Elite; Motorola CyberSurfr; General Instruments SURFboard SB1000; Hewlett-Packard QuickBurst; Com21 ComPort; Toshiba and any cable modem that conforms to the IEEE 802.14 standard.

[0105] Typically, the IEEE 802.14 compliant cable modem genus will contain species which have the following characteristics:

[0106] downstream data contained in one of the 6-MHz TV channels that occupy the spectra above 550 MHz;

[0107] upstream channel assigned band between 5 and 45 MHz;

[0108] 64-QAM downstream modulation delivering over 30 Mbps data rate;

[0109] upstream channel using QPSK modulation or a combination TDMA and synchronous code divi-

sion multiple access multiplexing techniques and QAM modulation delivering from 2 to 10 Mbps in each upstream channel;

[0110] a media access control software layer to mediate upstream access between multiple users sharing the same cable medium;

[0111] a MAC protocol which is ATM friendly using the ATM cell transport concept and possibly involving segmentation of ATM cells into smaller segments to improve system performance;

[0112] status and control information looped back from the upstream to the downstream to provide remote cable modems with status and control information to determine pecking order;

[0113] the upstream channel divided into frequency channels that are allocated to individual users or combining two multiplexing methods such as TDMA and Synchronous CDMA or CDMA.

[0114] Cable modems within this genus include circuits and software to achieve time synchronization where frame alignment is necessary for proper demultiplexing. Although not required to be within the genus, the better modems in the genus also include time synchronization coupled with TDMA and CDMA to lower intersymbol interference as well as power alignment and adaptive equalization to minimize other forms of interference. These better modems will also include encryption such as pseudorandom scrambling or DES encryption for privacy and a MAC layer protocol that insures fairness in upstream bandwidth access.

[0115] These cable modems have been used to deliver residential online subscription services that include Internet access, Email, world news, shopping, local content covering city government, schools, libraries and other news of the community, multimedia services, campus networking, distance learning and telemedicine, internet access to schools, Prodigy, Jones Internet Channel and work at home programs.

[0116] Details of Gateway Interfaces To Downstream Cable, Satellite, And ADSL.

[0117] Referring to **FIG. 4**, there is shown a block diagram of one embodiment of gateway **14** configured as a standalone circuit where interfaces to the satellite, HFC and PSTN networks are all implemented on the circuit board. This circuitry may be an expansion card in a personal computer or it may be integrated into the motherboard of a personal computer. The other known components of the personal computer are not shown in **FIG. 4** for simplicity, but suffice it to say that the host CPU of the PC is coupled to circuitry shown in **FIG. 4** by the address, data and control buses of the PC such that the circuits that need control inputs or data from the host CPU may receive it. The control and data inputs needed by each circuit will be described when that circuit is described.

[0118] The embodiment of the gateway **14** shown in **FIG. 4** includes the entire circuitry of a DOCSIS1.2 cable modem **70** therein. Turning first to the interface circuitry to couple HFC to the LAN, HFC drop line **10** is coupled to an upstream and downstream combiner and isolation circuit **90**. There, upstream modulated RF carrier signals on line **92** from upstream isolation amplifier or coupler **94** are coupled

onto the cable **10** and downstream modulated RF signals are received from cable **10** and placed on line **96**. Typically, combiner **90** will include a bandpass filter to prevent upstream RF signals from entering line **96** and may optionally include a termination for line **92** to prevent reflections. Isolation circuit **98**, typically a buffer amplifier or capacitor or other circuitry such as a lightning arrester protects the internal circuitry of the gateway from any unwanted DC signals or lightning strikes on the HFC.

[0119] In the embodiment shown in **FIG. 4**, three tuners **100**, **102** and **104** are used. Tuner **100** is tuned to one of the conventional CATV analog video channels in NTSC, PAL or SECAM format. Typically, the total bandwidth of the HFC will be divided up into different frequency bands for CATV FDMA analog video channels, an upstream DOCSIS data and management and control signals band, a digital VOD signals band and a downstream DOCSIS data band. The frequency band for upstream data and management and control signals extends from 0 to about 50 MHz. Within this band, upstream DOCSIS data will be modulated onto one carrier frequency and management and control data will be modulated onto another carrier frequency. There may be multiple upstream management and control channels at different frequencies or in different timeslots or on the same frequency with the data of each management and control channel having its spectrum spread with a different spreading code. Typically, the frequency band from 50 to 500 MHz will be reserved for FDMA 6 MHz wide analog CATV video signals. Digital video data such as for VOD or teleconferencing etc. is typically modulated onto one of a plurality of different frequency channels in a band above 500 MHz with each channel being about 6 MHz wide and containing a plurality of video, audio and associated data subchannels separated by TDMA. Downstream DOCSIS data such as web pages which are downloaded during high speed internet access is typically modulated onto a carrier having a frequency somewhere above the video on demand carrier frequencies.

[0120] One of the functions of the gateway **14** is to deliver requested services to all the peripherals in the customer premises seamlessly over a shared LAN thereby eliminating the need for separate coaxial cable wiring to deliver CATV analog signals, a digital network to deliver digital data, telephone wires to deliver conventional telephone service. All these services are delivered via a single digital data distribution system comprised of one or more LANs. To that end, even CATV signals that are analog when they arrive are digitized, compressed, turned into IP packets and then into Ethernet packets and transmitted to the various televisions via a LAN.

[0121] Reception and Distribution of Analog CATV Signals

[0122] Tuner **100** starts this process by receiving control data from microprocessor **128** defining which CATV analog video channel which has been requested. Users request analog CATV broadcast channels via their IR keyboards **34** or remote controls **80** in **FIG. 3**. These requests are encapsulated into management and control Ethernet packets addressed to host CPU **128** by network adapter **30**. The host CPU receives them and generates a bus packet on bus **156** addressed to tuner **100** telling it which channel to tune. The host bus **156** may be a PCI bus in a Windows based personal

computer, but high traffic loads may bring such a bus to its knees since only two devices may use the bus to communicate at any particular time. In alternative embodiments, a high capacity multiplexed bus like an H.100 standard TDMA bus coupled by suitable bus drivers to the host bus in a computer with sufficient expansion slots for all the necessary expansion modules to implement a flexible gateway may be used. In other words, in smaller bandwidth consumption embodiments where only one or two of the expansion modules shown in **FIG. 8** are present, a Windows based personal computer with a PCI or ISA bus and one or two expansion slots may be sufficient. However, in higher bandwidth consumption embodiments where many or all of the expansion modules shown in **FIG. 8** are present or might be added as the number of services and external networks to be used grows, the gateway **14** may also take the configuration of one or more personal computers, each with a fast microprocessor and a PCI or some other fast bus, each running one or more of the software processes symbolized by **FIG. 8** to divide up the labor. These servers would be coupled to the LANs by one or more NICs with their one or more host buses coupled to another expansion module interface circuit board by one or more high capacity buses such as an H.100 TDMA bus, a Firewire or even FDDI or Fibre Channel Arbitrated Loop LAN technology. The expansion module interface circuit board would have a plurality of expansion slots interfaced to the high capacity bus(es) or LAN(s) coupling the expansion module interface circuit board to the one or more servers. Each expansion slot would be available to couple one of the expansion modules shown in **FIG. 8** to the shared software and hardware facilities of the servers. For simplicity of expression, all of these various alternative bus or LAN type interconnections between the server(s) and the modules in the expansion slots will be simply referred to as the host bus or the PCI bus **156**. There will also be descriptions of circuits to the effect of placing data in PCI bus or host bus packets addressed to a particular circuit to which they are to be sent such as the IP video circuit **158** or the routing process **86**. This is to be understood as actually placing the data into a packet with a destination address set to the destination circuit or process or seizing control of the host bus and writing the address of the destination circuit onto its control lines and placing the data to be transferred on the data lines and activating any necessary control signals to latch the address and strobe the data into a data register or other memory.

[0123] The RF output of tuner **100** on bus **134** is then digitized by an analog-to-digital converter in A/D matrix **130**. The digital samples on line **136** are input to a video demodulator **138** which functions in the digital domain to demodulate the digitized analog video signal by removing the RF component. The video demodulator **138** outputs digital data on line **166** which represents a conventional baseband NTSC, PAL or SECAM format video signal.

[0124] The digital data on line **166** is at too high a bit rate to send over the LAN since uncompressed broadcast video is at 221 Mbps. Therefore, the video data must be compressed. MPEG II compression is preferred, but any known form of compression currently known or to be developed in the future will suffice since the form of compression is not critical. MPEG II compression circuitry is well known, and is used for MPEG encoder **146**. However, MPEG compression does not compress NTSC, PAL or SECAM format signals. They must first be converted to YUV format lumi-

nance and chrominance signals. This conversion is done in video decoder **142**, which is a known type of circuit in any video system that uses MPEG II compression.

[0125] The compressed video data is encapsulated into PCI (or other type) bus packets addressed to IP video circuit **158**. There, the compressed video data is encapsulated into IP packets addressed to the network adapter of the TV where the CATV video channel is to be viewed. The IP video circuit **158** determines which IP destination address to use in constructing the IP packets via data received from the host microprocessor **128**. When the original request was received, the host microprocessor **128**, in addition to telling the tuner **100** which channel to tune, also determines from the Ethernet packet source address which TV's network adapter requested the data. The IP address of this network adapter is encapsulated into a PCI bus packet and transmitted via host bus **156** to the IP video circuit. The IP packets encapsulating the digitized CATV channel are then transmitted via bus **160** to the routing process **86**.

[0126] The routing process **86** is a conventional IP to Ethernet routing process which examines the IP packet destination addresses and looks up the corresponding Ethernet addresses. The IP packets are then encapsulated into Ethernet packets and routed to the appropriate LAN network interface card for LAN **18** or **20** depending upon the Ethernet destination address of each packet. The process works in reverse for incoming Ethernet packets from the LAN(s).

[0127] When the IP packets reach the network adapter of the TV that requested the CATV channel, they are converted to a video signal that can be displayed by the TV by the circuitry described below in conjunction with the discussion of **FIG. 5**.

[0128] Video on Demand

[0129] One disadvantage of watching CATV broadcast channels is that there is no facility to have VCR like controls such as pause, rewind, play, slow motion or stop over the incoming video. This is one reason why VOD is more advantageous. We turn now to an overview discussion of VOD delivered via cable modem. Later, VOD delivered by ADSL modem or satellite dish will be discussed. The discussions herein regarding delivery of VOD however apply equally to delivery of video conferencing services, home shopping, distance learning and other multimedia services involving video, images or other multimedia data. Also, there is great similarity in the functions and structure of the circuitry for receiving, recovering and distributing digital VOD via satellite so there will be some seeming replication of the discussions that follow. First, a quick overview.

[0130] The VOD downstream frequency band has multiple video channels, each at a different carrier frequency. Each video channel carries multiple TDMA channels of MPEG II compressed video with its associated audio, and sometimes with one or more additional TDMA subchannels devoted to associated data.

[0131] The tuner **102** is commanded by the host microprocessor **128** to tune to a particular VOD channel. The customer will order a particular VOD program using the IR keyboard **34** or remote control **80**. The microprocessor **128** receives the order information via management and control

Ethernet packets generated by the network adapter **30** and driven onto the LAN **20**. As an example of how the video, audio and associated data subchannels of a VOD program are used, suppose the tuner **102** is tuned to a home shopping VOD channel where a plurality of customers wish to buy an item being shown by the video data on a first subchannel and being described on the associated audio data subchannel, there may be multiple customers who wish to buy the item who need to talk to an operator. These multiple customers can have their telephone calls digitized into IP packets on digital telephones such as **62** in **FIG. 1** with each packet addressed to the IP address corresponding to the telephone number shown on the screen. These packets get encapsulated into Ethernet packets and transmitted on the LAN **18** or **20** to the gateway **14**. There, they are received by the switching process **86** and the Ethernet headers are stripped and the IP packets are sent to DOCSIS modem for transmission on an upstream channel.

[0132] At the headend modem, the IP telephony packets are recovered and routed to the IP address where the operators are standing by. Suppose, three callers are calling to buy the item being shown and described. The three different operators handling these calls have their speech digitized into IP packets addressed to the digital telephone being used by the caller they are talking to. These IP packets addressed to the telephones of the three different callers are QAM modulated by the headend modem modulator transmitting the VOD program and sent downstream as associated data on three different TDMA subchannels associated with the video and audio subchannels of the home shopping presentation.

[0133] The host microprocessor **128** tells tuner **102** which channel in the VOD band to tune to via control data transmitted via data, address and control bus **156** (also referred to as the host bus). The RF tuner **102** tunes to that channel and rejects all other signals.

[0134] The RF output of the tuner **102** is digitized by A/D matrix **130**.

[0135] Then the video, audio and associated values for each video, audio and data QAM modulated constellation point is recovered by the QAM demodulator **146**.

[0136] The recovered data values are then separated by transport demultiplexer **148** into video, audio and associated data streams on lines **150**, **152** and **154**. The transport demultiplexer receives control data from the host microprocessor via data, address and control bus **156** which tells it which subchannels to separate out in the demultiplexing process.

[0137] A conventional conditional access circuit **126** then decrypts the recovered data to prevent any unauthorized access thereto. The decryption process can be the same process used in current Ku band satellite digital video delivery or any other conventional encryption process. Since VOD subchannels are sent to only particular users, the data can be encrypted by PGP using the public key of the user to which the data is directed. That user then uses her private key to decrypt the data.

[0138] The conditional access circuit has a conventional PCI or other bus interface circuit. Typically the gateway is implemented as one or more circuit boards on a personal computer such as a Pentium class or PowerPC Macintosh

which has a system bus. Any system bus which is fast enough to carry the worst case system load bit rate will suffice. The worst case system load is based upon the number and type of peripherals in the house. Typically, a compressed digital video channel can be delivered with good picture quality at 2 Mbps, so if a household has 4 TVs all of which are tuned to a different VOD channel and one video conference going on, 10 Mbps should be adequate. PCI buses have maximum bit rates much above 10 Mbps so a PCI bus for system bus 156 is adequate for most applications. The conditional access circuit's bus interface packetizes the decrypted video, audio and associated data into PCI bus packets which are addressed to an IP video circuit 158 and placed on bus 156 via line 160.

[0139] The IP video circuit receives the PCI bus packets and encapsulates the video and audio data into IP packets addressed to the network adapter 30 which ordered the VOD program. The associated data is encapsulated into IP packets addressed to telephone 62 (or whatever telephone is being used to converse with the operator). The IP packets are then transmitted via line 160 to the routing process 86.

[0140] The routing process 86 is a conventional IP to Ethernet routing process which examines the IP packet destination addresses and looks up the corresponding Ethernet addresses. The IP packets are then encapsulated into Ethernet packets and routed to the appropriate LAN network interface card for LAN 18 or 20 depending upon the Ethernet destination address of each packet. The process works in reverse for incoming Ethernet packets from the LAN(s).

[0141] We now turn to a more detailed discussion of the process carried out by the system to receive VOD via either satellite, HFC or ADSL.

[0142] FIGS. 6A-6? together comprise a flowchart of the preferred embodiment of the processing which occurs in the system to order a VOD selection via either HFC, satellite or ADSL modem. Referring jointly to FIGS. 4A and 4B, 5 and 6A-6?, a user orders a particular video program via the IR keyboard 34 or remote control 80 acting as a pointing device to point to a displayed menu selection on TV 28 in FIG. 3. That selection is received by the IR or RF receiver 82 in FIG. 5, as symbolized by step 106 in FIG. 6A. The video selection along with the IP address of network adapter 30 is encapsulated in an IP packet and then encapsulated in an Ethernet packet by network adapter 30 and launched onto LAN 20 (step 108). The IP packet has the IP address of network adapter 30 as its source address and the IP address of the VOD server as its destination address. The IP address will usually be different depending upon whether the VOD selection has been ordered via HFC, satellite or ADSL since each network probably has its own video server. The user typically picks the VOD selection from a menu displayed on her screen for each network, so by pointing to the desired selection on the menu of the ADSL network, for example, the IP address is set to the IP address of the video server for the ADSL network.

[0143] The network adapter encapsulates the IP packet requesting the video selection in an Ethernet packet (step 108). The Ethernet packet destination address is the routing process 86 in the gateway. The IP packet payload message identifies the movie or other video program desired and, in some embodiments, identifies the particular VOD channel

and subchannel the gateway's VOD tuner will be tuned to (step 108). MPEG II compressed video is transmitted on two or more subchannels (one video, one associated data and zero or more associated video subchannels), and this is done regardless of whether the delivery media is HFC, satellite or ADSL. Step 108 represents the preferred process wherein the headend of the HFC, satellite network or ADSL central office monitors the channels and subchannels for load and sends downstream load balancing messages indicating which channels and subchannels are free. These load balancing messages are monitored by the gateways, and the channels and subchannels that are available are selected by the gateways for "camping" thereby helping balance the load across the network. In other embodiments however, the video server and/or headend may simply put the requested video selection on any unused subchannels of a channel that is not fully occupied and sends a downstream management and control message to the gateway from which the request originated indicating where the requested video selection will be found. The host microprocessor 128 in the gateway then sends data to its circuitry to cause the right channel to be tuned and the right subchannels to be demultiplexed. The "subchannel" means the particular timeslots or spreading codes to use in receiving the video data when tuned to the frequency of the "channel". In embodiments where only one video subchannel per channel is carried, then subchannel and channel mean the same thing.

[0144] In the preferred embodiment, the headend modem (or other headend circuitry such as the uplink transmitting center in the case of satellite or the ADSL central office—hereafter these other headend circuits will be referred to as headend modems for brevity) has a plurality of VOD modulators/transmitters (hereafter called modulators), each of which is coupled to the VOD server and each of which receives a plurality of streams of MPEG II compressed video data. Each modulator is structured to transmit one VOD channel downstream with the plurality of MPEG II compressed video/audio/associated data streams being multiplexed therein by TDMA, CDMA or Synchronous CDMA.

[0145] To implement the preferred form of load balancing, the headend modem keeps track of which subchannels of each downstream VOD channel are in use. It then broadcasts management and control messages to all gateways via the HFC, satellite downlink or ADSL lines of subscribers indicating which VOD channels and subchannels are available and which upstream channels the gateways are to use in sending messages that indicate that a gateway has "camped" on a particular channel and subchannel.

[0146] The meaning of the term "camped" or "camping" is as follows. The gateways receive these broadcast load balancing messages and the host CPU of each gateway with a pending VOD request commands their VOD tuners (such as tuners 102 or 180 or a corresponding tuner in ADSL modem 182 in FIG. 4A) to tune to a channel that has an available subchannel, as symbolized by step 108. The host CPU then commands the appropriate transport demultiplexer (e.g., demultiplexer 114 for HFC delivery or demultiplexer 184 in the case of satellite or a similar but not shown demultiplexer in the ADSL modem 182) to demultiplex and select out only the compressed video and audio data subchannels carrying the requested program as well as the associated data subchannels. "Camped" or "Camping" therefore means tuning of the appropriate digital VOD

tuners and transport demultiplexers in the gateway to a particular channel and subchannel.

[0147] The channel and subchannel camping information is included by the gateway in the IP packet bearing the upstream video request, or is included within a separate IP packet generated by the gateway that refers to the IP packet bearing the VOD request, also as symbolized by step 108. This camping data aids the video server or router in the headend modem (or the corresponding circuitry in a satellite or ADSL VOD network) to get the requested video data to the correct modulator which is transmitting on the VOD channel to which the gateway coupled to the requesting IP address is tuned. The channel and subchannel data included in the upstream message is also used to control that modulator to put the video and associated audio data on the subchannel to which the gateway is tuned.

[0148] Continuing with the discussion of FIG. 6A, the Ethernet packet is received by switching process 86 (after it passes through the network adapter card of the host computer and up through the Ethernet protocol layers where the Ethernet header is stripped off as symbolized by step 110). The switching process looks up the destination address of the IP packet in a lookup table and determines from the destination address of the IP packet that it is directed to a VOD server coupled to the headend modem driving HFC 10 or the headend circuitry driving the uplink to the satellite or to the ADSL central office (step 112).

[0149] Step 116 represents the general process of transmitting the IP packet containing the VOD program request to the appropriate video server over the appropriate transmission media. The following paragraphs discuss the various cases individually, and step 116 is to be interpreted as covering each of these individual cases depending upon which video server is addressed by the IP packet. The following discussion assumes the gateway is equipped with HFC, satellite and ADSL expansion modules so that VOD can be ordered from any of these three networks. The gateway however may have only some subcombination of one or more of the HFC, satellite or ADSL modem expansion cards, so step 116 will only represent routing the IP request packet to one video server or possibly a selected one of two different video servers delivering VOD over two different networks.

[0150] In the case of an IP request packet addressed to a video server coupled to the HFC 10 via the headend modem for delivery of a VOD selection via the HFC, step 116 represents the following subprocess. The IP packet gets routed to DOCSIS modem 70 and transmitted on an upstream management and control channel. In the preferred embodiment, the management and control channel used to transmit the upstream request is the channel designated in a downstream load balancing message from the headend modem indicating which channels and subchannels are available and which upstream channels the gateways are to use in indicating they have camped on one of the available channels and subchannels. The IP packet is recovered from the HFC and coupled directly or via the internet to the video server to which it is addressed. The video server may be coupled directly to headend modem or indirectly via the internet in which case the IP request packet is sent by a router at the headend over the internet to the video server.

[0151] In the case of an IP request packet addressed to a video server coupled to the satellite uplink headend circuitry,

the upstream channel is over the PSTN so step 116 represents the following. The IP packet get routed to the ADSL modem 182 or the DOCSIS modem 70 for upstream transmission over the phone lines. If routed to the ADSL modem, it transmits the IP packet request message upstream over the PSTN lines to the ADSL central office where it gets routed to the video server coupled to the satellite uplink over a connection to the internet at the CO or a dial-up connection over the PSTN to the video server directly.

[0152] If the IP packet addressed to a video server that delivers VOD over the satellite network is routed to the DOCSIS modem, the IP packet gets transmitted over the HFC to the headend DOCSIS modem. There, the packet gets recovered and reassembled (if necessary) and sent to a router for delivery over the internet or other WAN to the video server to which the packet is addressed. Alternatively, the headend DOCSIS modem may make a dial up connection over the PSTN to the video server or use IP telephony to deliver the packet to the video server over the internet via IP telephony circuitry coupled to the internet at the video server.

[0153] If the IP VOD request packet is addressed to a video server that delivers via ADSL, step 116 represents the following. Routing process 86 routs the IP packet to the ADSL modem 182 where it is transmitted via the ADSL upstream channel to the ADSL modem at the CO. The CO then routes the IP VOD request packet to a video server directly coupled to the CO or gives it to a router connected to the internet for routing to a video server coupled to the CO via the internet (the term internet means the internet or any other wide area network currently in existence or which may come into existence in the future). Alternatively, the CO may make a dial up connection to the video server over the PSTN and send the IP VOD request packet over the dial up connection or may communicate with another CO where a video server is located by a T1 line or DS1 or other high speed telephone lines. The processing and circuitry for ADSL delivery of video demand taught in U.S. Pat. No. 5,247,347 may be used, and that patent is hereby incorporated by reference.

[0154] Step 120 represents the optional step of authentication and/or conditional access gating carried out at the headend prior to routing the IP request packet to the video server. In some embodiments, the IP packet bearing the VOD request is routed to the video server only if the user making the request is authenticated and/or is an authorized subscriber to the requested service. This is typically by using the source address as a search key to search a lookup table of authorized users. The manner in which the requested services such as VOD are monitored so that they are delivered only to authorized subscribers is not critical to the invention, and the lookup function mentioned as part of step 120 can be replaced with any known manner of gating services only to authorized users. The gating function can also be done at the gateways after transmission of the VOD data downstream, and the gateway 14 shows conditional access modules 126 and 186 representing these embodiments. In these embodiments where the conditional access gating function is performed at the gateway, step 120 is not needed. Processes for performing conditional access gating at the customer premises are well known in C band and Ku band subscription-based analog and digital video broadcasting, and need not be detailed here. To implement this known

type of conditional access at the consumer premises, each gateway has a decryption module (126, 186 and similar circuitry in ADSL modem 182) with a key or password stored therein. This key or password is used by the video server or other service provider to encrypt the VOD data or other data encoding the requested service using the authorized subscriber's public key. Only that subscriber can decrypt the data using his private key. The conditional access modules 126 and 186 in FIG. 4A are intended to symbolize any of these known prior art structures and processes for blocking access by unauthorized persons to services.

[0155] After the IP packet reaches the video server, it reads the IP packet and opens the file storing the data of the requested movie or other video production (step 124). The video server then begins transmitting the video data as IP packets addressed to the TV and network adapter 30 that requested the movie (step 124). The IP packets contain compressed video data, typically by MPEG II compression. Step 124 is intended to represent one of the following three subprocesses of delivery of the video data bearing IP packets depending upon the video server to which the original IP packet bearing the VOD request was directed and whether the IP video data packets are to be delivered over HFC, via satellite or via a DSL connection. Step 124 is not intended to represent delivery of the VOD data by all three networks. The discussion of each subprocess is labeled by a header, and three different lines of steps are shown in FIGS. 6A-6C for the three different delivery networks since each delivery network is coupled to different circuitry in the gateway 14.

[0156] First, in the case of HFC delivery, step 124 represents the process of transmitting the IP VOD packets to the modulator in the headend modem which is transmitting downstream on the channel identified in the original request packet. Transmission to this modulator can be by a local direct connection, or via the internet or other WAN or by a T1 or DS1 leased line or possibly by other high speed PSTN connection such as DSL.

[0157] The video data is compressed in any known manner and is encrypted before transmission. The preferred manner of implementing conditional access is to do the gating function at the video server end of the connection to avoid wasting downstream bandwidth on requests by unauthorized users.

[0158] In the HFC delivery case, the compressed video and audio data (and possibly associated data such as IP telephony packets) is transmitted by the headend on the channel and subchannels identified in the camping data given in the original request message and arrives at the gateway 14 via line 10 (step 136). In alternative embodiments, the video server and headend will cooperate to put the VOD data on unused subchannels of a channel that is not fully utilized and send a downstream management and control message telling the gateway where to find the VOD program it requested (step 136).

[0159] Upon reaching the gateway on the HFC connection 10, the RF downstream signal is coupled through coupler 90 to buffer/isolation circuit 98 and reaches tuners 100, 102 and 104. Tuners 100 and 104 reject it because they have been instructed by the host CPU 128 of the gateway to listen on the analog video and DOCSIS data carrier frequencies, respectively. Tuner 102 however has been instructed by host

microprocessor 128 (hereafter, the "host") to tune to the channel on which the VOD data is modulated. In tuner 102, the RF signal is received the RF component is removed and, a baseband signal is output on line 190. In some embodiments, the tuner 102 outputs an IF signal on line 190 which is digitized in A/D matrix 130 with the IF mixed down to baseband by QAM demodulator 146 prior to demodulation of the constellation points. Also, in some embodiments, conventional carrier recovery and clock recovery is performed in tuner 102, and the RF component is removed using a local carrier synchronized in frequency and phase with the transmitter's carriers to reduce the RF signal to I and Q baseband signals on lines 190 and 191.

[0160] The VOD data bearing RF carrier is QAM modulated, so the tuner outputs a complex analog baseband signal on line 190 with an inphase and a quadrature component, each having multiple sample periods each of which defines the I and Q values for one constellation point. Both components are sent to A/D matrix 130 for sampling with one sample per constellation point on each of the I and Q signals.

[0161] The A/D matrix is comprised of either two or three A/D converters depending upon whether the DOCSIS modem 70 has A/D conversion circuitry therein. Typically, it does, so the output of the DOCSIS data tuner 104 on line 132 is shown as passing the baseband signal straight through the matrix 130 without any sampling thereby.

[0162] The samples of the baseband analog I and Q signals on lines 190 and 191 containing VOD data constellation points are output on bus 136. The process of receiving the RF downstream VOD signal and demodulating and digitizing each constellation point's I and Q values is symbolized by step 136. In the preferred embodiment, the clock signal embedded in the data (or transmitted on a separate channel in some embodiments) defining the boundaries of each constellation point is recovered by tuner 100 and is made available to any of the other circuits that need it to deal with the video data.

[0163] The digitized, compressed VOD data is typically QAM-64 modulated. This means that the video and audio data is transmitted in the form of constellation points each point transmitted during a different time on the quadrature carriers with video, audio and associated data constellation points transmitted during different timeslots on the same channel. Each video, audio or associated data point takes the form of a complex number having a phase and an amplitude value. QAM demodulator 146 determines the complex value of video, audio and corresponding data points of the compressed VOD data that correspond to each constellation point (step 140).

[0164] Transport demultiplexer 148 functions to demultiplex the video, audio and associated data points from their respective subchannel timeslots (or codes in embodiments where the subchannels are CDMA multiplexed) as symbolized by step 144. The video demultiplexer receives a control data input from the microprocessor 128 that tells the demultiplexer which subchannel timeslots (or codes) to use in retrieving the requested VOD data.

[0165] The retrieved video, audio and associated data is output in compressed form on buses 150, 152 and 154 to a conditional access circuit 126. This optional circuit descrambles the data if the user is authorized to receive the

program ordered or does other known types of conditional access gating if the conditional access function has not already been done at the headend (step 192). If the user is authorized to receive the VOD data, the video, audio and associated data points are encapsulated into bus packets used on the host bus 156 and sent over the bus to an IP video encapsulation process 158. Typically, the host bus is a PCI bus so known PCI bus interface circuits in conditional access circuit 126 encapsulate the VOD data into PCI bus packets addressed to the IP video encapsulation circuitry (step 192).

[0166] The IP video circuitry monitors the bus 158 for packets addressed to it and when it finds one, it takes the PCI bus packets that together comprise an IP packet of VOD data and reassembles the VOD data therein into an IP packet payload. In cases where the VOD data was never put into an IP packet format at the headend, the VOD video and audio data are assembled into IP packets addressed to the network adapter that requested the VOD program. Any associated data is encapsulated into an IP packet addressed to the appropriate peripheral such as the PC 22 or the telephone 60 in FIG. 3. Usually, the IP destination address to which the video, audio and associated data are bound is included within the data itself, and if an IP packet was broken up into, for example octets or ATM cells for transmission, the original IP source and destination addresses are preserved such as by the methods described previously herein.

[0167] In the preferred embodiment, the IP source and destination addresses in the IP packet data within the PCI bus packets are used to assemble an IP packet header upon reassembly of the IP packet. The resulting IP packets are transmitted over line 160 to the routing process 86 (step 194). In embodiments where the VOD video, audio and associated data was never placed into an IP packet format, the host 128 keeps track of where each VOD request came from on the LAN and the addresses of the video server to which each is addressed. The when data arrives from that video server (as determined by the source address of the data or the network, channel and subchannel on which the data arrived), the host sends data to the IP video circuit 158 telling it the IP address of the network adapter the video and audio data are to be addressed to and the IP address of any other peripheral to which any associated data is to be sent. The case where the VOD data is not originally encapsulated into an IP packet could happen where a video server is coupled directly to a headend modem or a satellite uplink facility or an ADSL CO. Step 194 is to be also interpreted as covering this alternative case of constructing IP packets using IP addresses supplied from the host 128 which is monitoring all outgoing VOD requests.

[0168] The routing process 86 receives the VOD IP packets and reads the IP destination address and determines that the IP address is mapped to the Ethernet address of network adapter 30 in FIG. 3. The IP packets addressed to this network adapter are then encapsulated into Ethernet packets addressed to the network adapter 30 and sent to the appropriate network interface circuit in routing circuitry 86 for launching onto LAN 20 (step 196). The household might have multiple TV sets, each with its own network adapter. In such a case, the IP destination address in the VOD data will be used to determine which network adapter ordered the program and that network adapter's Ethernet address will be used in the Ethernet packet headers of the Ethernet packets

into which the VOD data IP packets are encapsulated. The routing circuitry will then determine which LAN and NIC to use to get the data to the right TV.

[0169] What happens to the VOD data when it gets to the network adapter will be discussed below after the discussion of the ADSL and satellite delivery cases.

[0170] DSL Network Delivery

[0171] In the case of ADSL delivery (or delivery by any digital subscriber line service with adequate bandwidth), the IP packets are transmitted from the video server to an ADSL central office within approximately 3 miles of the subscriber by a T1 or DS1 line typically although an ADSL downstream connection might be used if the possible maximum load of VOD data being sent to this particular CO is light enough (step 198, FIG. 6B).

[0172] From the ADSL central office, the video data IP packets are FDMA multiplexed onto the ADSL downstream carrier and transmitted to the gateway of the requesting subscriber via the appropriate local loop. At the gateway, the IP packets arrive on the PSTN local loop 58 and coupled through an isolation buffer 204 to the ADSL modem 182 (step 202).

[0173] The ADSL modem 182 is a conventional structure and recovers the IP packets in conventional manner and outputs them on line 188 to the switching process. There, the IP packets bearing VOD data are encapsulated in Ethernet packets addressed to the NIC of network adapter 30 which ordered the video program and sent to the appropriate NIC in routing circuitry 86 which interfaces to the LAN to which the network adapter 30 which ordered the VOD program is coupled (step 206).

[0174] In embodiments where only a single LAN is in use at the customer premises, an ADSL modem 200 (shown in dashed lines to indicate it is an alternative embodiment) with an Ethernet output interface may be substituted for ADSL modem 182 with the ADSL modem output coupled directly to the LAN.

[0175] Satellite Network Delivery

[0176] In the case of satellite delivery of the video data IP packets, the video server for the satellite network delivers the VOD data IP packets to the satellite uplink facility by any suitable means such as a T1 or DS1 leased line or by direct connection to the uplink transmitter if the video server is located at the uplink facility (step 208).

[0177] The uplink facility modulates the IP packet data onto the DirecPC uplink carrier or another carrier devoted to VOD applications and transmits it to a geosynchronous satellite (step 210).

[0178] A transponder on the satellite then recovers the IP packets and QPSK modulates them (or using some other suitable modulation scheme) onto a DirecPC or VOD downlink carrier and transmits them to all the dishes in its footprint area on the surface of the earth (step 212).

[0179] Tuner 180 (FIG. 4A) receives the RF signal and does conventional carrier and clock recovery so that the recovered carrier and clock signals can be used in demodulating, detecting and demultiplexing the signals as was the case for the preferred embodiment of tuner 102. Tuner 180 receives data from host 128 via host bus 156 that tells it

which downstream channel to which it should tune, and it tunes out all other RF signals. The VOD downlink quadrature carriers are then demodulated and I and Q baseband signals are output on lines **216** and **218** (step **214**).

[**0180**] Analog to digital conversion can happen anywhere after the tuner **180** and prior to the IP packetization circuit **158**. However, for parallelism with the HFC case, we will assume that A/D conversion happens in the QPSK demodulator **220** prior to the constellation point demodulation process. The recovered clock from the tuner **180** is used to synchronize the demodulation and A/D conversion processes in circuit **220**. The I and Q values of the QPSK constellation points are then demodulated to their original analog or digital values to yield a stream of video, audio and associated data points on bus **222** (step **224**). If they are demodulated to analog values, these analog values for the I and Q values of each constellation point are later digitized.

[**0181**] The satellite VOD delivery system is much like the HFC system in that video programs are delivered on channels each having a different downlink frequency and each having a plurality of TDMA or CDMA subchannels. It is the function of transport demultiplexer **184** to receive data from host **128** telling it which subchannels to recover and to demultiplex the video, audio and associated data points from their respective subchannels (step **226**). The transport demultiplexer **184** has any conventional TDMA or CDMA demultiplexing structure that can receive data indicating which subchannels to recover and recover them and can be the same structure as transport demultiplexer **148**.

[**0182**] The recovered video, audio and any associated data are output to a conditional access circuit **186** via buses **228**, **230** and **232**. The optional conditional access circuit **186** functions to decrypt or otherwise gate the VOD data to the subscriber who requested it only if she is a legitimate subscriber and if this gating function was not performed at the satellite uplink facility or the video server (step **234**). The conditional access circuit can have any of the known structures to perform this function.

[**0183**] The conditional access circuit has a host bus interface circuit (not separately shown) which functions to take the data from the VOD IP packets (usually the IP packets bearing VOD data are broken up for transmission over the channel) and encapsulate the data into bus packets of the type used on the host bus **156**, e.g., PCI bus packets. These packets are addressed to the IP video circuit **158** (step **236**).

[**0184**] The IP video circuit functions as previously described. Basically, it takes packet addressed to it off the host bus **156** and either reassembles the IP packet if it was originally an IP packet but was broken up for transmission (such as into ATM cells) or encapsulates the data into an IP packet if it never was in an IP packet format (step **238**). Presumably, the incoming VOD data includes the IP destination address in it. However, in some embodiments, the host **128** will tell the IP video circuit **158**, "If you receive data from conditional access circuit **186**, it is to be addressed to the IP address of network adapter xx which requested it." One way or another, the IP video circuit **158** assembles an IP packet header for each packet that tells the routing circuitry **86** where the packet is to be sent on the LAN. The resulting IP packets are sent to the routing circuit **86** via bus **160** (step **238**).

[**0185**] The routing circuit **86** looks up the Ethernet address bound to the IP address, encapsulates each IP packet

into an Ethernet packet and routes it to the appropriate network interface circuitry in router **86** for the LAN to which the network adapter is coupled which ordered the VOD program (step **240**).

[**0186**] Note that if there is associated data with the VOD program which needs to go to the personal computer **22** or to IP telephone **60** in **FIG. 3**, that data has its IP address set to the PC or the telephone as the case may be and the router **86** addresses the Ethernet packets containing this associated data to the Ethernet address of the PC or telephone or other peripheral as the case may be and this is true regardless of whether the VOD data is delivered by ADSL, HFC or satellite (steps **238** and **194**).

[**0187**] The Network Adapter Structure and Subprocess for Video on Demand Processing

[**0188**] Regardless of which network was used to transmit the VOD program, the data that encodes the program has now been encapsulated into Ethernet packets and put onto the LAN. A block diagram of a typical network adapter **30** in **FIG. 3** is shown in **FIG. 5**. The function of the network adapter is to pick the appropriate Ethernet packets off the LAN, strip out the video and audio data and convert it to an NTSC or PAL or SECAM signal or to a video signal which can be fed into a video input of a TV.

[**0189**] Each network adapter has a network interface card **84** which couples the network adapter to the physical media of the LAN. Network interface circuits for Ethernets are well known, and will not be described further herein. Each NIC on the LANs **18** and **20** has a unique Ethernet address which maps to one or more IP addresses. Thus, when an IP packet addressed to the IP address of network adapter **30** arrives at the gateway, the gateway's routing tables will map this IP address to the Ethernet address of the network adapter. The entire IP packet, header and all, will then be encapsulated into an Ethernet packet with the destination address of the Ethernet packet being that of the network adapter.

[**0190**] All Ethernet packets are received by NIC **84**, but only packets addressed to the network adapter **30** are kept. When an Ethernet packet addressed to network adapter **30** is received, it is examined to determine if the Ethernet address matches the address of the network adapter, and, if so, the packet is passed through the Ethernet protocol stack where the Ethernet header is stripped off and error detection and correction are done on the packet. The resulting IP packet is then passed to the IP video circuit **242** (step **244**). For outbound packets such as menu requests and VOD request packets, the Ethernet protocol stack in NIC **84** performs the CSMA/CD transmission and collision detection protocol and transmits the packet on the LAN.

[**0191**] The IP packets from the NIC **84** are examined by the IP video circuit **242** to determine if they are addressed to the network adapter and whether they are graphics data or video data. The IP packet header is stripped off and payloads of packets that contain compressed video/audio data are transmitted as a bit stream to MPEG decoder **246**, and packets that contain graphics data are transmitted as a bit stream to 2/3 D graphics circuit **83** (step **248**). In some embodiments, the menus will not be sent as separate data but will simply be video frames which are digitized and compressed. In such embodiments, bus **87** is not necessary.

[**0192**] The MPEG decoder **246** decompresses the compressed video and audio data bits and generates and uncom-

pressed audio bit stream on line **250** and an uncompressed video bit stream on line **252** (step **258**).

[**0193**] The audio bit stream is enhanced for stereo and filtered and then converted to an analog signal in any conventional audio processor **254** (step **258**). In alternative embodiments, the uncompressed audio data not processed to enhance it or convert it to stereo or filter it and is simply converted to an audio signal.

[**0194**] The data output on line **252** is a digitized YUV format video signal. Video processor **256** filters the video signal to enhance it (step **258**). The combination of the video processor **256** and the 2/3 D Graphics circuit **83** are commercially available in integrated circuit form from ATI or C³.

[**0195**] The digitized YUV format video signal on line **264** (or **252** if video processor **256** is not used, is converted by video encoder **260** into an NTSC, PAL, SECAM or composite format video signal which can be displayed on a TV (step **262**). If the output signal format is composite video, the composite video signal is input to the TV's video inputs via line **266** (step **262**). Likewise, the audio processor converts the digitized uncompressed audio data into an audio signal on line **270** for coupling into the audio input of a TV (step **272**). If the output signal from the video encoder **260** is NTSC, PAL or SECAM format, the signal is modulated onto an RF carrier at some locally unused frequency such as channel 3 by a video modulator **276** (step **274**).

[**0196**] Wideband Internet Access

[**0197**] Dial up internet connections through modems are very slow. It is much more useful to surf the internet with a much wider bandwidth at least downstream.

[**0198**] Referring to FIGS. 7A-7?, there is shown a flow-chart of the process of high bandwidth surfing of the internet using one of the HFC, satellite delivered DirectPC or DSL networks. In step **278**, the personal computer **22** in FIG. 3 or network computer (hereafter sometimes referred to as NC) **24** or **26** launches its browser and enters a URL of a web page to be viewed. The network computers **24** and **26** do not have any local hard drives, so they execute their browsers from the hard disk of the personal computer via known techniques of executing shared software on a server over the network or over a WAN such as the internet. Typically, the network computers indicate which program they want to run by double clicking an icon on their desktops. This action is converted to a request to download the program from a server on the LAN or WAN into the RAM of the network computer. This request is converted by the NIC of the network computer into an Ethernet packet directed to the server on the LAN. The server NIC picks up the packet, opens the file, and generates one or more Ethernet packets directed to the network computer which receives the packets and loads the browser program or other application that needs internet access into RAM and begins executing it.

[**0199**] If the program to be run is resident on a server on the internet, the step of double clicking the icon of the program to be run is converted by TCP/IP protocol software layers in the network computer (typically stored in nonvolatile flash EEPROM or ROM) into an IP packet addressed to the server storing the application program to be run. The IP packet is then encapsulated into an Ethernet packet by the NIC of the NC addressed to the gateway **14**. At the gateway,

the Ethernet packet is received by the NIC and the Ethernet headers are stripped off by the routing process **86**. The packet is then routed to the appropriate transmitter for the upstream medium the user has a subscription for or which is cheapest for internet access if the user has DSL, satellite and HFC modules installed—or some combination thereof (least cost routing process). In other words, the IP packet will be routed to the DOCSIS modem **70** for upstream transmission over the HFC **10** or to the ADSL modem **182** if the DSL service or to conventional modem **280** (which may also be a conventional FAX/Data modem) if satellite downloading service via DirectPC is to be used. The IP packet is sent by one of these media to the headend, ADSL CO or by dialup connection to the satellite uplink facility. At the destination, the IP packet is recovered and routed by a router at the destination to the internet server storing the application to be executed.

[**0200**] The internet server then sends the program to be executed to the network computer by encapsulating the data of the program into IP packets addressed to the NC that requested it. These IP packets arrive at the gateway and are recovered by the DOCSIS modem, ADSL modem or satellite reception circuitry to be described below and sent to the routing process **86**. There, they are encapsulated into Ethernet packets addressed to the NIC of the NC that requested the program and launched on the LAN. The NC receives the packets, strips out the data of the program, stores in its RAM and begins executing it.

[**0201**] The user then enters the URL of the web site she wants to visit (step **278**). The browser or other application then passes this URL down to TCP/IP protocol software processes in execution on the computer which turn the URL into an IP packet requesting that the web page at that URL be downloaded to the computer that asked for it, as identified by the source address of the IP packet (step **282**). This IP packet is then encapsulated into an Ethernet packet addressed to the gateway **14** by the NIC of the NC or PC (step **284**).

[**0202**] The gateway's NIC (not shown separately in FIG. 4A) receives the Ethernet packet, strips off the Ethernet header after error detection and correction and passes the IP packet up to the routing process layers. The router looks up the destination address in its routing tables and forwards the packet to one of the upstream transmitters (step **286**). If the user has only one network interface such as an HFC interface only or an ADSL interface only installed (as determined by either a discovery process carried out by the router or by configuration data), the IP packet is forwarded to that upstream transmitter. However, if user has more than one network interface installed, the router may forward the IP packet to an upstream transmitter based upon any criteria such as user choice as indicated by a management and control packet sent to the gateway or a field in the IP packet, by a random or round robin selection process or by a least cost routing algorithm that automatically picks the cheapest service for widebandwidth internet access. Step **286** is intended to represent any of these methods of selecting the upstream transmitter.

[**0203**] If the upstream transmitter is the DOCSIS modem **70**, the IP packet is transmitted upstream over a virtual channel devoted to this gateway or assigned to it on the fly by the headend. The virtual channel can be established by

TDMA, SCDMA or CDMA or possibly by FDMA. The CO modem recovers the IP packet and passes it to a router coupled to the headend (step 288).

[0204] If the upstream transmitter is the ADSL modem 182, the IP packet is modulated onto the upstream carrier and transmitted over the PSTN local loop 58 to the ADSL modem at the CO. There, it is recovered and passed to a router coupled to the internet (step 288).

[0205] If the downstream medium is going to be the satellite downlink, the upstream transmitter is the conventional modem 280. This modem dials a modem at the satellite uplink facility and transmits the IP packet thereto. The IP packet is recovered and passed to a router coupled to the internet (step 288).

[0206] The router sends the IP packet to the web server at the URL (step 290) which opens the web page identified in the URL and begins sending the web page data back to the router as a series of IP packets (step 292).

[0207] The IP packets arrive at the router and are sent to the appropriate downstream transmitter. Step 294 is intended to represent downstream transmission over any of the HFC, DSL or satellite media. In the case of HFC delivery, the downstream transmitter will be the headend modem. The headend modem will either broadcast the IP packet on the downstream carrier to all gateways or transmit it on a virtual downstream channel assigned to the gateway at the premises of the PC or NC that requested the web page (step 294).

[0208] If the downstream media is the satellite downlink, the router sends the IP packets to the uplink transmitter which transmits them to the satellite. A transponder on the satellite receives the packets and re-broadcasts them on the downlink channel (step 294).

[0209] If the downstream media is a DSL local loop, the router at the CO sends the IP packets to the ADSL modem at the CO which modulates them onto the downstream carrier (step 294)

[0210] Step 296 is represents the recovery of the IP packets at the gateway, regardless of the downstream media, transmission to the router, protocol conversion and routing and transmission out on the appropriate LAN. The details of how this happens in the gateway for each different downstream media follows.

[0211] In the case of HFC downstream delivery, tuner 104 filters out all but the DOCSIS downstream carrier and removes the RF component. The resulting baseband signal is passed through the A/D matrix on line 132 to the DOCSIS modem 70. There, the IP packets are recovered and sent to the routing circuit 86 via bus 300. Although this is shown as a separate bus, it may actually be the host bus 156 in some embodiments with the IP packets being sent to host micro-processor 128 by encapsulation in PCI bus packets addressed to the host. Likewise for all other buses shown in FIG. 4A going into or coming out of the routing circuit 86. The router 86 looks up the destination address in the IP packets and determines they are addressed to PC 22 or one of NC 24 or 26. The router then encapsulates the IP packets into Ethernet packets addressed to the appropriate PC or NC and directs them to the NIC for the proper LAN connected to the PC or NC that requested the data (step 296).

[0212] In the case of satellite downstream delivery, tuner 302 in FIG. 4B is directed by host 128 to tune to the DirectPC downstream QPSK modulated carrier. The tuner rejects all other signals and recovers the carrier and synchronizes a local oscillator to generate two coherent reference signals which are phase and frequency matched to the two quadrature carriers used to transmit the downstream IP packets. These local reference signals supply two correlators in the tuner, one for the inphase channel and one for the quadrature channel. Each correlator is comprised of a multiplier and an integrator. Digital QPSK transmission and transmitters and receivers therefore as well as other modulation and multiplexing schemes and carrier and clock recovery circuits are described in Haykin, *Communication Systems, 3rd Ed.* (Wiley & Sons 1994) ISBN 0-471-57178-8 which is hereby incorporated by reference. The digital satellite receiver channel is not limited to QPSK modulation, and any modulation and/or multiplexing scheme used today or subsequently for downstream transmissions may be used with suitable adjustments to the gateway satellite digital data receiver.

[0213] The output of receiver 302 is coupled via I and Q buses 306 and 310 to a QPSK demodulator 304 which functions to recover the IP packet data and encapsulate it into bus packets for the host bus addressed to the routing circuit 86. The QPSK demodulator 304 is typically comprised of a decision device that receives the baseband I and Q channel signals and compares them to decision threshold of zero volts. If the I channel voltage is greater than zero, a decision of logic 1 is made but if its voltage is less than zero, a decision of logic 0 is made. If the Q channel voltage is greater than zero, a decision of logic 1 is made but if its voltage is less than zero, a decision of logic 0 is made. Finally, the two binary bit sequences defining the IP packets coming out of the decision circuit are recombined in a multiplexer in demodulator 304 and sent to bus interface circuitry in demodulator 304 for encapsulation into bus packets and transmission via bus 312 and the host bus 156 to the router 86. The router receives them, strips off the host bus packet headers, looks up the IP destination address and finds they are addressed to the PC 22 or one of the NCs. The IP packets are then encapsulated into Ethernet packets (or whatever other packet format is used on the LANs 18 or 20) addressed to the PC or NC that ordered the data and sent to the proper NIC (step 296).

[0214] If the downstream media is an ADSL local loop, a conventional ADSL modem 182 in FIG. 4A recovers the IP packets and sends them on bus 188 to the router 86. The router receives them, strips off the host bus packet headers (if bus 188 is actually the host bus 156), looks up the IP destination address and finds they are addressed to the PC 22 or one of the NCs. The IP packets are then encapsulated into Ethernet packets (or whatever other packet format is used on the LANs 18 or 20) addressed to the PC or NC that ordered the data and sent to the proper NIC (step 296).

[0215] The NIC of the PC or NC that ordered the data receives the Ethernet packets, does error correction and strips off the Ethernet headers. The resulting IP packets are passed up the TCP/IP protocol layers where the IP packet headers are stripped off and the TCP protocol makes sure all the packets have been received. The payload data is then sent to the application that requested it for display (step 308). Processing by the PC or NC of the IP packet data and

Ethernet packets is the same as in PCs on a LAN that share modems and dial up connections to the internet through ISPs, and that technology is incorporated by reference.

[0216] Reception and Distribution of Analog Video Broadcasts Via Satellite or Terrestrial Antenna

[0217] One of the advantages of the gateway **14** is that it may also be used to distribute analog TV broadcasts to TV's throughout the house using the LAN thereby eliminating the need for separate wiring.

[0218] Tuner **314** starts this process by receiving control data from microprocessor **128** defining which C-band analog video channel has been requested by the user. Tuner **314** can be any conventional C-band satellite tuner modified so as to accept digital control data from the host **128** to control which satellite and which transponder to tune to as opposed to receiving this information directly from a remote control or front panel switches. In the home network described herein, users request C-band broadcast channels via their IR keyboards **34** or remote controls **80** in **FIG. 3**. These requests are encapsulated into management and control Ethernet packets addressed to host CPU **128** by network adapter **30**. The host CPU receives them and generates a PCI bus packet on bus **156** addressed to tuner **314** telling it which channel to tune, i.e., which satellite to turn the dish to and which transponder or channel in the downlink broadcast to tune to.

[0219] The RF (or IF) output of tuner **314** on bus **134** is then digitized by an analog-to-digital converter **316**. The digital samples on line **318** are input to a video demodulator **320** which functions in the digital domain to demodulate the digitized analog video signal by removing the RF component. The video demodulator **320** outputs digital data on line **322** which represents a conventional baseband NTSC, PAL or SECAM format video signal.

[0220] The digital data on line **322** is at too high a bit rate to send over the LAN since uncompressed broadcast video consumes about 221 Mbps of bandwidth. Therefore, the video data must be compressed. MPEG II compression is preferred, but any known form of compression currently known or to be developed in the future will suffice since the form of compression is not critical. MPEG II compression circuitry is well known, and is used for MPEG encoder **326**. However, MPEG compression does not compress NTSC, PAL or SECAM format signals. They must first be converted to YUV format luminance and chrominance signals. This conversion is done in video decoder **324**, which is a known type of circuit in any video system that uses MPEG II compression.

[0221] The compressed video data is encapsulated into PCI (or other type) bus packets addressed to IP video circuit **158** on **FIG. 4A**. There, the compressed video data is encapsulated into IP packets addressed to the network adapter of the TV where the request originated and the satellite C-band video channel is to be viewed. The IP video circuit **158** determines which IP destination address to use in constructing the IP packets via data received from the host microprocessor **128**. When the original request was received, the host microprocessor **128**, in addition to telling the tuner **314** which channel to tune, also determines from the source address of the Ethernet packet bearing the request which TV's network adapter requested the data. The IP address of this network adapter is encapsulated into a PCI

bus packet and transmitted via host bus **156** to the IP video circuit. The IP packets encapsulating the digitized C-band video channel are then transmitted via bus **160** to the routing circuit **86**. Bus **160** may simply be the host bus **156** in embodiments where the routing process is carried out in software on the host **128**.

[0222] The routing process **86** is a conventional IP to Ethernet routing process which examines the IP packet destination addresses and looks up the corresponding Ethernet addresses. The IP packets are then encapsulated into Ethernet packets and routed to the appropriate LAN network interface card for LAN **18** or **20** depending upon the Ethernet destination address of each packet. The process works in reverse for incoming Ethernet packets from the LAN(s).

[0223] When the IP packets reach the network adapter of the TV that requested the CATV channel, they are converted to a video signal that can be displayed by the TV by the circuitry described above in conjunction with the discussion of **FIG. 5**.

[0224] Terrestrial Broadcast Reception

[0225] Reception and distribution of standard TV broadcasts received over an antenna coupled to the gateway **14** is very similar. A standard TV antenna **328** is coupled to the gateway by a coax or twinlead wire **330**. A TV tuner **332** tunes the requested channel and outputs the desired channel as an RF or IF signal. Tuner **332** can be a conventional TV tuner modified to receive digital control data from the host computer **128** which controls which analog TV broadcast channel the tuner selects.

[0226] A/D converter **334** samples the output RF or IF and feeds the samples to a video demodulator **336**. There the signal is demodulated in the digital domain to remove the RF component. As is the case for all the analog signal receiver circuits for both HFC and satellite, the analog-to-digital conversion can happen anywhere along the line of circuits including just before the MPEG encoder.

[0227] The output **338** is a digitized version of an NTSC or PAL or SECAM signal. It is fed to a video decoder **340** which converts it to a YUV format. The YUV signal is then compressed by MPEG encoder **342** and put into bus packets of the format used on the host bus **156** (typically PCI) and addressed to the IP video circuit **158**.

[0228] The IP video circuit strips off the bus packet headers (and may perform error detection and correction) and encapsulates the compressed video data from the PCI bus packets into IP packets addressed to the network adapter of the TV set where the requested channel is to be viewed. The IP packets are then sent to the router **86** where the destination address is looked up and the IP packets are encapsulated into Ethernet packets addressed to the same network adapter and launched onto the appropriate LAN.

[0229] LAN Alternative Embodiments

[0230] Video is isochronous or stream-oriented. On the other hand, traditional LAN traffic is more bursty. LANs were not developed to support streaming traffic, and it is therefore possible that a 10 Mbps 10Base-T Ethernet LAN will not have sufficient bandwidth at times to support the load, especially where there are multiple TVs each requesting a different channel along with other simultaneous traffic

sharing the 10 Mbps bandwidth. Video is highly bandwidth intensive so even 100 Mbps LANs have trouble supporting high quality video intermingled with more traditional LAN data traffic.

[0231] Accordingly, it is within the scope of the genus of the invention to use higher capacity LANs for LANs **18** and **20**. Specifically, these LAN can be Fast Ethernet, Switched Ethernet, FDDI, ATM and Fibre Channel Arbitrated Loop. Such LANs are described in Tanenbaum and Horak, supra, and Kembel, *Arbitrated Loop*, Connectivity Solutions, a division of Northwest Learning Associates, Inc of Tucson, Ariz., (1997) ISBN 0-931836-82-4.

[0232] Reception and Distribution of DirecTV Digital Video Broadcasts

[0233] The gateway will include a bus slot for a module which can receive regularly scheduled DirecTV and other format digital video broadcasts on downlinks from a satellite. A tuner **344** serves to receive digital control information from host microprocessor as to which channel on the downlink a user has requested. The tuner then tunes to this channel and rejects all other signals and a QAM demodulator demodulates the signal to recover the transmitted data and outputs a complex baseband signal on line **348**. Conventional QAM modulated digital data receivers are taught in Lee & Messerschmitt, *Digital Communications, 2d Ed.*, (Kluwer Academic Publishers 1994) ISBN0-7923-9391-0, Section 6.4.3, pp. 203-208 and FIGS. 6-18 and 6-19, the entirety of this book being hereby incorporated by reference. Typically, the tuner **344** will be comprised of a bandpass filter to tune the desired channel and reject out-of-band signals and doubling as an anti-aliasing filter. Typically, the signal is then digitized and a phase splitter (a filter that passes only frequency components in the positive half of the Fourier spectrum and rejects Fourier components in the negative half) acts in the discrete time domain to remove the negative half Fourier frequency components of the received spectrum to output an analytic signal. Then the positive half frequency components of the received signals are demodulated, i.e., the RF carrier component is removed by mixing with a local carrier which is synchronized to the transmitted carrier.

[0234] FIG. 6-16 of Lee et al. at p.204 illustrates three different configurations for a QAM tuner.

[0235] The function of the QAM demodulator **346** is to detect the actual symbols sent. This is typically done by sampling and slicing. A complete QAM tuner to get the receive signal back to baseband and demodulator to recover the transmitted symbols is shown in FIG. 6-18(b) of Lee & Messerschmitt for the real valued case and is comprised of two mixers which move the received spectrum back to baseband by multiplying by quadrature shifted local carriers and two receive bandpass filters to reject out of band signals and pass only the positive half Fourier components of inphase and quadrature signals. The I and Q signals are then sampled at the symbol rate and passed through a slicer to recover the symbols actually transmitted. A more complete representation of a practical QAM receiver including both precursor equalization and postcursor equalization and carrier and timing recovery is shown in FIG. 6-23 of Lee & Messerschmitt. Preferably there will also be an error detection and correction circuit as well (not shown).

[0236] After the symbols of the compressed video program are recovered, a conventional transport demultiplexer

350 receives digital control input from the host as to which subchannel on which to find the video program which has been ordered and demultiplexes the audio, video and any associated data from those subchannels.

[0237] To help manage the load on the LAN, an optional transcoder **352** is used to translate the bit rate of the compressed video down to a lower rate when necessary because of current loading conditions on the LAN. Transcoders are known and were commercially available from Imedia in San Francisco, Calif. and now from the assignee of the present invention.

[0238] The output data of the transcoder is supplied to a conventional conditional access circuit **354** which decrypts the data if the subscriber is authorized to receive the program. Alternatively, the conditional access circuit **354** may function to decrypt the original encrypted data if the user is an authorized subscriber and then re-encrypt the data before transmission on the LAN using the new **C5** encryption standard. The re-encrypted data is then packetized into bus packets and transmitted over the host bus **156** to the IP video circuit **158**. There it is encapsulated into IP video packets addressed to the network adapter that requested the program and sent over data path **160** to the routing circuit/process **86**. The routing process looks up the destination address and maps it to the LAN address of the network adapter and encapsulates the data into Ethernet packets and sends them to the correct NIC for transmission over the LAN. At the network adapter, the packets are processed as previously described in connection with the description of FIG. **5** to convert the data to NTSC, PAL or SECAM video signals and the corresponding synchronized audio. If **C5** encryption is used, the data remains encrypted at all stages until it is converted to analog video and audio signals.

[0239] A conventional DirecTV receiver modified to receive digital control data telling it which channel and subchannel to tune can be substituted for tuner **344**, QAM demodulator **346** and transport demultiplexer **350**. Alternatively, the satellite receiver taught in U.S. Pat. No. 5,983,071 may be used but modified to remove the audio decoder **160**, the D/A converter **164**, the video decoder **170** and the NTSC encoder **174**. Those functions all happen at the network adapter after distribution over the LAN. If the receiver of U.S. Pat. No. 5,983,071 is substituted for the tuner **344**, QAM demodulator **346** and transport demultiplexer **158** and the conditional access circuit **354**, the audio and video output stream on lines **162** and **172** of the patent will be supplied to the transcoder **352**. The receiver taught in U.S. Pat. No. 5,983,071 may also be used in place of tuner **102**, A/D matrix **130**, QAM demodulator **146**, conditional access circuit **126** and transport demultiplexer **148**. Again, this receiver will be modified to remove the following components taught in the patent: audio decoder **160**, the D/A converter **164**, the video decoder **170** and the NTSC encoder **174**. Those functions all happen at the network adapter after distribution over the LAN. A transcoder may also optionally substituted into the HFC digital video receiver module circuit that includes tuner **102**, and the conditional access circuits **126** and **186** may both be modified as described above to re-encrypt the recovered data under the **C5** standard to prevent digital copies from being made. If the receiver of U.S. Pat. No. 5,983,071 is substituted for the tuner **102**, QAM demodulator **130** and transport demultiplexer **148** and the conditional access circuit **126**, the audio and video

output stream on lines **162** and **172** of the patent will be supplied to either a transcoder, if present, or to bus interface circuitry (not shown) which packetizes it and sends it to the IP video circuit **158** over the host bus.

[0240] Pay Per View Push Technology Gateway Compatibility

[0241] The gateway **14** can also be used to receive pay per view or free regularly scheduled broadcasts of digital or analog video programs. Push technology means a video server at or coupled to the HFC headend, ADSL CO or satellite uplink has a regular schedule of video programs that it outputs at specific times on specific channels. A menu displayed on the television set in the manner described elsewhere herein or publication is used by the user to select the program the user wishes to view. The user selects the program she wishes to view at the time the program is supposed to start by entering the program number (the program number can be mapped to the service provider and the video server IP address or that information can be entered manually) on her remote control **80** or keyboard **34**. That program number is encapsulated into an Ethernet request packet and transmitted to the gateway where it is routed to the host. The host **128** then sends the appropriate command data over the host bus to tuner **102**, or **100** or **180** or **314** or **344** or **332** or ADSL modem **182** to tune to the appropriate channel, depending upon which medium the program will be arriving. In the case of digital video, the host also sends control packets to the transport demultiplexer **350** or **184** or **148** to control them to demultiplex the compressed video and audio signals off the correct subchannels. If transcoders are used in the digital or analog video receiver modules, the host will monitor the load status of the LAN in any known way and send appropriate control packets to the transcoders over the host bus to control the bit rate of the compressed video transmitted over the LAN so as to not exceed the available bandwidth under varying load conditions.

[0242] IP Telephony

[0243] Since there is a LAN to run throughout the customer premises, it is useful to use the LAN to distribute video and audio and FAX telephony data to the video phones, telephones, FAX machines and FAX modems throughout the premises. Also, since all these physical telephony devices are coupled to a computer, it is useful to include an IP and/or PBX telephony module **352353** in the gateway to provide functionality that the user could not formerly obtain from POTS service. POTS service can provide conference calling, call forwarding, caller ID, voice mail and pager notification of voice mail messages as well as other services through facilities such as Centrex provided by the CO switch. However, these services all cost extra money, and can be implemented locally in the gateway through use of "PBX on a card" expansion circuitry to extend the functionality of the host. Such telephony circuitry **352** to extend the functionality of DOS and Windows based personal computers to include PBX functionality, voice mail and a host of other features is commercially available as the VS1 and Incline systems from Picazo Communications, Inc. of San Jose, Calif. and from Netphone, Inc. of Marlborough, Mass., and Altigen Communications, Inc., the details of which are hereby incorporated by reference. The Netphone PBX on a card technology which can be used to implement

circuit **352** is described in U.S. Pat. No. 5,875,234 which is hereby incorporated by reference. This patent basically teaches a PBX circuit on an expansion card that is coupled to the host bus of a network server. The PBX card can establish and maintain telephone calls and do normal PBX call control functions. The PBX card can be controlled from telephony enabled applications on the server/gateway or by telephony enabled applications running on PCs via the LAN connection to the gateway. Any known expansion circuitry to add PBX functionality to a LAN server regardless of whether it is implemented one circuit board or more than one may be used for circuit **352**.

[0244] Typically, the circuit **352** will have its own switching circuit for connecting phone calls from extension phones coupled to conventional phone lines to CO trunk lines **58** and vice versa.

[0245] In some embodiments, the PBX functionality alone may be sufficient. However, use of the internet for telephony is a growing market, and websites such as www.net2phone.com already exist to allow long distance telephone conversations to take place over the internet regardless of distance for 10 cents per minute. To allow users to take advantage of these services, PCs on LANs **18** and **20** will need to be equipped with microphones and speakers. In such a class of embodiments, the IP & PBX telephony circuit **352** will include circuitry to digitize analog voice signals arriving from the extension phones via conventional phone lines **354**. The IP & PBX telephony circuit **352** may also include packetization circuitry in some embodiments to receive Ethernet packets carrying digitized voice from the PCs on LANs **18** or **20** from router **86** via bus **356** and packetize them into IP packets addressed to the internet server providing the IP telephony services. These IP packets are then sent back over bus **356** to router **86** where they are routed to the server identified in the destination address of the IP packet. The routing can be least cost routing if multiple high bandwidth upstream media such as HFC and ADSL upstream high speed internet access modules such as DOCSIS modem **70** and ADSL modem **182** are present in the gateway. In other embodiments, the PBX expansion module **352** will do call control switching and provide other services between extension lines **354** and the CO trunk lines, and analog telephone signals from the extension phones on line **354** will be digitized and packetized into an IP packet addressed to an IP telephony server on the internet whose IP address is fixed and known to be the IP address to which the telephone data from the conventional POTS telephones is to be directed.

[0246] Then, instead of sending data from Ethernet packets bearing telephony data from PCs, telephones and FAX machines on the LAN for encapsulation into IP packets by the IP & PBX telephony module **352**, the IP packet encapsulation will be done at the source. In other words, if PC **22** or phone **60** or FAX **64** at the customer premises wants to send data to an IP telephony server on the internet, the digital data generated by the source device will be encapsulated by the source device into IP packets addressed to the IP telephony server on the internet. These packets will then be encapsulated into Ethernet packets and sent to the gateway **14**. The gateway **14** will then strip off the Ethernet packet headers and rout the enclosed IP packets to the server on the internet to which they are addressed via the DOCSIS modem **70**, the ADSL modem **182** or possibly by the

conventional modem **280** in **FIG. 4A** (although use of the conventional modem would only make sense if higher bandwidth upstream media was not available).

[0247] Modular Construction of Gateway

[0248] Referring to **FIG. 8**, there is shown a block diagram illustrating the software architecture and modular construction of the gateway/LAN server **14**. As mentioned above, in alternative embodiments, the gateway **14** may actually be comprised of two or more servers to divide the labor but each coupled to the expansion modules by a bus/LAN structure **156**. For example, one server may run only the PBX control software and IP telephony software and another server may run only the management and control and routing process needed for the push and pull video applications and high speed internet access and perform any routing functions needed for IP telephony by the first server.

[0249] The software processes in the host or server run in conjunction with the operating system **358** and use its application programmatic interfaces (API) for message transfers between processes and to send data to the LAN interface or NIC **360** and the host bus **156**. The data paths between the various software processes and between the various processes and NICs **362** and **364** and the host bus **156** through the operating system are symbolized by data path **366**. This data path represents any of the typical methods and apparatus for transferring data between processes or between processes and circuits in the gateway. For example, NIC #**1362** may receive an Ethernet packet bearing a request for a video-on-demand program that is addressed to the management and control process. One way NIC **362** can transfer that packet to the routing process **86** by writing the data into on-board scratchpad RAM and invoking a software interrupt for the routing process **86** and passing it a pointer to the message in RAM. The routing process then executes an interrupt service routine for that interrupt and reads the data from the scratchpad RAM at the address passed with the interrupt or at some preassigned address stored in an interrupt table. Processes and circuits can also pass messages by writing them into predetermined locations in shared address space in RAM **129** with the destination circuit or process and then setting an interrupt bit and storing an interrupt number in a register. The interrupt bit causes the host to execute a generic interrupt service routine to retrieve the interrupt number and then look up the interrupt number in an interrupt vector table. The table would return the address of the beginning of an interrupt service routine for that number. Each circuit or process would have an interrupt number and an associated interrupt service routine. The service routine pointed to by the vector table would then be executed and retrieve the data and return it to the process or circuit associated with that interrupt. Each of the expansion modules could pass data or IP packets to the routing process **86** or the IP video process **158** in that way.

[0250] A management and control process **368** receives video-on-demand and other requests for services and data as described in the detailed descriptions of each module. These other requests can include the numbers of CATV or terrestrial channels to tune in or requests for DirecPC or ADSL or HFC high speed internet access. Other data the management and control process will receive in alternative embodiments is LAN available bandwidth status and other network man-

agement type data. In response, the management and control process sends out the appropriate control data to the tuners, transport demultiplexers, transcoders, conditional access circuits, IP video process and other circuits or processes to manage retrieving the requested data and distributing it to the right peripheral or to transmit data upstream on particular upstream channels. These upstream channels may be preassigned or assigned by downstream control messages from the headend or ADSL CO or satellite uplink server.

[0251] The routing process **86** translates between IP and Ethernet or other LAN protocols and functions as previously described. The IP video process **158** encapsulates data sent to over the host bus into IP packets addressed to the proper peripheral device.

[0252] The IP telephony and other telephony enabled and PBX processes represented by block **370** control the IP and PBX telephony expansion module to implement PBX functions, carry out IP telephony etc. For example, there may be 5 conventional or LAN telephones in the home each of which is primarily answered by one person in the family. One of the processes of block **370** may implement direct inward dialing such that each telephone has its own virtual telephone number which an outsider can dial when, for example, they want to talk to teenager Judy without the inconvenience of accidentally talking to her father. Likewise, two extension phones may wish to have a conference call with a phone in some other state. The PBX control software controls the switch in the PBX module **372** to implement any of these desired PBX functions. The IP telephony process carries out IP telephony, by, for example, receiving digital data from conventional POTS phones via telephony module **372** and encapsulates it into IP packets which are passed to router **86** and vice versa. IP packets received from LAN enabled telephones **60** and **62** are just passed directly to the router **86**.

[0253] Likewise, a database program or word processing program being run on a PC or NC out on the LAN may be telephony enabled. For example, a rolodex file made by a word processing program may contain telephone numbers and the user may look up a person by name and then double click on the phone number. This double click will be converted by the telephony enabled application into an Ethernet packet requesting that the telephone number be dialed. This Ethernet packet is sent to NIC **362** or **364** and is there passed up to the router **86**. The router strips the Ethernet header off and passes the data of the request to a PBX application represented by block **370**. The PBX application makes a function call to a library program of the OS **358** through the standard TAPI interface **374**.

[0254] The TAPI interface represents a collection of pre-defined Windows function calls, each of which invokes a library program from a telephony dynamic linked library of programs. The TAPI function calls provide a standard telephony programmatic interface to applications that want to perform telephone functions. The basic level of functions allow application programs to carry out basic inbound and outbound voice and data calls by providing programs that can be invoked to initialize and open and close TAPI lines, read and write various parameters that control a line device, handle the details of placing an outbound voice or data call or answer an inbound voice or data call, recognize, translate and or build telephone "addresses" or dialing strings,

manipulating call handles etc. Other programs in the TAPI library provide more advanced functions such as digit or tone generation and detection, call acceptance and rejection, redirection, call forwarding, park, hold, conference, etc. if the These advanced features are called supplemental telephony services and allow multiple telephone handsets or other line devices to share only a single CO trunk line or to share multiple CO trunk lines in a PBX type arrangement. The trunk lines can be analog, T1, ISDN or DSL. Because TAPI also supports the logical construct of phone devices, the NCs and PCs out on the network with TAPI libraries can actually have multi-line virtual telephones implement in code running thereof so that every room with a PC in it can also have a multi-line phone capable of speakerphone, conference, hold, park, call forwarding and other advanced capabilities not normally on standard home telephones.

[0255] TAPI services focus on "line devices" as a means for transporting information from one place to another. A line device can be a standard telephone handset, a fax board, a data modem, a telephony card or any physical device coupled to a telephone line. In the system depicted in FIG. 8, the ADSL modem module 378, conventional modem module 380 and IP and PBX telephony module 372 are all line devices. Because a line device is a logical construct, TAPI can see multiple line devices all coupled to the same physical telephone line. A TAPI call control program (dialer.exe) can accept multiple simultaneous TAPI service requests from, for example, the PBX application, the IP telephony application and other telephony enabled applications all represented by block 370 and queue them all for service in order.

[0256] Communications between the application programs and the TAPI library are by the Windows messaging function using predefined TAPI data structures. Telephony libraries of other operating system may be substituted for the Window TAPI library and the data structures and messaging functions of the operating system in use can be substituted.

[0257] How TAPI is structured and how application programs can be written to utilize this resource are all defined in Amundsen, MAPI, SAPI & TAPI *Developer's Guide*, (SAMS Publishing 1996) ISBN 0-672-30928-9, which is hereby incorporated by reference.

[0258] Returning to the current example, the TAPI program executes and makes a function call to the telephone service provider process 376 and passes it the number to be dialed. The TSP layer 376 isolates the TAPI library program from needing to know the details of the specific hardware installed and it isolates the particular hardware which is installed from having to be designed for the specific telephony enabled application programs which are present. It is translator between the TAPI world and the hardware world. In other words, the TSP layer 376 implements the TSPI functions that are used by TAPI implementation. Each TSP then uses whatever interface is appropriate to control the telephony hardware to which it is connected. The TSP layer 376 and the PBX card driver layer 378 actually can be combined in some embodiments, and in other embodiments, the TSP layer can be used to interface to other telephony hardware such as a FAX modem expansion module 380 at the gateway by which FAXes may be sent using data received from PCs that do not have FAX modems or connections to telephone lines available at their location on the network.

[0259] Assuming the TSP and PBX card drivers are separate processes, either TSP 376 or TAPI program 374 then invokes the proper function call of a PBX card driver process 378 and passes it the number to be dialed. The PBX card driver speaks the specific language of the IP and PBX telephony module 372 and sends it a properly formatted message to control the switch and other circuitry thereon to seize a CO trunk line and generate the appropriate DTMF tones to dial the requested number when a dial tone is detected.

[0260] When the person answers, the voice is digitized by a codec in the PBX card 372 and the data is passed back to the PBX card driver which then passes it back up through all the layers to the router. The router encapsulates the data into an Ethernet packet addressed to the telephone or other line device that made the call and passes the packets to the appropriate NIC. From the NIC, the packets are transmitted via LAN to the network adapter of the telephone or PC or NC that originated the call. The reverse thing happens for voice going out from the PC, NC or telephone which originated the call to the person who answered the phone.

[0261] The host bus is coupled via bus connectors and expansion slots to one or more expansion modules which implement the transmitter and receiver circuitry and other interface circuitry necessary to interface the gateway to the satellite, HFC, POTS or DSL media or any other media such as the power lines or wireless local loops which may be developed in the future. Modules are shown for currently existing technologies only, but newer upstream and downstream media are sure to follow, and the genus of the invention includes expansion modules of whatever type are needed to interface to these newer media.

[0262] The ADSL modem module 378 may be any conventional ADSL modem 182 or SDSL modem or any other modem to interface to any type of digital subscriber line local loop which can be digitally controlled by the host 128. It will include any connectors and isolation circuitry 204 needed to connect to the DSL CO trunk line.

[0263] The FAX/Data Modem Module 380 can be any conventional FAX/Data modem or simple data modem for coupling via suitable connectors and isolation circuitry 205 to extension phone lines 354 within the customer premises as well as DSL CO trunk lines 58 and which can be digitally controlled by the host 128.

[0264] The IP & PBX telephony module 372 can be any known or future developed "PBX on a card" including one or more expansion cards which give a conventional personal computer host 128 running any operating system PBX capabilities and which can be digitally controlled by the host 128. It can include any needed additional known circuitry and software needed to implement IP telephony functions.

[0265] A DOCSIS modem module can be any known or future developed cable modem that conforms to the DOCSIS standard or any new standard for modems that allow high speed data transfers from a customer premises to a headend cable modem and/or the internet over a CATV HFC cable plant, and which can be digitally controlled by the host 128.

[0266] An HFC digital video module 388 can be any digital video receiver which can be digitally controlled by the host 128 and is compatible with reception of digitized

compressed video data transmitted over HFC. In the system of FIG. 4A, for example, the HFC digital video module 388 would typically include tuner 108, an A/D converter included in matrix 130, QAM demodulator 146, transport demultiplexer 148 and conditional access circuit 126 to communicate with the shared IP video process 158 running in software on the host. It may also include the upstream and downstream combiner and isolation circuits 90 and 98 although this combiner and isolation circuitry may be shared by all HFC interface modules in some embodiments.

[0267] An HFC analog video module 390 can be any receiver capable of receiving regularly scheduled analog CATV transmissions over HFC which can digitize and compress the data for transmission over the LAN and which can be digitally controlled by the host 128. In the exemplary embodiment of FIGS. 4A and 4B, the module 390 typically would include tuner 100, an A/D converter from matrix 130, video demodulator 138, video decoder 114 and MPEG encoder 147. It may also include the upstream and downstream combiner and isolation circuits 90 and 98 although this combiner and isolation circuitry may be shared by all HFC interface modules in some embodiments.

[0268] In some species within the genus of the invention, all HFC interface modules such as 386, 388 and 390 may be combined into one HFC interface module. Likewise for all expansion modules that interface to the PSTN and extension phone lines or all modules that interface with the satellite dish.

[0269] A satellite digital video-on-demand module 392 can be any satellite receiver which can be digitally controlled by the host 128 to tune in and receive a specifically requested compressed digital video-on-demand broadcast from a satellite. In the embodiment of FIGS. 4A and 4B, it includes tuner 180, QPSK demodulator 220, transport demultiplexer 184 and conditional access circuit 186.

[0270] A satellite analog video module 394 can be any conventional C-band satellite receiver modified to receive tuning commands digitally from the host 128 and modified to digitize and compress the video program for distribution on a LAN. In the embodiment of FIGS. 4A and 4B, it would include tuner 314, A/D converter 316, video demodulator 320, video decoder 324 and MPEG encoder 326.

[0271] A satellite DirectPC module 396 can be any conventional DirectPC receiver or any equivalent receiver for receiving IP packetized data transmitted from a satellite capable of being digitally controlled by a host computer and send the recovered IP packets to a routing process being run by the host. In the embodiment of FIGS. 4A and 4B, it would include tuner 302 and QPSK demodulator 304.

[0272] A satellite DirecTV module 398 can be any conventional DirecTV receiver or equivalent digital satellite TV broadcast receiver which can receive regularly-scheduled, compressed, digital TV broadcasts from a satellite but modified to be controlled digitally by the host 128 to tune to a requested broadcast channel. In the embodiment of FIGS. 4A and 4B, this module would include tuner 344, QAM demodulator 346, transport demultiplexer 350, optionally transcoder 352 and conditional access circuit 354.

[0273] A terrestrial analog NTSC or PAL or SECAM module 400 can be any receiver capable of being digitally tuned by the host computer which can receive regularly

scheduled analog TV broadcasts via an antenna and digitize and compress them for distribution over a LAN. In the embodiment of FIGS. 4A and 4B, it would include tuner 332, A/D converter 334, video demodulator 336, video decoder 340 and MPEG encoder 342.

[0274] Any of the modules defined above which recover or generate digital data for transmission on the LAN can optionally include a transcoder to translate the original bit rate to a lower bit rate where needed because of network loading. Likewise, any module that recovers digital data that encodes copyrighted materials such as video or audio programs may include a C5 standard encryption circuit to re-encode the digital data before transmission on the LAN to prevent perfect, unauthorized digital copies which could happen if the digital data were to be transmitted in the clear.

[0275] Although the invention has been disclosed in terms of the preferred and alternative embodiments disclosed herein, those skilled in the art will appreciate possible alternative embodiments and other modifications to the teachings disclosed herein which do not depart from the spirit and scope of the invention. All such alternative embodiments and other modifications are intended to be included within the scope of the claims appended hereto.

What is claimed is:

1. A gateway apparatus comprising:

a host computer having a host bus;

one or more local area network interfaces coupling said host computer to one or more local area networks than carry data between said gateway and one or more devices located within a customer premises;

one or more external network interface circuits coupled to said host bus for interfacing said host computer to one or more networks external to said customer premises which deliver analog and/or digital video and other digital data to said customer premises; and

wherein said host computer is programmed to implement an IP packetization process to receive data from said external network interface circuits and packetize it into IP packets, and programmed with a routing process to receive IP packets from said IP packetization process and encapsulate them into local area network packets and transmit them on the appropriate local area network via one or more of said local area network interfaces and for receiving local area network packets from devices coupled to said local area networks and stripping off the local area network packet headers and routing the encapsulated IP packets to the appropriate external network interface circuit for transmission over an external network, and a management and control process for receiving requests for data from said devices coupled to said local area networks and sending digital control data to said external network interface circuits to control them to obtain said data.

2. The apparatus of claim 1 wherein said IP packetization process controls said host computer to receive data from said one or more external network interface circuits which is not already in the form of an internet protocol packet and packetizing said data into an internet protocol formatted packet addressed to a device coupled to one or more of said local area networks.

3. The apparatus of claim 1 wherein said routing process controls said host computer to receive internet protocol formatted packets either from said IP packetization process or directly from an external network interface circuit and, with said network interface, look up the Ethernet address of the device coupled to said local area network that corresponds to the internet protocol packet's destination address, and do all the protocol conversions necessary to encapsulate each said internet protocol packet into one or more Ethernet local area network packets addressed to a device which requested data in said internet protocol packet and transmit same over the appropriate local area network to the device which requested said data, and further controls said host computer to receive Ethernet packets from devices coupled to said local area networks that include internet protocol packets via said local area network interface(s) and do all the protocol conversions necessary to strip off the Ethernet packet header and route the encapsulated internet protocol packet to the appropriate external network interface circuit for transmission on an external network to the server to which the internet protocol packet is addressed.

4. The apparatus of claim 1 wherein said management and control process is structured to control said host computer to receive Ethernet packets from devices coupled to said local area network(s) which contain requests to download specific web pages at URLs identified in said packet or to receive and distribute regularly scheduled video broadcasts over a CATV hybrid fiber coaxial cable system, a satellite downlink or a terrestrial broadcast, or to request a video program to be delivered over said CATV hybrid fiber coaxial cable system or said satellite downlink or via a digital subscriber line local loop, and generating and sending appropriate control data to the appropriate one of said external network interface circuits to cause the requested data or video broadcast or video-on-demand program to be received.

5. The apparatus of claim 1 wherein said one or more external network interface circuits comprises a digital subscriber line modem.

6. The apparatus of claim 1 wherein said one or more external network interface circuits comprises a conventional POTS line fax and/or data modem.

7. The apparatus of claim 1 wherein said one or more external network interface circuits comprises an internet packet telephony circuit to interface said gateway to plain old telephone service and/or digital subscriber line phone lines from a public service telephone network central office.

8. The apparatus of claim 1 wherein said one or more external network interface circuits comprises a private branch exchange (PBX) telephony circuit for interfacing said gateway to one or more plain old telephone service (POTS) telephone lines which are internal or external to said customer premises and/or one or more digital subscriber line (DSL) phone lines from a public service telephone network central office, said PBX telephony circuit including a switch controlled by a plurality of processes controlling said host computer to implement PBX telephony functions for line devices such as telephones coupled to said one or more POTS or DSL lines or to said local area network, said processes including a PBX application process, one or more processes implementing a TAPI dynamic linked library and a PBX card driver process.

9. The apparatus of claim 1 wherein said one or more external network interface circuits comprises a cable modem for interfacing said gateway to a CATV hybrid fiber coaxial cable system connection.

10. The apparatus of claim 9 wherein said cable modem is compatible with the DOCSIS 1.2 national standard for cable modems as that standard existed as of the filing date of this patent application.

11. The apparatus of claim 1 wherein said one or more external network interface circuits comprises a receiver for interfacing said gateway to a CATV hybrid fiber coaxial cable system connection, said receiver capable of receiving and demodulating and recovering digitized, compressed video-on-demand program data modulated onto a downstream carrier requested by a device coupled to said local area network and demultiplexing the audio and video components and transmitting the recovered data to said IP packetization process via said host bus.

12. The apparatus of claim 1 wherein said one or more external network interface circuits comprises a receiver for interfacing said gateway to a CATV hybrid fiber coaxial (HFC) cable system connection, said receiver capable of receiving analog video transmissions on said HFC requested by a device coupled to said local area network and digitizing and demodulate said analog video transmissions and then encoding the resulting data into a format in which it can be compressed, and then compressing the data and transmitting it via said host bus to said IP packetization process.

13. The apparatus of claim 1 wherein said one or more external network interface circuits comprises a receiver for interfacing said gateway to a satellite dish and receiving compressed digital data encoding a regularly scheduled television program modulated onto a downlink carrier requested by a device coupled to said local area network and demodulating and recovering said digital data and demultiplexing the audio and video data therefrom and transmitting said recovered digital data via said host bus to said IP packetization process.

14. The apparatus of claim 1 wherein said one or more external network interface circuits comprises a receiver for interfacing said gateway to a satellite dish and receiving compressed digital data encoding a video-on-demand television program modulated onto a downlink carrier requested by a device coupled to said local area network and demodulating and recovering said digital data and demultiplexing the audio and video data therefrom and transmitting said recovered digital data via said host bus to said IP packetization process.

15. The apparatus of claim 1 wherein said one or more external network interface circuits comprises a receiver for interfacing said gateway to a satellite dish and receiving analog regularly scheduled television programs modulated onto a downlink carrier requested by a device coupled to said local area network and demodulating and digitizing said television signals and encoding the digital data into a format that can be compressed and compressing said digital data and transmitting said compressed digital data via said host bus to said IP packetization process.

16. The apparatus of claim 1 wherein said one or more external network interface circuits comprises a receiver for interfacing said gateway to a satellite dish and receiving digital data encoding a web page or other information from the internet and encapsulated into internet protocol packets requested by a device coupled to said local area network and

that have been modulated onto a downlink carrier and demodulating and recovering said internet protocol packets and transmitting them via said host bus to said routing process.

17. The apparatus of claim 1 wherein said one or more external network interface circuits comprises a receiver for interfacing said gateway to a conventional terrestrial broadcast television antenna and receiving a regularly scheduled television program signal requested by a device coupled to said local area network and modulated onto a terrestrial broadcast carrier and demodulating said signals digitizing said signals and encoding the digital data into a format that can be compressed and compressing the digital data and transmitting said compressed digital data via said host bus to said IP packetization process. TER-008 claims #2.

18. A gateway apparatus comprising:

a host computer having a host bus;

one or more local area network interface means for coupling said host computer to one or more local area networks than carry data between said gateway and one or more devices located within a customer premises;

one or more external network receiver means coupled to said host bus for interfacing said host computer to one or more networks external to said customer premises by receiving analog signals and digitizing and compressing them and supplying the compressed data to said host computer or receiving and recovering video and other data in digital form which has been modulated onto a downstream carrier for transmission to said customer premises and supplying the recovered digital data to said host computer;

one or more external network transceiver means coupled to said host bus for interfacing said host computer to one or more networks external to said customer premises by receiving analog signals and digitizing and compressing them and supplying the compressed data to said host computer or receiving and recovering video and other data in digital form which has been modulated onto a downstream carrier for transmission to said customer premises and supplying the recovered digital data to said host computer and include an upstream transmitter for receiving digital data from said host computer and transmitting it outbound on an external network; and

wherein said host computer is programmed to implement an IP packetization process to receive data from said external network interface circuits and packetize it into internet protocol (IP) formatted packets, and programmed with a routing process to receive IP packets from said IP packetization process and encapsulate them into local area network packets and transmit them on the appropriate local area network via one or more of said local area network interfaces and for receiving local area network packets from devices coupled to said local area networks and stripping off the local area network packet headers and routing the encapsulated IP packets to the appropriate external network interface circuit for transmission over an external network, and an IP telephony and other processes to control said host computer to control line devices coupled to standard or DSL telephone lines or local area networks coupled to said gateway or line devices and other external network

interface circuits coupled to said host computer via said host bus to implement IP telephony functions, and a management and control process for receiving requests for data from said devices coupled to said local area networks and sending digital control data to said external network interface circuits and/or line devices to control them to obtain said data.

19. The apparatus of claim 118 wherein said one or more local area network interface means are Ethernet local area network interface cards and wherein said routing process controls said host computer to receive internet protocol formatted packets either from said IP packetization process or directly from an external network interface circuit and, with said network interface, look up the Ethernet address of the device coupled to said local area network that corresponds to the internet protocol packet's destination address, and do all the protocol conversions necessary to encapsulate each said internet protocol packet into one or more Ethernet local area network packets addressed to a device which requested data in said internet protocol packet and transmit same over the appropriate local area network to the device which requested said data, and further controls said host computer to receive Ethernet packets from devices coupled to said local area networks that include internet protocol packets via said local area network interface(s) and do all the protocol conversions necessary to strip off the Ethernet packet header and route the encapsulated internet protocol packet to the appropriate external network transceiver means for transmission on an external network to the server to which the internet protocol packet is addressed.

20. The apparatus of claim 18 wherein said one or more external network transceiver means comprises a private branch exchange (PBX) telephony means for interfacing said gateway to one or more plain old telephone service (POTS) telephone lines which are internal or external to said customer premises and/or one or more digital subscriber line (DSL) phone lines from a public service telephone network central office, said PBX telephony means including a switch controlled by a plurality of processes controlling said host computer to implement PBX telephony functions for line devices such as telephones coupled to said one or more POTS or DSL lines or to said local area network, said processes controlling said host computer including a PBX application process, one or more processes implementing a TAPI dynamic linked library and a PBX card driver process.

21. The apparatus of claim 18 wherein said management and control process is structured to control said host computer to receive Ethernet packets from devices coupled to said local area network(s) which contain requests to download specific web pages at URLs identified in said packet or to receive and distribute regularly scheduled video broadcasts over a CATV hybrid fiber coaxial cable system, a satellite downlink or a terrestrial broadcast, or to request a video program to be delivered over said CATV hybrid fiber coaxial cable system or said satellite downlink or via a digital subscriber line local loop, and generating and sending appropriate control data to the appropriate one of said external network transceiver means to cause the requested data or video broadcast or video-on-demand program to be received.

22. The apparatus of claim 18 wherein said one or more external network transceiver means comprises a digital subscriber line modem means for interfacing said gateway to a digital subscriber line local loop.

23. The apparatus of claim 18 wherein said one or more external network transceiver means comprises a conventional POTS line fax and/or data modem means for interfacing said gateway to said conventional POTS telephone line to the central office of the public service telephone network.

24. The apparatus of claim 18 wherein said one or more external network transceiver means comprises an internet packet telephony means for interfacing said gateway to plain old telephone service and/or digital subscriber line phone lines from a public service telephone network central office.

25. The apparatus of claim 18 wherein said one or more external network transceiver means comprises a cable modem means for interfacing said gateway to a CATV hybrid fiber coaxial cable system connection.

26. The apparatus of claim 25 wherein said cable modem is compatible with the DOCSIS 1.2 national standard for cable modems as that standard existed as of the filing date of this patent application.

27. The apparatus of claim 18 wherein said one or more external network transceiver mean comprises means for interfacing said gateway to a CATV hybrid fiber coaxial cable system connection to request a specified video-on-demand program via an upstream message and for receiving and demodulating and recovering digitized, compressed video-on-demand program data modulated onto a downstream carrier requested by a device coupled to said local area network and demultiplexing the audio and video components and transmitting the recovered data to said IP packetization process via said host bus.

28. The apparatus of claim 18 wherein said one or more external network receiver means comprises means for interfacing said gateway to a CATV hybrid fiber coaxial (HFC) cable system connection to make said gateway capable of receiving analog video transmissions on said HFC requested by a device coupled to said local area network and digitizing and demodulating said analog video transmissions and then encoding the resulting data into a format in which it can be compressed, and then compressing the data and transmitting it via said host bus to said IP packetization process.

29. The apparatus of claim 18 wherein said one or more external network receiver means comprises a means for interfacing said gateway to a satellite dish and receiving compressed digital data encoding a regularly scheduled television program modulated onto a downlink carrier requested by a device coupled to said local area network and demodulating and recovering said digital data and demultiplexing the audio and video data therefrom and transmitting said recovered digital data via said host bus to said IP packetization process.

30. The apparatus of claim 18 wherein said one or more external network transceiver means comprises a conventional modem means for making a dialup connection to a satellite uplink facility or video server and sending a message requesting delivery of a specified video-on-demand selection, and receiver means for interfacing said gateway to a satellite dish and receiving compressed digital data encoding a video-on-demand television program modulated onto a downlink carrier requested by a device coupled to said local area network and demodulating and recovering said digital data and demultiplexing the audio and video data therefrom and transmitting said recovered digital data via said host bus to said IP packetization process.

31. The apparatus of claim 18 wherein said one or more external network receiver means comprises means for interfacing said gateway to a satellite dish and receiving analog regularly scheduled television programs modulated onto a downlink carrier requested by a device coupled to said local area network and demodulating and digitizing said television signals and encoding the digital data into a format that can be compressed and compressing said digital data and transmitting said compressed digital data via said host bus to said IP packetization process.

32. The apparatus of claim 18 wherein said one or more external network receiver means comprises means for interfacing said gateway to a satellite dish and receiving digital data encoding a web page or other information from the internet and encapsulated into internet protocol packets requested by a device coupled to said local area network and that have been modulated onto a downlink carrier and demodulating and recovering said internet protocol packets and transmitting them via said host bus to said routing process.

33. The apparatus of claim 18 wherein said one or more external network receiver means comprises means for interfacing said gateway to a conventional terrestrial broadcast television antenna and receiving a regularly scheduled television program signal requested by a device coupled to said local area network and modulated onto a terrestrial broadcast carrier and demodulating said signals digitizing said signals and encoding the digital data into a format that can be compressed and compressing the digital data and transmitting said compressed digital data via said host bus to said IP packetization process.

34. A gateway apparatus comprising:

a host bus;

a plurality of expansion card connectors electrically coupled to said host bus;

one or more expansion module printed circuit boards coupled to said host bus through one or more of said expansion card connectors, each expansion module including the appropriate circuitry to receive signals from an external network media comprised of either a hybrid fiber coaxial cable of a CATV system, a digital subscriber line local loop, an analog plain old telephone service line or a satellite dish, and to either recover digital data transmitted via said external network media or to receive analog signals transmitted via said external network media and generate digital data therefrom, and, depending upon the type of external network media to which each expansion module is coupled, to also transmit digital data modulated on a carrier signal out on said external network media;

one or more network interface adapters for coupling said gateway to one or more local area networks which convey digital data throughout a customer premises; and

a host computer having a central processing unit or microprocessor coupled to said host bus and programmed to perform at least a management and control process to receive requests transmitted TRANSMITTED from users to said gateway via one or more of said local area networks for data or video or audio programs transmitted on a regularly scheduled or on-demand basis on one of said external network media and to react thereto by appropriately controlling said one or more

expansion modules via data transmitted over said host bus to retrieve the requested data or video or audio program, and programmed to perform an IP packetization process to receive digital data from one or more of said expansion modules and said management and control process and encapsulate said data into an internet protocol packet addressed to the device on a local area network coupled to said gateway which requested said data, and programmed to perform a routing process to receive network packets containing internet protocol packets and to strip off the network packet header and to route said internet protocol packet to the appropriate expansion module for upstream transmission on a external network media and to receive internet protocol packets from one or more of said expansion modules or said IP packetization process and to look up the IP destination address and map it to a local area network address corresponding thereto and encapsulate the internet protocol packet in a local area network packet addressed to the device owning said IP destination address and route it to said device via the appropriate network adapter, and programmed with one or more IP telephony and/or PBX and/or other telephony enabled application programs to implement IP telephony and/or PBX functions through a TAPI dynamic linked library of programs which control said host computer to carry out standard and advanced telephony functions which can be invoked through a standard TAPI application programmatic interface and one or more telephony service provider programs and/or PBX expansion module programs which convert messages from one or more TAPI library programs to digital data sent over said host bus to one or more of said expansion modules to carry out one or more telephony functions.

35. A network adapter for coupling a conventional television to a local area network, comprising:

a network interface circuit having an input coupled to a local area network and having an output at which digital data encoding a compressed video appears and functioning to receive local area network packets encapsulating internet protocol format packets but only

outputting internet protocol format packets encapsulated in local area network packets addressed to this particular network interface circuit;

means for receiving infrared or radio frequency commands and data from a wireless remote control or a wireless keyboard and for packetizing the data and commands into packets suitable for transmission over said local area network;

an internet protocol video circuit coupled to said network interface circuit for receiving internet protocol format packets from said network interface circuit and determining if the packet contains video or graphics data and stripping off the internet protocol format header and outputting graphics data at a graphics data output and outputting video data at a video data output;

a decompression circuit coupled to said video data output for decompressing the video data and outputting uncompressed video data in a YUV format at a first output and uncompressed audio data at second output;

an audio processor means coupled to receive said uncompressed audio data and process it to convert it to an analog audio signal;

a graphics circuit coupled to said graphics output for receiving graphics data and generating graphics data signals at a graphics output;

means coupled to receive said uncompressed video data and said graphics data signals and process both said graphics data signals and said uncompressed video data into NTSC, PAL or SECAM or composite format analog video signal which can be displayed on a television if coupled to a video input of said television; and

optionally, a video modulator for receiving said analog video signal and said analog audio signal and modulating them onto an radio frequency carrier at the frequency of a locally unused channel.

* * * * *