

Feb. 19, 1929.

1,702,607

T. JENSEN

DOUBLE NAIL SET

Filed April 17, 1926

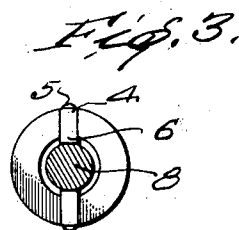
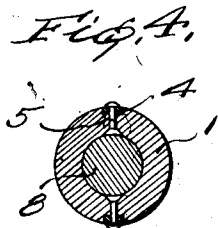
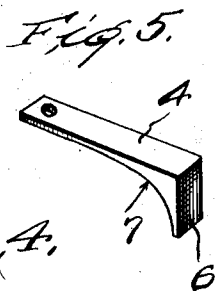
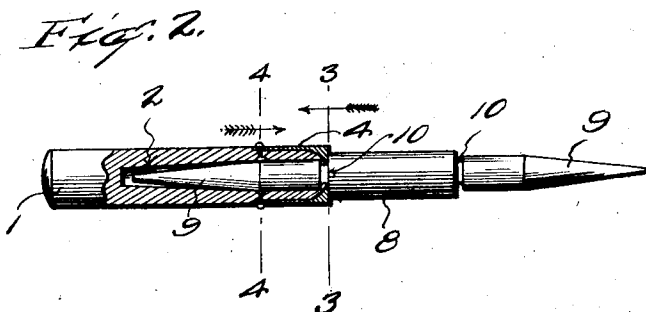
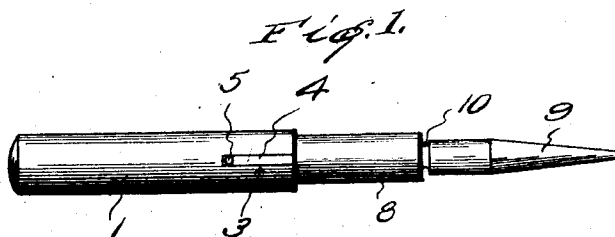

Inventor
THEODORE JENSEN

By Richard B. Owen,

Attorney

UNITED STATES PATENT OFFICE.

THEODORE JENSEN, OF ASKOV, MINNESOTA.

DOUBLE NAIL SET.

Application filed April 17, 1926. Serial No. 102,758.

This invention relates to nail punches and has for its object the production of a simple and efficient punch which is provided with a holder for the purpose of supporting a nail punch having the ends thereof of different sized diameters, wherein the punch may be reversed within the holder for the purpose of facilitating the punching of nails of different sizes.

Another object of this invention is the production of a simple and efficient means for holding the punch within the holder.

With these and other objects in view, this invention consists in the novel construction, combination and arrangement of parts as will be hereinafter fully described and explained.

In the drawings;

Figure 1 is a side elevation of the double nail set, the nail punch being shown mounted within the holder,

Figure 2 is a side elevation of the nail punch, the holder being shown partly in section,

Figure 3 is a section taken on line 3—3 of Figure 2,

Figure 4 is a section taken on line 4—4 of Figure 2 looking in the direction of the arrow,

Figure 5 is a detail perspective view of one of the spring latches which is carried by the holder and which is adapted to engage the punch for locking the same within the holder.

By referring to the drawings, it will be seen that 1 designates the holder which is of a substantially tubular structure having a socket 2 formed longitudinally thereof, the socket tapering toward its inner end as clearly indicated in Figure 2 of the drawing. The holder 1 is provided with a pair of longitudinally extending slots formed within the outer face of the holder 1 for the purpose of receiving the spring latches 4, which latches 4 are secured at their rear ends by means of rivets 5 and in this manner held in engagement with the holder 1. The latches 4 are provided with inwardly extending punch gripping lips 6, the underfaces 7 of the latches 4 being curved for the purpose of facilitating the removal of the punch 8 from engagement with the holder by pulling the same outwardly. These latches, however, under ordinary conditions will hold the punch 8 in engagement with the holder 1 so as to prevent the punch from accidentally dropping from the holder when in use and when it is not desired to remove the punch 8 from the holder. The latches 4 are arranged

diametrically opposite to each other upon the holder 1 as clearly illustrated in Figures 2, 3 and 4.

The punch 8 comprises the centrally arranged body portion having different sized tapering nail punch ends 9 and between the ends 9 is formed an annular groove or channel 10 for the purpose of permitting the lips 6 of the spring latches 4 to engage the same and hold the punch in engagement with the holder 1. As illustrated in Figure 2 it will be seen that the respective ends 9 of the punch 8 are of different size, one being smaller than the other to facilitate the punching of nails of various sizes. It should be understood that in use the punches may be readily removed from the holder 1 and the projecting punch ends 9 reversed to suit the convenience of the operator and that the latches 4 will efficiently hold the punch 8 in engagement with the holder.

It should be understood that certain detail changes in the mechanical construction may be employed without departing from the spirit of the invention, so long as these changes fall within the scope of the appended claim.

Having described the invention, what is claimed is:

In a nail set of the character described, an elongated handle body having a longitudinally extending bore formed therein from one end thereof and further having a pair of longitudinally extending recesses formed in the outer face thereof and each opening into a recess formed transversely of the said bored end, a pair of resilient finger members each arranged in one of said longitudinal recesses and secured in the body and each having a laterally extending thickened terminal head positioned in a transverse recess and flush with the end of the body, and a tool member of pencil like form having a central portion of relatively large diameter and end portions of smaller diameter than the central portion and further having a circumferentially extending groove at the point of joinder between the inner end of each end portion and the central portion, said groove being designed to receive the laterally extending heads of said fingers, the end of the central portion bearing against the head and the adjacent end of the body.

In testimony whereof I affix my signature.
THEODORE JENSEN.