

(19) (KR)
(12) (A)

(51) 。 Int. Cl. 7
H01R 13/436

(11)
(43)

2002 - 0048871
2002 06 24

(21) 10 - 2001 - 0079327
(22) 2001 12 14

(30) JP - P - 2000 - 0038 2000 12 18 (JP)
4528

(71) 가 가

2 - 4 - 8

(72) 가 가 4 4 - 36, 가
가

1 26 - 28 - 301

가 가 4 4 - 36, 가
가

(74)

:

(54)

(211, 221) 2 (210, 220) (100) .
(100) (210, 220) (110) , (110)
1 (210) (211) (121) 2 (220) (221)
(122) (120)

1	1	1			,
2	1	1			,
3	1	1			,
4a	1				,
4b	1				,
4c	1				,
5	1	2			,
7	1	2			,
8	1	1	2		,
9	2	1			,
10	2	1			,
11	2	2			,
12	3				,
13	3	2			,
14	3	1			,
15	3	1	2		,
16	4				.

< >

100 : 110 :

116 : 117 :

118 : 120 :

121 : 122 :

210 : 1 211 :

212 : 212a :

220 : 2 221 :

225 : 225a :

2 , 2

2 , 1 , 가 , 2

1 / 2 ,

2 , 1

2 , 1 , 2

가 , 1 , 2

가 , 가 2 , 1 , 2

가 2 , 가 2 , 1 ,

1 가 2 , 가 2 ,

가 , 가 2 ,

가 1

가 1 2 가 1 2 가 1 2 , ,

(100) (110) (110) (120) (100) (100)
 1 (210) (220) (210) (220) (211) (221)
 , 2 , 2

4a, 4b 4c (110) (110)
 (110) (111) (110) (112) (111) (111) (111)가
 (110) (110) (112) (113) (110) (113) (111)
 3) (111) (120) (112) (112) (11)

5 (210) (211) (120) (121) (220) (221) (120) 1
 (122) (121b) (211) (120) (121) (121a) (120)
 (122)가 (110) (113) U (110) (122)
 (122) 가 (122a) , 2 (220) (221) L
 20) (124) (124) (110) (111) (115) (1

(110) 1 (210) 1 (210) 3 (212)가
 , (110) 1 (212) 가 (100)
 (212) (100) (212) (212) 2 (212)
 122)가 (212) 가 (213)가 (110) (116)
 a) 가 (213)가 (114) (114) 가
 (213) (110) 1 (210) (114) 가
 2). (100) (114) (212) 가 (213)
 (212) 가
 , 가
 , 1 (212,
 225) 가

1 3 (100) (120) (121) 1 (210)
 (211) , (110) 1 (210) , 2 (210), 220)
 (210, 220) (120) (122)가 2 (220) (221)
 (211, 221)가 (120) . 2 (210, 220)
 , 1 (210) 2 (220)

6 7 1 (100) (110) 2
 (220) . 2 (220) (225)가 (110)
 (225) (220) (221) (110)
 (100) (225) (100) (225)
 (225) (122)가 (225)
 가 (225) 2 (225a) (110) (114) 가 (226)
 (114) 가 (226)
 (110) 2 (220)

, (100) (120) (121) 1 (210) (211)
 (110) 2 (220) , (120) (122)가 2 (220) (221)
 (210, 220) (211, 221)가 (120)

8 , 1 (100) (110) 1 (21)
 0) 2 (220) , 1 (210) (212)가, 2 (220)
 (225)가 (110) (221, 225)
 . 2 (220) (221) (225)
 (100) (212) , (100) (212)
 (122)가 (212) , (225) , (100)

(225) (122)가 (225)
 (212, 225) 가 (213, 226)가 , (114) 가 (21
 3, 226) , (110) 1 (210) 2 (220)

(100) (120) (121) 1 (210) (211)
 (110) 1 (210) 2 (220) , (120) (122)가 2 (22
 0) (221) (210, 220) (211, 221)가 (120)

(120) (122)가 2 (220) (221)
 , 가 1
 (211) (100) 1
 (110) 1 (210) 2 (220) ,
 10, 220) 가 (210, 220) , (2 가 1
 가 가

(110) (210) / (220) (212) / (225)
 , (110) (210 / 220) , (100) (210 /
 220) (212 / 225) (100)가 (210 / 220)

(120) 가
 , 가 1
 , 가 1

9 10 2 (100) 2 (100) (110)
 가 (110)
 (117) , (117) (110)
 (110) 2 (116) (110)
 7) 9 10 (110) 1 (210) . (11
 1 (210) 9 10 (212)가 , (110) (212) 가
 , (110) (212) (212) (212a)
 (117) (100) (212) (100)
 (212) (122)가 (212) (100)
 (100) (210, 220) (212) 1 3

11 , 2 (100) , (110) 2
 (220) 2 (220) (225)가 , (110) (2
 25) 가 , (110) (225) (225)
 (225a) (117) (100) (225)
 (100) (225) (122)가 (225)
 (100) (210, 220)

6 7

2 , 1 가 ,
 (117) 가 (212, 225) 가
 (117) (210, 220) (100) (110)
 (117) (117) (110)
 (100)가 (210, 220)

12 3 (100) 3 (100) , (110) (1
 18)가 , (118) (110) (118)
 (110) (118)
 118a) , (118a) 가 13
 (110) 2 (220) 2 (220) (222)
 (118) (110) (122) (100)
 (122)가 2 (220) (221) , (118)가 2 (220)
 (100) (210, 220) 6 7

14 3 (100) , (110) 1
 (210) , 1 (210) (215) , (118) (110)
 (122)가 (100) (1
 22) 1 (210) , (118)가 1 (21
 0) (100) (210, 220) , 1 3

3 , 1 가 ,
 118) (110) (110) (118) (100)가 (210, 220)

2 , (220) , 1 , 2 . 1 (110) 1 (210)
 (210) 1 , 2 (220) 3 , 3 (110) 1
 , 12 , (118) (114) , 1

(210) 가 (213) . , (110) (212)
 . 1 (110) 1 (210) 2 (220) , 1
 , 1 (110) 1 (210) 2 (220)
 , (100) 2 (210, 220)
 2 (210, 220) 가 , .

16 4 . 4 가 . 4
 (100) 1 3 (100) , (120)가 , 1
 (210) (211) . (120)
 4 , (100) (120) 1 (210) (211)
 , (120) (121) . , 1
 , , 1
 가 , .
 , 2 5 1 . ,
 2 1 , ,
 가 .
 3 1 2 , 가
 , 가 가 .
 4 1 3 , 가 ,
 5 , 1 4 , 가 1
 1 1 가

(57)

1.
 (211, 221) 2 (210, 220) (100) ,
 (100) ,

(210, 220) (110) ;

(110) (220) (221) 1 가 (210) (211) (122) (121) (120) 2

2.

1 (110) (110) , (110) (210) (210) (212) ,

3.

1 (110) (117) 2 (212) , (110) (210) (117) (212) 가 (212) (212a) (110) (210) ,

4.

1 (110) 2 (220) , (110) (118)가 (118) (220) ,

5.

3 (220) , (110) (118)가 (118) (220) (110)

6.

1 (120) 2 (121)가 , 1 (210) (211)가 ,

7.

3 (120) , 1 (210) (211)가 , (121)가

8.

4 (120) , 1 (210) (211)가 , (121)가

9.

5 , 1 (210) (211)가 ,
 (120) (121)가

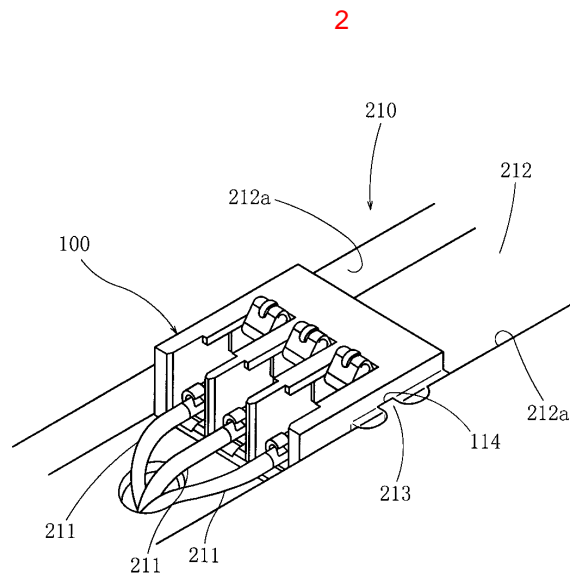
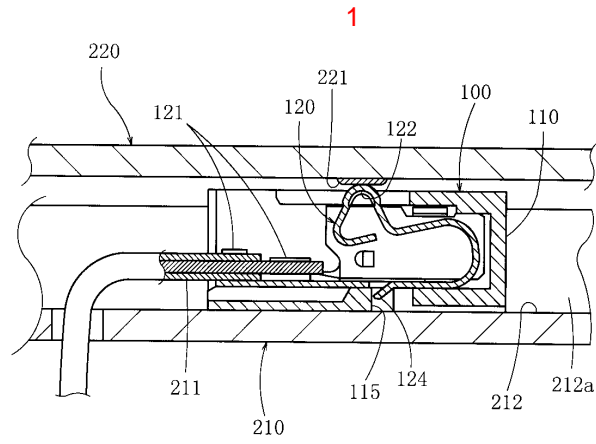

3

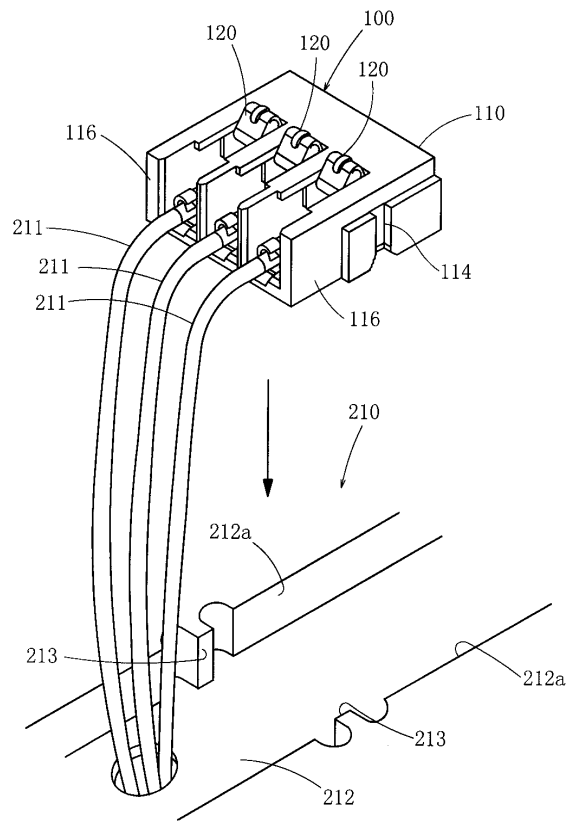

4a

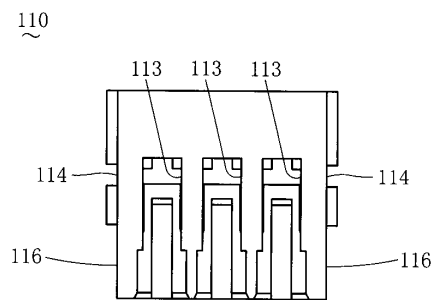

4b

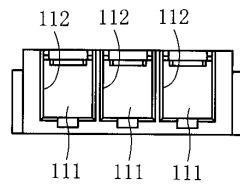

4c

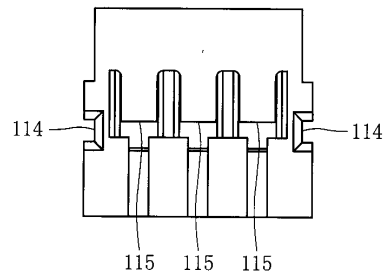

5

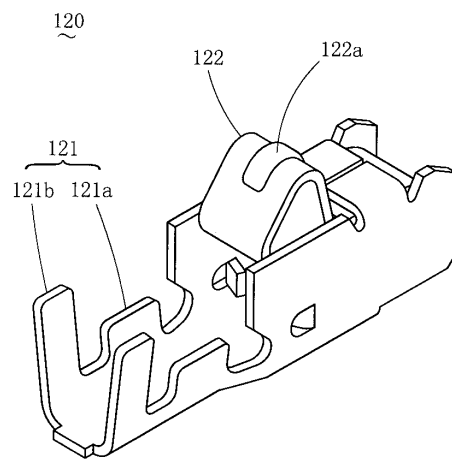

6

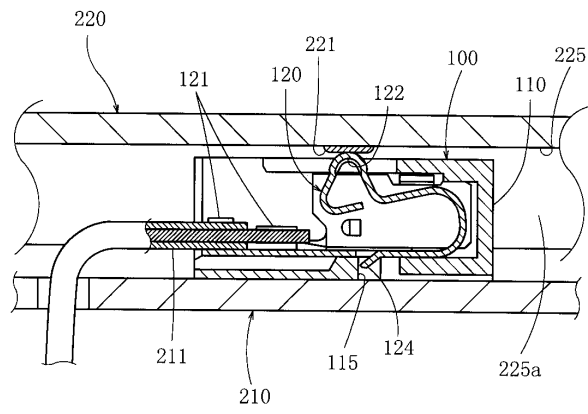

7

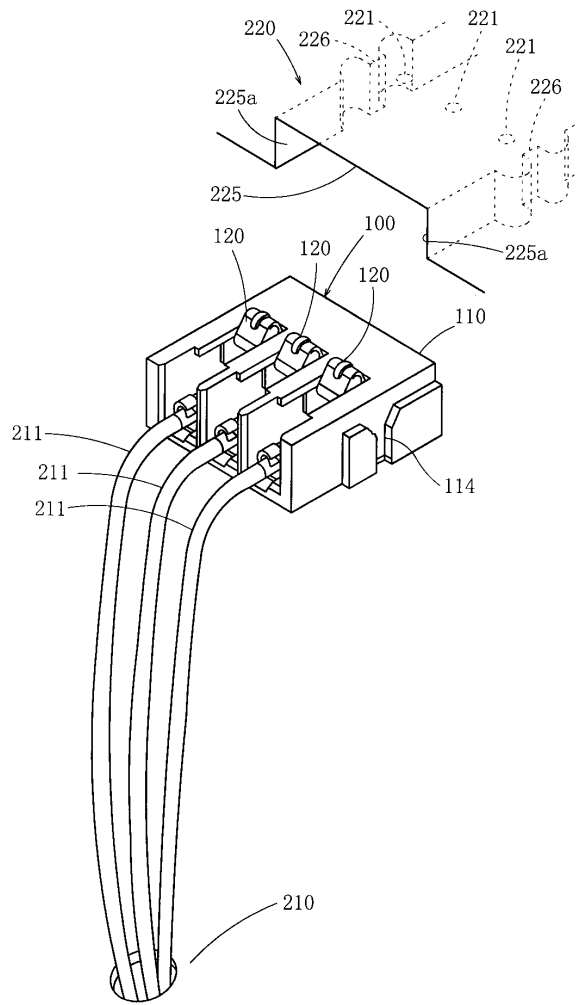

8

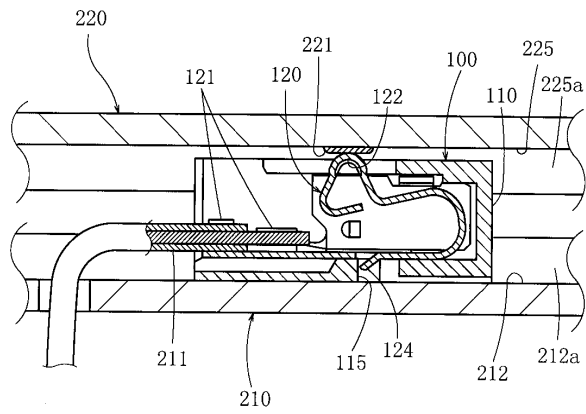

9

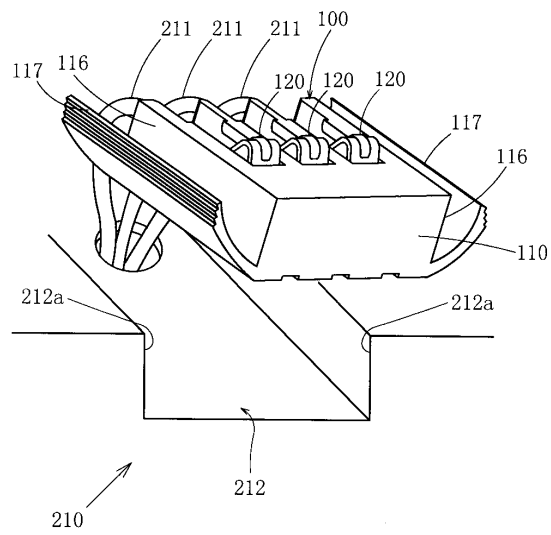

10

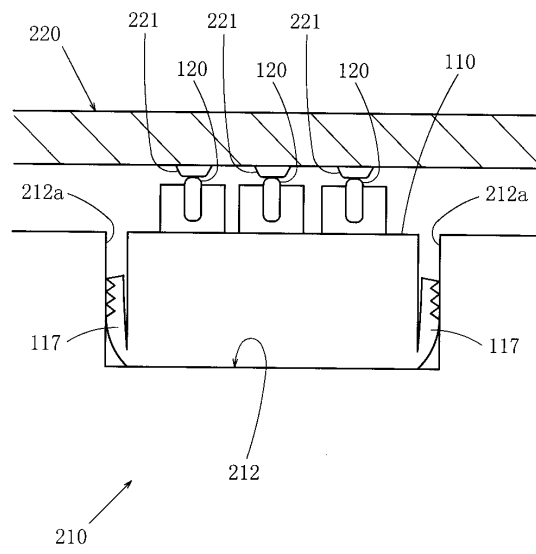

11

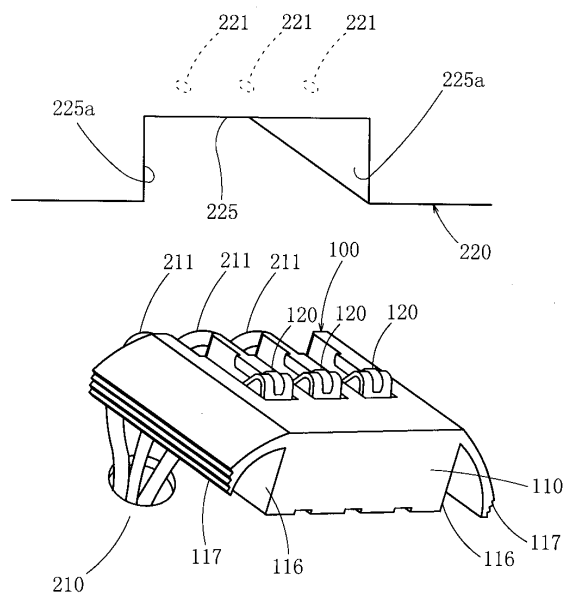

12

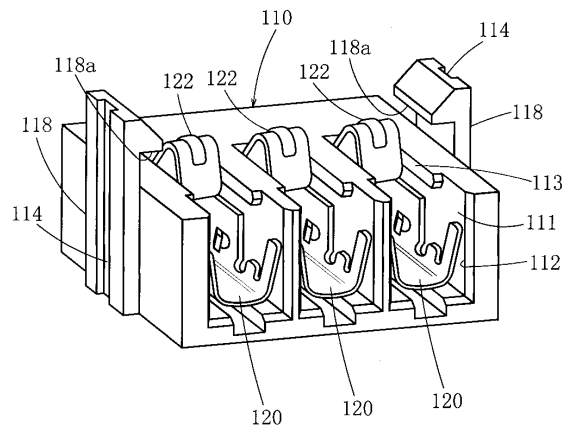

13

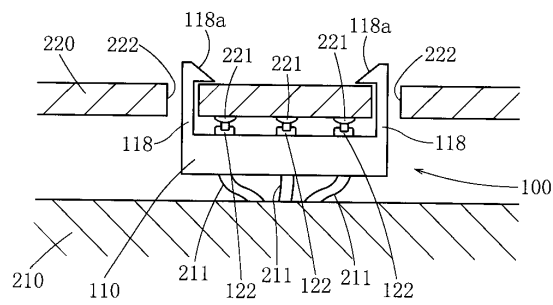

14

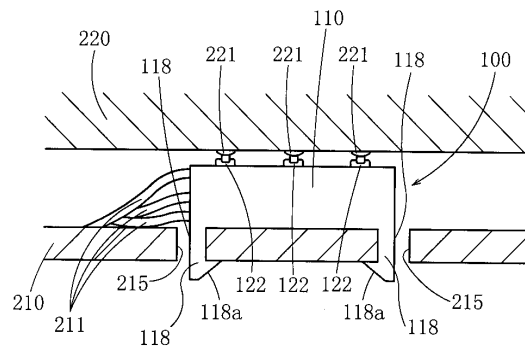

15

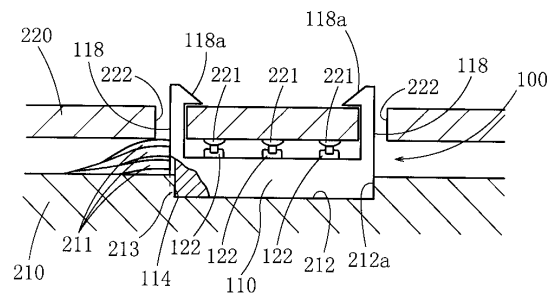

16

