

(No Model.)

2 Sheets—Sheet 1.

C. F. TELLER.

COMBINED LETTER BOX AND MAIL BAG.

No. 292,069.

Patented Jan. 15, 1884.

Fig. 1.

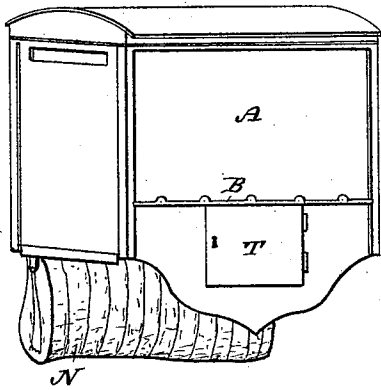

Fig. 3.

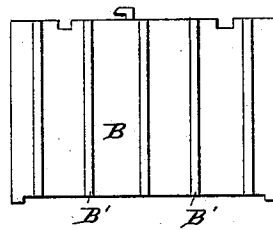

Fig. 2.

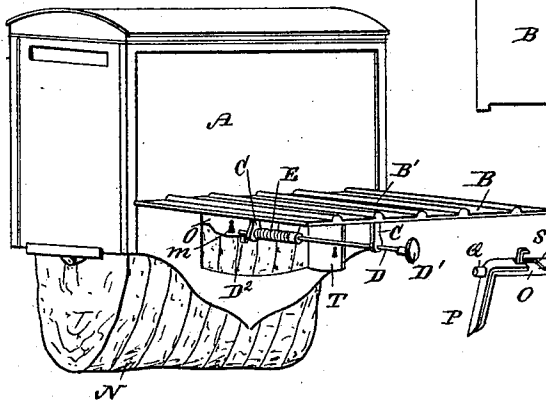
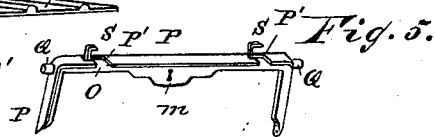
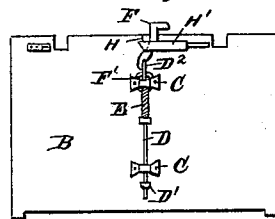

Fig. 4.



WITNESSES:

*Theo. G. Boston*  
*L. Sedgwick*

INVENTOR:

*C. F. Teller*  
 BY *Munn & Co*  
 ATTORNEYS.

(No Model.)

2 Sheets—Sheet 2.

C. F. TELLER.

COMBINED LETTER BOX AND MAIL BAG.

No. 292,069.

Patented Jan. 15, 1884.

Fig. 6.

Fig. 10.

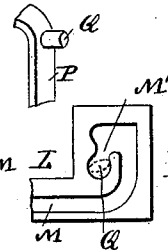
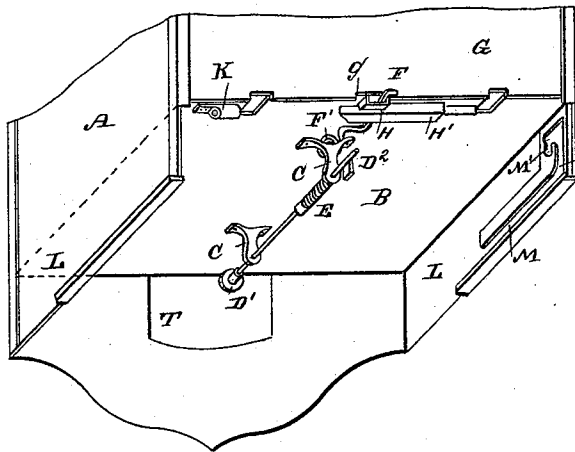

Fig. 11.

Fig. 7.

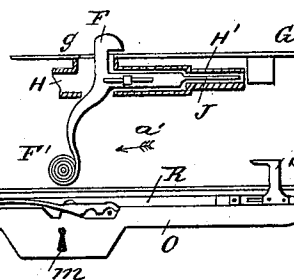

Fig. 8.

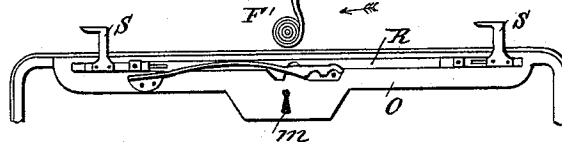
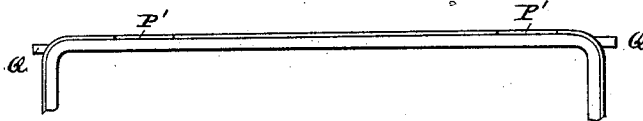

Fig. 9.



WITNESSES:

*Theo. G. Hooster*  
*Ch. Sedgwick*

INVENTOR:

*C. F. Teller*

BY

*Munn & Co*

ATTORNEYS.

# UNITED STATES PATENT OFFICE.

CARL FRIEDRICH TELLER, OF OFFENBACH-ON-THE-MAIN, GERMANY,  
ASSIGNOR TO CARL OTTO WEBER AND THEODOR MAYNZ, BOTH OF  
SAME PLACE.

## COMBINED LETTER-BOX AND MAIL-BAG.

SPECIFICATION forming part of Letters Patent No. 292,669, dated January 15, 1884.

Application filed November 13, 1883. (No model.)

*To all whom it may concern:*

Be it known that I, CARL FRIEDRICH TELLER, a subject of the Emperor of Germany, and a resident at Offenbach-on-the-main, Germany, have invented new and useful Improvements in Letter Boxes and Bags for Emptying the Same, of which the following is a specification.

My invention relates to an improved letter box and bag; and it consists in the peculiar arrangement and construction of the parts, as hereinafter more fully set forth, and pointed out in the claims.

Reference is to be had to the accompanying drawings, forming part of this specification, in which similar letters of reference indicate corresponding parts in all the figures.

Figure 1 is a perspective view of my improved letter-box and the emptying-bag held to the same, the bag and box being closed. Fig. 2 is a similar view, the box and bag being opened. Fig. 3 is a plan view of the sliding bottom. Fig. 4 is a plan view of the under side of the same. Fig. 5 is a perspective view of the bag-frame. Fig. 6 is a rear perspective view of the under side of the letter-box. Fig. 7 is a sectional plan view of the latch of the sliding bottom. Fig. 8 is a longitudinal elevation of one of the bag-frames. Fig. 9 is a longitudinal elevation of the other bag-frame. Fig. 10 is a perspective view of the end of the frame shown in Fig. 9. Fig. 11 is a longitudinal view of the inner end of the bottom part of one of the sides of the box.

The mail-box A is provided with a sliding bottom, B, adapted to be drawn through a longitudinal slot in the front of the box, which bottom is provided with transverse ribs B' on its upper surface.

From the under side of the bottom B two ears or jaws, C, project, in which a rod, D, is held to slide transversely to the front of the box and to turn, which rod has a knob, D', formed on the front end, and a key, D<sup>2</sup>, on the rear end. A spiral spring, E, surrounding and secured to the rod D, presses the same toward the front of the box.

On the under surface of the bottom B a hook, bolt, or latch, F, is pivoted at the inner edge,

which latch is acted on by a spring, F'. The bottom edge of the rear wall, G, of the box is provided with a notch, g, on the edge of which the latch F can catch. The free end of the latch F is held in a casing, H, made integral with a casing, H', in which a pin, J, is held parallel with the rear edge of the bottom, which pin J is made integral with or secured to the latch F. A loop, K, is secured to the rear edge of the bottom B, parallel with the same.

In the inner surface of that part L of each side of the box projecting below the bottom a groove, M, is formed, which is open at the front end, and is bent upward and forms a downwardly-projecting pocket or recess, M', slightly contracted at its top.

To the top of the mail-bag N two frames, O and P, are secured, which fit on each other. The frame P is provided with two notches, P', and at each end with a flat pin, Q, adapted to pass into the grooves M. The frame O is provided with a key-hole, m, and with a longitudinally-sliding bolt, R, from which two hooks, S, project upward. The front of the letter-box is provided with a small door, T, below the sliding bottom.

The operation is as follows: If the box A is to be emptied, the bag N, which is locked is passed under the bottom B in such a manner that the pins Q on the bag-frame P pass through the grooves M into the pockets M'. The door T is then opened and the rod D is pushed inward until the key D<sup>2</sup> passes into the key-hole m, and then the rod D is turned, whereby the bolt R is moved in the direction of the arrow a'. One hook, S, passes into the loop K, and the other passes into the casing H' and strikes the end of the pin J, and disengages the latch F from the edge of the notch g. If the sliding bottom is then drawn outward, the frame O is moved outward with it, and the bag is opened, as the frame P is held by the pins Q in the pockets M, the letters dropping into the bag. By drawing the frames O P apart the pins Q of the frames are brought into the position shown in Fig. 11 in the pockets, thus preventing the said pins from being removed from the pockets as long as the bag is open.

When the box A is emptied, the bottom B is pushed back into the box, the bag is closed, the rod D is turned, and thereby the key D<sup>2</sup> locks the bag and withdraws the hooks S S.

5 The latch F is released and catches on the edge of the notch g. The bag which is locked is then removed, and the door T is closed and locked.

10 Having thus described my invention, what I claim as new, and desire to secure by Letters Patent, is—

1. A letter-box provided with a sliding bottom and with a door, T, in the front and below the sliding bottom, substantially as herein shown and described.

2. A letter-box provided with a sliding bottom, on the under side of which a key-rod is held, substantially as herein shown and described.

20 3. In a letter-box, the combination, with the sliding bottom B, of the ears or jaws C, on the under side of the same, the rod D, held in the said jaws, the knob D' on the front end of the rod, the key D<sup>2</sup> on its rear end, and of the  
25 spring E, for pressing the rod in the direction

toward the front, substantially as herein shown and described.

4. In a letter-box, the combination, with the sliding bottom B, of the latch F, the pin J, connected with the same, the loop K, and the casing H', substantially as herein shown and described.

5. A bag having a frame, O, provided with a sliding bolt, R, having upwardly-projecting hooks S, substantially as herein shown and described.

6. The combination, with a letter-box provided with a sliding bottom and grooves M, terminating in pockets M', of a bag provided with a frame, P, with pins Q on its ends, and a frame, O, provided with a sliding bolt, R, having upwardly-projecting hooks S, substantially as shown and described.

In testimony whereof I have signed my name to this specification in the presence of two subscribing witnesses.

CARL FRIEDRICH TELLER.

Witnesses:

FRANZ HASSLACHER,  
JOSEPH PATRICK.