



⑫

EUROPEAN PATENT SPECIFICATION

④⑤ Date of publication of patent specification :
01.06.94 Bulletin 94/22

⑤① Int. Cl.⁵ : **B21G 3/12, B21G 3/28**

②① Application number : **90850253.7**

②② Date of filing : **26.06.90**

⑤④ **A clamping device for making nails.**

③⑩ Priority : **30.06.89 SE 8902386**

④③ Date of publication of application :
02.01.91 Bulletin 91/01

④⑤ Publication of the grant of the patent :
01.06.94 Bulletin 94/22

⑧④ Designated Contracting States :
AT CH DE DK GB LI NL

⑤⑥ References cited :
DD-A- 40 525
DE-C- 369 347
US-A- 2 550 949
TECHNISCHE RUNDSCHAU. vol. 57, no. 8, 26
February 1965, BERN CH page
37" DREHMEISSELHALTER ZUM SPANNEN
KURZER RUNDER DREHMEISSEL"

⑦③ Proprietor : **HAMEX HARDMETALLVERKTYG**
AB
P.O.Box 1117
S-581 11 Linköping (SE)

⑦② Inventor : **Hurtig, Lars**
Vretagarden
S-590 61 Vreta Kloster (SE)

⑦④ Representative : **Westerlund, Christer et al**
L.A. Groth & Co Patentbyrå AB,
P.O. Box 6107
S-102 32 Stockholm (SE)

EP 0 406 202 B1

Note : Within nine months from the publication of the mention of the grant of the European patent, any person may give notice to the European Patent Office of opposition to the European patent granted. Notice of opposition shall be filed in a written reasoned statement. It shall not be deemed to have been filed until the opposition fee has been paid (Art. 99(1) European patent convention).

Description

The present invention relates to a clamping device for nails, as described in the introductory portion of claim 1.

Prior art

Clamping devices of the above-mentioned kind are previously known. They are provided in pairs in a nail-making machine and hold the nail while a head is being formed and the nail is cut off from a metal wire. Known clamping devices comprise a die holder provided with a recess, in which a hard metal die has been mounted by soldering. The reason why the entire clamping device is not made of hard metal is the high material costs. Although the clamping parts are made of metal they wear out after some time of use, and the whole clamping device will then be discarded and replaced by a new one, since the cost of removing the die and mounting a new die in the die holder will not be less than that of replacing the whole clamping device and since the tensile properties of the die holder become impaired.

DD-A-40525 discloses a clamping device according to the preamble of the claim. The die and the hole in the die holder each have a hexagonal cross section. This design has quite a few disadvantages. One is that the corners of the hexagonal hole form indications of fraction which weaken the holder and which may cause cracks therein emanating from the corners. Another one is that the die and the hole in the die holder are more complicated to manufacture than dies and die holes having circular cross sections. A third disadvantage is that the machining, especially grinding, of the die and the die hole is more difficult and more time-consuming than that of circular dies and die holes.

The die holder of DD-A-40525 is provided with a device for axially retaining the die in the hole, the hexagonal cross-section preventing the die from rotation about its longitudinal axis, the die not being clamped in the die holder.

Description of the invention

It is an object of the present invention to improve clamping devices of the above-mentioned kind and to provide a clamping device in which the die is easily replaceable by a new die in the same die holder, and in which the die is held in the recess of the die holder without being soldered thereto and in which a plurality of clamping surfaces of the same shape, or a plurality of clamping surfaces of different shapes adapted to different nail shapes and/or dimensions, are formed on the die and can be brought into contact with the complementary clamping device of the pair of clamping devices, thereby extending the life of the die and

the field of applications and reducing the number of dies to be manufactured and kept in stock. Further, time will be saved, since it is easier to exchange the die in the existing die holder when, later on, the clamping device is mounted in the machine, than it would be to exchange the entire clamping device.

This object is accomplished by providing the clamping device according to the claim.

Description of the figures

Figure 1 is a perspective view of a clamping device according to an embodiment of the invention, seen obliquely from above and from the front,

Figure 2 is a perspective view of a die holder included in the clamping device according to Figure 1, seen obliquely from below and from the rear; Figure 3 is a perspective view of a hard-metal die included in the clamping device according to Figure 1, seen obliquely from below and from the rear, and

Figure 4 is a top plan view of two complementary clamping devices according to Figure 1.

Preferred embodiment

The clamping devices shown in the figures are used in pairs, as shown in Figure 4, in a nail-making machine to clamp a wire while a head is being formed at the open end of the wire by means of a punch and the wire is cut to the length of the nail by cutting tools working in pairs.

Each of the two clamping devices, which are of essentially the same shape, comprises a die holder 1 intended to be mounted in the nail-making machine, and a hard-metal die 2, which is detachably mounted in the die holder.

The die holder 1, which is made of steel, has a parallel-trapezoidal cross section and is provided with a recess in the form of a drilled hole 3 at one end. The circumference of the drilled hole 3 is smaller than the circumference of a circle, so that the drilled hole opens at said end along two parallel edges 4 and 5, the distance between which is considerably smaller than and preferably around two fifths of the diameter of the drilled hole. The edges 4, 5 delimit parallel surfaces 6 and 7 on the die holder 1, the parallel surfaces connecting on to bevels 8 and 9. A smaller drilled hole 10 parallel with the drilled hole 3 but of a smaller diameter than the drilled hole is connected with the drilled hole 3 by means of a through slot 11. A through hole 12 intersects the slot 11 and is provided, on one side of the slot, with a thread 13. A bolt 14 is inserted in the drilled hole 12 and presses the two tool portions 1a and 1b on both sides of the slot against each other on tightening, since said portions are flexible.

The die 2 is substantially cylindrical and has a di-

iameter which is slightly smaller than the diameter of the drilled hole 3. Its length corresponds to the length of the drilled hole 3. On its mantle surface, the die 2 is formed with three plane surfaces in which clamping surfaces in the form of clamping grooves 15 are provided. Each clamping groove comprises a semi-cylindrical portion 16 with a plurality of annular slots 17, and a semi-frustoconical portion 18. All the clamping grooves 15 can be identical or of different dimensions adapted to different nail sizes and shapes. The clamping grooves 15 can be less or more than three in number and are suitably evenly distributed over the circumference of the die.

The die 2 fits the drilled hole 3 into which it is inserted in the way shown in Figures 1 and 4 and is turnable 360° within the drilled hole. The die is lockable in any position in the drilled hole by tightening the bolt 14 which presses the portions 1a and 1b against each other.

Figure 4 shows two clamping devices, at least one of which is slidable along its longitudinal axis towards and away from the other clamping device. In the positions of the clamping devices according to Figure 4, two identical clamping surfaces 15 on the two dies 2 bearing on each other form a circular groove 19, the portions 16 of which are intended to clamp a wire (not shown) from which a nail is to be made, and the portions 18 of which are intended to guide the wire fed to the clamping devices. At the portion of each clamping surface 15 furthest away from the portion 18, a nail head is intended to be formed from the wire at the open end thereof when a punch (not shown) is struck onto said end in the longitudinal direction of the wire.

While there has been described above and shown on the drawings an embodiment of the invention, it will be appreciated that the invention is not limited to this embodiment but only by what is stated in the claim.

Claims

1. A clamping device for nails, comprising a die holder (1) mountable in a nail-making machine and a hardmetal die (2) disposed in said die holder, the die holder with the die being suitable for clamping nails in combination with a complementary die holder with die during the manufacture of the nails, the hard-metal die having a clamping surface (15) which together with a corresponding clamping surface of a complementary die holds a nail during the manufacture thereof, the die (2) being provided with at least two circumferentially spaced apart clamping surfaces (15), each clamping surface (15) running parallel to the longitudinal axis of the die (2), the die (2) being detachably inserted and lockable in a recess (3)

formed in the die holder (1) so that one of the clamping surfaces will face and cooperate with a corresponding clamping surface on the complementary die, **characterized in** that the recess (3) extends as a partially circular-cylindrical hole through the die holder (1) and is perpendicular to the longitudinal axis of the die holder (1), the hole opening along its length along two parallel edges (4,5) in the end surface of the die holder (1) facing the complementary die holder (1), the distance between the edges (4,5) being smaller than the size of the hole, the clamping surface (15) of the die (2) being able to face the corresponding clamping surface on the complementary die while being arranged between the two parallel edges (4,5) of the die holder (1), a second drilled hole (10) in the die holder (1) being provided parallel to the recess (3) on the side opposite to the position of the end surface, a through slot (11) connecting the second hole (10) with the recess (3) along its entire length in the plane of symmetry of the die holder (1), and a bolt (14) being provided in between of the recess (3) and the second hole (10) and perpendicular to the slot (11), enabling clamping of the die (2) in the die holder (1).

Patentansprüche

1. Klemmvorrichtung für Nägel, umfassend einen in einer Nagelherstellungsmaschine montierbaren Matrizenhalter (1) und eine in diesen Matrizenhalter eingesetzte Hartmetallmatrize (2), in welchem Matrizenhalter mit Matrize in Kombination mit einem komplettierenden Matrizenhalter mit Matrize während der Nagelherstellung Nägel festklemmbar sind, wobei die Hartmetallmatrize eine Klemmfläche (15) aufweist, die zusammen mit einer entsprechenden Klemmfläche einer komplettierenden Matrize einen Nagel während dessen Herstellung festhält, und wobei die Matrize (2) mit wenigstens zwei Umfangsrichtung voneinander im Abstand befindlichen Klemmflächen (15) versehen ist, von denen jede parallel zur Längsachse der Matrize (2) verläuft, sowie lösbar und verriegelbar in eine im Halter (1) ausgebildete Ausnehmung (3) eingesetzt ist, so daß eine der Klemmflächen einer entsprechenden Klemmfläche der komplettierenden Matrize gegenüberliegt und mit dieser zusammenarbeitet, dadurch gekennzeichnet, daß sich die Ausnehmung (3) als ein teilweise kreiszylindrisches Loch durch den Halter (1) erstreckt und senkrecht zur Längsachse des Matrizenhalters (1) verläuft, wobei sich das Loch in seiner Längsrichtung entlang zweier paralleler Kanten (4,5) in die dem komplettierenden Matrizenhalter (1) gegenüberlie-

gende Endfläche des Matrizenhalters (1) öffnet und der Abstand zwischen den Kanten (4, 5) kleiner ist als der Durchmesser des Loches, und wobei die Klemmfläche (15) der Matrize (2) der entsprechenden Klemmfläche der komplettierenden Matrize gegenüberstellbar ist sobald sie zwischen den beiden parallelen Kanten (4,5) des Matrizenhalters (1) positioniert ist, und wobei ferner auf der der Endfläche entgegengesetzten Seite eine zweite, parallel zur Ausnehmung (3) verlaufende Durchgangsbohrung (10) vorgesehen ist, die über einen durchgehenden Schlitz (11) entlang ihrer gesamten Länge in der Symmetrieebene des Matrizenhalters (1) mit der Ausnehmung (3) verbunden ist, wobei zwischen der Vertiefung (3) und der zweiten Bohrung (10) eine senkrecht zum Schlitz (11) verlaufende Schraube (14) zum Festklemmen der Matrize (2) im Matrizenhalter (1) vorgesehen ist.

percé dans le porte-outil (1) étant prévu parallèlement à la cavité (3) sur le côté opposé à l'emplacement de la surface d'extrémité, une fente traversante (11) étant prévue pour relier le second trou (10) à la cavité (3) sur toute sa longueur dans le plan de symétrie du porte-outil (1) et un boulon (14) étant prévu entre la cavité (3) et le second trou (10), perpendiculairement à la fente (11) pour permettre le blocage de l'outil (2) dans le porte-outil (1).

Revendications

1. Dispositif de blocage pour clous, comprenant un porte-outils (1), montable dans une machine à fabriquer des clous, et un outil (2) en métal dur disposé dans ledit porte-outil, le porte-outil avec l'outil étant susceptibles de bloquer des clous, lorsqu'ils sont en combinaison avec un porte-outil complémentaire avec outil pendant la fabrication des clous, l'outil en métal dur ayant une surface de serrage (15) qui, en association avec une surface de serrage complémentaire d'un outil complémentaire, maintient un clou pendant la fabrication de celui-ci, l'outil (2) étant muni d'au moins deux surfaces de serrage (15) espacées selon la circonférence, chaque surface de serrage (15) s'étendant parallèlement à l'axe longitudinal de l'outil (2), celui-ci étant introduit de manière amovible de façon à pouvoir être bloqué dans une cavité (3) formée dans le porte-outil (1) de telle manière que l'une des surfaces de serrage se trouve en face d'une surface de serrage correspondante sur l'outil complémentaire et coopère avec elle, caractérisé en ce que la cavité (3) s'étend sous la forme d'un trou cylindrique partiellement circulaire traversant le porte-outil (1) et est perpendiculaire à l'axe longitudinal du porte-outil (1), le trou débouchant, sur toute sa longueur, selon deux bords parallèles (4, 5) dans la surface d'extrémité du porte-outil (1), en face du porte-outil complémentaire (1), la distance entre les bords (4, 5) étant inférieure à la taille du trou, la surface de serrage (15) de l'outil (2) étant apte à faire face à la surface de serrage correspondante sur l'outil complémentaire, en étant disposée entre les deux bords parallèles (4, 5) du porte-outil (1), un second trou traversant (10)

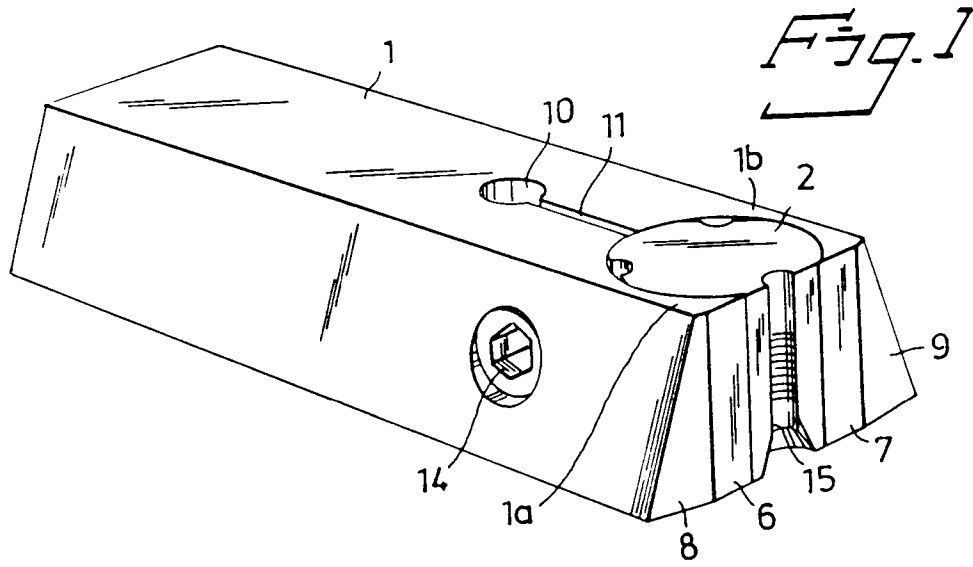
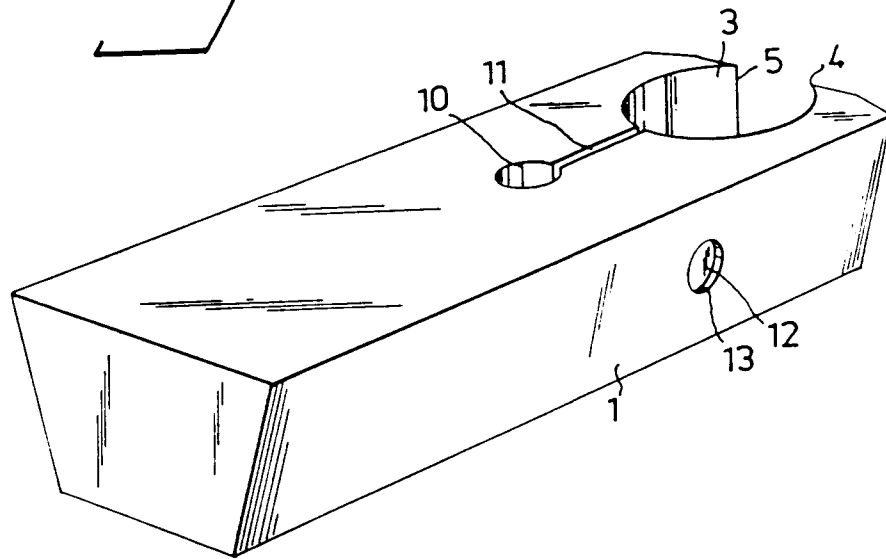

Fig. 2



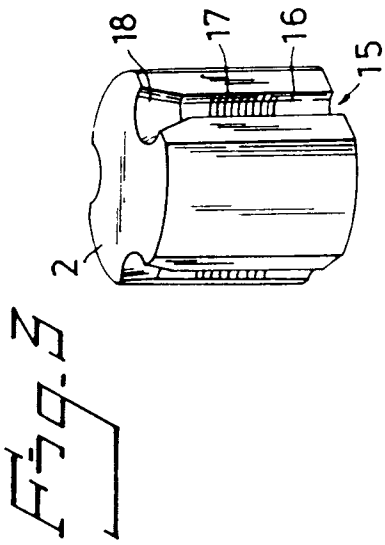

Fig. 4

