

(19)
(12)

(KR)
(Y1)

(51) 。 Int. Cl. ⁶
B60G 7/00

(45)
(11)
(24)

2001 10 25
20 - 0237454
2001 06 28

(21) 20 - 1997 - 0039106
(22) 1997 12 19

(65) 1999 - 0026568
(43) 1999 07 15

(73)

231

(72)

102 - 201

(74)

:

(54)

가 , (30) ,
(2) (32)
(34, 36) , (30b) (30a) (30c) .

4

1 가

2

3 2 A - A

4

5 (a), (b), (c) , 4 B - B, C - C, D - D

[]

2: 4:

6: 8:

30: 30a, 30b: ,

30c: 32:

34, 36: 38:

가 , ,

가 . ,

, 가 (suspension system) , ,

. 가 , 가

, 1 가 .

1 가 가 , ,

(2a) 가 가 (2) , (2)

(10) (2) (8) , (4) ,

(6) , (2) (22) (22)

(20) .

2 , (10)

(2) (12) ,

(14, 16) .

3 2 A - A , .

(10) (10a) (10b) , (10a, 10b)

가
, (off - road)

가
(F2)

2

(F1)

, 2

(P)가 가

U

가

가 가

가

가

가

4
D - D

, 5 (a), (b), (c)

, 4 B - B, C - C,

2
(32)

(30)

(2)
(34, 36)

(2 P)

(30)

(30c)

(P)

(38)

(38)

가

, 5 (a), (b), (c)
(30c)

, 4 B - B, C - C, D - D

(32)

(30)

(30a)

(30a)

(30a)

(30b)

(30b)

(30a)

(30c)

, (b)

(30)

(30b)

(30c)

(30c)

1

(30b') , 1 (30b') (30c) 2 (30b") 가 .

, (30) (30b) (38) ,

, 가

(57)

1.

가 가 (2) , (2) (8) ,
(4) , (22) 가 (22) ,
(20)

(30c) , (2) (34, 36) (32) (30b) (30a) (30)
(38) 가 가 .

2.

1 ,
(30b) (30c) 1 (30b') (30c)
2 (30b") 가 .

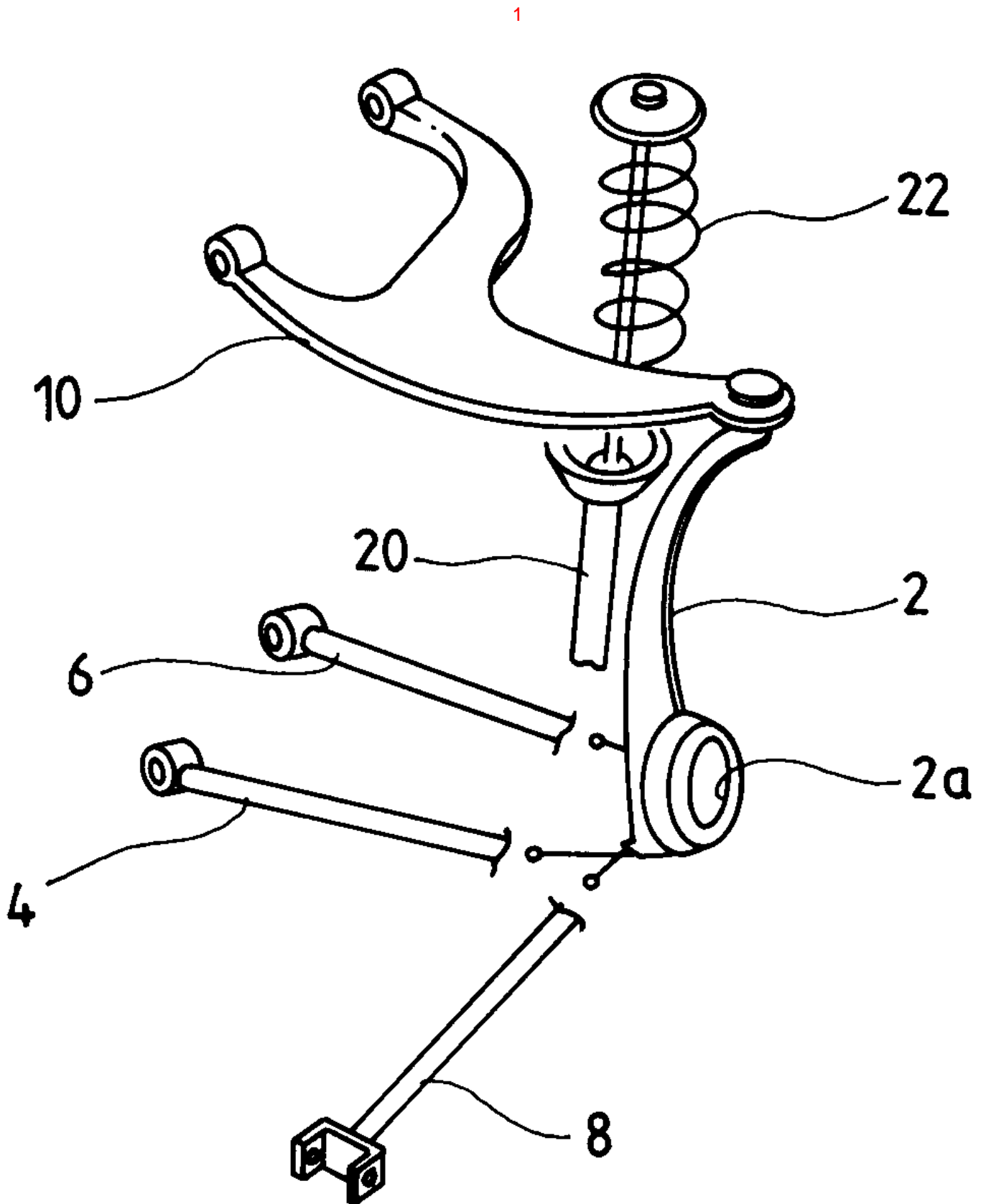

2

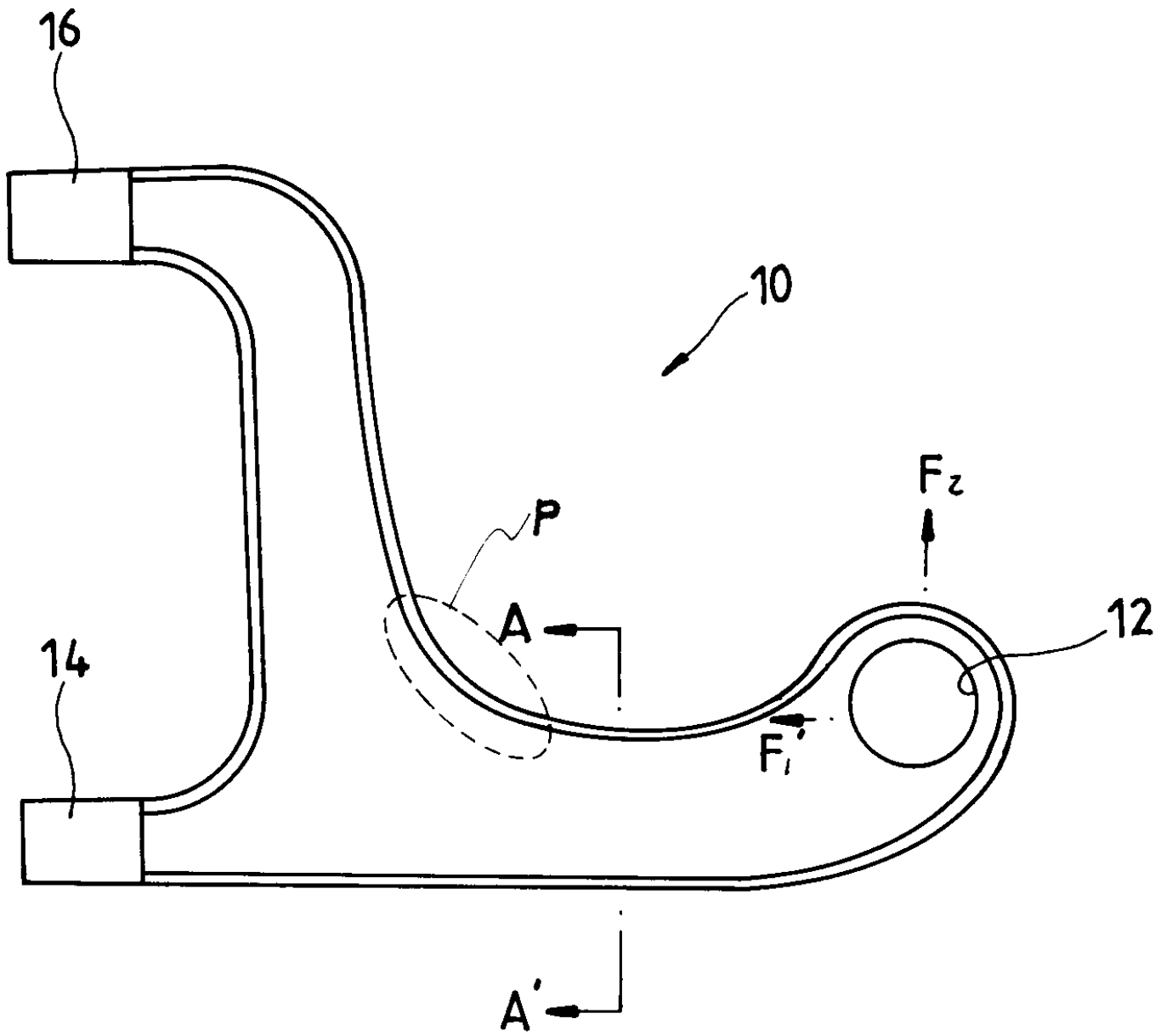

3

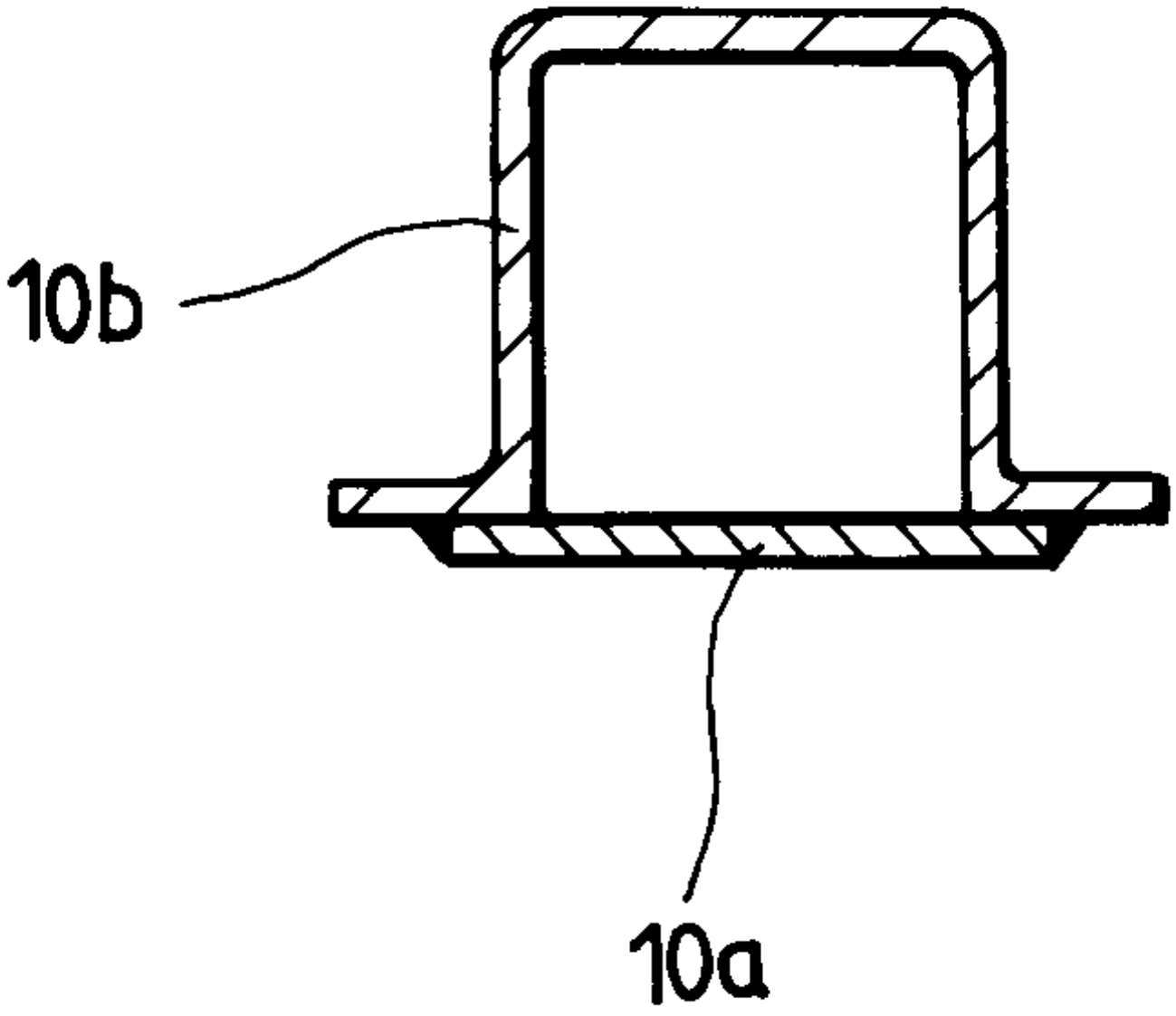

4

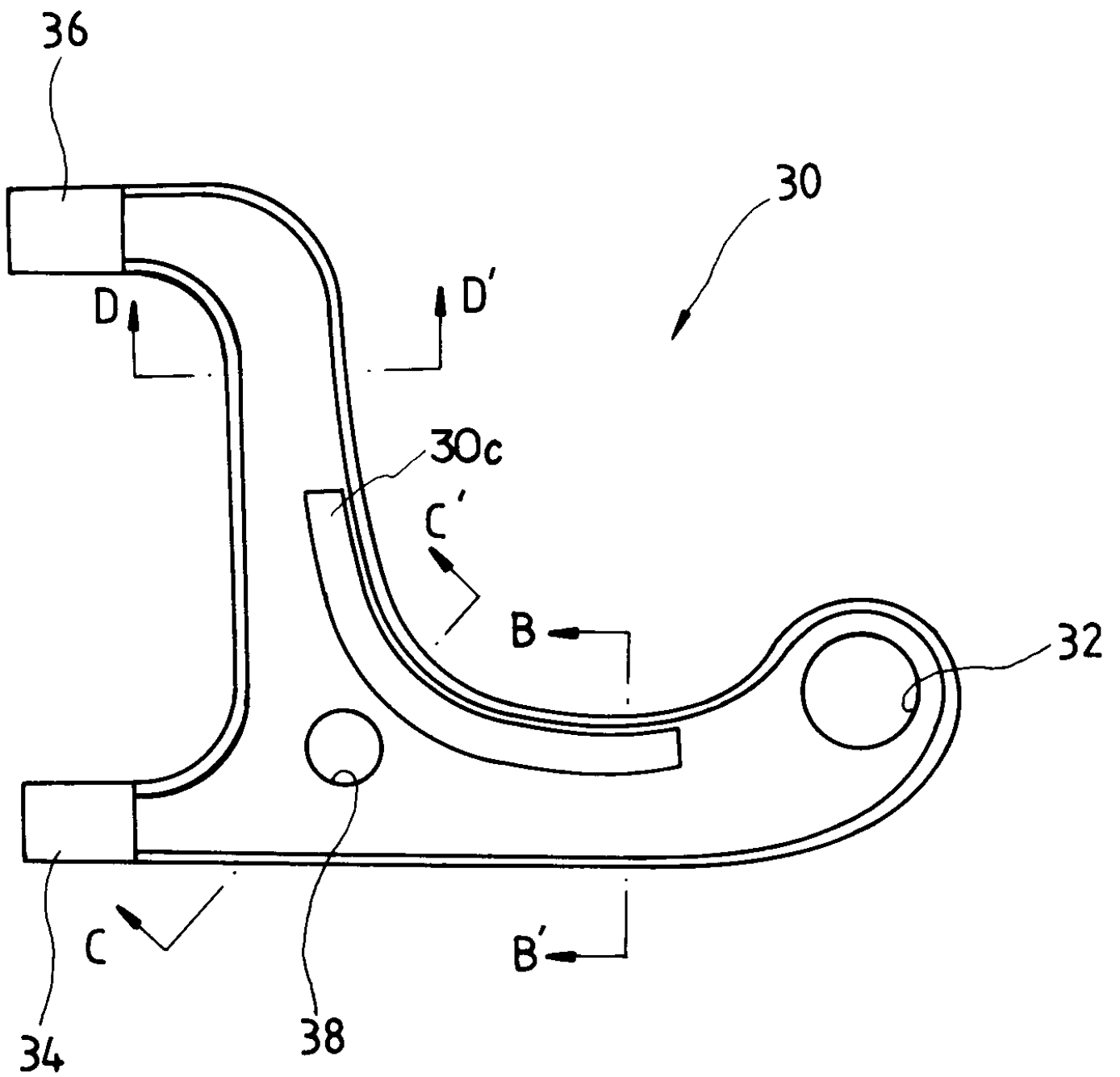

5a

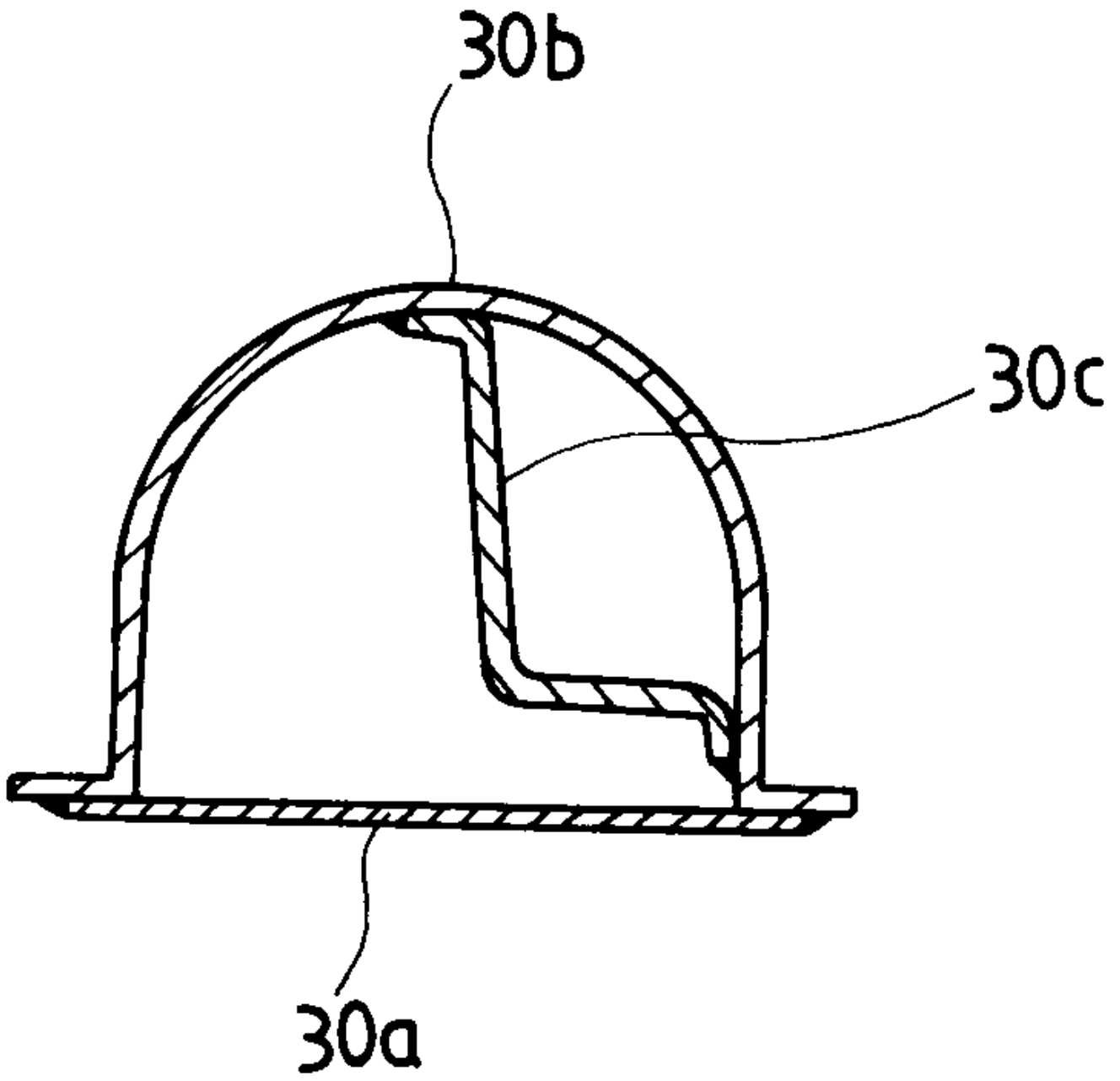

5b

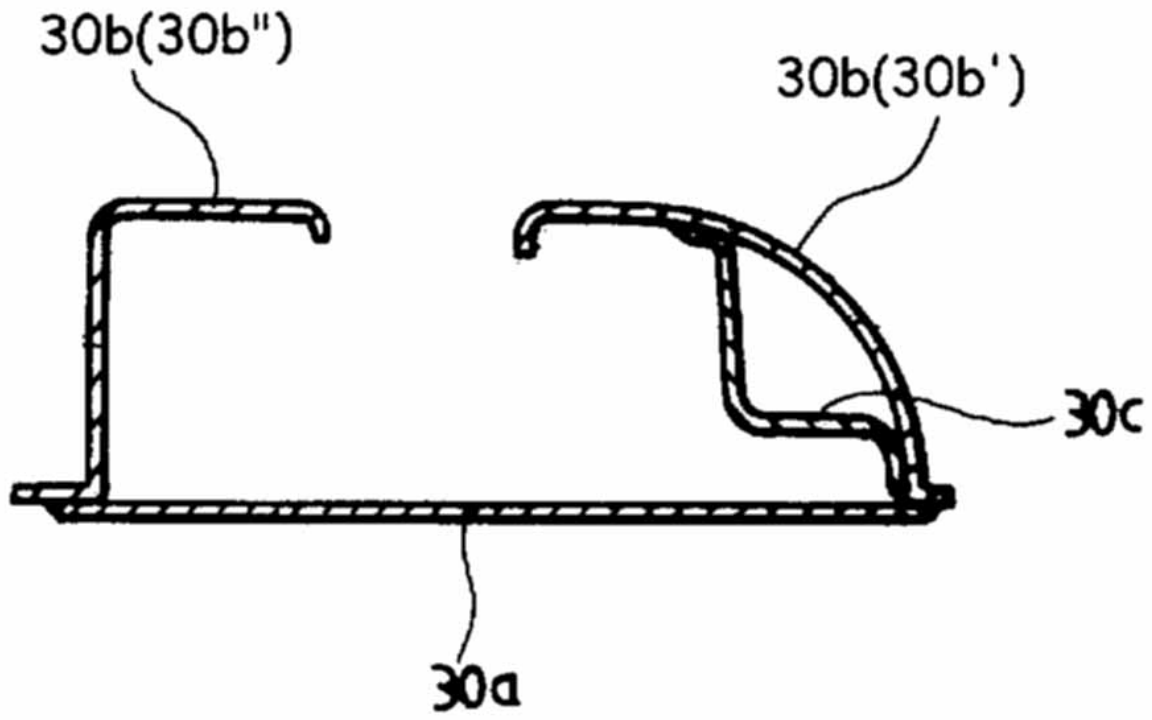

5c

