

April 22, 1958

W. G. MARSH

2,831,689

ADJUSTABLE BASKETBALL BACKBOARD SUPPORT

Filed April 27, 1956

2 Sheets-Sheet 1

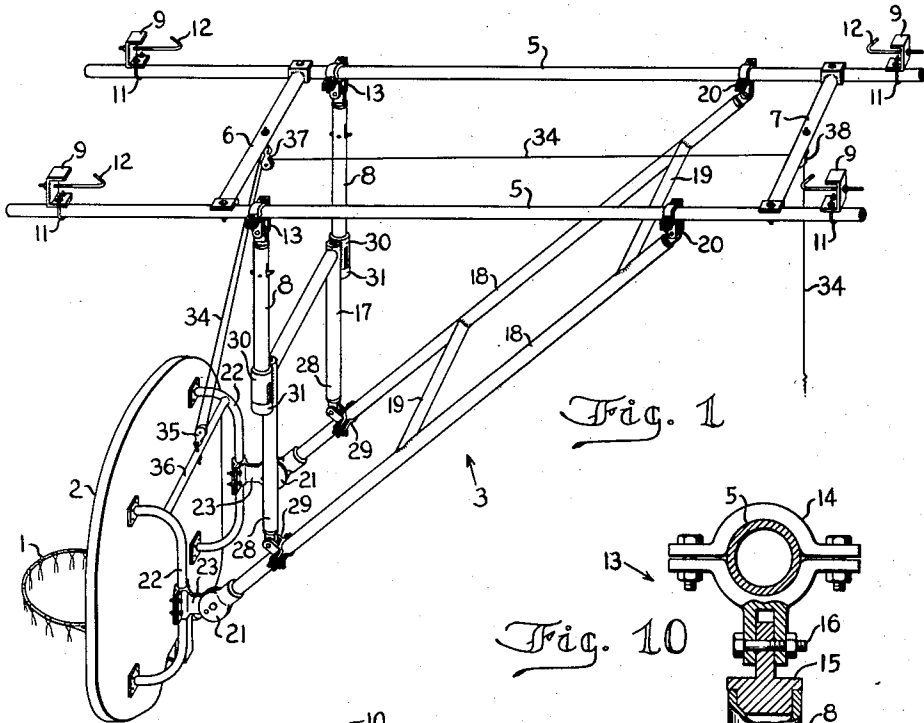

Fig. 1

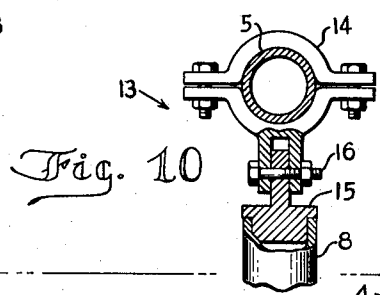

Fig. 10

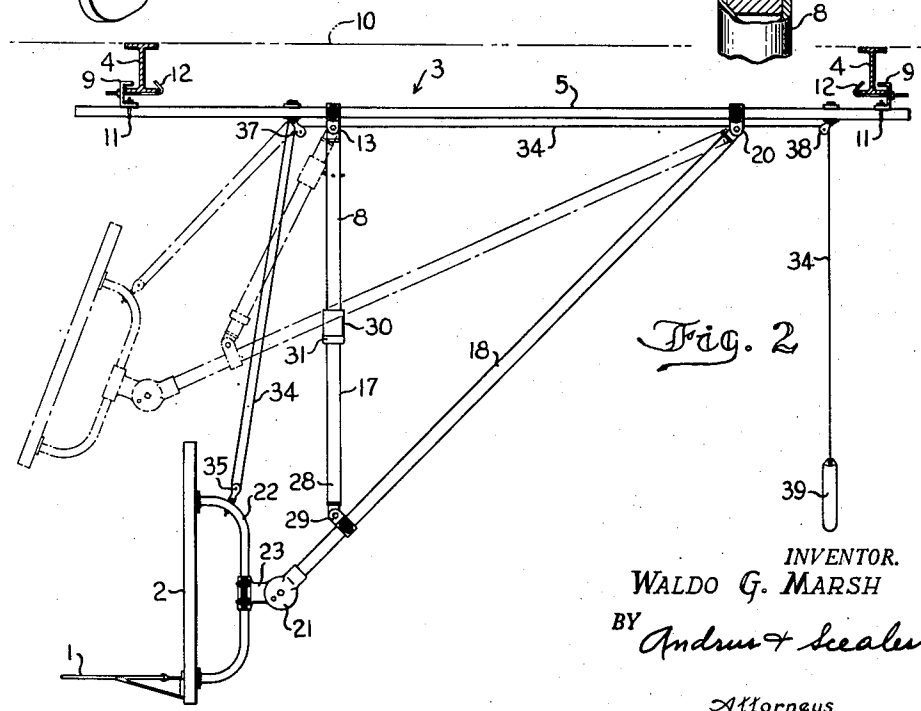

Fig. 2

INVENTOR.
WALDO G. MARSH
BY *Andrew & Sealen*

Attorneys

April 22, 1958

W. G. MARSH

2,831,689

ADJUSTABLE BASKETBALL BACKBOARD SUPPORT

Filed April 27, 1956

2 Sheets-Sheet 2

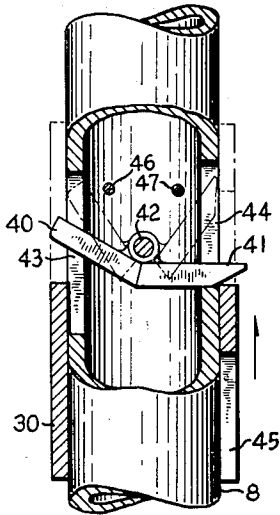

Fig. 3

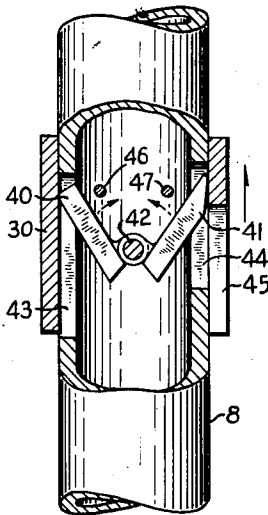

Fig. 4

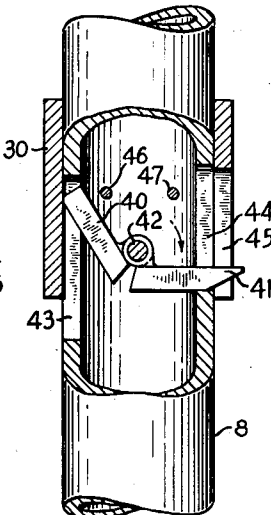

Fig. 5

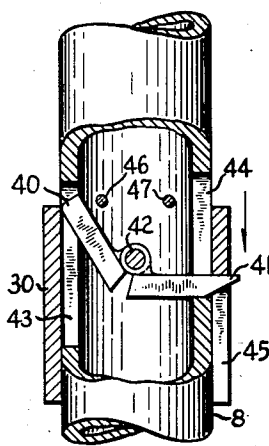

Fig. 6

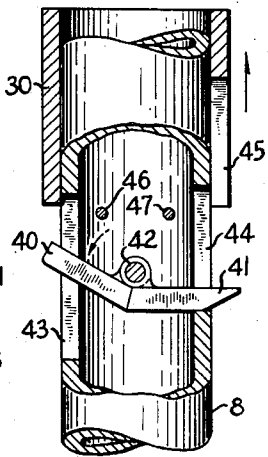

Fig. 7

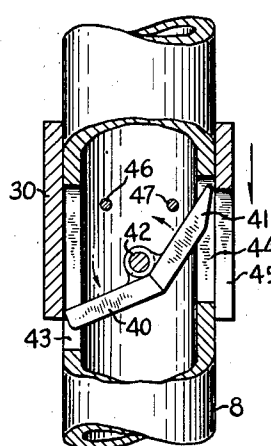

Fig. 8

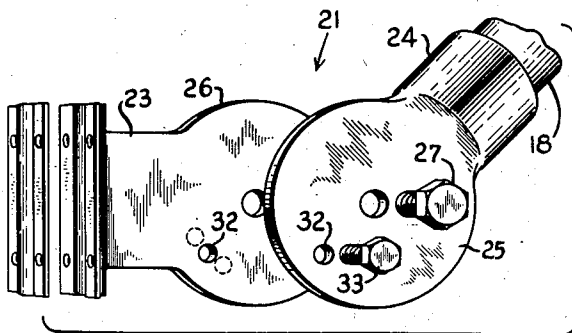

Fig. 9

INVENTOR.
WALDO G. MARSH
BY
Andrus & Seales
Attorneys

2,831,689

ADJUSTABLE BASKETBALL BACKBOARD SUPPORT

Waldo G. Marsh, Stevens Point, Wis.

Application April 27, 1956, Serial No. 581,053

8 Claims. (Cl. 273-1.5)

This invention relates to adjustable means for attaching the backboard and basket to various structural parts of buildings and for supporting the backboard and basket alternatively in the prescribed position for basketball playing or in an elevated position where the backboard and basket will not interfere with other activities or games.

An object of the invention is to provide a more rigid suspension of the backboard by means of a supporting structure which is more readily adapted to various installations.

Another object of the invention is to provide an adjustable framework which is readily secured to a series of beams or other structural parts of the gymnasium.

Another object is to provide a framework which can be secured to the structural parts of the building in various positions and which parts are variously positioned respecting each other.

Another object is to provide for the raising and lowering of the backboard from a normal playing position at a given height from the floor and to an elevated position immediately beneath the ceiling of the building.

Another object of the invention is to provide for the ease of angular adjustment of the backboard upon installation of the frame assembly in a given installation.

Another object of the invention is to provide improved means for securing the backboard in the elevated position which cannot be tampered with and which is independent of the rope and pulley means for effecting the actual elevation of the backboard.

Another object is to provide a locking means for securing the backboard in the elevated position so that the structure may be made of such rigidity and weight as which will require no securement in the lower playing position. That is, the weight of the supporting structure is sufficient to secure the backboard in the lower playing position without other latch means and the like. The latch means provided secures the backboard only in the elevated position and is peculiarly adapted to support the weight of the backboard without danger of its becoming loose or inoperative and allowing the apparatus to drop.

According to the invention, the latch cannot be released except when the entire weight of the backboard is already supported by the rope and pulley means and is in the firm grasp of the operator. The release of the latch means thus cannot be sudden or unexpected so that there is a danger of losing control of the rope.

The drawings furnished herewith illustrate the best mode of carrying out the invention as presently contemplated and set forth hereinafter.

In the drawings:

Figure 1 is a perspective view of the assembly showing the backboard in the lower, playing position;

Fig. 2 is a side elevation of the same and with the raised position of the backboard shown in dotted lines;

Fig. 3 is an enlarged sectional view of parts of the backboard support showing the latch means prior to engagement upon raising of the backboard;

Figs. 4 and 5 are enlarged sectional views of the latch means shown in the first and second steps of engagement;

Fig. 6 is a view similar to Figs. 3-5 showing the latch

means in engagement as it would support the backboard in the raised position;

Fig. 7 is a view similar to Fig. 4 showing the latch means in the first position for disengagement;

Fig. 8 is a view similar to Fig. 5 showing the disengagement of the latch which allows the backboard to be lowered to the playing position;

Fig. 9 is an enlarged detail view of the means for angular adjustment of the backboard upon initial installation of the apparatus; and

Fig. 10 is a detailed view of one of the hinge-connectors of the backboard support.

According to the invention, the support of basket 1 and the backboard 2 carrying basket 1 is provided by the frame assembly 3 adapted to be secured to the overhead or ceiling I-beams 4 as shown in Fig. 2. Frame assembly 3 includes the tubular, parallel longitudinal members 5 which are joined and spaced by the cross-members 6 and 7 and the vertical tubular arms 8 depending from members 5.

Members 5 are adapted to be secured at adjacent points by means of the hangers 9 at right angles to the underside of the two I-beams 4 which support the ceiling 10 of the building. Each hanger 9 is secured to the respective longitudinal member 5 by a U-bolt 11 and hangs on a lower edge of the respective beam. A hook-bolt 12 associated with each hanger 9 and extending beneath the respective beam engages the opposite edge of the beam to secure the hanger in place.

Each arm 8 is pivotally supported from the respective longitudinal frame member 5 by a connector 13 which comprises a clamp 14 fixed to member 5 and a plug 15 in which the upper end of arm 8 is fixed. The clamp 14 and plug 15 of each connector 13 are joined by a cross-pin 16 which allows limited pivotal movement of the arm 8 supported thereby.

The support of the backboard 2 and basket 1 from frame assembly 3 is provided by the U-shaped frame 17 and the two parallel braces 18 which latter are spaced and rigidly joined by the cross members 19. One end of each brace 18 is secured to a corresponding member 5 of frame assembly 1 by a connector 20 similar to connectors 13 and the opposite ends of braces 18 are connected by the adjustable fixtures 21 to the corresponding brackets 22 fixed to the rear of backboard 2. Each fixture 21 comprises a clamp member 23 which is fixed to the respective bracket 22 and a socket member 24 in which the lower end of the respective brace 18 is fixed. Members 23 and 24 include complementary disc portions 25 and 26 respectively having central holes in registry to receive the bolt 27 extending therethrough and joining members 23 and 24.

The lower ends of the side arms 28 of U-frame 17 are joined to braces 18 near fixtures 21 by the connectors 29 which are similar to connectors 13 and allow relative pivotal movement of frame 17 respecting braces 18. Arms 28 include the sleeves 30 which are fixed to the sides thereof and are open at both ends to receive and move upwardly and downwardly on arms 8 of frame assembly 3. In the lower position of basket 1 and backboard 2, sleeves 30 are supported directly on the caps 31 provided on the lower ends of arms 8.

In the installation of the assembly, the hangers 9 are adjusted and spaced on members 5 to fit the I-beams 4 and frame assembly 3 is then fixed to the beams as described so that the backboard is properly positioned respecting the cross-wise dimensions of the playing area. The hinge-connectors 13 and 20 are then located on members 5 of frame assembly 3 so that the backboard will be properly positioned with respect to the direction of the court.

By loosening bolts 27 which allows relative rotation of the parts comprising fixtures 21, the backboard 2 is then adjusted to the vertical position. Upon such adjustment and retightening of bolts 27 and after installation is completed it is recommended that a second hole 32 be drilled through the complementary discs 25 and 26 of the fixtures to receive the bolt 33 which then provides the permanent angular adjustment of the backboard. The movement of backboard 2 either upwardly or downwardly to locate the basket 1 the correct height from the floor, not shown, is allowed by loosening clamps 23 of fixtures 21 and upon retightening completes the installation of the assembly.

The pivotal movement provided by connectors 20 allows the backboard 2 to be raised in an arc while connectors 13 and 29 allow the sliding movement of sleeves 30 on arms 8. Various block and tackle arrangements may be provided for lifting the backboard including that shown in the drawings wherein the fixed end of the rope 34 is secured to cross-member 6 of frame assembly 3 and extends through pulley 35 carried by the cross-member 36 joining brackets 22 and the pulleys 37 and 38 carried by cross-members 6, and 7, respectively, of frame 1 so that the free end of the rope which may be fitted with the weight 39 located near the wall of the building, not shown.

According to the invention, the rope 34 is employed only for lifting and lowering backboard 2 but is not relied on in any way for the securement of the backboard in either the raised or lowered position. In the lowered position the weight of the backboard and supporting structure is carried by caps 31 fixed to the lower ends of arms 8. In the raised position the latch device shown more particularly in Figs. 3 through 8 is employed. In raising the backboard by means of rope 34, the sleeves 30 move upwardly to engage the pawls 40 and 41 fitted within the respective arms.

The operation of the latch means in arms 8 are identical and will be described hereinafter by reference to the latch means of only one of the arms 8. The pawls 40 and 41 are pivotally mounted in arm 8 on the cross-pin 42 extending through the arm and the pawls extend in opposite directions of pin 42 through the slots 43 and 44 formed in the arm. Slot 43 is dimensioned to receive the free end of pawl 40 with pivotal movement of the pawl in either direction so that sleeve 30 may pass thereover in either direction. The lower dimension of slot 44 is located so that pawl 41 is normally supported in a generally horizontal position with the free end thereof projecting from arm 8 in the opposite direction of the free end of pawl 40. Slot 44 allows the free end of pawl 41 to move into the arm with upward pivotal movement of the pawl so that sleeve 30 may pass thereover in the upward direction. The ends of the pawls 40 and 41 mounted on pin 42 engage each other so that the downward movement of the free end of pawl 40 causes the upward movement of the free end of pawl 41. As backboard 2 is raised by pulling rope 34 the upper end of sleeve 30 engages and lifts the projecting ends of pawls 40 and 41 and moves them into the respective slots as the sleeve moves further upward. The slot 45 extending upwardly from the lower end of sleeve 30 is located so that pawl 41 will drop by its own weight with the free end again projecting through slot 44 and also through slot 45. The backboard may then be lowered slightly so that sleeve 30 rests on pawl 41. With both sleeves 30 resting on pawls 41, the backboard is secured in the raised position, as may be observed by the person pulling the rope. The projecting end of pawls 41 indicate that the structure supporting backboard 2 is secure and that the rope may be released and need not be tied.

Both arms 8 are fitted with the latch mechanisms described and both pawls 41 should project in the same direction so as to be visible to the person manipulating the rope.

Pawls 40 and 41 must be located a minimum distance below the upper end of each arm 8 to allow the required overtravel of sleeve 30 on the arm for disengagement of pawl 41. Such disengagement is provided by the pawl 40. In the locked position of pawl 41, pawl 40 is disposed with its free end raised in slot 43 and resting against the inside of sleeve 30. By raising backboard 2 as with rope 34, sleeve 30 is moved upwardly until it is clear of pawls 40 and 41 so that they by their own balanced weight assume a generally horizontal position and project from slots 43 and 44 beneath the sleeve.

As backboard 2 is then lowered, the lower end of sleeve 30 engages the free projecting end of pawl 40 and pushes the same downwardly and into the lower portion of slot 43. The rotating of pawl 40 on pin 42 effects a corresponding rotation of pawl 41 so that its free end is raised and moved into the upper portion of slot 44 and clear of the portion of sleeve 30 above slot 45 so that the sleeve is free to pass over the pawl. The pins 46 and 47 located adjacent to the upper ends of slots 43 and 44 prevent overtravel of pawls 40 and 41 on pin 42.

The upward and downward movement of both sleeves 30 is effected simultaneously by the rope and the weight of the backboard 2 and the moving parts supporting the same is entirely carried by the rope at all times.

The entire assembly is easily adjusted at the site for permanent installation. The lateral rigidity and weight of the supporting structure is such that no locking means is required for the lower, playing position. The latch means assures the securement of the structure in the raised position and cannot be accidentally released.

Various modes of carrying out the invention are contemplated as within the scope of the following claims particularly pointing out and distinctly claiming the subject matter which is regarded as the invention.

I claim:

1. A support for a basketball backboard comprising a pair of braces having lower ends connected to the rear side of the backboard and opposite ends pivotally supported whereby the backboard is adapted to be raised and lowered in an arc as by pulley means or the like, extensible supports connected at one end to the respective braces and having the other end pivotally connected to a fixed support and having a given extended length determining the lower playing position of the backboard, each of said supports comprising an upper supporting arm and a lower arm pivotally connected to the corresponding brace, said arms being relatively movable upon lifting and lowering of the backboard, a latch connected to each upper arm and having an operative position wherein the latch is engageable with the corresponding lower arm to secure the supports at a given shortened length to maintain the upper position of the backboard, a latch operating member connected to each upper arm of each of said supports and normally disposed to allow lifting of the backboard without interference beyond said upper position with corresponding upward movement of said lower arm and having an operative position wherein the said second latch is engageable by the lower arm and movable therewith upon lowering of the backboard to said upper position, said latch operating member being operatively connected to the corresponding first latch whereby said movement of the second latch effects withdrawal of the first latch allowing the lowering of the backboard from said upper position to the playing position, and means for mounting the latch operating member with relation to said latch whereby their weight will restore the same to their operative positions.

2. A support for a basketball backboard to be secured to the parallel beams of a ceiling which support comprises a spaced pair of longitudinal members having bracket means adjustable on and lengthwise of said members and adapted to engage such beams to secure the members at a selected location across the undersides of said beams, a pair of braces having ends rigidly connected

5

to the rear side of the backboard and opposite ends pivotally connected at a selected location to the corresponding members whereby the backboard can be properly located with respect to the playing court and upon installation is adapted to be raised and lowered in an arc as by pulley means or the like, extensible supports connecting the respective members and braces and having a given extended length determining the lower playing position of the backboard, each of said supports comprising an upper arm pivotally connected to a corresponding member and a lower arm pivotally connected to the corresponding brace, said arms being relatively movable upon lifting and lowering of the backboard, and latch means connected to each support for securing the supports at a given shortened length to maintain the upper position of the backboard, said means including release means actuated by the weight thereof for releasing said latch means and allowing the lowering of the backboard to the playing position.

3. A support for a basketball backboard adapted to be secured to the parallel beams of a ceiling, comprising a spaced pair of longitudinal members having bracket means adjustable on and lengthwise of said members and adapted to engage such beams to secure the members across the undersides of said beams, a pair of braces having ends connected to the rear side of the backboard and opposite ends pivotally connected to the corresponding members whereby the backboard is adapted to be raised and lowered in an arc as by pulley means or the like, extensible supports connecting the respective members and braces and having a given extended length determining the lower playing position of the backboard, each of said supports comprising an upper arm pivotally connected to a corresponding member and a lower arm pivotally connected to the corresponding brace, said arms being relatively movable in lengthwise relation upon lifting and lowering of the backboard, a latch connected to each upper arm and engageable with the corresponding lower arm to secure the supports at a given shortened length to maintain the upper position of the backboard, a latch operating member connected to each upper arm of each of said supports and normally disposed to allow lifting of the backboard without interference beyond said upper position with corresponding upward movement of said lower arm and to be engaged by the lower arm and movable therewith upon re-lowering of the backboard, said latch operating member being operatively connected to the corresponding first latch whereby said movement of the second latch effects withdrawal of the first latch allowing the lowering of the backboard to the playing position, and means for mounting the latch operating member with relation to said latch whereby their weight will restore the same to their operative positions.

4. In a support for a basketball backboard adapted to be secured to the parallel beams of a ceiling and including a spaced pair of longitudinal members having bracket means adjustable on and lengthwise of said members and adapted to engage such beams to secure the members across the undersides of said beams, a pair of braces having ends connected to the rear side of the backboard and opposite ends pivotally connected to the corresponding members whereby the backboard is adapted to be raised and lowered in an arc as by pulley means or the like, and extensible supports connecting the respective members and braces and having a given extended length determining the lower playing position of the backboard, each of said supports comprising an upper arm pivotally connected to a corresponding member and a lower arm pivotally connected to the corresponding brace, said arms being relatively movable upon lifting and lowering of the backboard; latch means connected to each support for securing the supports at a given shortened length to maintain the upper position of the backboard, a latch operating member connected to each support and allowing lifting of the backboard beyond said upper position with corre-

6

sponding upward movement of said lower arm and subject to movement by relative movement of the corresponding arms upon re-lowering of the backboard, said latch operating member being operatively connected to the first latch means whereby said movement of the latch operating member effects withdrawal of the first latch means allowing the lowering of the backboard to the playing position, and means for mounting the latch operating member with respect to said latch whereby their weight will restore the same to their operative positions.

5. A support for a basketball backboard to be secured to the parallel beams of a ceiling which support comprises a pair of longitudinal members having means adjustable on and lengthwise of said members and adapted to engage such beams to secure the members at a selected location across the undersides of said beams, brackets fixed to the rear side of the backboard, a pair of braces having corresponding ends connected to said brackets and opposite ends pivotally connected to the corresponding members, said members being adjustably secured to said beams and said braces being adjustably secured to said brackets and said members whereby the backboard can be properly located with respect to the playing court and upon installation is adapted to be raised and lowered in an arc as by pulley means or the like, extensible supports connecting the respective members and braces and having a given extended length determining the lower playing position of the backboard, each of said supports comprising an upper arm pivotally connected to a corresponding member and a lower arm pivotally connected to the corresponding brace, said arms being relatively movable upon lifting and lowering of the backboard, and a latch means associated with each support securing the supports at a given shortened length to maintain the upper position of the backboard, said means including release means actuated by the weight thereof for releasing said latch means and allowing the lowering of the backboard to the playing position.

6. The structure of claim 5 which further includes means connecting said brackets and the respective braces for angularly and vertically adjusting the backboard with respect to the floor.

7. In a support for a basketball backboard, a pair of longitudinal members, brackets fixed to the rear side of the backboard, a pair of braces having corresponding ends rigidly connected to said brackets and opposite ends pivotally connected to the corresponding members, said braces being adjustably secured to said brackets and said members whereby the backboard can be properly located with respect to the playing court and upon installation is adapted to be raised and lowered in an arc as by pulley means or the like, extensible supports connecting the respective members and braces and having a given extended length determining the lower playing position of the backboard, each of said supports comprising an upper arm pivotally connected to a corresponding member and a lower arm pivotally connected to the corresponding brace, said arms being relatively movable upon lifting and lowering of the backboard, and latch means connected to each support for securing the supports at a given shortened length to maintain the upper position of the backboard, said means including release means actuated by the weight thereof for releasing said latch means and allowed the lowering of the backboard to the playing position.

8. The structure of claim 7 which further includes means connecting said brackets and the respective braces for angularly and vertically adjusting the backboard with respect to the floor.

References Cited in the file of this patent

UNITED STATES PATENTS

2,219,528	Osness	Oct. 29, 1940
2,712,445	Barclay et al.	July 5, 1955
2,741,930	Montooth et al.	Apr. 17, 1956