



(19) **United States**

(12) **Patent Application Publication**  
**Proch**

(10) **Pub. No.: US 2004/0262417 A1**

(43) **Pub. Date: Dec. 30, 2004**

(54) **RECIRCULATING WATER FOUNTAIN**

(57) **ABSTRACT**

(76) **Inventor: Nathan Proch, Los Angeles, CA (US)**

Correspondence Address:  
**ARTHUR FREILICH**  
**9045 CORBIN AVE, #260**  
**NORTHRIDGE, CA 91324-3343 (US)**

A recirculating water fountain configured for table/desk top use comprises a water reservoir, a plenum mounted above the reservoir and configured to accumulate a substantially still pool of water, and a pump operable to pump water upwardly from the reservoir to form the water pool in the plenum. The recirculating water fountain includes a visually open flow pathway sloping downward from beneath the plenum to receive water from a plenum overflow for return to the reservoir, and a controller for alternately defining a pump-on mode and a pump-off mode. The pump controller functions to define the pump-off mode in response to the water level in the reservoir falling below a first height mark and to prevent resumption of the pump-on mode until the water level in the reservoir exceeds a second height mark. The open flow pathway includes a first portion defining convex and concave surfaces which guide the sheet flow along a visually pleasing generally sinuous path, and a second downwardly sloping diverging ramp portion which is ridged to produce a visually pleasing rippling effect.

(21) **Appl. No.: 10/609,166**

(22) **Filed: Jun. 27, 2003**

**Publication Classification**

(51) **Int. Cl.<sup>7</sup> ..... E03B 9/20**

(52) **U.S. Cl. .... 239/20; 239/16; 239/17; 239/18;**  
**239/23**

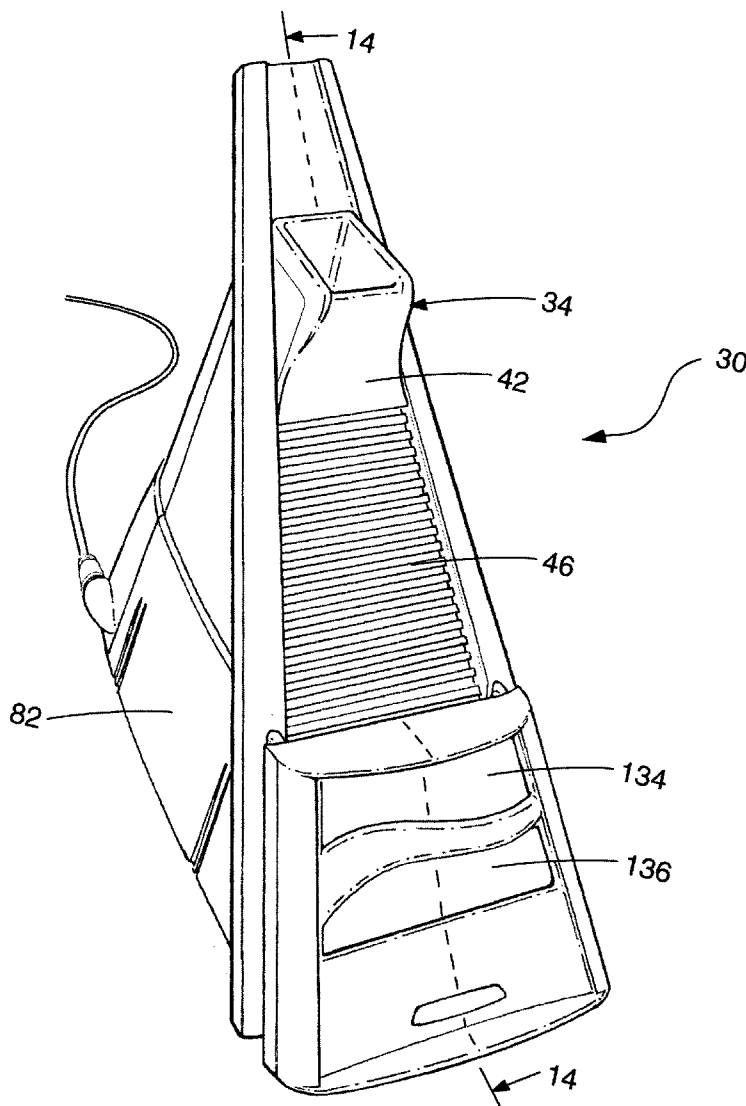

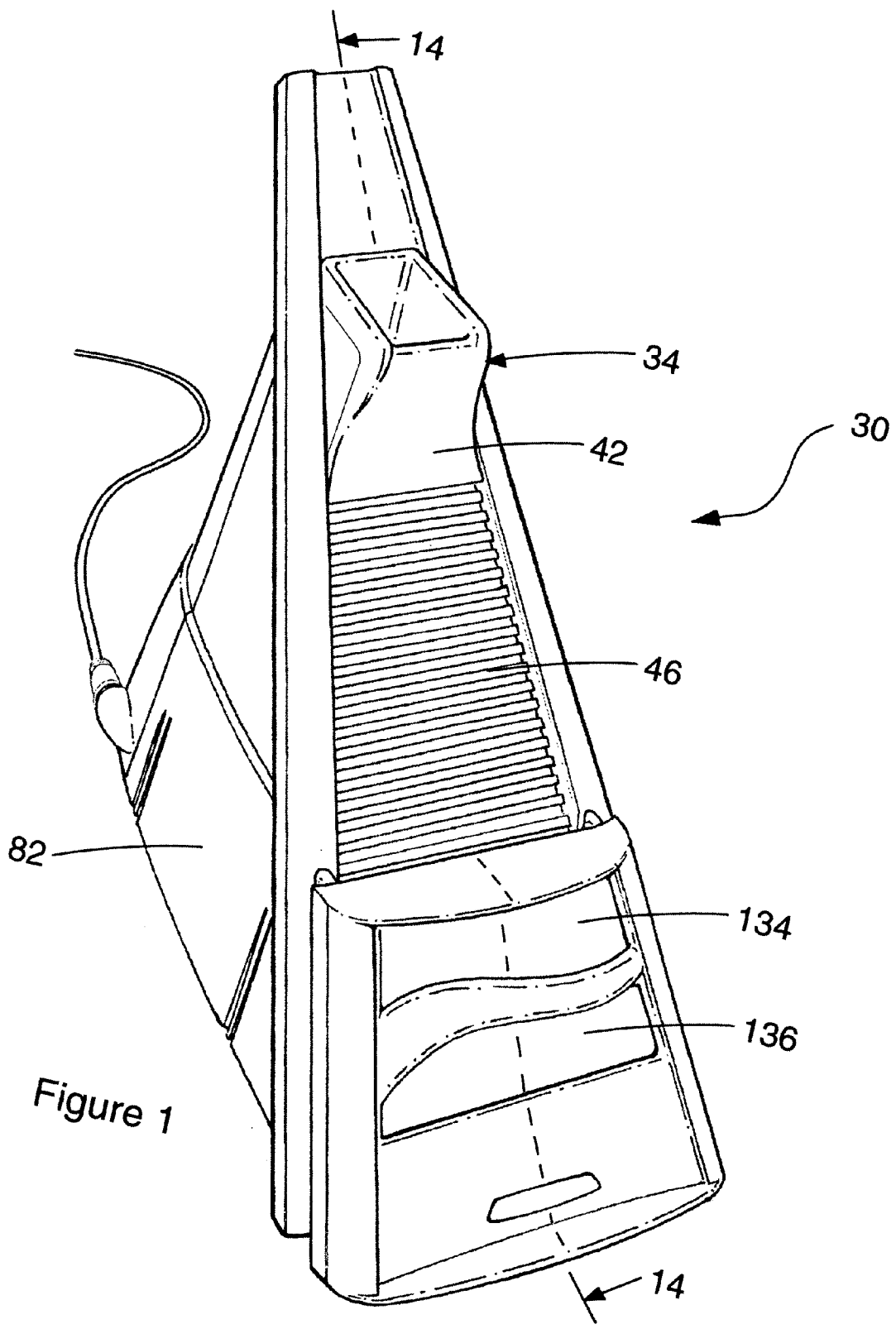

Figure 1

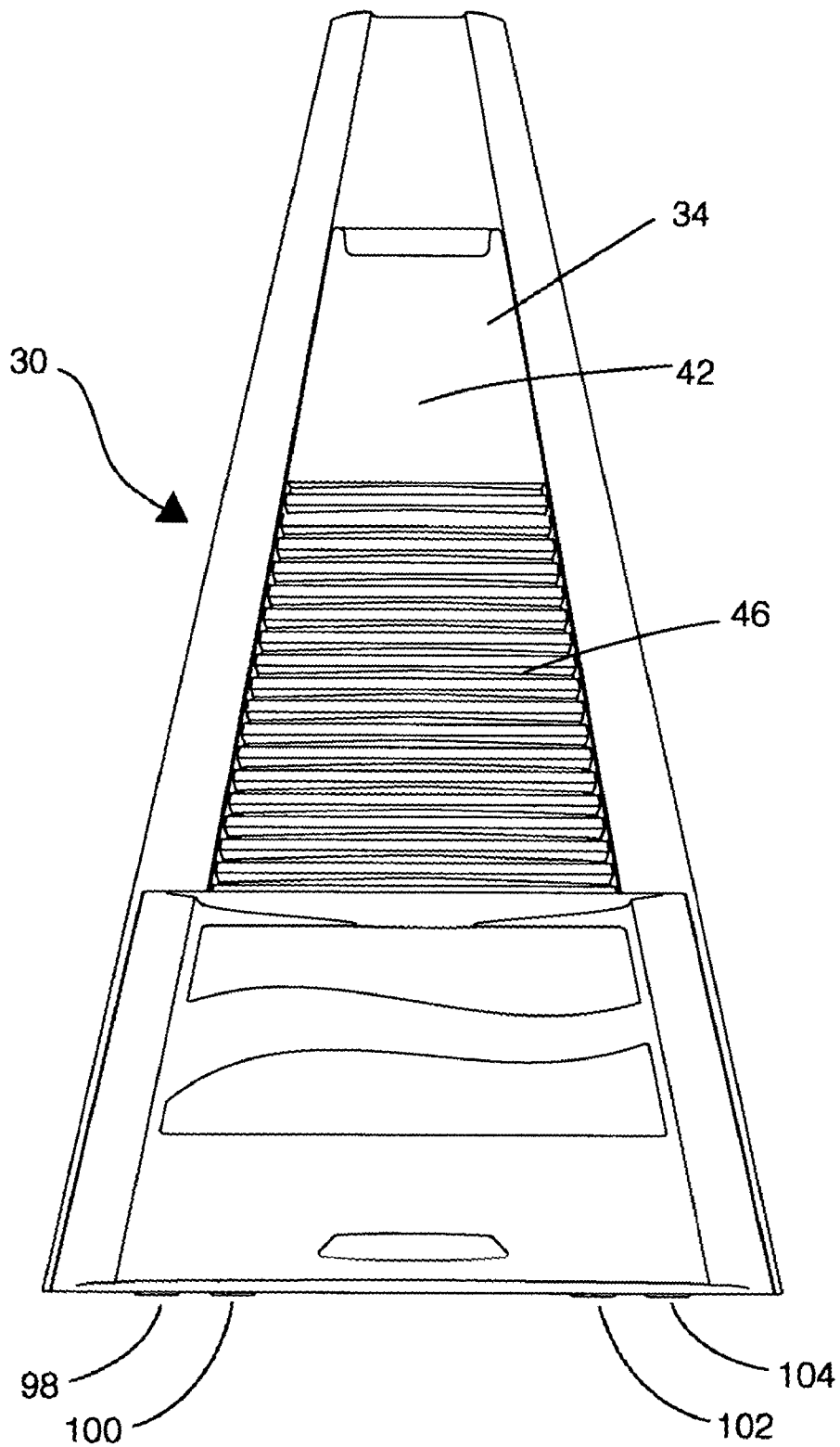

Figure 2

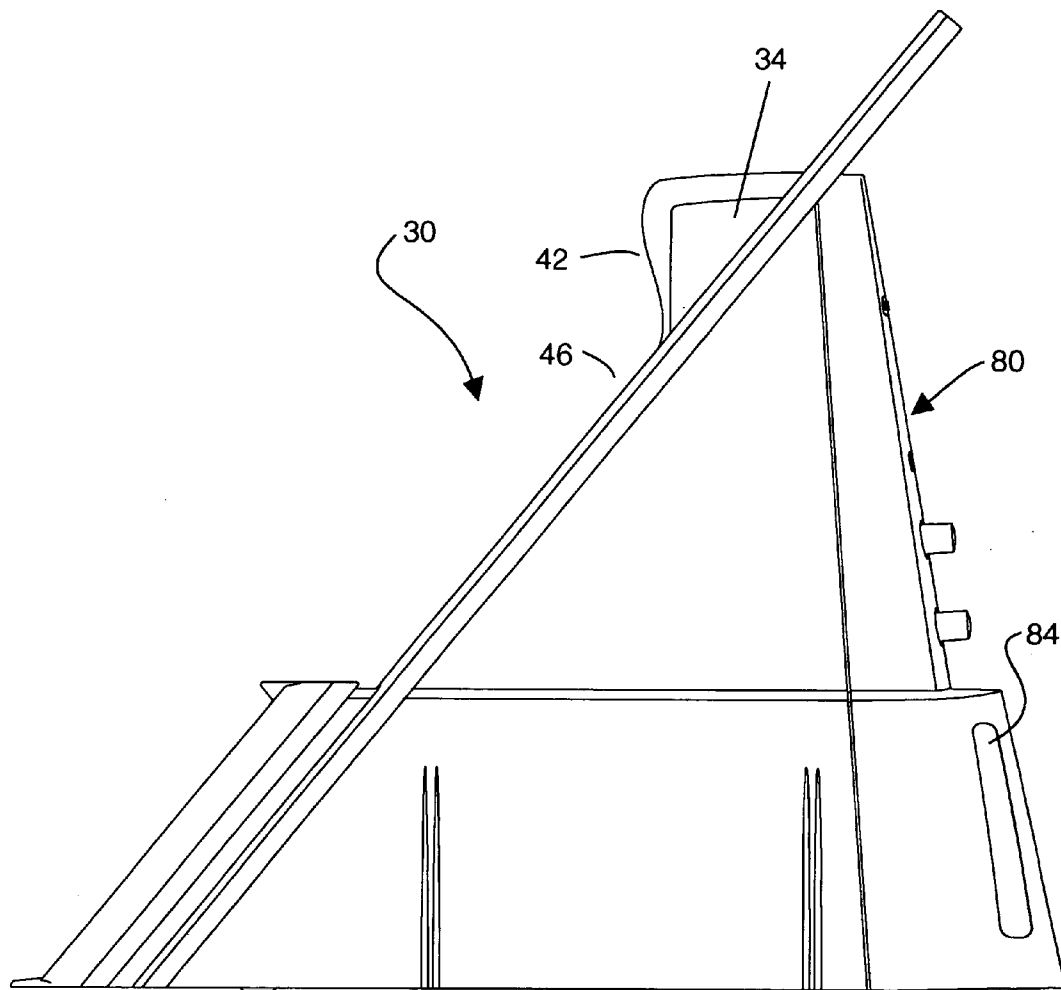

Figure 3

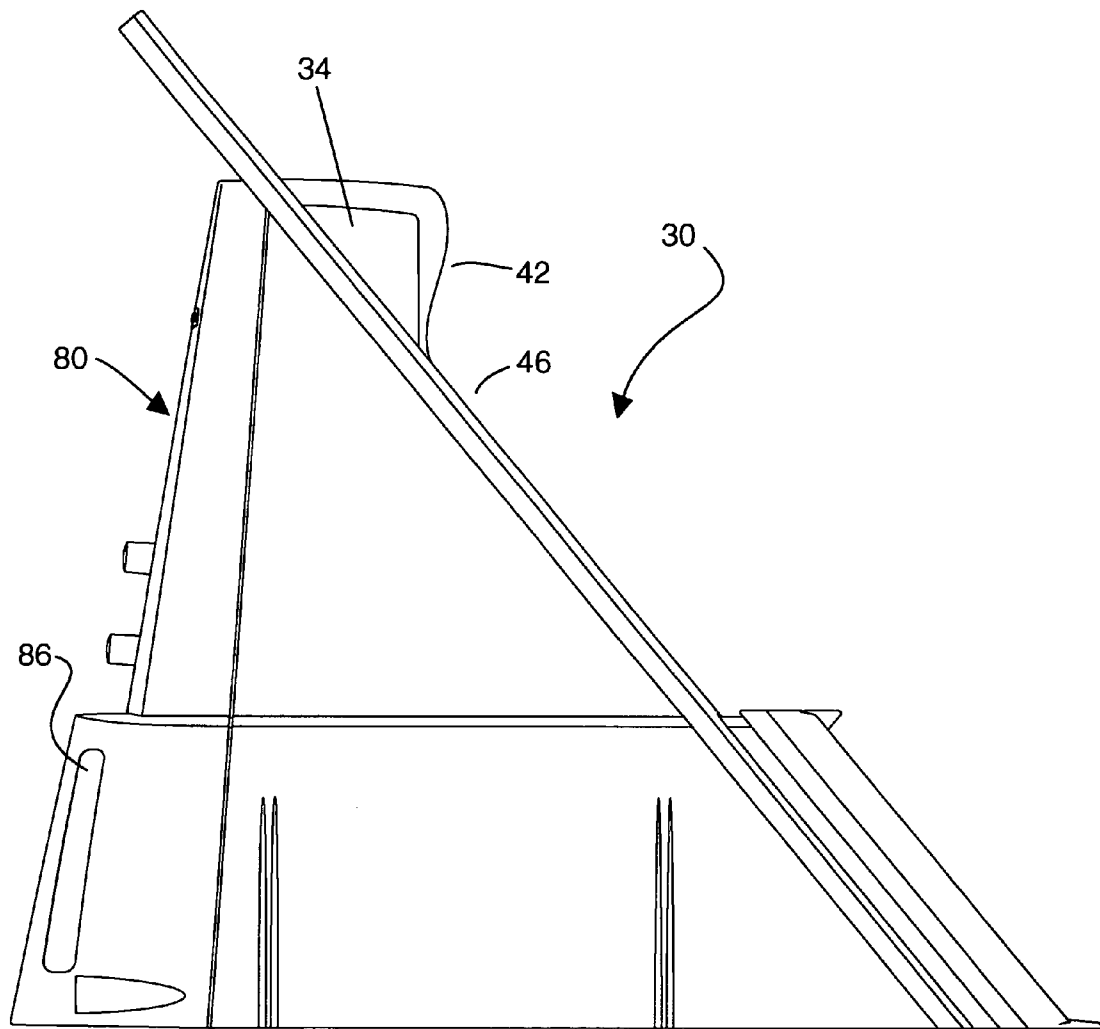

Figure 4

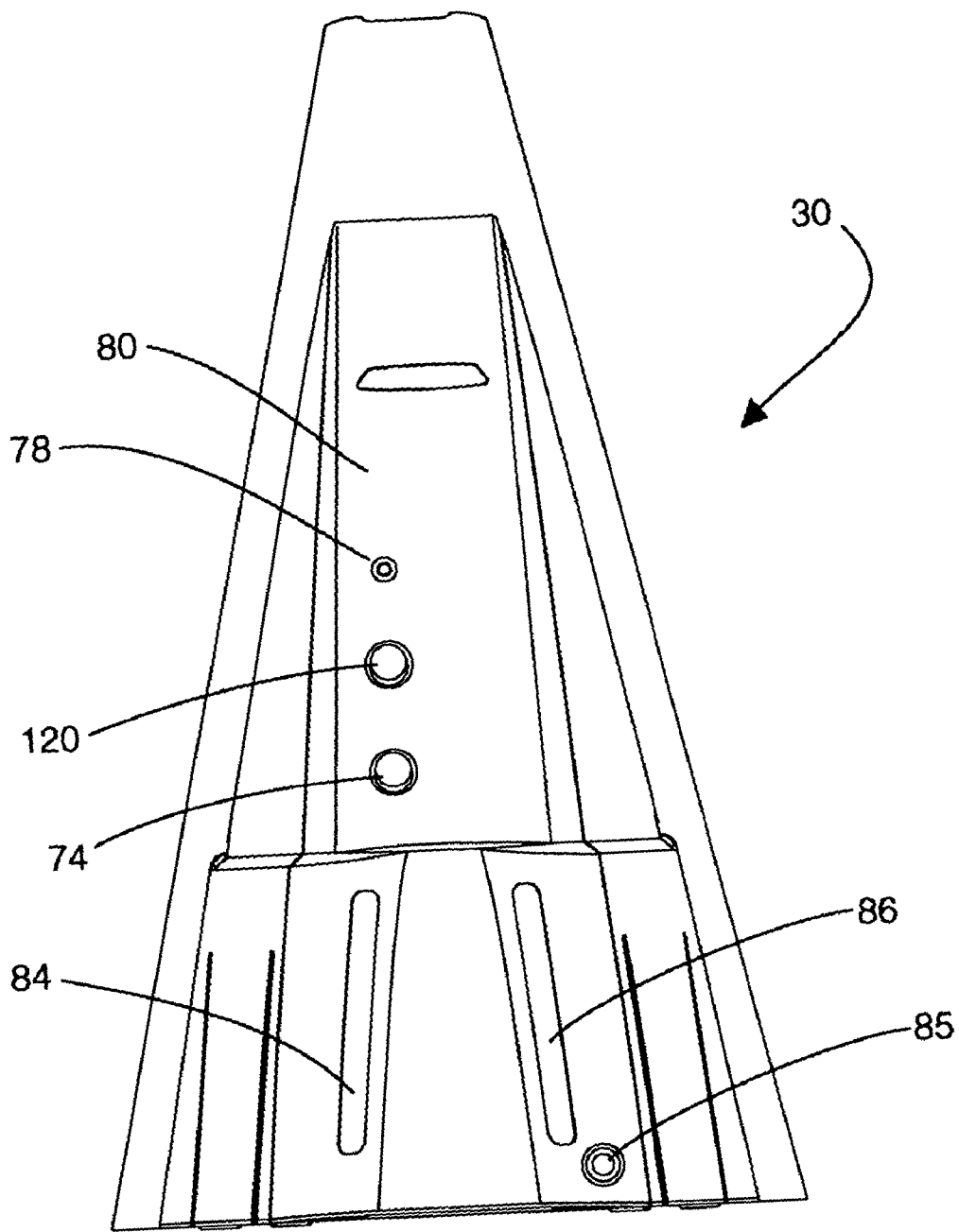

Figure 5

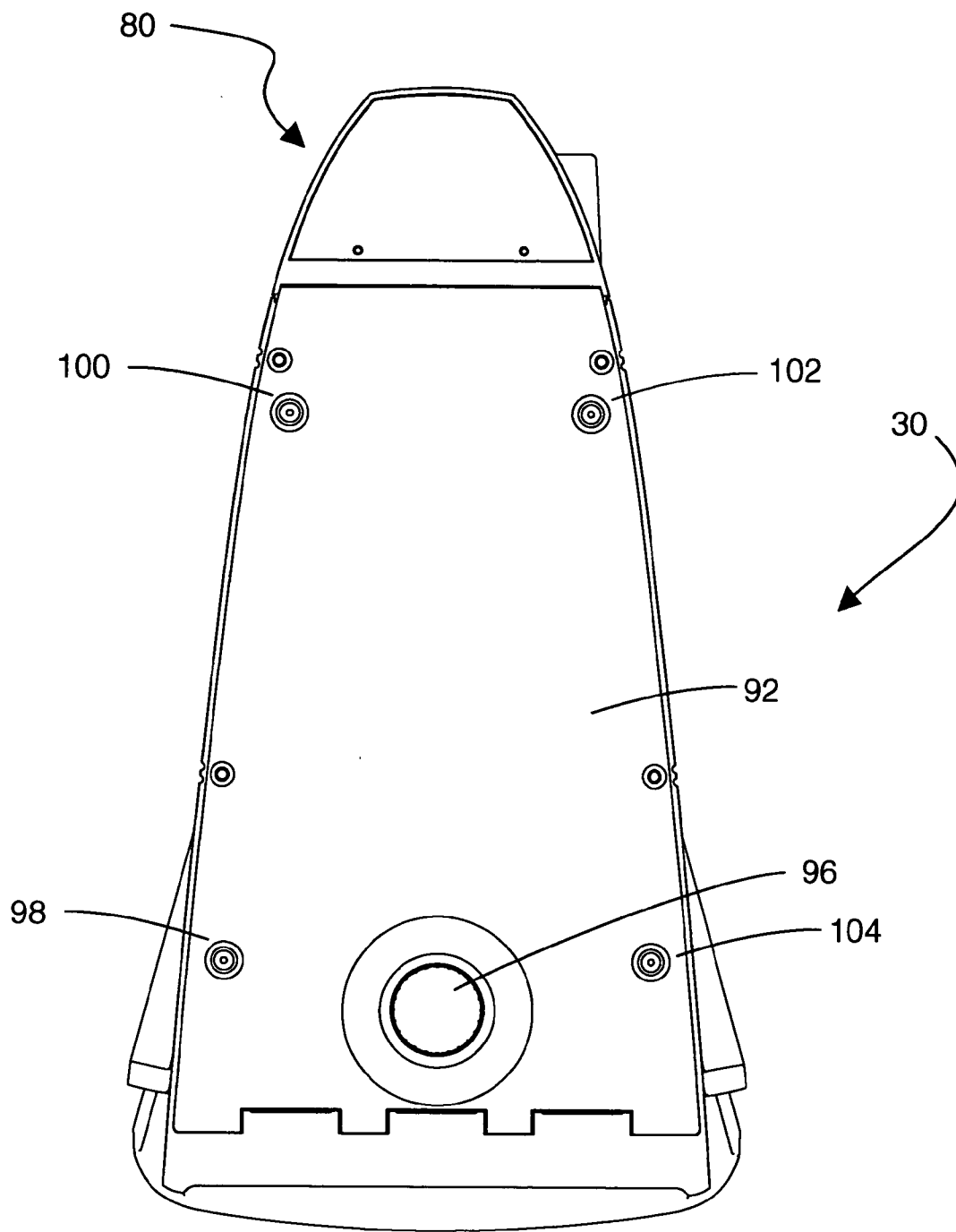

Figure 6a

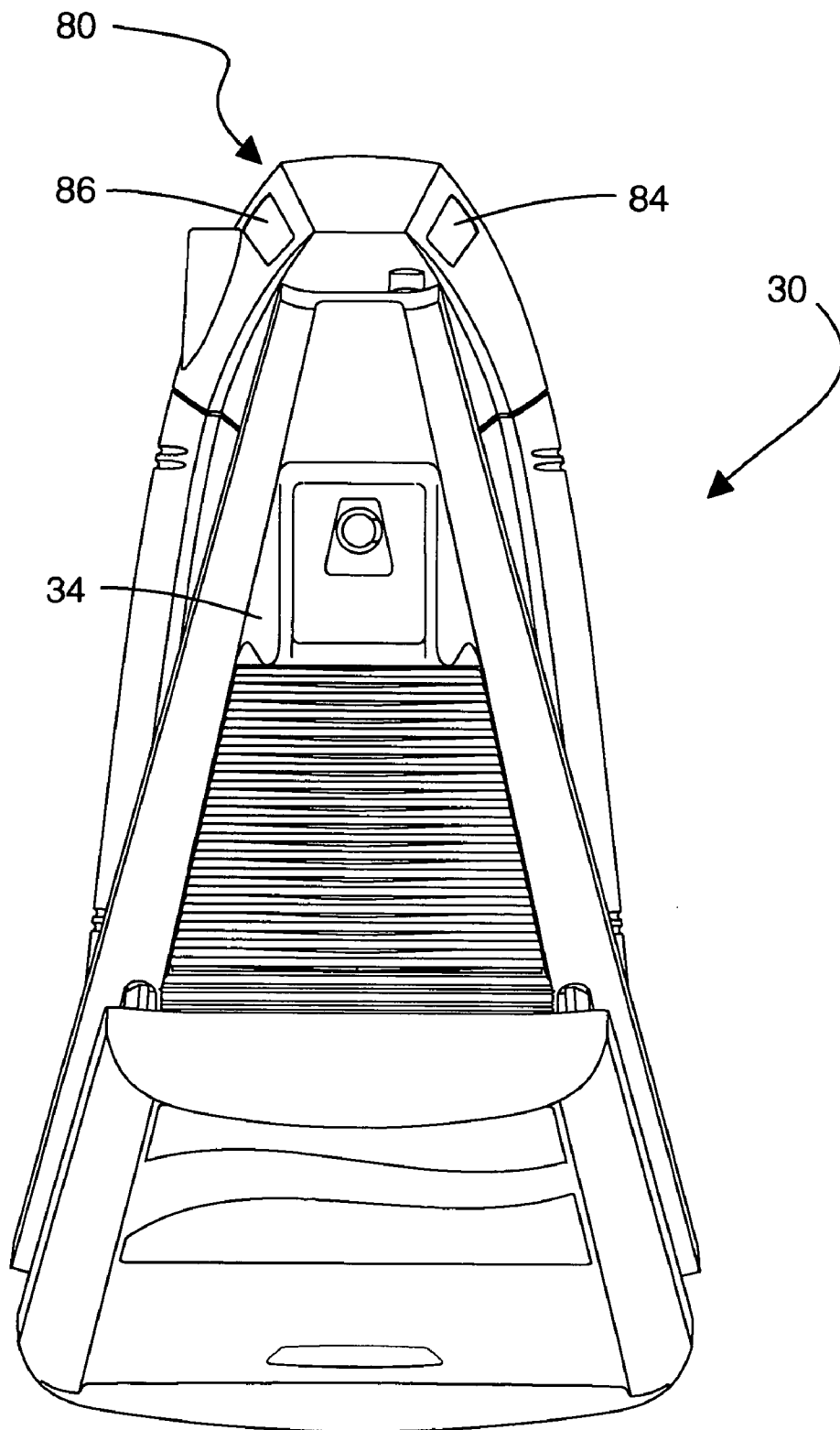
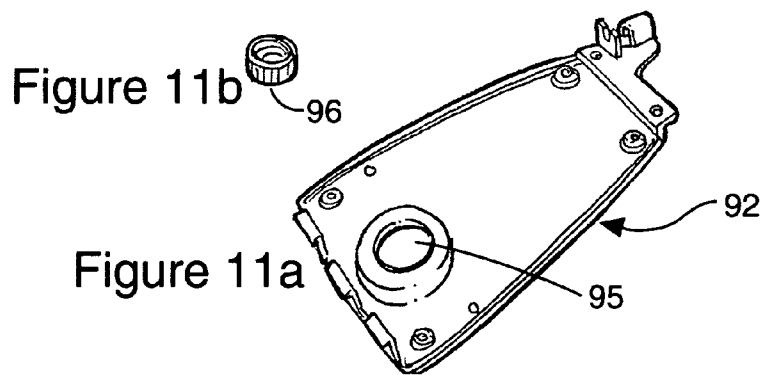
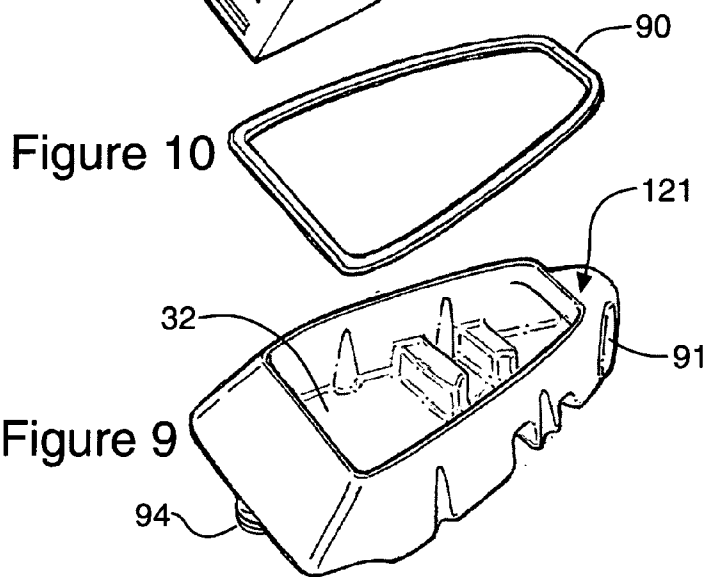
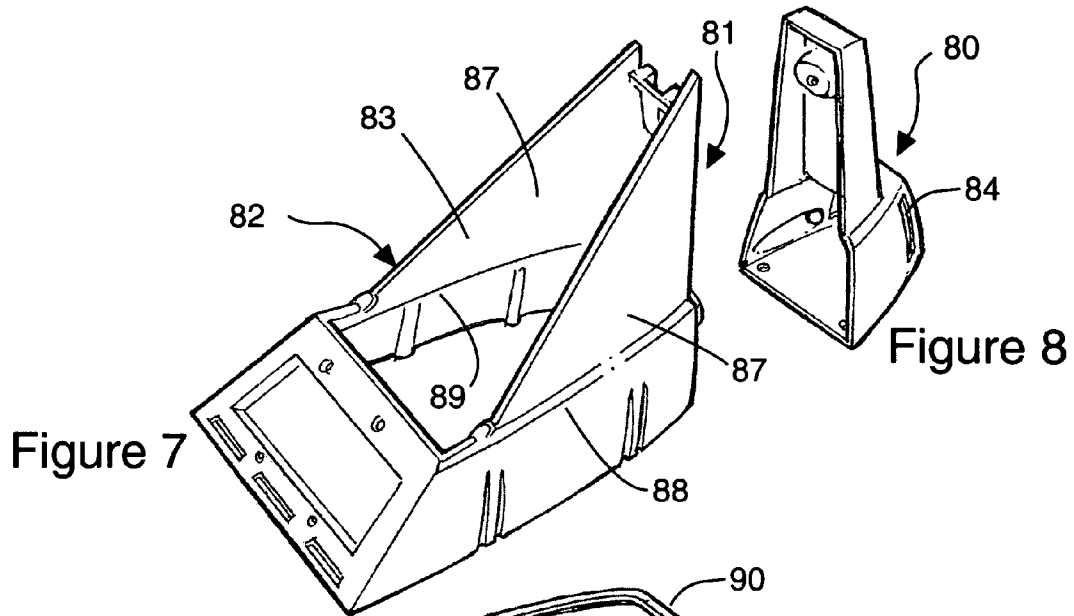
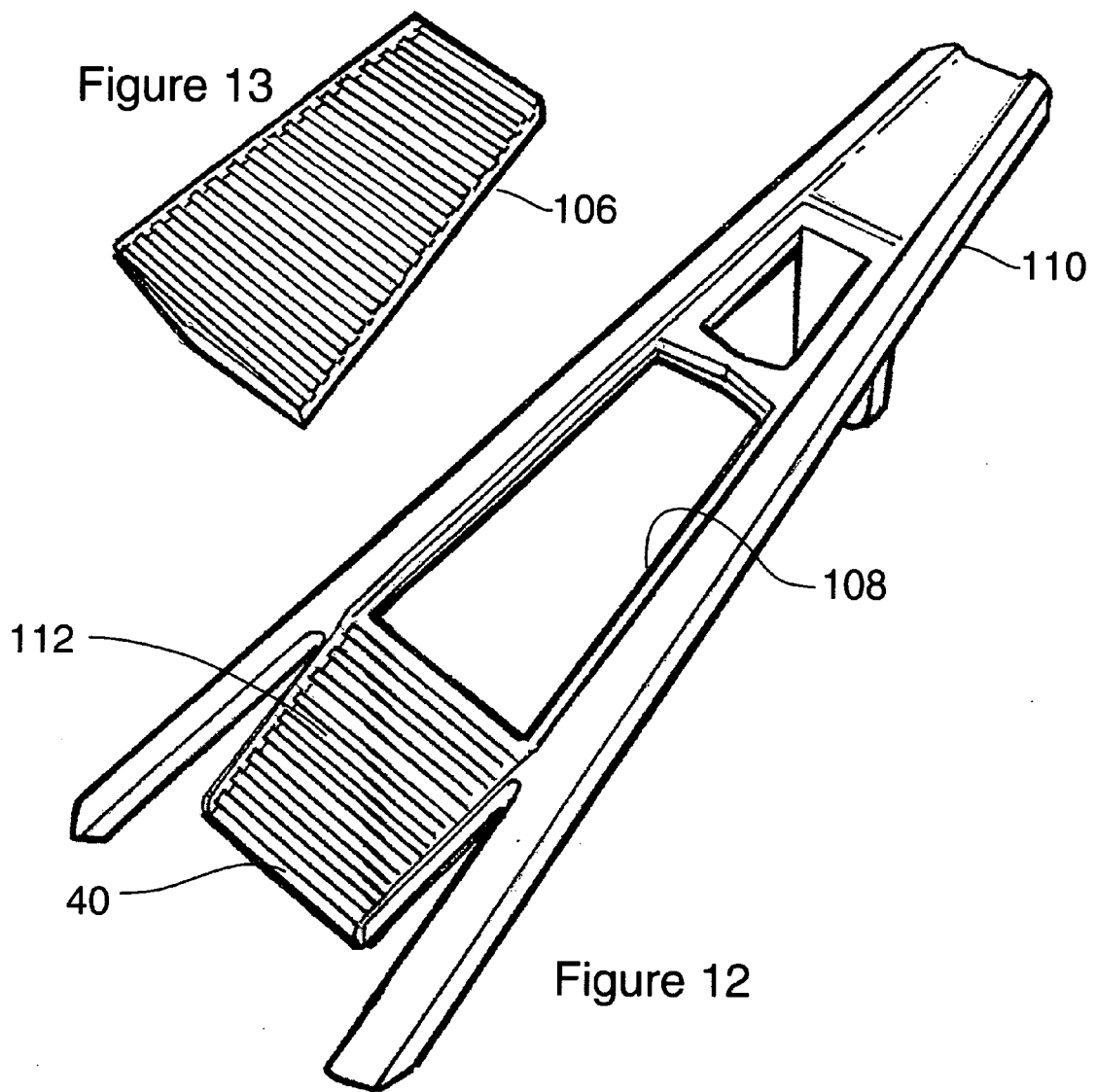

Figure 6b







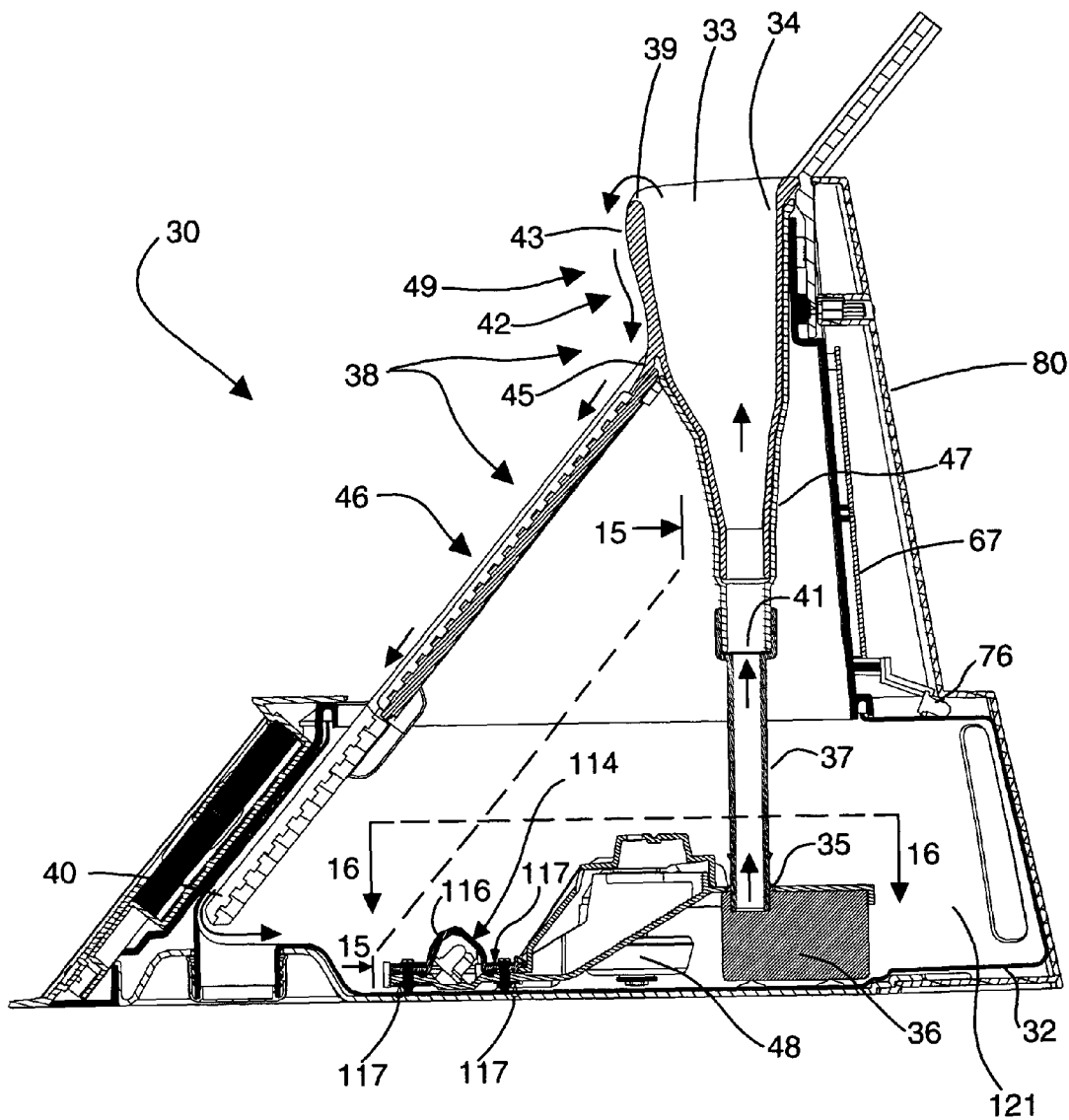

Figure 14

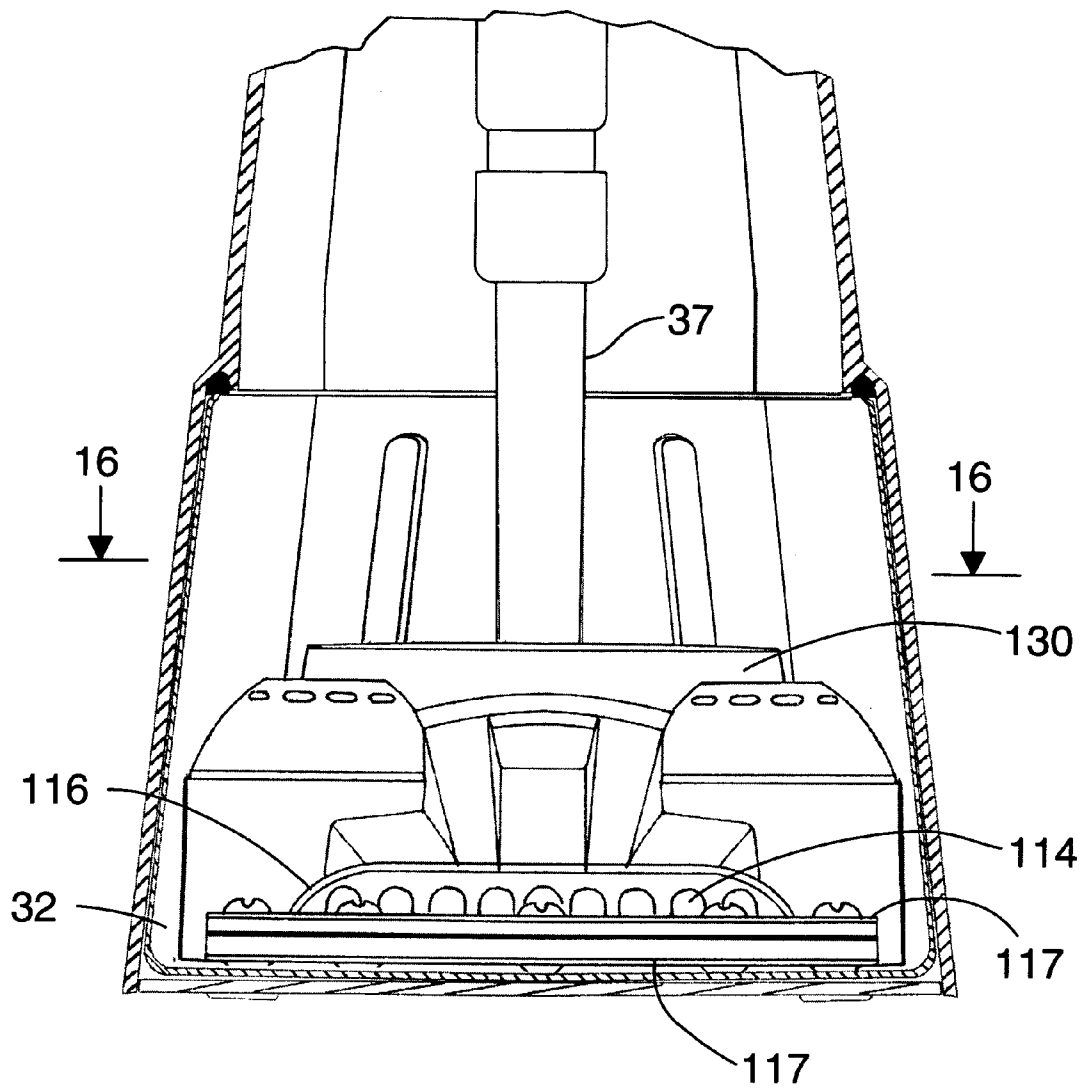

Figure 15

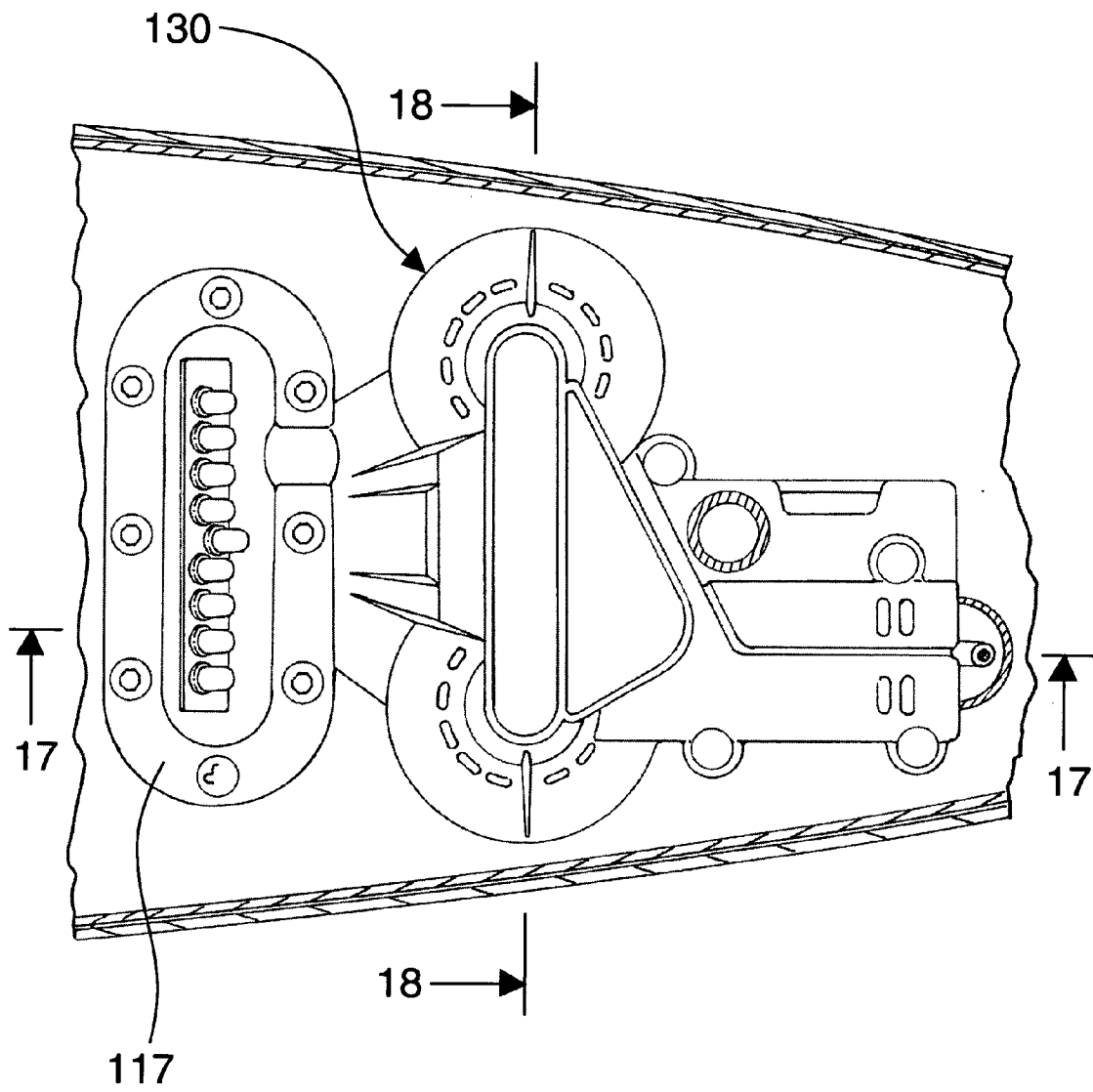

Figure 16

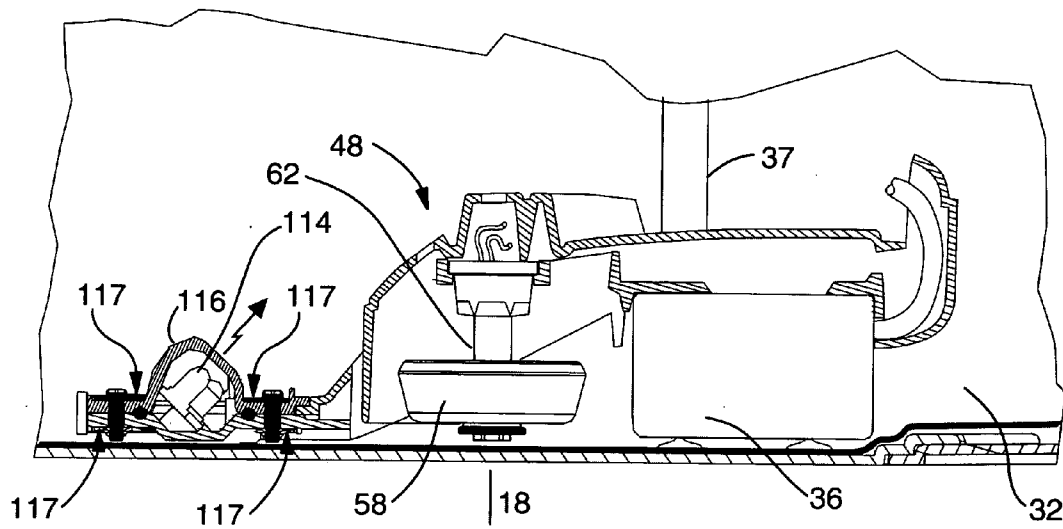

Figure 17

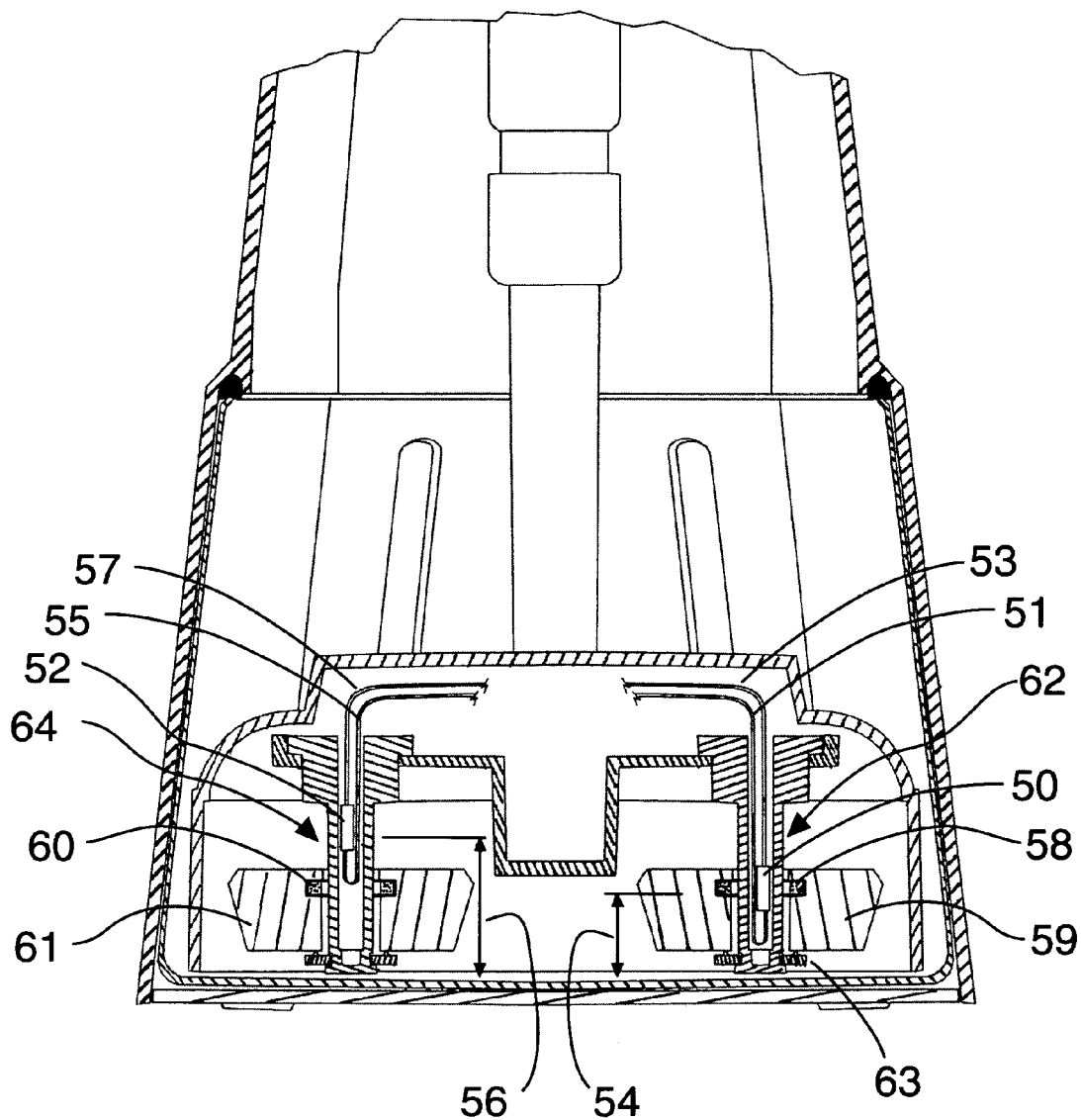
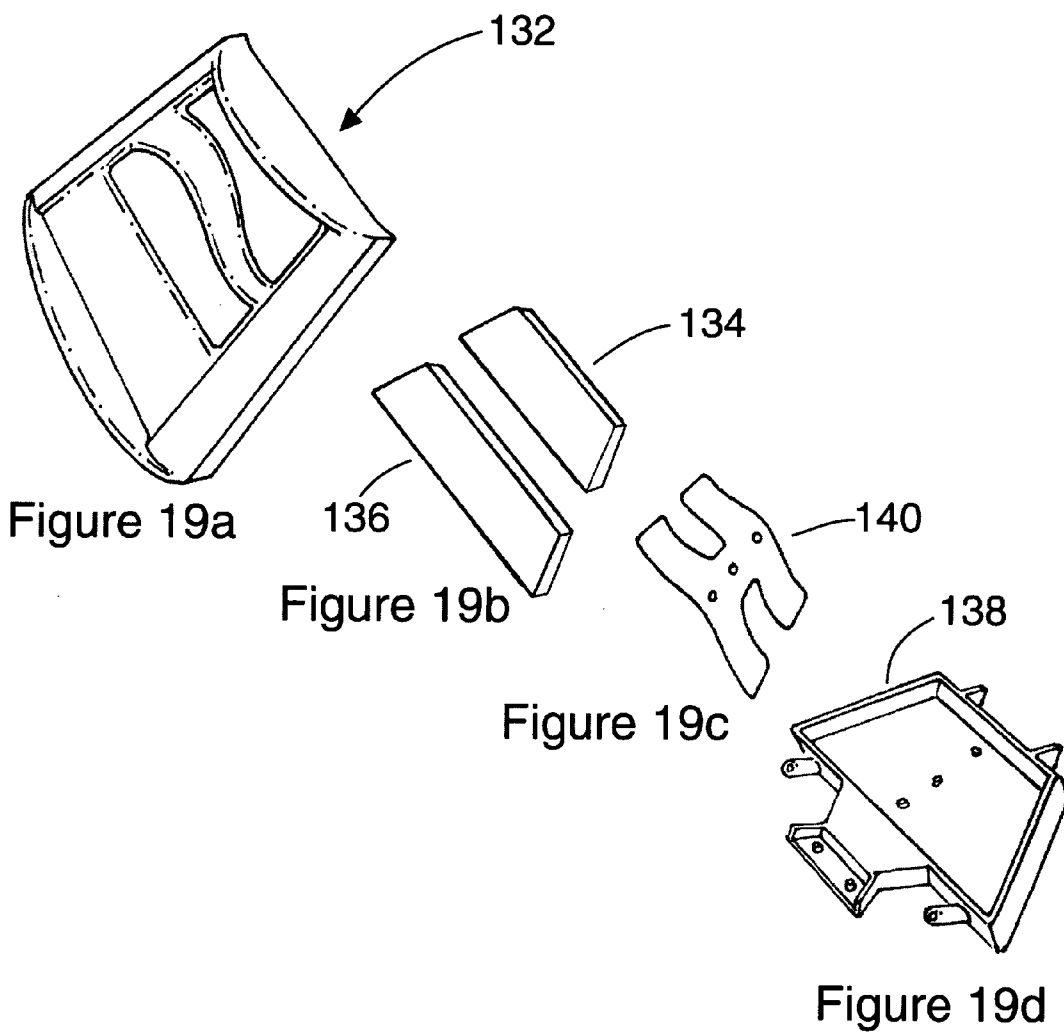

Figure 18





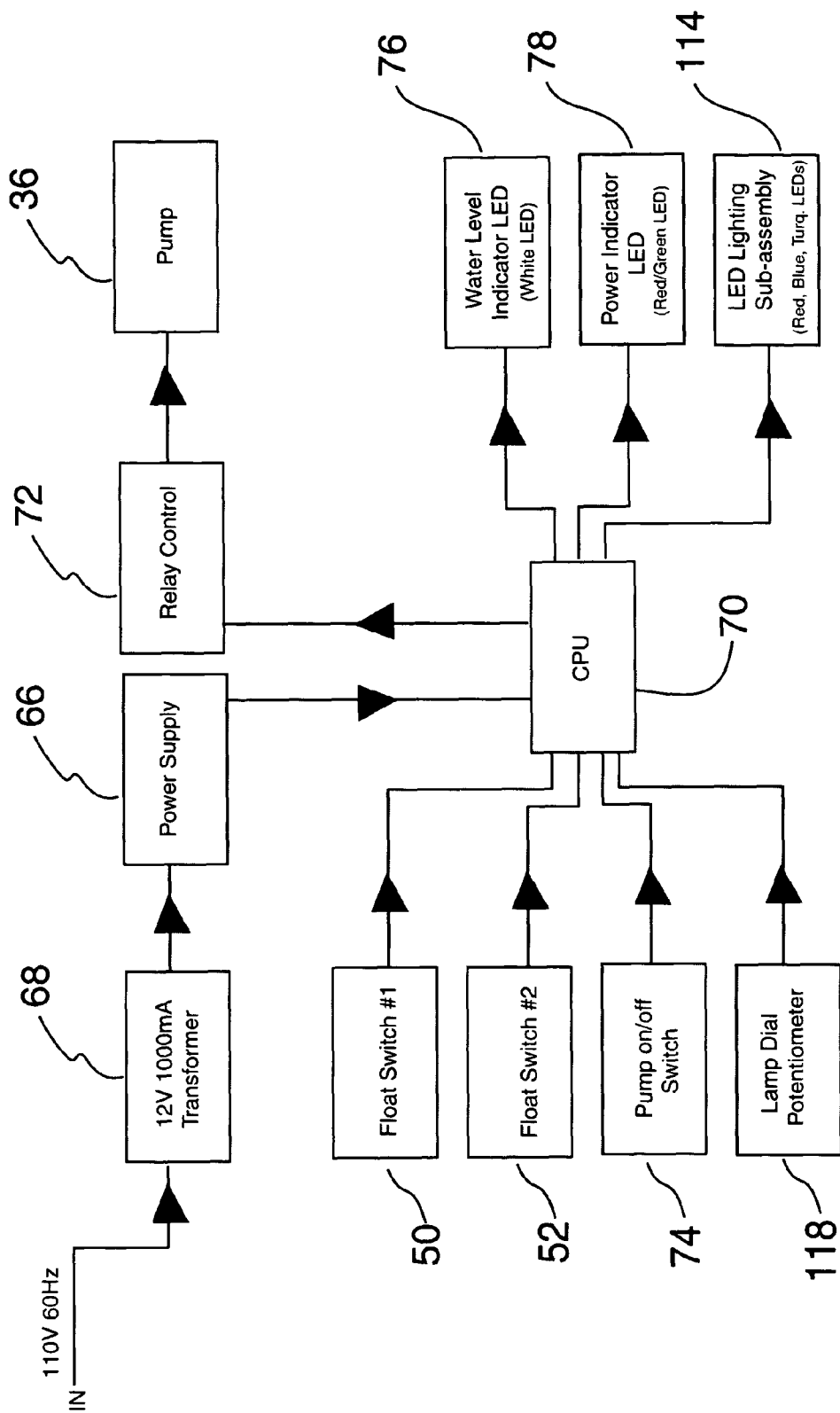

Figure 20

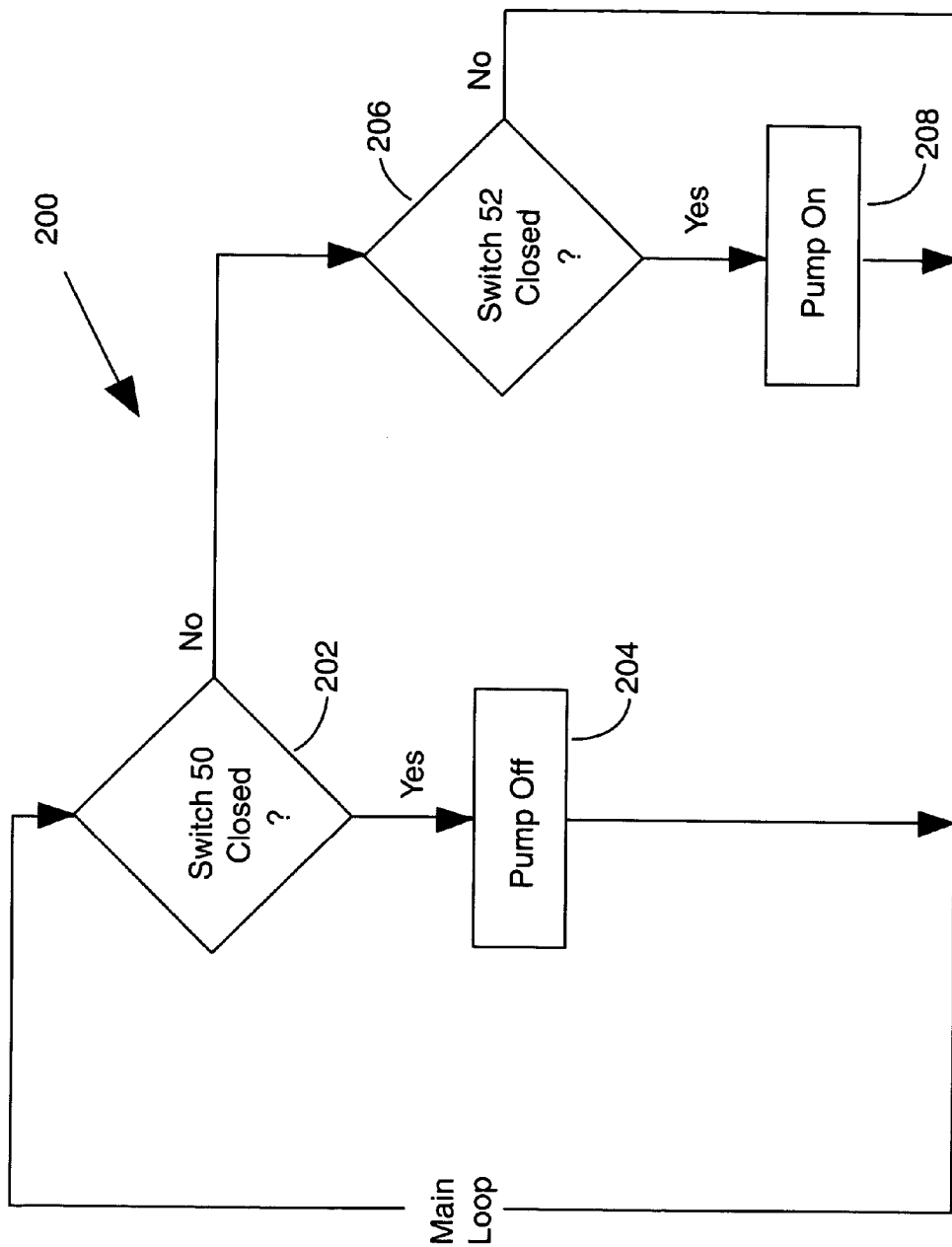

Figure 21

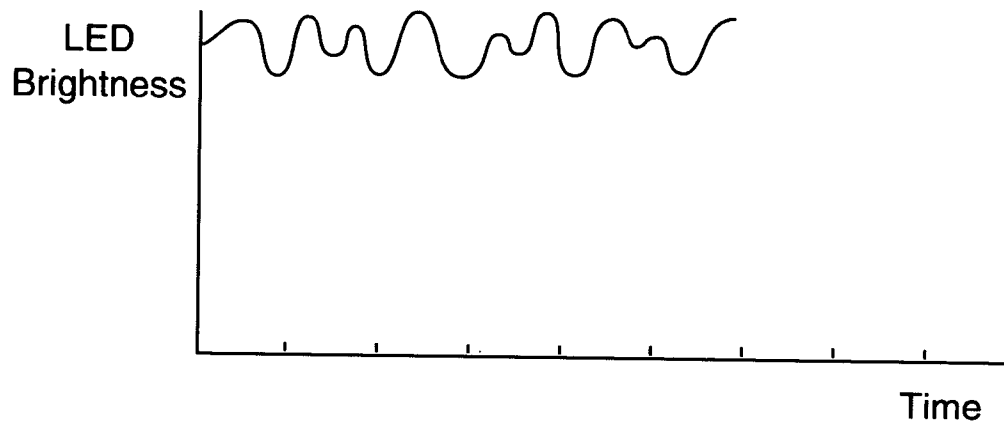

Figure 22

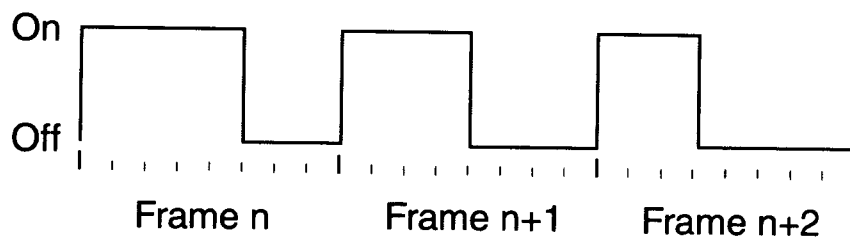

Figure 23

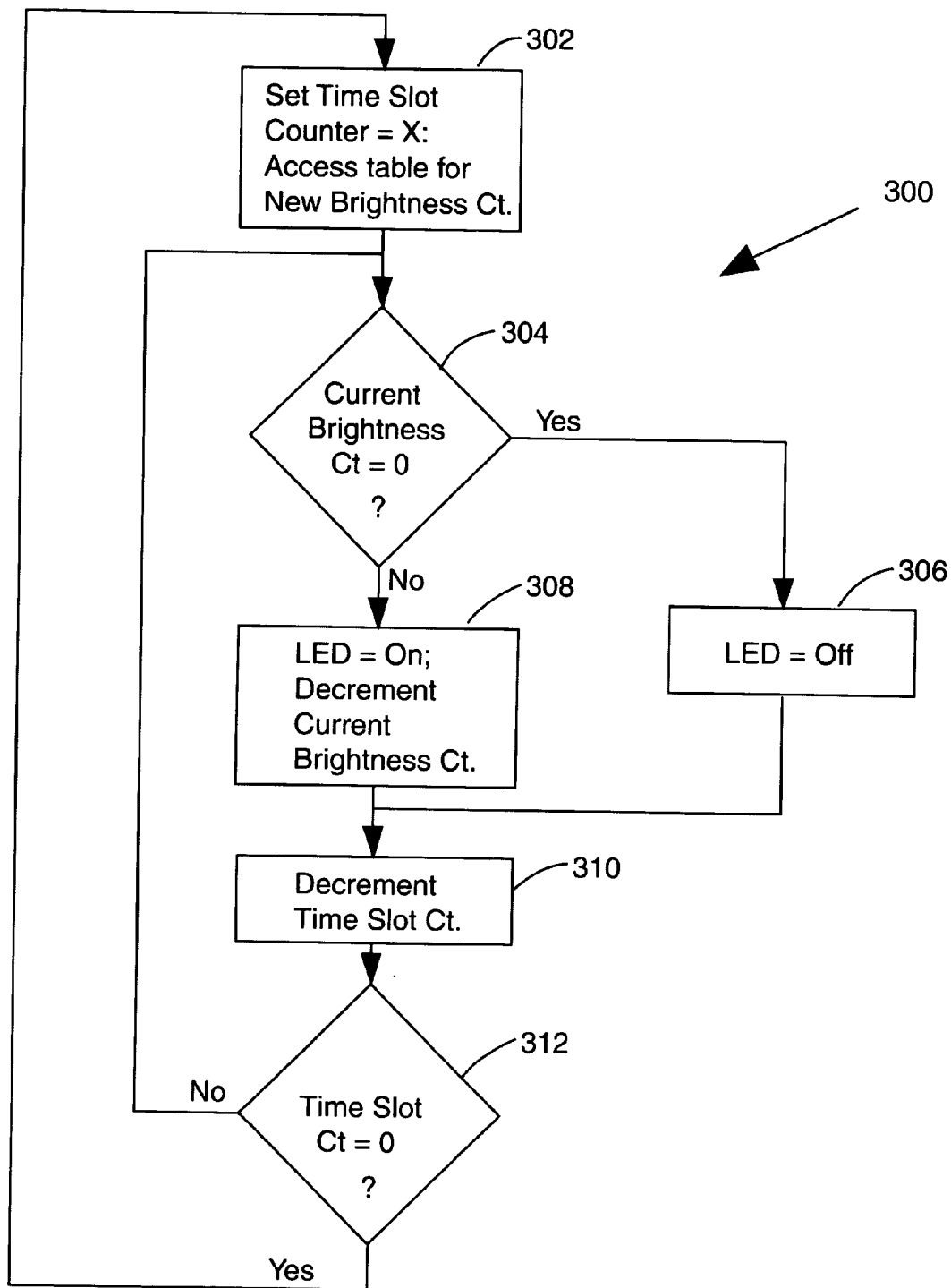

Figure 24

## RECIRCULATING WATER FOUNTAIN

### FIELD OF THE INVENTION

[0001] This invention relates generally to a recirculating water apparatus configured for table/desk top use in a home or office setting to provide pleasing and soothing visual and audible effects.

### BACKGROUND OF THE INVENTION

[0002] As the pace of life continues to quicken, objects designed to draw one's attention to aesthetic pleasures and to nature become increasingly important to a person's well-being. A recirculating water fountain configured for table/desk top use in a home or office setting may help draw one's attention to just such an object in an aesthetically pleasing manner and thus serve to reduce a user's stress level.

### SUMMARY OF THE INVENTION

[0003] The present invention is directed to an apparatus configured for table/desk top use for recirculating a liquid, e.g., water, to produce a visual and audible display which is soothing and relaxing to a user.

[0004] A preferred apparatus in accordance with the invention utilizes a liquid reservoir, e.g., a tub, for containing a volume of water. An electric pump is mounted in the tub for pumping water up a substantially vertically oriented pipe to a plenum. The plenum is configured and dimensioned to pond the water, i.e., to form an essentially still water pool. The plenum is constructed to overflow onto a visually open water flow pathway which then returns the water flow to the tub.

[0005] In accordance with a significant aspect of the invention, an automatic shut off subsystem is provided to prevent the pump from running dry. A shut off subsystem in accordance with the invention functions to sense the water level in the tub when the pump is running, (i.e., pump-on mode). If the "running" water level falls below a first height mark (typically attributable to evaporation), a controller shuts off the pump. When the pump shuts off (i.e., pump-off mode), water within the system, e.g., pipe, plenum, ramp, etc., drains back into the tub and raises the "non-running" water level above the first height mark. In accordance with a significant aspect of the invention, the controller prevents resumption of pump operation until the water level rises, e.g., by the user adding water, above a second height mark greater than the first height mark.

[0006] A preferred shut off subsystem embodiment utilizes at least one switch actuator in combination with first and second switches. The switch actuator, e.g., a magnet, is configured to float in the water-filled tub. The first and second switches, e.g., reed switches, are respectively mounted proximate to the first and second height marks and are configured to respond to the proximity of the switch actuator. In operation, when the water level and the floating switch actuator drop below the first height mark, the first switch is triggered to turn off the pump. After water is added to the tub to raise the water level and the floating switch actuator above the second height mark, the second switch is triggered to enable pump operation to resume.

[0007] The aforementioned flow pathway is preferably configured to allow the water overflow from the plenum to

form an essentially thin sheet as it flows by way of gravity along the pathway toward the tub. The pathway preferably includes a first portion defining convex and concave surfaces which guide the sheet flow along a visually pleasing generally sinuous path. The pathway preferably also includes a second portion comprising a ramp surface which is preferably ridged to produce a rippling effect so as to produce desirable visual and audible water effects.

[0008] A preferred apparatus in accordance with the invention includes a housing having wall portions extending peripherally around the tub and flow pathway. The wall portions extend above the tub and preferably converge upwardly to form a slender and attractive table/desk top accessory. The interior housing wall portions are preferably sealed to the tub to prevent leakage therebetween. The housing exterior is preferably configured to display one or more decorative panels.

[0009] In accordance with a further aspect of a preferred embodiment, the sealed tub and housing include at least one peripheral window enabling the liquid level in the tub to be viewed from outside the housing.

[0010] In accordance with a still further aspect of a preferred embodiment, one or more illumination sources, e.g., LEDs, may be mounted in the tub, preferably below the water level, to produce a variety of pleasing and colorful lighting effects. The flow pathway preferably includes at least one light transmissive portion enabling the lighting effects to be seen from outside the housing. This and other aspects of the present invention will become apparent from a review of the accompanying drawings and the following detailed description of the preferred embodiments of the present invention.

### BRIEF DESCRIPTION OF THE DRAWINGS

[0011] The invention is generally shown by way of example in the accompanying drawings in which:

[0012] **FIG. 1** is a perspective view of a preferred recirculating liquid fountain in accordance with the present invention;

[0013] **FIG. 2** is a front view of the recirculating liquid fountain of **FIG. 1**;

[0014] **FIG. 3** is a left side view of the recirculating liquid fountain of **FIG. 1**;

[0015] **FIG. 4** is a right side view of the recirculating liquid fountain of **FIG. 1**;

[0016] **FIG. 5** is a rear view of the recirculating liquid fountain of **FIG. 1**;

[0017] **FIG. 6a** is a bottom view of the recirculating liquid fountain of **FIG. 1**;

[0018] **FIG. 6b** is a top view of the recirculating liquid fountain of **FIG. 1**;

[0019] **FIG. 7** is a side perspective view of a housing for the recirculating liquid fountain of **FIG. 1**;

[0020] **FIG. 8** is a perspective view of a back cover of the recirculating liquid fountain of **FIG. 1** adapted for coupling with the housing of **FIG. 7**;

[0021] FIG. 9 is a perspective view of a liquid reservoir (tub) of the recirculating liquid fountain of FIG. 1 adapted for mounting within the housing of FIG. 7;

[0022] FIG. 10 is a top perspective view of a tub seal for use with the liquid reservoir (tub) of the recirculating liquid fountain of FIG. 1;

[0023] FIG. 11a is a top perspective view of a bottom cover of the recirculating liquid fountain of FIG. 1;

[0024] FIG. 11b is a perspective view of a drain cap for use with the bottom cover of FIG. 11a;

[0025] FIG. 12 is a perspective view of a front ramp portion of the recirculating liquid fountain of FIG. 1;

[0026] FIG. 13 is a perspective view of a ramp window adapted for coupling with the front ramp portion of the recirculating liquid fountain of FIG. 1;

[0027] FIG. 14 is a cross-sectional view taken substantially along the plane 14-14 of FIG. 1;

[0028] FIG. 15 is a cross-sectional view taken substantially along the plane 15-15 of FIG. 14;

[0029] FIG. 16 is a cross-sectional view taken substantially along the plane 16-16 of FIG. 14;

[0030] FIG. 17 is a cross-sectional view taken substantially along the plane 17-17 of FIG. 16;

[0031] FIG. 18 is a cross-sectional view taken substantially along the plane 18-18 of FIG. 16;

[0032] FIG. 19a is a front perspective view of a face plate for use with the recirculating liquid fountain of FIG. 1;

[0033] FIG. 19b is a front perspective view of a plurality of decorative members for mounting onto the face plate of FIG. 19a;

[0034] FIG. 19c is a top perspective view of a bracket spring for use in mounting the decorative members of FIG. 20b onto the face plate of FIG. 19a;

[0035] FIG. 19d is a top perspective view of a bracket for use in mounting one of the decorative members of FIG. 19b onto the face plate of FIG. 19a; and

[0036] FIG. 20 is a block diagram of a microprocessor based electronic module for use in the fountain of FIG. 1;

[0037] FIG. 21 is a flow chart depicting a pump shut off routine;

[0038] FIG. 22 is a diagram depicting a flicker lighting effect;

[0039] FIG. 23 is a diagram depicting exemplary LED on/off modulation to achieve a desired lighting effect; and

[0040] FIG. 24 is a flow chart depicting a flicker routine.

#### DETAILED DESCRIPTION

[0041] Attention is initially directed to FIGS. 1-6 which illustrate a preferred recirculating liquid apparatus (fountain) 30 in accordance with the present invention. The apparatus 30 is configured for table/desk top use, typically in a home or office setting, for producing a visual and audible liquid flow display which is pleasing and relaxing to the user.

[0042] The preferred fountain apparatus 30 generally comprises a reservoir (tub) 32 (FIGS. 9, 14) for accommodating a volume of liquid such as water, a removable plenum 34 (FIGS. 1-4, 14) mounted generally above reservoir 32 and adapted to accumulate a substantially still liquid (water) pool 33 (FIG. 14), and a high efficiency submersible water pump 36 (FIGS. 14, 17) mounted within reservoir 32. The water pump 36 is preferably selected to operate at an almost zero sound level. Plenum 34 is of a generally truncated inverted pyramidal shape to allow the gradual increase in water volume as the water is pumped upward from tub 32 so as to reduce turbulence and form a substantially still water pool 33 (FIG. 14) in the plenum 34. Plenum 34 preferably includes a face portion 49 defined by generally smooth surface having convex and concave portions 43, 45, respectively, as generally depicted in FIG. 14. Water pump 36 is selectively operable in a "pump-on" mode to pump water upwardly from reservoir (tub) 32 via a pipe 37 (FIG. 14) to form the water pool 33 in plenum 34. Specifically, pipe 37 is coupled between an outlet port 35 of submersible pump 36 and an inlet port 41 of a center bracket 47 configured to support plenum 34, as generally shown in FIG. 14.

[0043] The recirculating water fountain 30 preferably includes a visually open flow pathway 38 which includes a first curved flow portion 42 generally defined by the convex and concave plenum surfaces 43, 45, respectively, and a second ramp portion 46 sloping downward from beneath plenum 34, as illustrated in FIGS. 1-4, 14. The ramp portion 46 is defined in part by a generally polygonal ramp window 106 made preferably of a light transmissive material(s). Ramp window 106 may be removably mounted onto frame 108 of a generally elongate ramp support structure 110 as shown in FIGS. 12-13. Ramp support structure 110 (FIG. 12) preferably mounts onto a front portion 83 of a housing 82 (FIG. 7) of fountain 30 (FIG. 1) and includes a generally polygonal bottom ramp portion 112 (FIG. 12) which further defines the second ramp flow portion 46, as generally illustrated in FIG. 14.

[0044] Plenum 34 is adapted to overflow onto an upstream end 39 of the flow pathway 38 which returns the water flow by gravity to reservoir 32 at a downstream end 40 of bottom ramp portion 112 (FIG. 12) as generally depicted in FIG. 14. Pathway 38 is preferably configured to allow the water overflow from plenum 34 to form an essentially thin sheet as it flows downward toward reservoir 32. Specifically, the plenum surfaces 43, 45 exhibit convex and concave curvatures sufficiently shallow to guide a thin sheet flow along a visually pleasing and substantially smooth sinuous path. The ramp flow portion 46 is adapted to guide the thin sheet water flow along a generally diverging ridged path so as to produce visually pleasing and soothing rippling/cascading effects, as depicted in FIG. 14. Alternatively, first curved flow portion 42 may be provided with a plurality of ridges and/or the ramp flow portion 46 may be made smooth to produce a slightly different water display. Other flow path variations may be utilized, provided such other variations do not depart from the intended purpose of the present invention.

[0045] Housing 82 comprises a generally polyhedral base portion 88 (FIG. 7) adapted to enclose snugly tub 32. Tub 32 edges are preferably sealed to an inside surface 89 (FIG. 7) of base portion 88 (of housing 82) using a tub seal gasket 90 (FIG. 10) which conforms to the outer top contour of tub 32, as generally shown in FIGS. 9-10. Once tub 32 is sealed

to inside surface 89 of housing 82, recirculating water fountain 30 may be rocked, shaken or safely transported from one location to another without leaking water therebetween. Housing 82 comprises a slender generally pyramidal body portion 87 (FIG. 7) which creates a highly attractive aesthetic appearance as it rises from the foot print it occupies on a table/desk top (FIG. 1).

[0046] Tub 32 is preferably blow-molded from a suitable plastic material with the tub and housing design allowing for the incorporation of one or more windows for enabling a user to observe the internal water level. For example, a tub water level aperture 91 (FIG. 9) is designed to match the opening provided by a water level indicator window 84 on back fountain cover 80 (FIGS. 5, 8), respectively. As generally shown in FIG. 5, back fountain cover 80 also includes another oppositely disposed water level indicator window 86. The provision of a water level window allows the user to quickly and easily gauge the level of water inside tub 32 during re-filling and/or use of the fountain.

[0047] Recirculating water fountain 30 also comprises a removable bottom cover 92 (FIGS. 6a, 11a) which may be mounted to the underside of base portion 88 (of housing 82) after tub 32 has been installed. Tub 32 is preferably provided with a generally circular drain opening 94 (FIG. 9). Drain opening 94 protrudes through bottom cover 92 through opening 95 shown in FIG. 11a. Drain opening 94 enables the tub to be emptied and cleaned relatively easily for the user. During use, drain opening 94 is closed by drain cap 96 (FIG. 11b). The underside of bottom cover 92 may be provided with a plurality of integral foot supports 98, 100, 102, 104 (FIG. 2) made of synthetic rubber or similar material(s) to prevent damage to a desk/table top surface while the fountain is in use.

[0048] The water fountain 30 further comprises a pump controller 48 (FIG. 14) operatively coupled to pump 36 and configured to prevent pump 36 from running dry. That is, the controller 48 is configured to automatically monitor the "running water" level in tub 32 and to shut off the pump (i.e., "pump-off" mode) when the water level falls below a first height mark and to prevent resumption of pump operation until the water level exceeds a second height mark, higher than the first height mark. In accordance with the invention, this automatic shut off functionality is achieved by respectively mounting first and second detectors proximate to the first and second height marks. In the preferred embodiment to be discussed in detail hereinafter, each detector comprises a switch which responds to a switch actuator configured to float proximate to the water level in tub 32. For example, the switch actuator can comprise a magnet(s) and the respective detectors can comprise reed switches configured to close when a magnet is proximate thereto.

[0049] More specifically, and with reference to FIG. 18, the pump controller automatic shut off subsystem includes a first reed switch 50 operatively coupled to pump 36 (via electrical connectors 51, 53) and mounted proximate to a first tub height mark 54. A first magnetic actuator 58 is carried by float 59 and positioned to close first reed switch 50 when the water level drops to the first tub height mark 54. More particularly, the float 59 is preferably toroidally shaped and adapted to move vertically on a tubular guide shaft 62 such that it bottoms against stop 63 and closes reed switch 50 when the water level falls to mark 54. The reed switch 50 is preferably encased in resin or similar material(s) for waterproof assembly within the guide shaft 62.

[0050] Pump controller 48 also includes a second reed switch 52 operatively coupled to pump 36 (via electrical

connectors 55, 57) and mounted proximate to a second tub height mark 56. A second magnetic actuator 60 is mounted on float 61 to close reed switch 52 when the water level in tub 32 rises to the second tub height mark 56. The float 61 is generally ring-shaped and is adapted to move vertically on tubular guide shaft 64 which preferably houses the second reed switch 52. The reed switch 52 is preferably encased in resin or similar material(s) for waterproof assembly.

[0051] The pump 36, reed switches 50, 52, and respective magnetic actuators 58, 60, are preferably mounted beneath a removable appropriately shaped pump cover 130, as generally shown in FIGS. 15-16.

[0052] The locations of the first and second tub height marks 54, 56, are selected to allow for the incremental rise in water level which would occur every time pump 36 is shut off. Specifically, every time pump 36 shuts off, all the water above the pump in pipe 37, in plenum 34, as well as on the ramp flow portion 46 flows back to tub 32 by gravity causing an incremental rise in tub water level. Thus, the height difference between the first and second height marks 54, 56 (FIG. 18) should be greater than the measured incremental rise in tub water level due to pump 36 shutting off. When the tub water level has, due to evaporation, diminished below height mark 54 and fails to rise to height mark 56 even with the incremental rise in water level after shut off, pump 36 will safely remain in the pump-off mode until the user manually replenishes the water supply in tub 32. Water may be easily replenished by the user by removing ramp window 106 from ramp support structure 110 and pouring water into tub 32.

[0053] In typical use, pump 36 may operate for about two weeks, depending on the humidity of the operating environment, before shutting off as a consequence of evaporation. In general, the amount of time between required refills is a function of tub size, amount of water being used in the tub, efficiency of the pump, humidity of the operating environment, as well as how water recirculation is managed within the fountain, i.e. how much water is being lost to evaporation due to heat produced by internal lighting sources. Conventional recirculating water fountain designs typically utilize internal halogen light sources which have been found to cause a significant rise in water temperature during operation of the fountain thereby substantially increasing the speed of water evaporation. To resolve this problem, and in accordance with the present invention, fountain 30 preferably utilizes an internal low voltage LED lighting sub-assembly 114 (FIG. 14) characterized by much lower level of heat generation when compared to conventional halogen lighting sources. Another advantage of using low voltage LED lighting sources is a much longer LED life expectancy (at least 10 years), while conventional halogen lighting sources typically burn out in less than 4 months.

[0054] More particularly, LED lighting sub-assembly 114 preferably comprises a series of five blue LEDs, two red LEDs, and two turquoise LEDs being hermetically sealed under pressure via a generally ring-shaped metal frame 117 (FIG. 16) in a waterproof light transmissive housing 116, as generally illustrated in FIGS. 14-17. Metal frame 117 is preferably mounted to the bottom surface of tub 32 substantially behind light transmissive ramp window 106, as generally shown in FIGS. 14-17, so as to illuminate open flow pathway 38 in a combination of colors during operation of fountain 30.

[0055] Each LED of lighting sub-assembly 114 preferably comprises an ultra bright LED with a relatively wide range

of illumination. The nine LEDs of lighting sub-assembly **114** are adapted to produce fifteen separate color combinations. The color combinations are controlled by a lamp dial **118** (**FIG. 20**) which is mechanically coupled to a LED dial switch **120** (**FIG. 5**). LED dial switch **120** is adapted to cycle through fifteen different color combinations and is operatively coupled to back fountain cover **80** (**FIG. 8**). Back fountain cover **80** is adapted for mounting to a respective back portion **81** (**FIG. 7**) of housing **82**, as generally depicted in **FIGS. 3-5**.

[0056] In use, turning LED dial switch **120** (**FIG. 5**) all the way in a counter-clockwise direction would result in LED lighting subassembly **114** being turned off. Turning LED dial switch **120** in a clockwise direction cycles lighting subassembly **114** through fifteen different positions (color combinations). What follows is a typical color combination layout:

[0057] Position **1**=1 Blue LED being "on". (Light Blue), (Center Blue LED);

[0058] Position **2**=4 Blue LEDs being "on". (Medium Blue), (2 Left Blue LEDs and 2 Right Blue LEDs);

[0059] Position **3**=5 Blue LEDs being "on". (All 5 Blue LEDs);

[0060] Position **4**=5 Blue LEDs being "on", 2 Turquoise LEDs being "on";

[0061] Position **5**=4 Blue LEDs being "on", 2 Turquoise LEDs being "on". (2 Left Blue LEDs, 2 Right Blue LEDs, 2 Turquoise LEDs);

[0062] Position **6**=1 Blue LED being "on", 2 Turquoise LEDs being "on". (Center Blue LED and 2 Turquoise LEDs);

[0063] Position **7**=2 Turquoise LEDs being "on";

[0064] Position **8**=2 Turquoise LEDs being "on", 2 Red LEDs being "on";

[0065] Position **9**=2 Turquoise LEDs being "on", 2 Red LEDs being "on", 1 Blue LED being "on". (White LED) (Center Blue LED);

[0066] Position **10**=2 Turquoise LEDs being "on", 2 Red LEDs being "on", 4 Blue LEDs being "on". (2 Left Blue LEDs, 2 Right Blue LEDs);

[0067] Position **11**=2 Turquoise LEDs being "on", 2 Red LEDs being "on", 5 Blue LEDs being "on".

[0068] Position **12**=2 Red LEDs being "on", 5 Blue LEDs being "on".

[0069] Position **13**=2 Red LEDs being "on", 4 Blue LEDs being "on". (2 Red LEDs, 2 Left Blue LEDs, 2 Right Blue LEDs);

[0070] Position **14**=2 Red LEDs being "on", 1 Blue LED being "on". (2 Red LEDs, Center Blue LED); and

[0071] Position **15**=2 Red LEDs being "on".

[0072] It should be noted that as new colors are created in LED technology, new colors can be added/upgraded to fountain **30**.

[0073] A preferred water fountain **30** may be energized by an internal power supply **66** (**FIG. 20**) which is electrically connected to a 110V, 60 Hz power source via an external

12V, 1000 mA transformer **68**. Power supply **66** provides power to a controller, or central processing unit (CPU) **70**, which controls the operation of pump **36**, i.e. turns pump **36** on/off via a relay control **72** in response to input signals from the first and second switches **50**, **52**, respectively, and from a manual pump on/off switch **74**. Pump on/off switch **74** may be a standard two-position dial knob switch operatively coupled to back cover **80** of fountain **30**, as generally shown in **FIG. 5**. For example, turning pump switch **74** in a counter-clockwise/clockwise direction will open/close the circuit, respectively. Closing the circuit will enable pump **36** and LED lighting subassembly **114** to operate as long as the water tub level is at second tub height mark **56** (**FIG. 18**) or higher.

[0074] The CPU **70** controls multiple functions including lighting control and pump shut-off operation. **FIG. 21** comprises a flow chart depicting execution of a routine **200** for performing the previously described automatic pump shut-off function. The routine **200** is periodically executed by the CPU **70**, e.g., as part of the CPU's main loop.

[0075] Routine **200** is comprised of decision block **202** which asks whether switch **50** (**FIG. 18**) is closed. If yes, operation proceeds to block **204** to shut off the pump and then returns to the CPU's main loop.

[0076] If switch **50** is not closed (meaning that the water level is above mark **54** (**FIG. 18**)), then operation proceeds to decision block **206** which asks whether switch **52** is closed. If no, then operation returns to the main CPU loop. On the other hand, if sufficient water is in the tub to float magnet actuator **60** to mark **56** and thus close switch **52**, operation will proceed from block **206** to block **208** to turn the pump on. Operation then returns to the main CPU loop.

[0077] CPU **70** also preferably controls one or more of the LED light sources in subassembly **114** to produce, interesting and pleasing lighting effects through the translucent/transparent ramp window **106**. One particularly significant lighting mode in accordance with the invention functions to produce a flame-like flicker behind the ramp window.

[0078] **FIG. 22** shows an exemplary plot of LED brightness vs. time to represent the desired flicker effect for one or more LED's. In accordance with a preferred embodiment of the invention, the LED brightness can be varied as represented in **FIG. 22** by varying the LED on/off time during successive time slots. For example, assume that the time axis in **FIG. 22** is comprised of successive contiguous frame intervals of uniform duration (e.g., 1/62.5 sec.). Then assume that each frame interval is comprised of x successive contiguous time slots (e.g., 128 slots/frame). In accordance with the invention, in order to achieve the desired flicker effect, and LED is held on for a certain number (0-x) of time slots during each frame. **FIG. 23** depicts an exemplary LED operation during three successive frames n, n+1, n+2 in which the on duration of the LED gradually diminishes.

[0079] **FIG. 24** comprises a flow chart depicting an exemplary flicker routine **300** executed by the CPU **70** for controlling the LED brightness to achieve the flicker effect represented in **FIG. 22**. Briefly, for each successive frame, the CPU **70** accesses a new brightness count (block **302**) from a stored data table which brightness count represents the desired LED on duration during the frame. Then, the LED is kept on while the current brightness count is successively decremented until the LED is turned off when the count reaches zero.



[0080] More particularly, at the beginning of each frame, block 302 is executed which initializes a prime slot counter and accesses a table to retrieve a new brightness count for the current frame. Operation then proceeds to decision block 304 which asks whether the current brightness count is equal to zero.

[0081] If yes, then operation proceeds to block 306 which turns off the LED. If the answer to decision block 304 is no, then operation proceeds to block 308 which maintains the LED on and decrements the current brightness count.

[0082] After execution of either block 306 or 308, the time slot count is decremented in block 310. Operation then proceeds to decision block 312 which asks whether the time slot count is equal to zero. If no, then operation loops back to decision block 304. If yes, meaning that the full complement of frame time slots have been completed, operation loops back to block 302.

[0083] From the foregoing explanation of FIG. 24, it should now be understood that during each time frame, the LED will be held on for a certain number of time slots (i.e., 0-x) dependent upon the value of the new brightness count accessed from the table for that frame. In an exemplary embodiment of the invention, each frame has a duration of 1/62.5 seconds and is comprised of 128 time slots. This rate is sufficiently fast that the eye does not perceive that the LED is actually turning on and off but rather perceives a variation in brightness, as represented in FIG. 22 which simulates a fire-like flicker effect.

[0084] CPU 70 preferably also controls additional functions including the operation of a water level indicator LED 76 (FIGS. 14, 20) and a power indicator LED 78 (FIGS. 5, 20) in response to input signals from the first and second reed switches 50, 52, pump on/off switch 74, and power supply 66, respectively. Water level indicator LED 76 is disposed within back cover 80 and adapted to generally illuminate a rear portion 121 (FIGS. 9, 14) of tub 32, and more specifically to illuminate from inside tub 32 water level indicator windows 84, 86 (FIG. 5) so as to allow the user to easily gauge the level of water in tub 32 from outside. Water level indicator LED 76 is electrically coupled to reed switches 50, 52 and is preferably lit when pump dial on/off switch 74 (FIG. 5) is in an "on" position. Water level indicator LED 76 preferably outputs two levels of brightness, and more specifically, will shine in "dim" mode (via pulse width modulation) when pump dial on/off switch 74 is in an "on" position and the water level in tub 32 is at least at tub height mark 56 (FIG. 19a). Conversely, when the water level in tub 32 is lower than height mark 56 (one or none of reed switches 50, 52 being in an "on" mode), then LED 76 will shine in "bright" mode, e.g. a constant 5V output at 20 ms. Alternatively, water level indicator LED 76 will not shine at all if pump dial on/off switch 74 is in an "off" position.

[0085] Power indicator LED 78 (FIGS. 5, 20) preferably operates while CPU 70 is receiving power regardless of the position of dial switch control knobs 74, 120. The operational mode of reed switches 50, 52 directly affects the color of light output from LED 78, e.g. red or green depending on the water level and reed switch position. LED 78 is preferably "on" when pump dial switch 74 is in an "off" position. Moreover, LED lighting sub-assembly 114 is adapted to automatically enter into an "off" mode when pump 36 is shut off either due to low water level or when pump dial switch 74 is in an "off" position.

[0086] CPU 70, power supply 66, water level indicator LED 76 and associated electronics may be integrated on a

printed circuit board (PCB) 67 (FIG. 14). The PCB may be housed in back fountain cover 80 (FIG. 8) which could be provided with an electrical plug 85 (FIG. 5) adapted to accommodate a male quick release connector, as generally shown in FIG. 5. The male quick release connector may be coupled at an opposite end to 12V transformer 68 (not shown).

[0087] The water fountain 30 preferably includes a face plate 132 (FIG. 19a) adapted to securely hold decorative members such as marble and wood decorative members 134, 136 (FIG. 19b). Due to different tolerances of marble and wood members 134, 136, a marble bracket 138 (FIG. 19d) and a spring plate 140 (FIG. 19c) may be utilized during manufacturing to hold marble and wood members 134, 136 tightly against the back side of face plate 132, as generally illustrated in FIG. 1. Face plate 132 may be further adapted to securely hold a logo plate, as generally shown in FIG. 19a.

[0088] The removable ramp window 106 and plenum 34 are preferably made from material(s) capable of withstanding a temperature of up to 160° F. so as to be dishwasher safe. Furthermore, any tinting used on these components should preferably be of sufficiently high quality to withstand alteration in appearance due to continuous lighting exposure from internal LED lighting subassembly 114 and/or from repeated use in automatic dishwashing units.

[0089] While the present invention has been described in detail with regards to a single preferred embodiment, it should be appreciated that various modifications and alternatives can be used without departing from the scope or spirit of the invention. In this regard it is important to note that the invention is not limited to the particular exemplary preferred embodiment described hereinabove. Rather, other applications will become apparent to those skilled in the art. It is, therefore, intended that the present application cover all such modifications and alternatives within the scope of the appended claims and their equivalents.

1. An apparatus configured to pleasingly display a flowing liquid, said apparatus comprising:

- a reservoir for accommodating a volume of liquid;
- a plenum mounted above said reservoir and configured to accumulate a liquid pool;
- a pump operable in a pump-on mode to pump liquid upwardly from said reservoir to form said liquid pool in said plenum;
- a visually open flow pathway sloping downwardly from beneath said plenum and configured to receive liquid from a plenum overflow for return to said reservoir; and
- a controller for alternately defining a pump-on mode and a pump-off mode, said controller including a detector for defining said pump-off mode in response to the liquid level in said reservoir being less than a first height mark and for preventing definition of said pump-on mode unless the liquid level in said reservoir is greater than a second height mark.

2. The apparatus of claim 1, wherein said reservoir includes at least one peripheral window for viewing the reservoir liquid level from outside said reservoir.

3. The apparatus of claim 1, wherein said liquid flow pathway includes a ramp portion adapted to support a substantially smooth sheet liquid flow.

4. The apparatus of claim 3 wherein said ramp portion includes spaced lateral ridges for creating ripples in said sheet liquid flow.

5. The apparatus of claim 1 wherein said flow pathway includes a substantially convex surface portion adapted to support a substantially smooth sheet liquid flow.

6. The apparatus of claim 1 wherein said flow pathway includes a substantially concave surface portion adapted to support a substantially smooth sheet liquid flow.

7. The apparatus of claim 1 wherein said detector includes a first switch mounted proximate to said first height mark and a second switch mounted proximate to said second height mark.

8. The apparatus of claim 7 wherein said detector further includes at least one switch actuator configured to float proximate to the liquid level in said reservoir.

9. The apparatus of claim 8 wherein said controller is responsive to said first and second switches to define said pump-off mode when said liquid falls below said first height mark and to subsequently define said pump-on mode only after said level rises above said second height mark.

10. The apparatus of claim 8 wherein said switch actuator comprises a magnet.

11. The apparatus of claim 10 wherein at least one of said switches is responsive to a magnetic field proximate thereto.

12. The apparatus of claim 1 further comprising a housing having wall portions substantially converging upwardly above said reservoir.

13. The apparatus of claim 12 wherein said housing wall portions are substantially planar and define interior and exterior surfaces; and wherein

said reservoir and said wall portion interior surfaces are sealed to prevent liquid leakage therebetween.

14. The apparatus of claim 13 further including at least one decorative panel mounted on a wall portion exterior surface.

15. The apparatus of claim 1 wherein said liquid flow pathway includes a light transmissive portion.

16. The apparatus of claim 15 further comprising at least one light source for illuminating said liquid flow through said light transmissive portion.

17. The apparatus of claim 16 wherein said at least one light source includes a light emitting diode (LED) mounted in said reservoir and sealed in a waterproof housing.

18. The apparatus of claim 15 further comprising a plurality of light sources adapted to illuminate said liquid flow in a variety of colors through said light transmissive portion.

19. The apparatus of claim 1 further including at least one light source energizable to illuminate said liquid flow pathway; and

a controller for variably energizing said light source to simulate a flame flicker.

20. An apparatus configured to pleasingly display a flowing liquid, said apparatus comprising:

a reservoir for accommodating a volume of liquid;

a visually open flow pathway having an upstream end and sloping downwardly to a downstream end proximate to said reservoir;

a pump operable to pump liquid upwardly from said reservoir to said upstream end; and

a controller for switching said pump off in response to the liquid level in said reservoir falling below a first height mark and for preventing resumption of pump operation unless the liquid level in said reservoir rises above a second height mark greater than first height mark.

21. The apparatus of claim 20 wherein said reservoir includes at least one peripheral window for viewing the reservoir liquid level from outside said reservoir.

22. The apparatus of claim 20 wherein said controller includes first and second level detectors respectively mounted adjacent to said first and second height marks.

23. The apparatus of claim 22 further including an actuator configured to float proximate to the surface of the liquid in said reservoir; and wherein

each of said first and second detectors is responsive to the proximity of said actuator.

24. The apparatus of claim 22 wherein said actuator comprises a magnet and each of said first and second detectors comprises a reed switch.

25. The apparatus of claim 22 further including at least one substantially vertically oriented guide member mounted in said reservoir;

a substantially toroidal float mounted for vertical movement along said guide member; and wherein

said actuator is mounted on said float.

26. The apparatus of claim 25 wherein said actuator comprises a magnet and each of said first and second detectors comprises a reed switch.

27. The apparatus of claim 26 wherein said guide member comprises at least one tubular member; and wherein

at least one of said reed switches is mounted in said tubular member.

28. An apparatus configured to pleasingly display a flowing liquid, said apparatus comprising:

a liquid reservoir;

a pump coupled to said reservoir for pumping liquid upstream to a plenum configured to form a substantially still liquid pool, said substantially still liquid pool adapted to overflow onto an upstream end of a visually open flow pathway configured to return said liquid overflow to said reservoir; and

a pump controller adapted to prevent said pump from running dry.

29. The apparatus of claim 28 wherein said reservoir includes at least one peripheral window for viewing the reservoir liquid level from outside said reservoir.

30. The apparatus of claim 28 wherein said flow pathway includes a ramp portion adapted to support a substantially smooth sheet liquid flow.

31. The apparatus of claim 30 wherein said ramp portion includes spaced lateral ridges for creating ripples in said liquid sheet flow.

32. The apparatus of claim 28 wherein said flow pathway includes a substantially convex surface portion and a concave surface portion adapted to support a substantially smooth sheet liquid flow.