



US00D928740S

(12) **United States Design Patent**
Klein

(10) **Patent No.:** **US D928,740 S**

(45) **Date of Patent:** **** Aug. 24, 2021**

(54) **TOUCHSCREEN PUSH-TO-TALK BUTTON**

(71) Applicant: **Klein Electronics, Inc.**, Escondido, CA (US)

(72) Inventor: **Richard Klein**, Escondido, CA (US)

(73) Assignee: **KLEIN ELECTRONICS, INC.**, Escondido, CA (US)

(**) Term: **15 Years**

(21) Appl. No.: **29/703,982**

(22) Filed: **Aug. 30, 2019**

(51) **LOC (13) Cl.** **14-03**

(52) **U.S. Cl.**

USPC **D14/218**

(58) **Field of Classification Search**

USPC D14/388, 218, 454, 299, 496, 129, 371, D14/382, 203.1, 203.3, 203.6; D21/333, D21/566; D13/168

CPC G06F 1/1605; G06F 3/01; G06F 3/0308; G06F 3/033; G06F 3/0338; G06F 3/03543; G06F 3/038; G06F 3/14; H04M 2215/2093; A63F 13/24; A63F 13/213; A63F 13/214; A63F 13/02; A63F 13/20

See application file for complete search history.

(56) **References Cited**

U.S. PATENT DOCUMENTS

D121,962 S	8/1940	Meuer
D180,453 S	6/1957	Parker et al.
D201,244 S	6/1965	Tateisi
3,280,273 A	10/1966	Flygstad et al.
3,984,645 A	10/1976	Kresch
4,289,938 A	9/1981	Zichy et al.
4,335,281 A	6/1982	Scott et al.

(Continued)

OTHER PUBLICATIONS

2 Way Radio Parts Product Image PMMN4050A (1 pg) (Accessed 2018).

(Continued)

Primary Examiner — Marie D. Fast Horse

(74) *Attorney, Agent, or Firm* — Wilson Sonsini Goodrich & Rosati

(57) **CLAIM**

The ornamental design for a touchscreen push-to-talk button, as shown and described.

DESCRIPTION

FIG. 1 is a top, front perspective view of a touchscreen push-to talk button, showing my new design, in a condition for use engaged with the top connector;

FIG. 2 is a front elevational view thereof;

FIG. 3 is a back elevational view thereof;

FIG. 4 is a left side elevational view thereof;

FIG. 5 is a right side elevational view thereof;

FIG. 6 is a top plan view thereof;

FIG. 7 is a bottom plan view thereof;

FIG. 8 is a top front perspective view of the touchscreen push-to talk button shown in an unplugged condition, disengaged with the top connector;

FIG. 9 is a front elevational view thereof;

FIG. 10 is a back elevational view thereof;

FIG. 11 is a left side elevational view thereof;

FIG. 12 is a right side elevational view thereof;

FIG. 13 is a top plan view thereof; and,

FIG. 14 is a bottom plan view thereof.

The broken line consisting of unevenly sized dashes located on the boot portion defines the boundary of the claim, which extends to the boundary line but does not include the boundary line. The broken lead line consisting of unevenly sized dashes shown between the disengaged top connector portion to the port in FIGS. 8-14 forms no part of the claim; while all other broken lines in the drawings depict portions of the touchscreen push-to talk button that form no part of the claimed design.

1 Claim, 14 Drawing Sheets

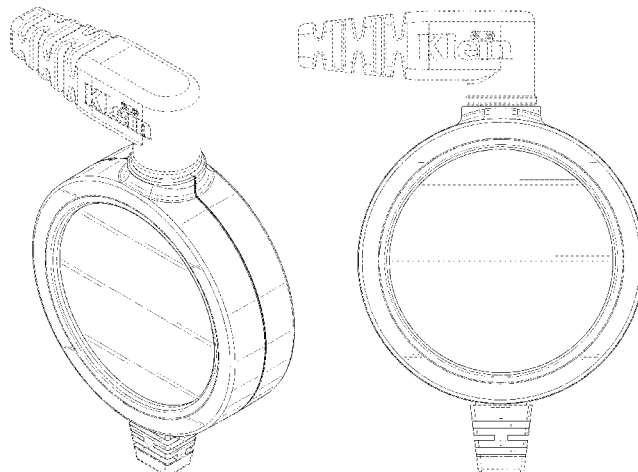

(56)

References Cited

U.S. PATENT DOCUMENTS

- 4,420,657 A 12/1983 Larkin
4,499,593 A 2/1985 Antle et al.
4,754,484 A 6/1988 Larkin et al.
4,893,344 A 1/1990 Traegardh et al.
D307,579 S * 5/1990 Layne D13/137.3
4,926,961 A 5/1990 Gattety et al.
D309,305 S 7/1990 Von Hall et al.
D311,521 S 10/1990 Jonsson et al.
D314,964 S * 2/1991 Chung D14/188
4,993,065 A 2/1991 Chiou
D316,550 S 4/1991 Sogabe
5,019,767 A 5/1991 Shirai et al.
D327,265 S 6/1992 Jasey
D330,192 S 10/1992 Holland et al.
D333,460 S 2/1993 Huang
5,210,792 A 5/1993 Kajihara
D339,355 S 9/1993 Burris et al.
D344,522 S * 2/1994 Taniguchi D14/218
D351,375 S * 10/1994 Nagele D13/171
5,446,788 A 8/1995 Lucey et al.
D366,486 S 1/1996 Runquist et al.
D371,133 S 6/1996 Andrea
D371,793 S * 7/1996 Patton D14/218
D374,011 S 9/1996 Baxter
5,625,171 A 4/1997 Marshall
D383,115 S 9/1997 Nagele et al.
D384,958 S 10/1997 Shudo
D388,053 S 12/1997 Robertson, Jr. et al.
D391,943 S * 3/1998 Han D14/356
D391,944 S * 3/1998 Han D14/356
D401,902 S 12/1998 Falls et al.
D409,621 S 5/1999 Andrea
D413,574 S 9/1999 Goto
D416,559 S * 11/1999 Hoyt D14/217
D418,482 S * 1/2000 MacKay D13/160
D430,139 S 8/2000 Peters et al.
6,097,827 A 8/2000 Yang
D431,030 S 9/2000 Yoon
6,122,369 A 9/2000 Hwang et al.
6,178,251 B1 1/2001 Luchs et al.
D442,570 S * 5/2001 Arjomand D14/160
6,233,167 B1 5/2001 Chen et al.
D445,416 S 7/2001 Glezerman
6,272,362 B1 8/2001 Wang
D448,006 S * 9/2001 Lee D13/133
D454,546 S * 3/2002 MacKay D13/160
D458,919 S * 6/2002 Arjomand D14/218
6,405,056 B1 6/2002 Altschul et al.
D461,476 S * 8/2002 Evers D14/341
6,438,248 B1 8/2002 Kamimura et al.
D463,399 S 9/2002 Konomi et al.
D463,787 S * 10/2002 Beraut D14/218
D465,476 S * 11/2002 Golding D14/223
D465,477 S * 11/2002 Beraut D14/218
D469,753 S 2/2003 Andre et al.
6,519,475 B1 2/2003 Kim
D471,890 S 3/2003 Clarkson
D473,217 S 4/2003 Rivera
6,625,293 B1 9/2003 Nageno et al.
D481,389 S * 10/2003 Owen D14/358
D482,694 S * 11/2003 Chen D14/385
D486,819 S 2/2004 Wilson
D499,086 S * 11/2004 Polito D14/218
D500,485 S 1/2005 Deguchi
D506,994 S 7/2005 Olson et al.
D507,569 S * 7/2005 Tagliabue D14/356
D510,082 S 9/2005 Olson et al.
D511,157 S 11/2005 Johnson
6,961,440 B1 11/2005 Schlaegel et al.
D512,437 S * 12/2005 Tierney D14/203.6
D512,709 S * 12/2005 Hemer D14/206
D515,516 S * 2/2006 Mayo D13/171
D516,082 S * 2/2006 Lewis D14/203.6
D519,454 S * 4/2006 Christianson D13/133
D519,504 S * 4/2006 Tagliabue D14/356
D524,295 S * 7/2006 Jacobson D14/218
D527,017 S * 8/2006 Kim D14/203.6
D531,159 S * 10/2006 Park D14/203.3
7,139,590 B2 11/2006 Liu et al.
D533,865 S 12/2006 Wittenbrock et al.
D539,304 S * 3/2007 Lee D14/203.6
D542,234 S * 5/2007 Shimizu D13/168
D542,280 S 5/2007 Taylor
D548,728 S 8/2007 Yoshiyama
D550,297 S * 9/2007 Luciano, Jr. D13/171
D550,299 S * 9/2007 Luciano, Jr. D13/171
D550,301 S * 9/2007 Luciano, Jr. D21/369
D550,305 S * 9/2007 Luciano, Jr. D13/174
D556,268 S * 11/2007 Luciano, Jr. D13/171
D558,735 S 1/2008 Carr et al.
D562,317 S 2/2008 Lagerberg et al.
D563,395 S 3/2008 Pitcher et al.
D565,557 S 4/2008 Kaneda
D569,841 S 5/2008 Chung et al.
D574,834 S * 8/2008 Chen D14/432
D575,228 S 8/2008 So
D575,768 S 8/2008 Wang
D578,507 S 10/2008 Ando
D578,508 S 10/2008 Wang
D583,362 S * 12/2008 Hsu D14/205
D587,678 S 3/2009 Yuyama
D588,099 S 3/2009 Yuyama
D588,110 S 3/2009 Darbut
D588,584 S 3/2009 Park et al.
D593,548 S 6/2009 Von Meiss et al.
D596,622 S * 7/2009 Lee D14/218
D598,008 S * 8/2009 Shimizu D13/168
D601,564 S * 10/2009 Maeno D14/400
D606,980 S 12/2009 Bradford
D607,852 S * 1/2010 Riede D13/174
D607,875 S 1/2010 Pedersen, II
7,664,540 B2 2/2010 Tsai et al.
D614,166 S * 4/2010 Brickstad D14/218
D616,419 S 5/2010 Suwalski et al.
D619,124 S 7/2010 Clay
D620,482 S 7/2010 Chen
7,778,435 B2 8/2010 Smith et al.
D632,281 S * 2/2011 Hoehn D14/218
D638,001 S * 5/2011 Nakhjiri D14/242
D643,414 S * 8/2011 Lee D14/223
RE42,686 E * 9/2011 Shimizu D13/168
D645,028 S * 9/2011 Pescetto D14/225
D653,219 S 1/2012 Woytowitz et al.
D654,867 S 2/2012 Hueppe
D676,812 S 2/2013 Smith et al.
D682,808 S 5/2013 Fletcher et al.
D682,835 S * 5/2013 Daniel D14/433
D683,251 S * 5/2013 Dumas D10/104.2
8,457,343 B2 6/2013 Zhu
D691,563 S 10/2013 Yong et al.
D698,316 S 1/2014 Yong et al.
D698,750 S 2/2014 Yoon
D709,504 S * 7/2014 Breines D14/433
D712,873 S 9/2014 Krauss et al.
D712,874 S 9/2014 Gauger, Jr. et al.
D716,257 S 10/2014 Sarkoyan
D723,476 S * 3/2015 Aromin D13/160
D726,147 S 4/2015 Tran et al.
D726,831 S 4/2015 Lee et al.
D730,873 S * 6/2015 Petterson D14/218
D734,298 S 7/2015 Tatkon-Coker et al.
D739,377 S 9/2015 Yeom et al.
D743,381 S 11/2015 Pi et al.
D746,260 S 12/2015 Goransson
D753,626 S 4/2016 Tran
D754,637 S 4/2016 Harper
D768,114 S * 10/2016 Hou D14/218
D770,421 S * 11/2016 Rettersen D14/218
D776,637 S 1/2017 Chen
D777,138 S 1/2017 Fletcher et al.
D778,873 S 2/2017 Chen et al.
D783,571 S * 4/2017 Mizrahi D14/218
D784,287 S * 4/2017 Murray D14/203.6
D786,193 S * 5/2017 Akana D13/108

(56)

References Cited

U.S. PATENT DOCUMENTS

D791,107 S * 7/2017 Goltche D14/225
 D793,360 S 8/2017 Birger
 D793,964 S * 8/2017 Aromin D13/160
 D793,995 S 8/2017 Nakagawa
 D796,484 S * 9/2017 Chen D14/218
 D804,533 S * 12/2017 Mangum D14/496
 D807,300 S 1/2018 Lambie et al.
 D807,832 S 1/2018 Lambie et al.
 D810,086 S * 2/2018 Xie D14/433
 D810,087 S * 2/2018 Xie D14/433
 D810,724 S 2/2018 Czaniecki et al.
 D817,302 S 5/2018 Birath et al.
 D821,999 S 7/2018 Guo et al.
 D823,280 S 7/2018 Guilfoyle et al.
 D824,875 S 8/2018 Czaniecki et al.
 D829,714 S * 10/2018 Robinson D14/356
 D831,189 S * 10/2018 Fang D24/107
 D835,589 S * 12/2018 Zhang D13/171
 D840,954 S 2/2019 Wu
 D841,619 S 2/2019 Klein
 D842,839 S 3/2019 Klein
 D848,954 S 5/2019 Chadbourne et al.
 D853,982 S * 7/2019 Lu D14/155
 D855,570 S * 8/2019 Vladimirovich D13/133
 D858,463 S * 9/2019 Nien D13/168
 D862,421 S 10/2019 Arimoto
 D863,256 S * 10/2019 Lindof D14/217
 D864,163 S * 10/2019 Lindof D14/217
 D866,485 S * 11/2019 Aromin D13/160
 D867,335 S 11/2019 Lee et al.
 D870,057 S 12/2019 Gassner
 D875,072 S 2/2020 Yao et al.
 D875,718 S 2/2020 Lee et al.
 D881,162 S * 4/2020 Zhu D14/218
 D890,752 S * 7/2020 Huang D14/358
 D902,162 S * 11/2020 Koo D13/171
 D906,979 S * 1/2021 Chen D13/146
 D907,007 S * 1/2021 Chen D14/218
 D909,316 S * 2/2021 Ayers D13/174
 D910,598 S * 2/2021 Kass G06F 1/1656
 D14/218
 2002/0012441 A1 1/2002 Matsunaga et al.
 2002/0096391 A1 7/2002 Smith et al.
 2002/0181729 A1 12/2002 Smith
 2004/0097273 A1 5/2004 Chiang et al.

2008/0026700 A1 * 1/2008 Smith H04B 1/44
 455/90.2
 2008/0167092 A1 7/2008 Ueda et al.
 2009/0128427 A1 5/2009 Nawa et al.
 2011/0119773 A1 5/2011 Woytowitz
 2012/0018595 A1 1/2012 Berry et al.
 2012/0077549 A1 3/2012 Gibbons
 2012/0155803 A1 6/2012 Benjamin et al.
 2013/0128476 A1 5/2013 Liou et al.
 2014/0138150 A1 5/2014 Huang
 2015/0023518 A1 * 1/2015 Mizrahi H04B 1/0343
 381/74
 2016/0142808 A1 5/2016 Monahan et al.
 2017/0118003 A1 4/2017 Qu et al.
 2017/0295419 A1 10/2017 Poulsen et al.
 2019/0342664 A1 11/2019 Payne et al.

OTHER PUBLICATIONS

Audio Adapter for Motorola Radio XPR 6350,XPR 6380,XPR 6550,XPR 6580,XPR 7350,XPR 7550,XPR 7380,XPR 7580,APX 3000,APX 1000,APX 900, with 2 Audio Jack, Gold-Plated Pogo Pin, Rugged Construction (5 pgs) (Accessed 2018).
 Co-pending U.S. Appl. No. 29/598,417, filed Mar. 24, 2017.
 Co-pending U.S. Appl. No. 29/598,418, filed Mar. 24, 2017.
 Co-pending U.S. Appl. No. 29/598,419, filed Mar. 24, 2017.
 Co-pending U.S. Appl. No. 29/598,420, filed Mar. 24, 2017.
 Co-pending U.S. Appl. No. 29/605,412, filed May 25, 2017.
 Co-pending U.S. Appl. No. 29/647,918, filed May 31, 2018.
 Co-pending U.S. Appl. No. 29/672,295, filed Dec. 4, 2018.
 U.S. Appl. No. 29/598,416 Office Action dated Mar. 26, 2018.
 U.S. Appl. No. 29/598,417 Office Action dated Mar. 27, 2018.
 U.S. Appl. No. 29/598,418 Office Action dated Mar. 29, 2018.
 U.S. Appl. No. 29/598,419 Office Action dated Mar. 29, 2018.
 U.S. Appl. No. 29/598,420 Office Action dated Mar. 27, 2018.
 U.S. Appl. No. 29/598,421 Office Action dated Mar. 29, 2018.
 Waveband WX-8004-E5 Series Rugged Heavy Duty Public Safety Microphone for Harris Ma/Com XG-100 P WB#WX-8004-E5 (4 pgs.) (Accessed 2018).
 Klein 3.5mm Adapter for XP5s and XP8, online, no post date, URL: <https://store.soninntech.com/products/adapter-for-xp5s-and-xp8>, retrieved Apr. 23, 2020.
 U.S. Appl. No. 29/647,918 Ex Parte Quayle dated Apr. 29, 2020.

* cited by examiner

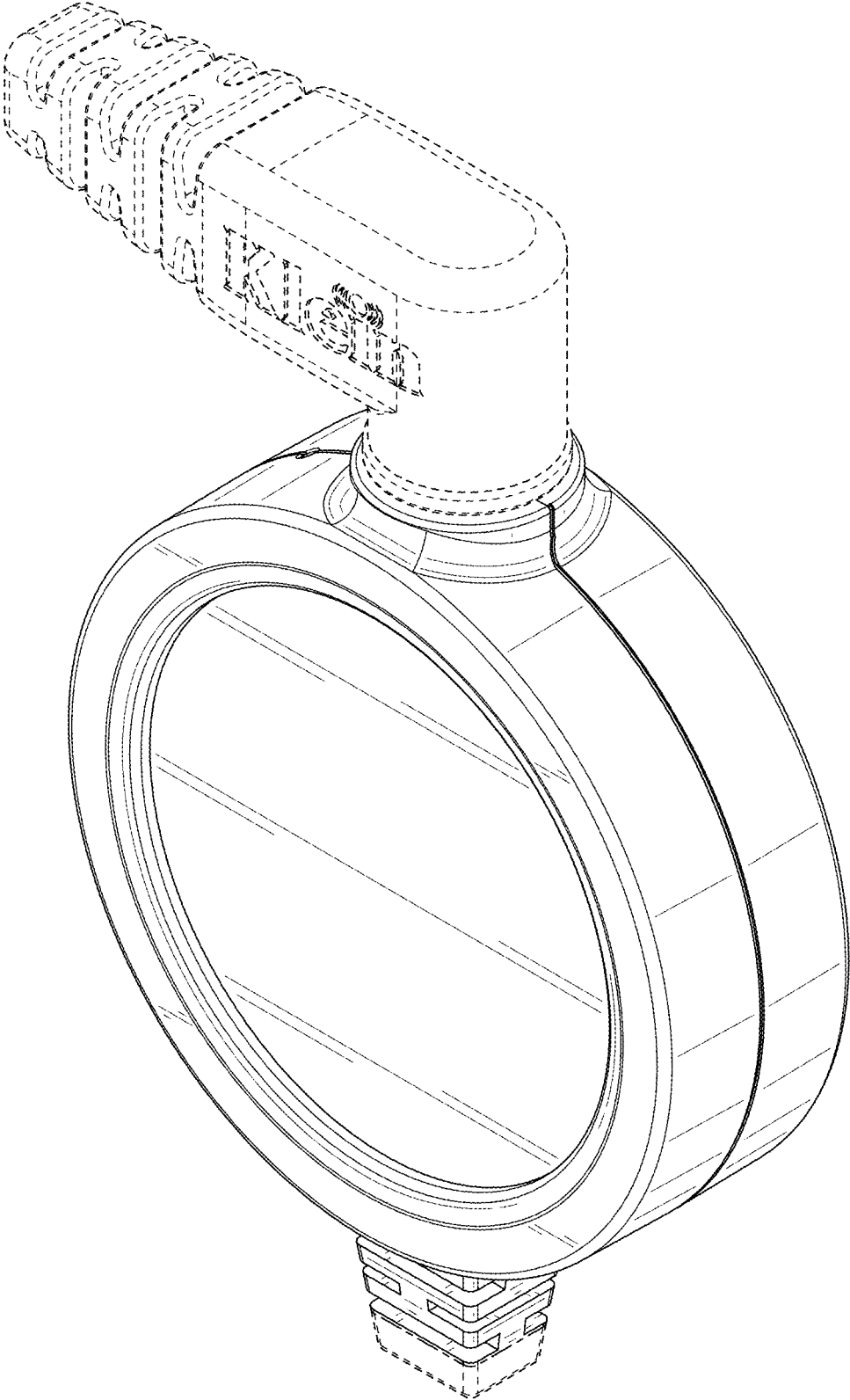

FIG. 1

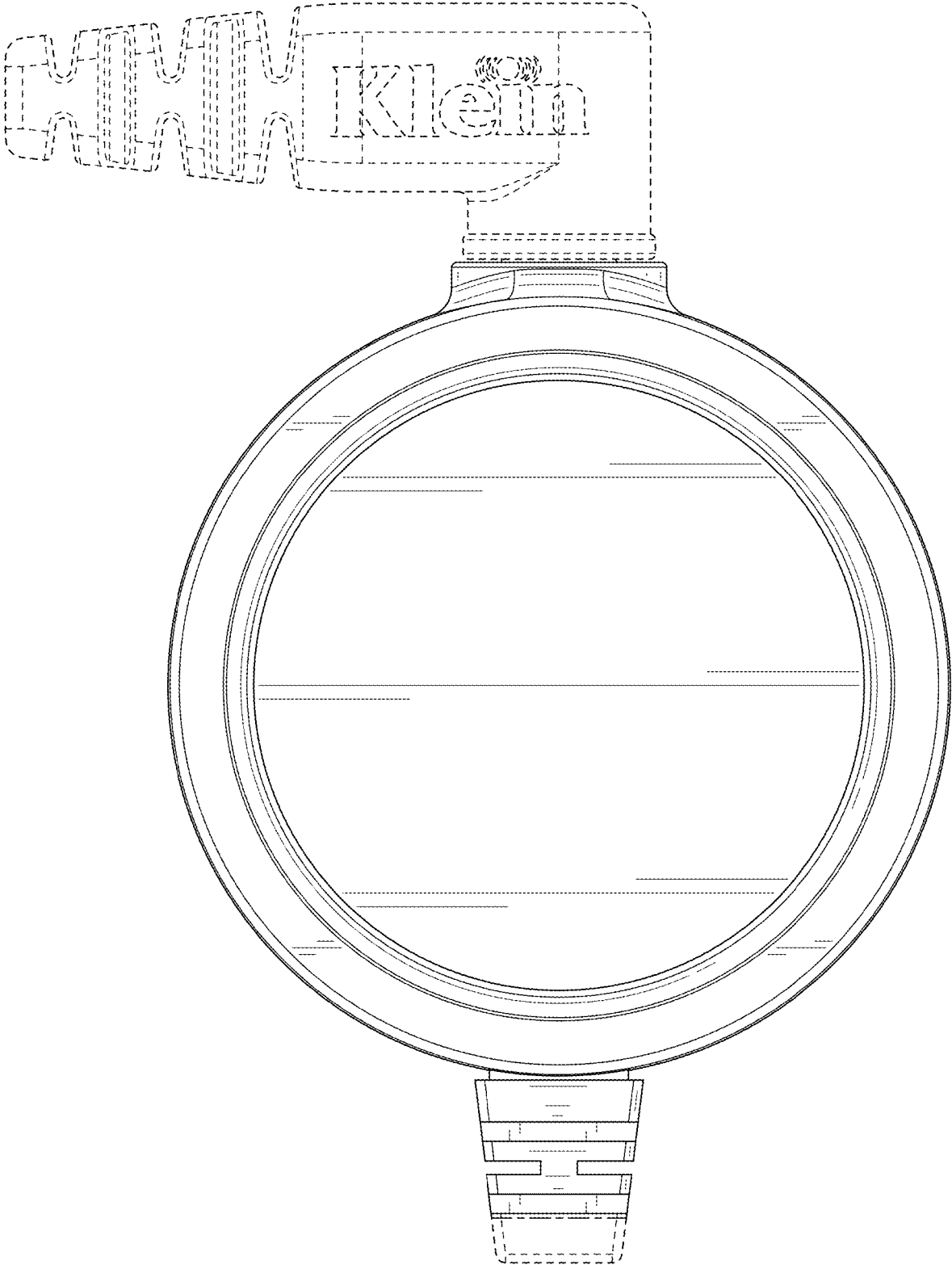

FIG. 2

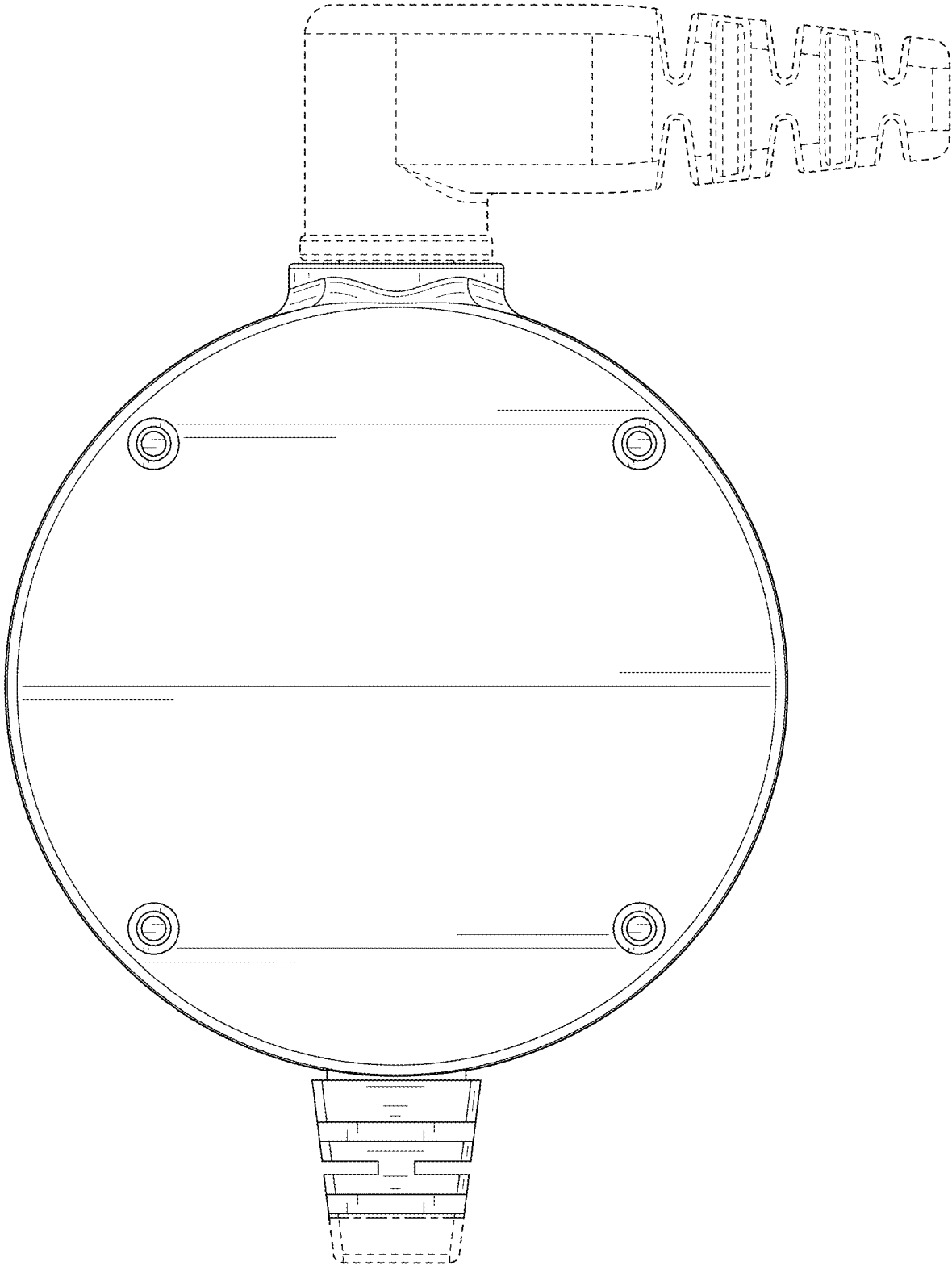

FIG. 3

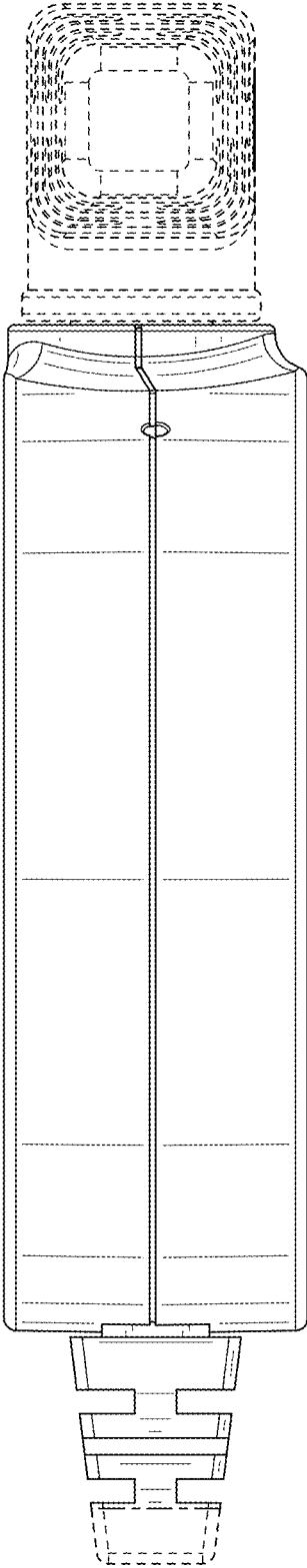

FIG. 4

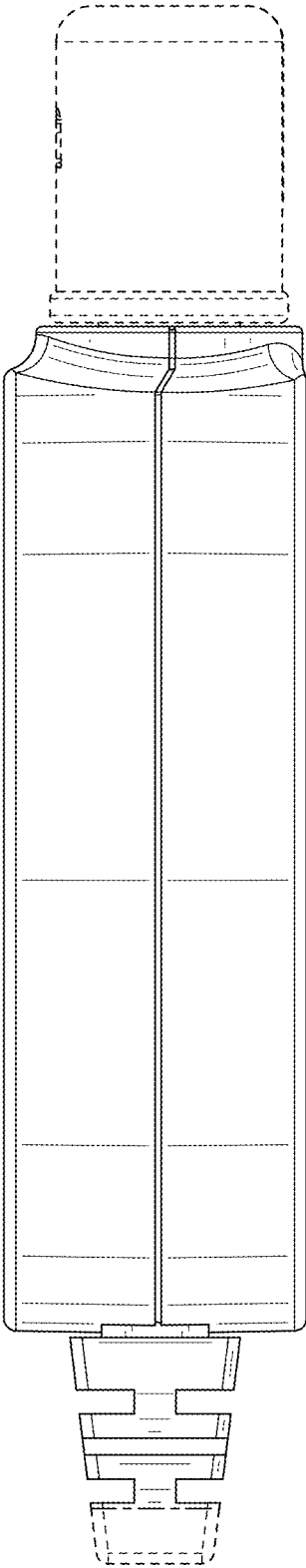

FIG. 5

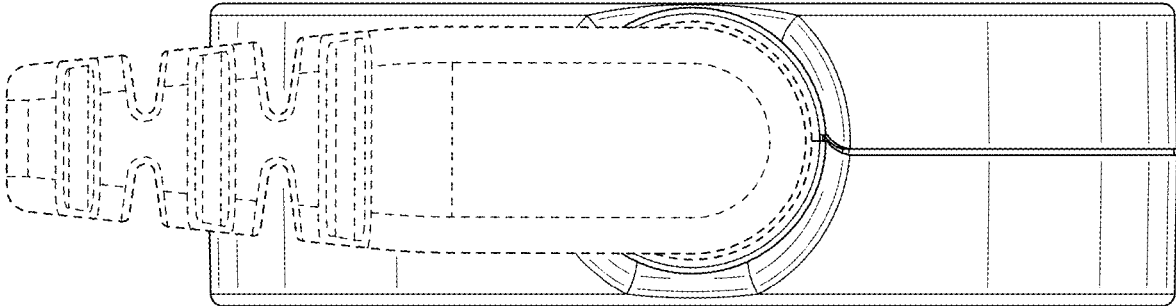

FIG. 6

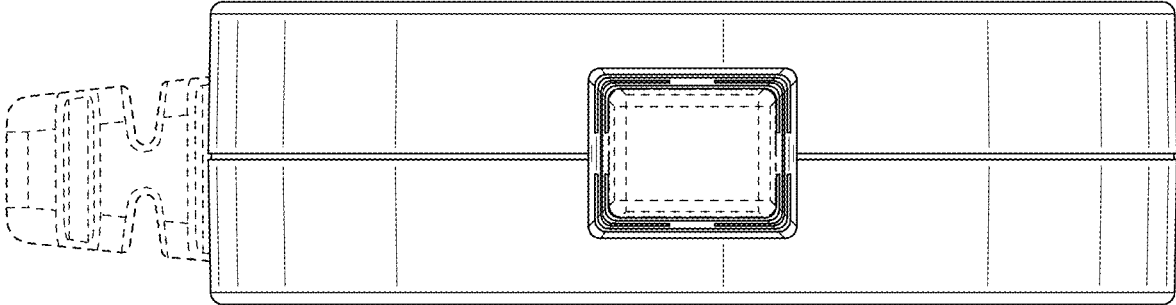

FIG. 7

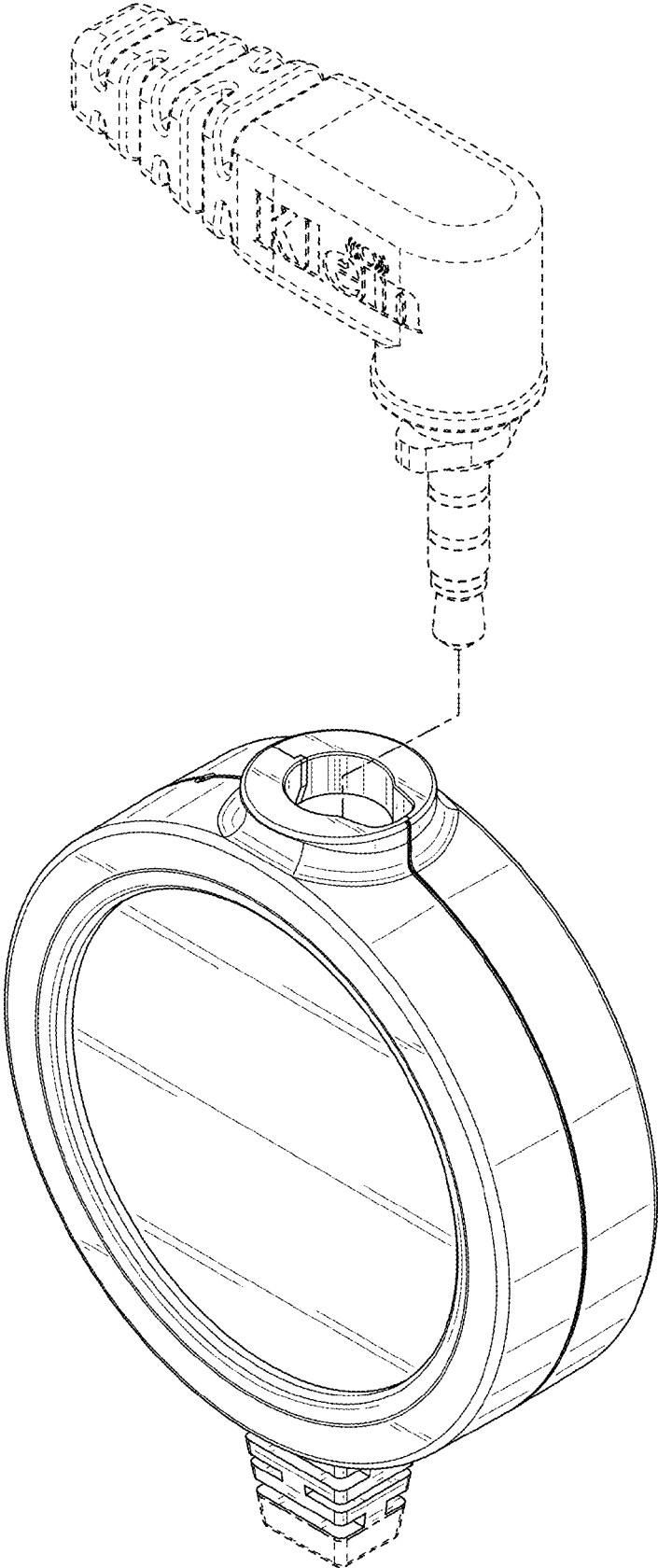

FIG. 8

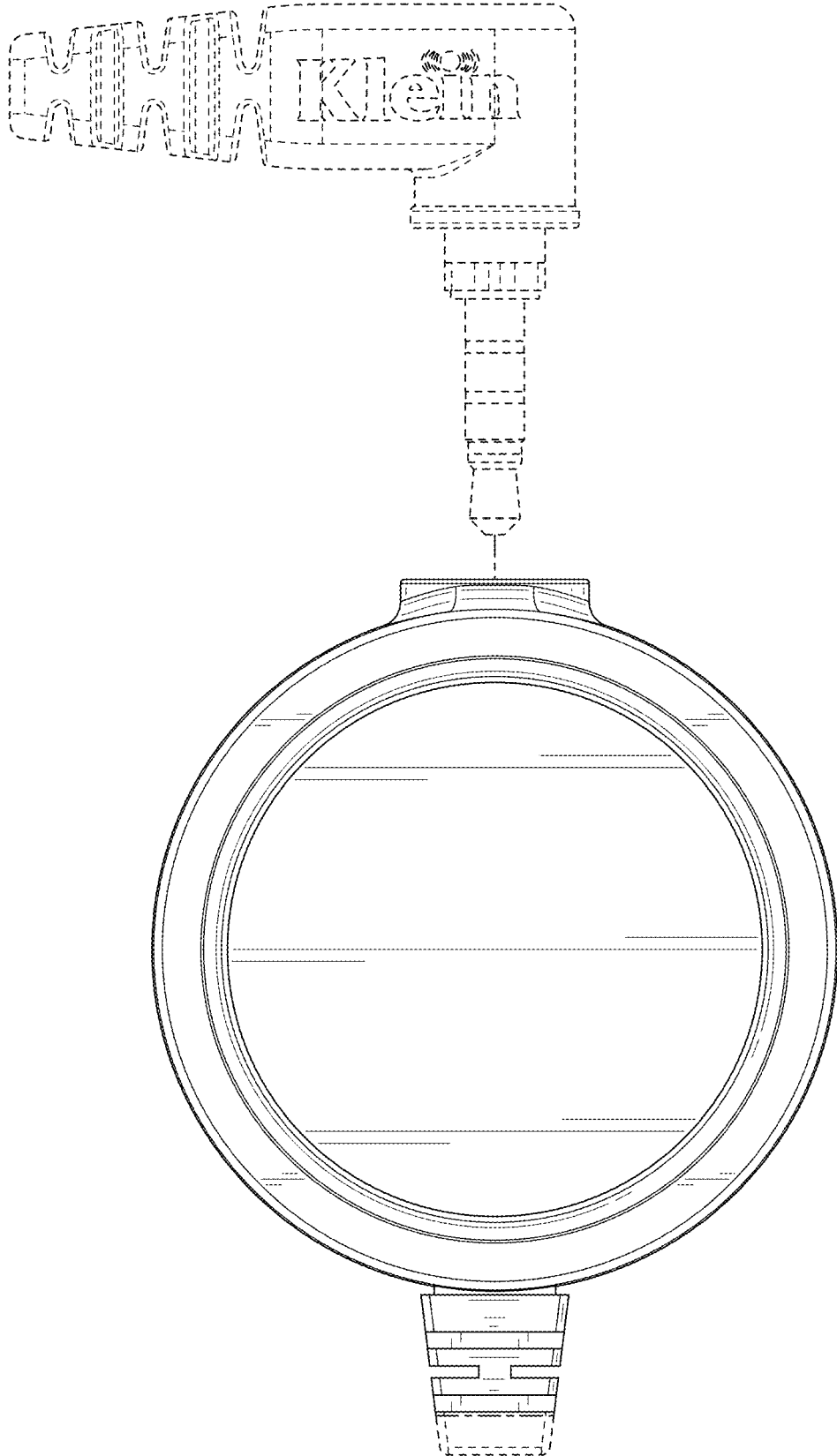

FIG. 9

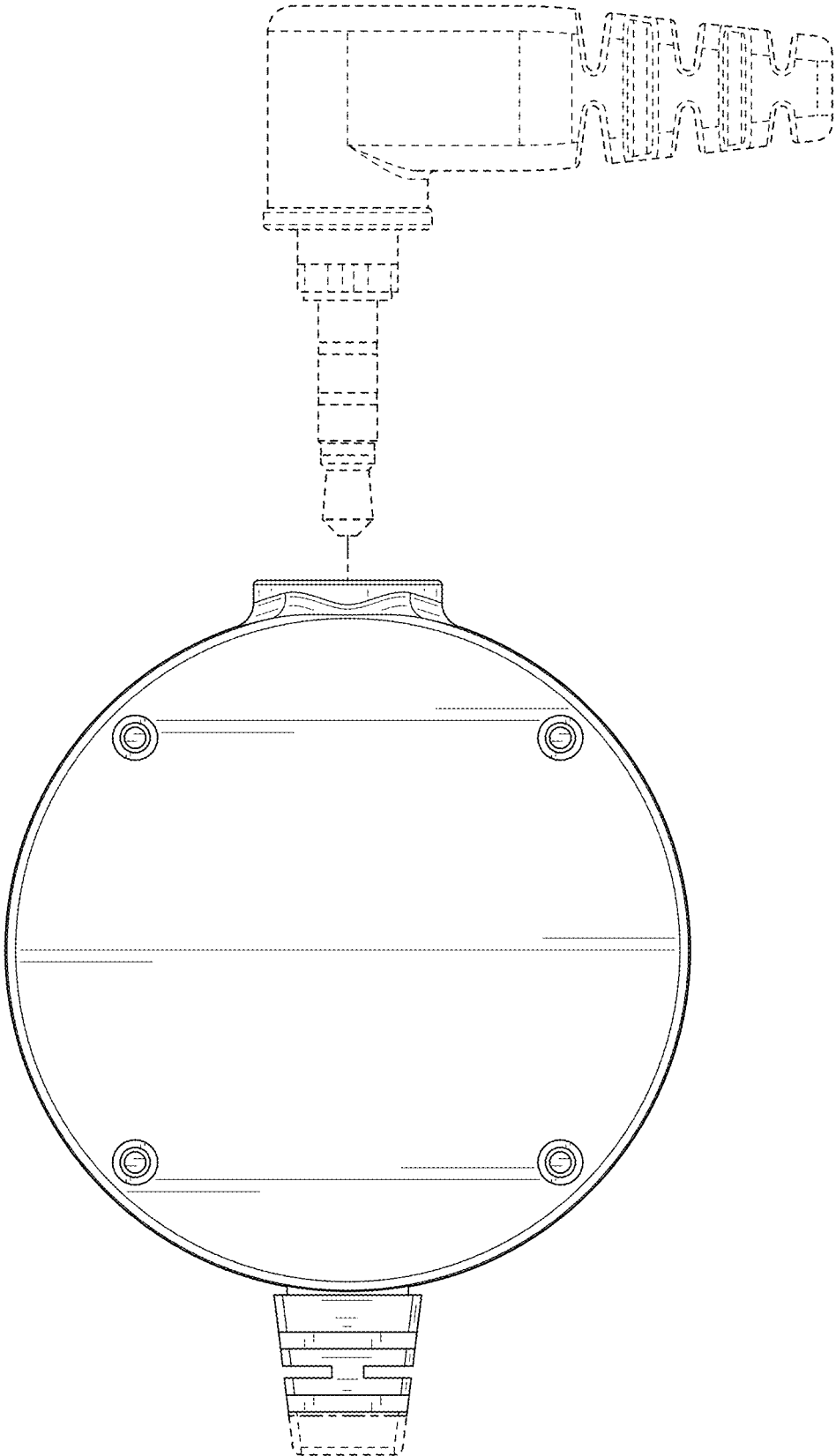

FIG. 10

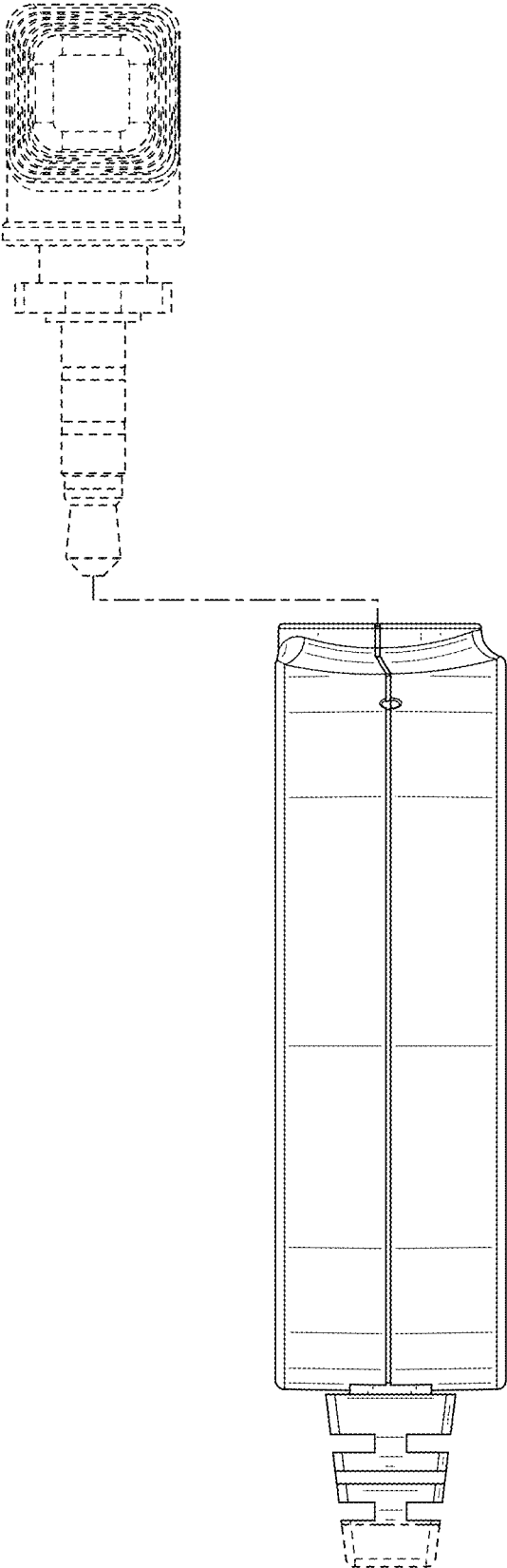

FIG. 11

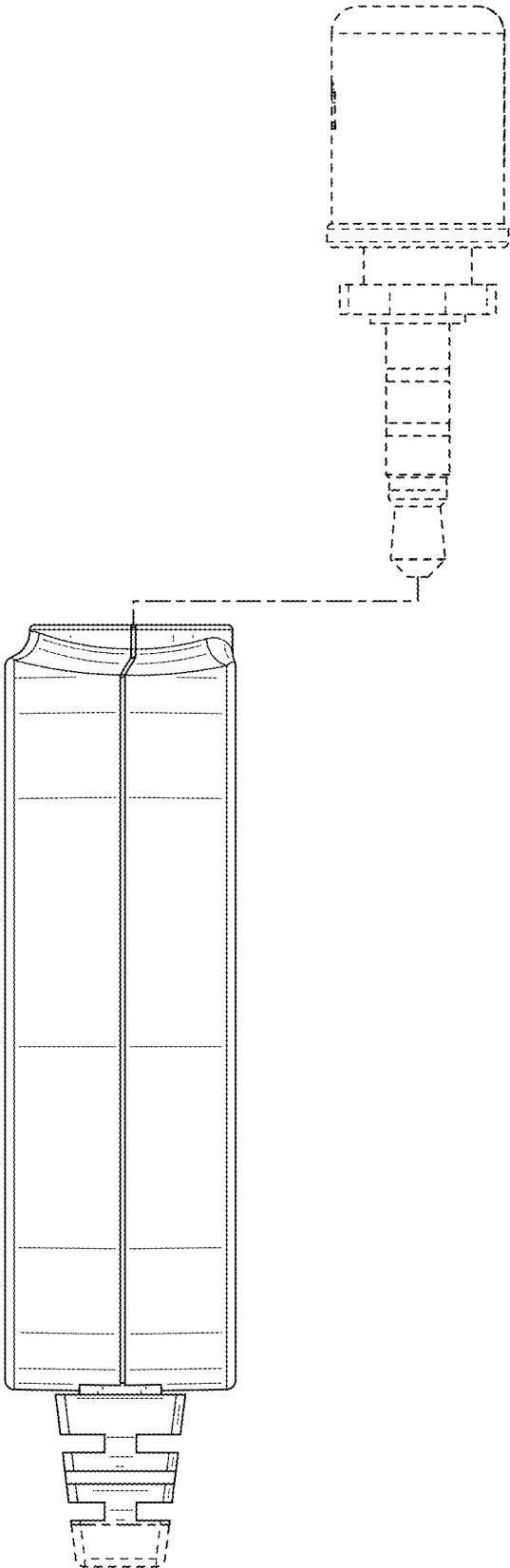

FIG. 12

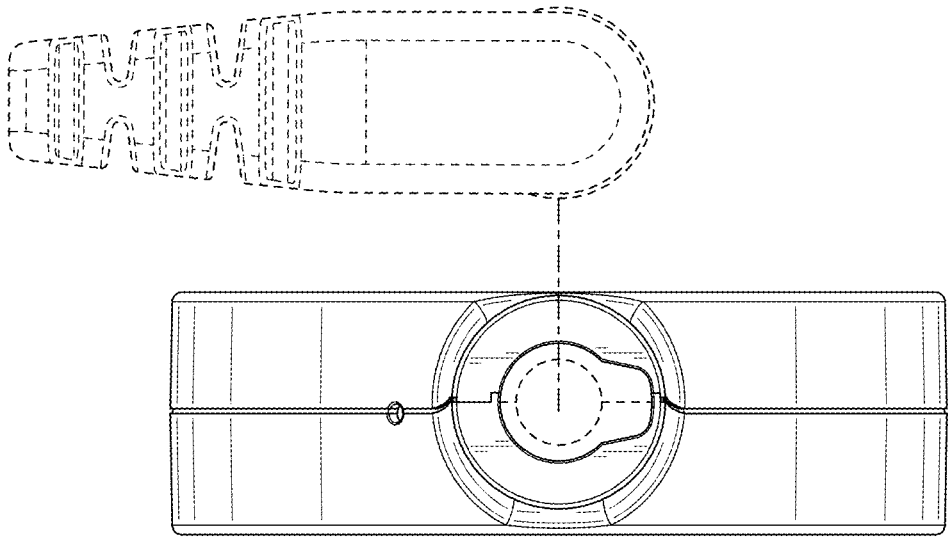

FIG. 13

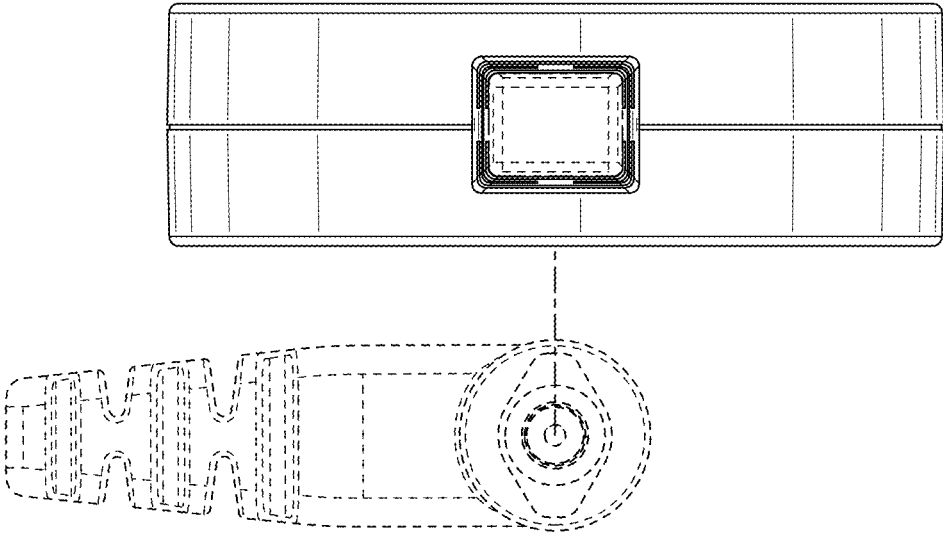

FIG. 14