

(19)
(12)

(KR)
(Y1)

(51) 。 Int. Cl. 7
F16L 23/00

(45)
(11)
(24)

2001 12 13
20 - 0255556
2001 11 14

(21) 20 - 2001 - 0026738
(22) 2001 09 01

(73) 326 1214 306

(72) 326 1214 306

(74)

:
가 :

(54)

1 ,

2 1 A - A ,

3 ,

4 3 B - B ,

5 3 C ,

6 ,

7 .

<

1 : 1a :

1b : 3 :

5 : 7 :

9 : 10 :

11 : 12 :

20 : 30 :

31 : 40 :

50 : 60 :

100 : 200 :

300 :

가 가

1 (9) (1) , 2 1 A - A (1) 1 2 (3)
(3) (1) (1a) (1b) (5) (7) (1)

2~3 (3) (5) (1) (5) (7) (1)
(9)

가 (9) 가 (1)
(9)
(1)

2 (10);

(10) (20);
(40); (20) (30); (20)
(10) (100)
(20) (20)
(20) (40) (50) (50) (60)

(10) 1 ,

(Lock Seam) , (10)

(100) , (40)

(10) , (CR - CSP)

(40) (10) 가 , (C
R - CSP)

가 .

가

가

가 .

가

(57)

1.

(10);

(10)

(20);

(20)

(30);

(20)

(40);

2.

1 , (10)

3.

1 , (20)

4.

1 , (20) (40) (50) (50) (60) (

1

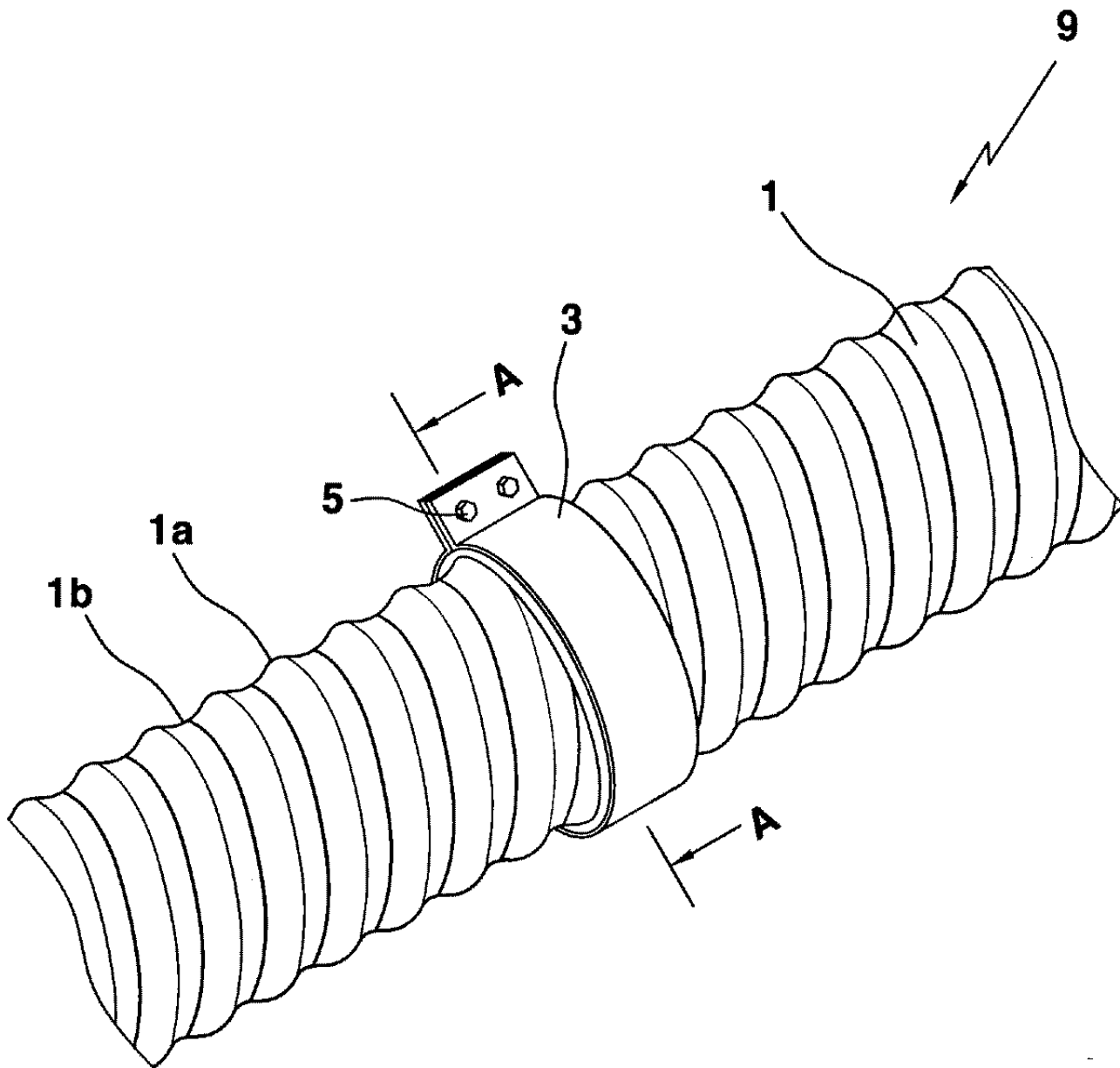

2

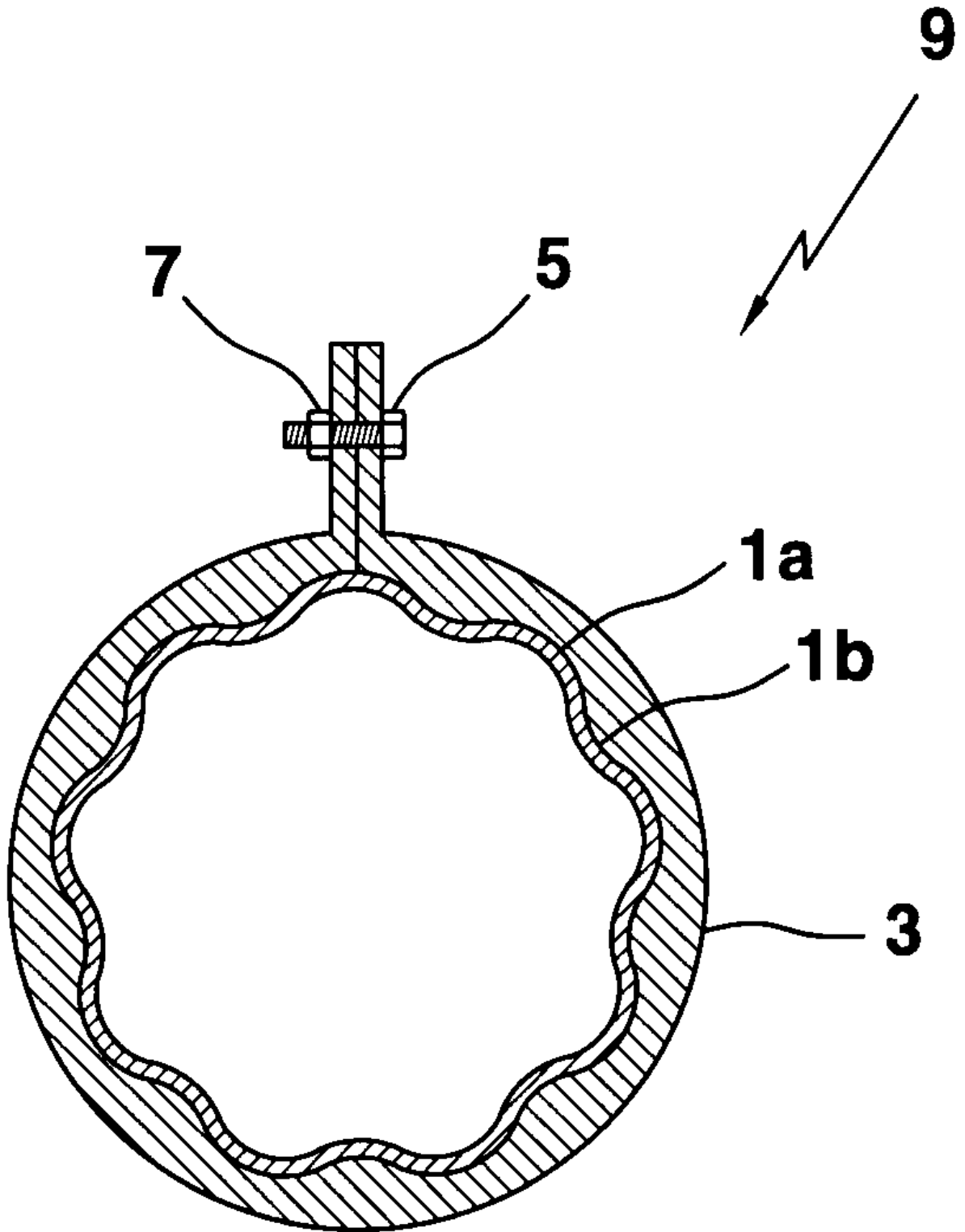

3

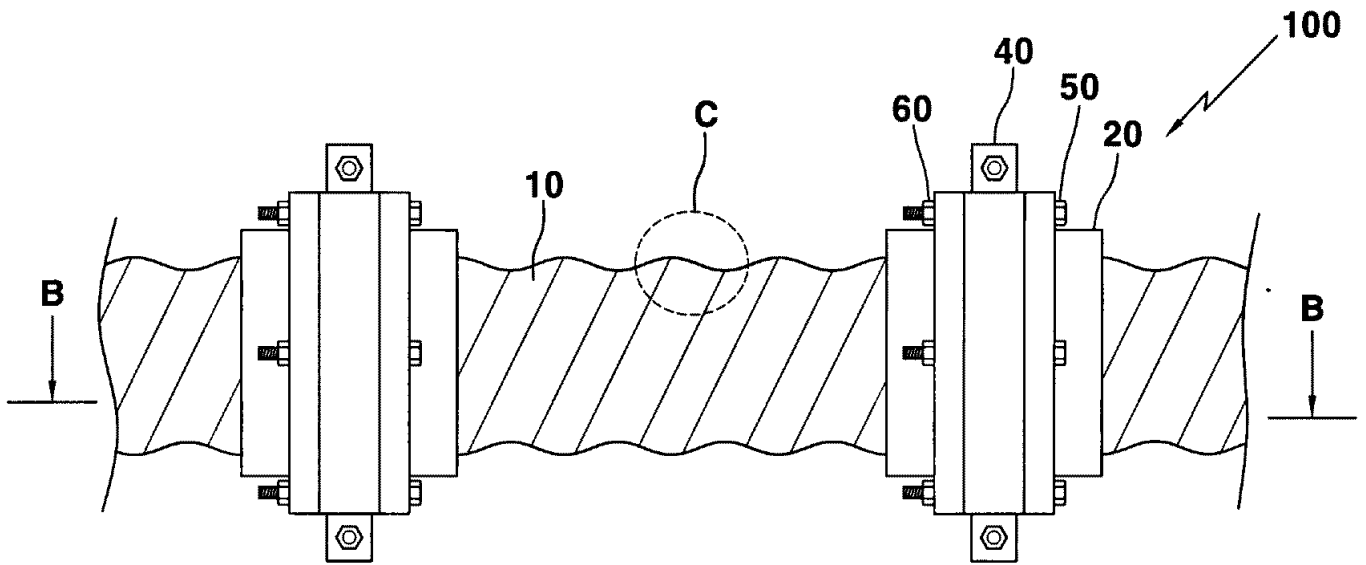

4

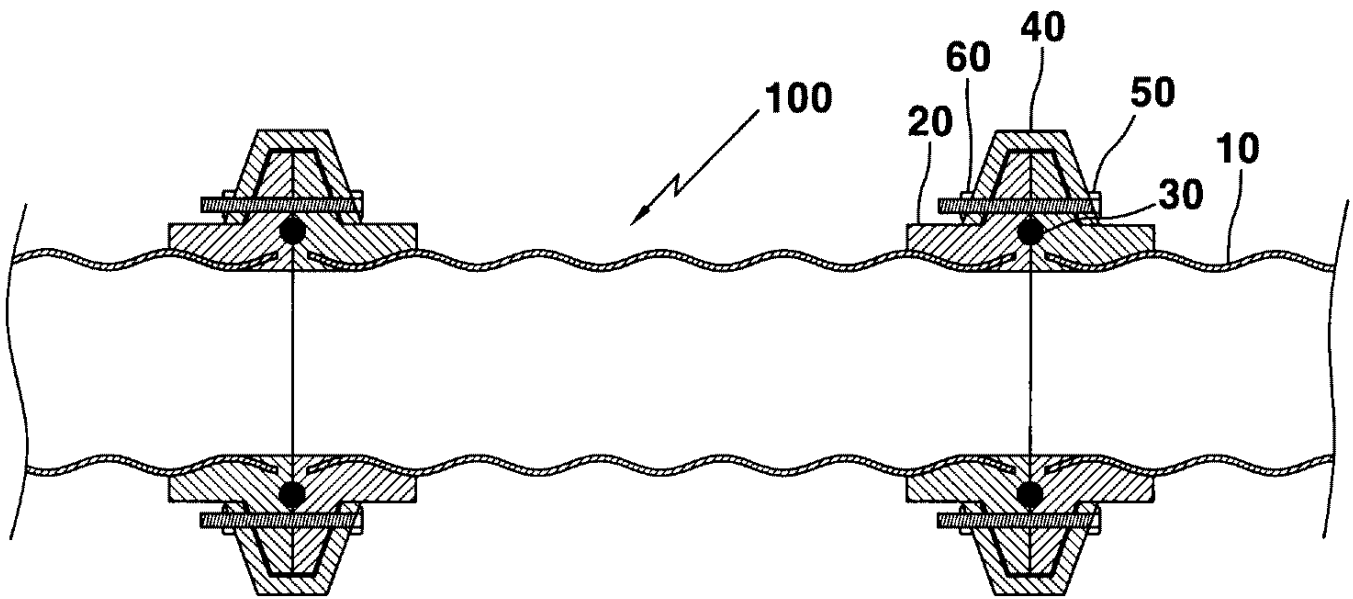

5

11

12

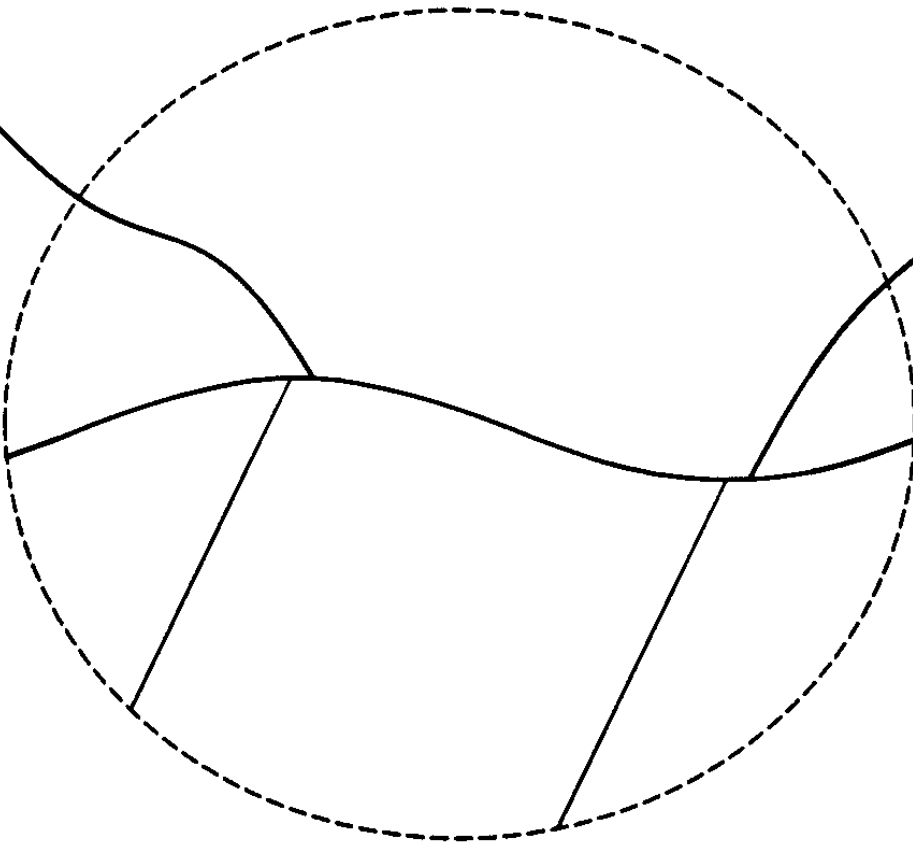

6

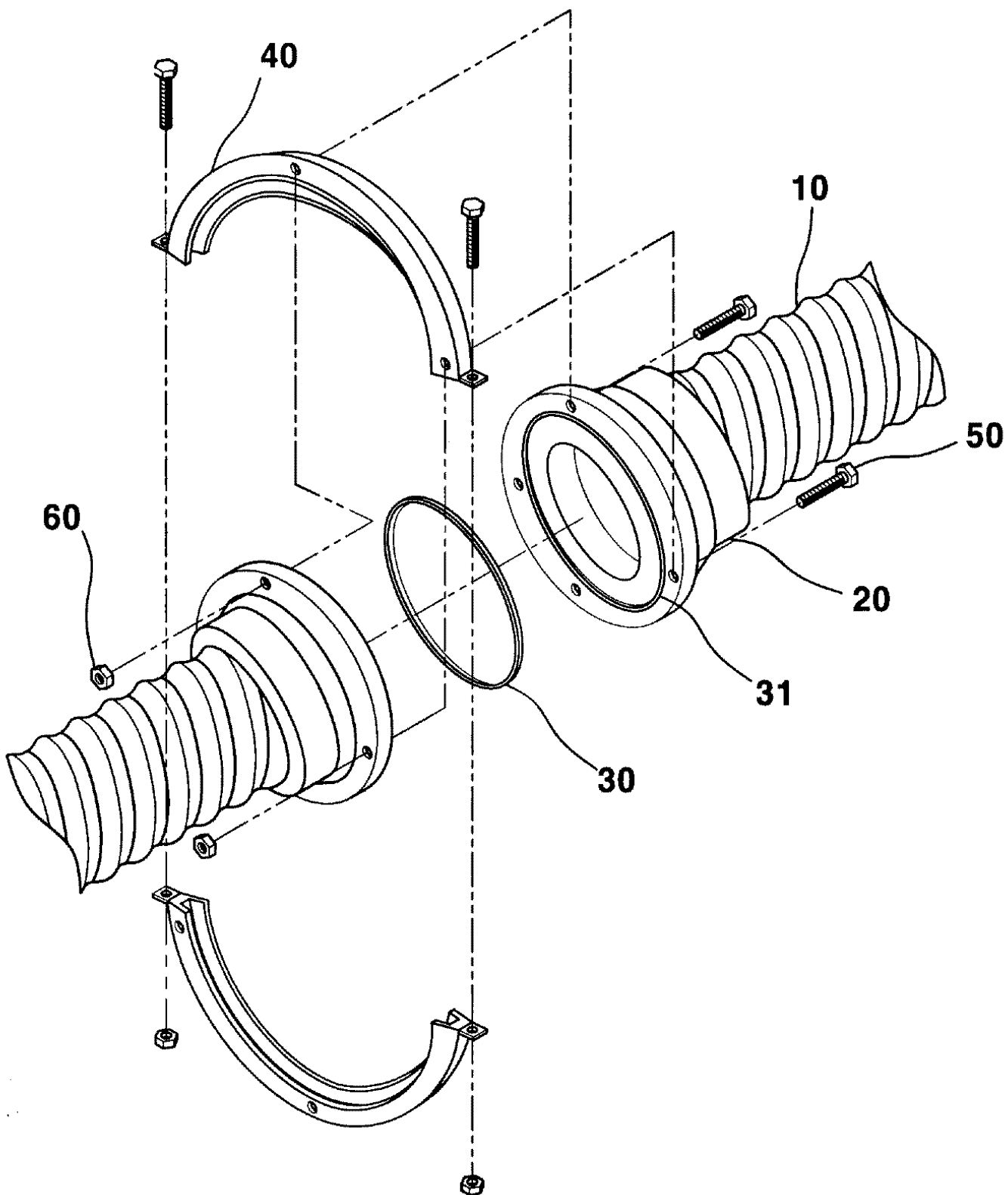

7

100

