

(12) INTERNATIONAL APPLICATION PUBLISHED UNDER THE PATENT COOPERATION TREATY (PCT)

(19) World Intellectual Property Organization
International Bureau



(43) International Publication Date
13 March 2003 (13.03.2003)

PCT

(10) International Publication Number
WO 03/020159 A1

(51) International Patent Classification⁷: **A61C 17/34**

(21) International Application Number: PCT/SE01/01872

(22) International Filing Date:
3 September 2001 (03.09.2001)

(25) Filing Language: English

(26) Publication Language: English

(71) Applicant (for all designated States except US):
NORDICA INTERNATIONAL AB [SE/SE]; Box
58, S-163 91 Spånga (SE).

(72) Inventor; and

(75) Inventor/Applicant (for US only): **EK, Peter** [SE/SE];
Stellavägen 14, S-175 67 Järfälla (SE).

(74) Agent: **EHRNER & DELMAR PATENTBYRÅ AB**;
Box 103 16, S-100 55 Stockholm (SE).

(81) Designated States (national): AE, AG, AL, AM, AT (util-
ity model), AT, AU, AZ, BA, BB, BG, BR, BY, BZ, CA,

CH, CN, CO, CR, CU, CZ (utility model), CZ, DE (util-
ity model), DE, DK (utility model), DK, DM, DZ, EC, EE
(utility model), EE, ES, FI (utility model), FI, GB, GD, GE,
GH, GM, HR, HU, ID, IL, IN, IS, JP, KE, KG, KP, KR, KZ,
LC, LK, LR, LS, LT, LU, LV, MA, MD, MG, MK, MN,
MW, MX, MZ, NO, NZ, PH, PL, PT, RO, RU, SD, SE, SG,
SI, SK (utility model), SK, SL, TJ, TM, TR, TT, TZ, UA,
UG, US, UZ, VN, YU, ZA, ZW.

(84) Designated States (regional): ARIPO patent (GH, GM,
KE, LS, MW, MZ, SD, SL, SZ, TZ, UG, ZW), Eurasian
patent (AM, AZ, BY, KG, KZ, MD, RU, TJ, TM), European
patent (AT, BE, CH, CY, DE, DK, ES, FI, FR, GB, GR, IE,
IT, LU, MC, NL, PT, SE, TR), OAPI patent (BF, BJ, CF,
CG, CI, CM, GA, GN, GQ, GW, ML, MR, NE, SN, TD,
TG).

Published:

- with international search report
- with amended claims

For two-letter codes and other abbreviations, refer to the "Guid-
ance Notes on Codes and Abbreviations" appearing at the begin-
ning of each regular issue of the PCT Gazette.

(54) Title: ELECTRIC TOOTHBRUSH

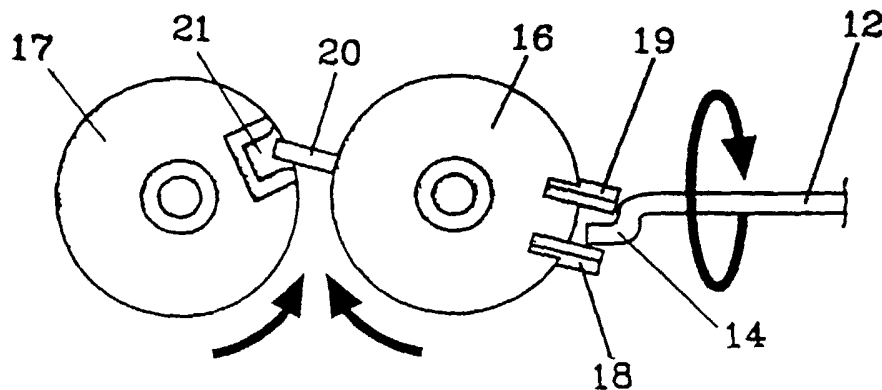

(57) Abstract: An electric toothbrush has an elongate shank (11) and a cranked drive shaft (12). A pair of pressed lugs (18, 19) are mounted on a periphery of a brush head (16) that are engaged by the shaft to cause the brush head (16) to oscillate when the shaft (12) is rotated. The brush head (16) has a rigid mechanical link that oscillates a brush head (17) in turn.



WO 03/020159 A1

ELECTRIC TOOTHBRUSH

The invention relates to electric toothbrushes.

5 Electric toothbrushes are known and widely used having a set of bristles mounted to a brush head that is driven by an electric motor inside a toothbrush handle. The motor may be powered by a battery, also inside the handle, or from a power supply socket adjacent a point-of-use. The brush heads are rotated and/or vibrated by the motor to enhance the operation of the toothbrushes for cleaning teeth. For vibrating a brush head, it is already known to provide various mechanical couplings, including gears, to convert rotational motion of the motor into oscillating motion at the brush head. Such mechanical couplings tend to be complex, possibly unreliable, or expensive.

It is an object of the invention to overcome or at least reduce such problems.

20 According to the invention there is provided an electric toothbrush having a handle and an elongate shank having a longitudinal axis, an electric motor, an elongate drive shaft rotatable about the longitudinal axis with a laterally off-set pusher at its remote end, a brush head mounted to the shank to rotate about a laterally extending axis, a pair of vertically opposed lugs at opposed sides of the longitudinal axis mounted to a periphery of the brush head for intermittent mechanical engagement by the pusher, such that when the shaft is rotated
30 by the motor the brush head is rotationally oscillated.

The lugs preferably have arcuate bearing surfaces against which the pusher intermittently bears in turn as the shaft rotates.

5 The arcuate surfaces are preferably shaped in such a manner that during each time the lugs are urged by the pusher the brush head is substantially uniformly rotationally accelerated from rest.

10 Two rotatable brush heads may be supported by the shank in which the second brush head is oscillated by a link member that extends between the said brush head to transfer oscillations for the said brush head to the second brush head.

15 The second brush head may be mounted to rotate about a substantially vertical axis that is angled to some extent with respect to the rotational axis of the said brush head.

Each of the brush heads may have a tuft block base and a re-
20 movable tuft block that releasably fits into the tuft block base.

Toothbrushes according to the invention will now be described by way of example with reference to accompanying drawings in
25 which:

Figure 1 is a sectional top plan view of the toothbrush.

Figure 2 is an isometric side view of an end of a shank of the
30 toothbrush.

Figure 3 is a schematic plan view of a rotational drive arrangement of the toothbrush.

Figure 4 is a side view of the rotational drive arrangement;
and

5 Figure 5 is an exploded view of a toothbrush head for the
toothbrush.

Figure 5a is an illustration of a preferred embodiment of the
lugs.

10

Referring to the drawings, in Figure 1 the toothbrush has a
handle 10 and an elongate shank 11 having a central longitudi-
nal axis A. A drive shaft 12 is supported to rotate about the
longitudinal axis A and is coupled to a rotor of an electric
15 motor 13 mounted inside the handle. The drive shaft has crank
14 at its remote end forming an off-set pusher. Batteries 15
are housed inside the handle 10 for supplying power to the mo-
tor 13.

20 Two in-line brush heads 16 and 17 are shown in Figures 1 and 2
vertically rotatably mounted to adjacent an end of the shank
11. It will be noted that the axis of rotation of the brush
heads are angled to some extent with one another to enable the
brushing action to move conveniently fit to a normal tooth
25 configuration of a user. The brush head 16 has two vertically
opposed lugs 18 and 19 mounted to a peripheral surface of the
brush head for engagement by the pusher 14 when the drive
shaft rotates. This causes the brush head 16 to rotationally
oscillate when the drive shaft 12 is rotated by the motor 13.
30 The brush head 16 is also provided with a rigidly connected
link 20 extending towards and into an open slot 21 in a peri-
pheral surface of the brush head 17.

The mechanical connections between the drive shaft 12 and the brush heads is clearly seen in Figures 3 and 4. When the drive shaft 12 rotates, the cranked end or pusher 14 intermittently and in turn moves the lugs 18 and 19 sideways, in opposite directions, to cause the brush head 16 to oscillate back and forth. As the brush head 16 oscillates, the link 20 moves back and forth about an arc and by engaging in the slot 21 causes the brush head 17 to oscillate. The brush heads are preferably integrally formed with stub axles 21 and 22 that have bearing surfaces and that snap fit into appropriate and respective apertures (not shown) formed in the shank 11.

In Figure 5, it will be noted that the lugs 18 and 19 are vertically opposed with facing surfaces that are arcuate. Preferably the arcuate surfaces are curved such that when the pusher 14 engages each arcuate surface, in turn, the appropriate lug is moved laterally to one respective side with a generally uniform acceleration starting from rest. This reduces noise and makes the transfer of movement between the pusher 14 and the lugs 18 and 19 more efficient.

In a preferred embodiment, shown in Figure 5a, the inner surface 30 of the arcuate lugs, against which the pusher is arranged to push, has a pusher entry side 31 and a pusher exit side 32. The entry side of the inner surface is angled outwards to some extent in respect to a plane extending through the longitudinal axis A of the elongate shank and a laterally extending axis B, when the lugs are in the position where the longitudinal axis extends in the middle of the space between the lugs. The exit side is parallel to the said plane. This reduces noise and improves the transfer of movement between the pusher 14 and the lugs 18 and 19 even further.

It will also be noted that the lug 18 is vertically lower than the lug 19 to ensure, for clockwise rotation of the pusher 14, that the pusher does not jam. For anticlockwise rotation, the lug 19 is fixed, or integrally formed, in a position appropriately lower than the lug 18. In any event, the complete vertical separation extending between the lugs 18 and 19 makes it unlikely that debris will collect or that the toothbrush cannot be easily cleaned in order to remove any debris that does collect around the pusher 14 and prevents the pusher being readily rotated to carry out its function.

Figure 5 shows that the brush head 16 (or 17) is formed in two separable parts, a tuft block base 23 and a tuft block 24. The base 23 has apertures 25 to receive integrally formed stubs 26. Raised lips 27 are formed on the inside of the base serve to overlap a peripheral skirt 28 on the tuft block to hold the tuft block down in the base 23. A recess 29 allows a blunt instrument, screw driver tip say, to enter under the skirt 28 for prising the tuft block 24 upwards over the lips 27 to facilitate removal of the tuft block when required.

It will be noted that in the described toothbrush two brush heads are used. It is possible to have only one brush head, or three or more. In the latter cases, the brush head (with lugs) is used to pass oscillatory drive to the other brush heads via suitable links 20.

The pusher 14 is provided above by a cranked end of the drive shaft 12. Other forms of pusher may be used including a short piece of shaft welded at one side to an end of a straight or uncranked drive shaft. A noncircular disc can also be used that is mounted on or integrally formed at end of the drive

shaft. A circular disc may be used where the disc is mounted off-centre adjacent the end of the drive shaft 12.

5 In an alternative embodiment the pusher is arranged to push against the outside surfaces of the lugs (18, 19), instead of the inside, in order to cause the brush head (16) to oscillate.

10 The described lugs have arcuate shaft-engaging surfaces. It will be appreciated that planar shaft-engaging surfaces may be used, although as mentioned above, such surfaces may cause more noise to be generated in operation. In this case and indeed in the described embodiment, the separation between the lugs can be relatively significant (allowing easy removal of
15 debris if required) because effective practical oscillations of the brush head overall can be achieved through an overall arc of around 20°.

20

CLAIMS:

1. An electric toothbrush having a handle (10) and an elongate shank (11) having a longitudinal axis (A), an electric motor (13), an elongate drive shaft (12) rotatable about the longitudinal axis (A) with a laterally off-set pusher (14) at its remote end, at least one brush head (16) mounted to the shank (11) to rotate about a laterally extending axis, **characterized in** that a pair of vertically opposed lugs (18, 19) at opposed sides of the longitudinal axis (A) are mounted to a periphery of the at least one brush head (16) for intermittent mechanical engagement by the pusher (14) such that when the shaft (12) is rotated by the motor (13) the at least one brush head (16) is rotationally oscillated.

15

2. An electric toothbrush according to claim 1, **characterized in** that the lugs (18, 19) have arcuate bearing surfaces against which the pusher (14) intermittently bears in turn as the shaft (12) rotates.

20

3. An electric toothbrush according to claim 2, **characterized in** that the arcuate surfaces are shaped in such a manner that during each time the lugs (18, 19) are urged by the pusher (14) the brush head (16) is substantially uniformly rotationally accelerated from rest.

25

4. An electric toothbrush according to claim 1, **characterized in** that it includes two rotatable brush heads (16, 17) supported by the shank (11) in which the second brush head (17) is oscillated by a link member that extends between the brush heads (16, 17) to transfer oscillations for the brush head (16) to the second brush head (17).

30

5. An electrical toothbrush according to claim 4, **characterized in** that the second brush head (17) is mounted to rotate about a substantially vertical axis that is angled to some extent with respect to the rotational axis of the said brush head (16).

6. An electrical toothbrush according to any of claims 1 to 5, **characterized in** that each of the brush heads (16, 17) have a tuft block base (23) and a removable tuft block (24) that releasable fits into the tuft block base.

AMENDED CLAIMS

[received by the International Bureau on 16 March 2002 (16.03.02);
original claim 1 amended; remaining claims unchanged (1 page)]

1. An electric toothbrush having a handle (10) and an elongate shank (11) having a longitudinal axis (A), an electric motor (13), an elongate drive shaft (12) rotatable about the longitudinal axis (A) with a laterally off-set pusher (14) at its remote end, at least one brush head (16) mounted to the shank (11) to rotate about a laterally extending axis, a pair of opposed lugs (18, 19) connected to the at least one brush head (16) for mechanical engagement between them by the pusher (14) such that when the shaft (12) is rotated by the motor (13) the at least one brush head (16) is rotationally oscillated, **characterized in** that the lugs (18, 19) protrude from the periphery side of the brush head (16) and form a slot which is perpendicular to the drive shaft (12).

2. An electric toothbrush according to claim 1, **characterized in** that the lugs (18, 19) have arcuate bearing surfaces against which the pusher (14) intermittently bears in turn as the shaft (12) rotates.

3. An electric toothbrush according to claim 2, **characterized in** that the arcuate surfaces are shaped in such a manner that during each time the lugs (18, 19) are urged by the pusher (14) the brush head (16) is substantially uniformly rotationally accelerated from rest.

4. An electric toothbrush according to claim 1, **characterized in** that it includes two rotatable brush heads (16, 17) supported by the shank (11) in which the second brush head (17) is oscillated by a link member that extends between the brush heads (16, 17) to transfer oscillations for the brush head (16) to the second brush head (17).

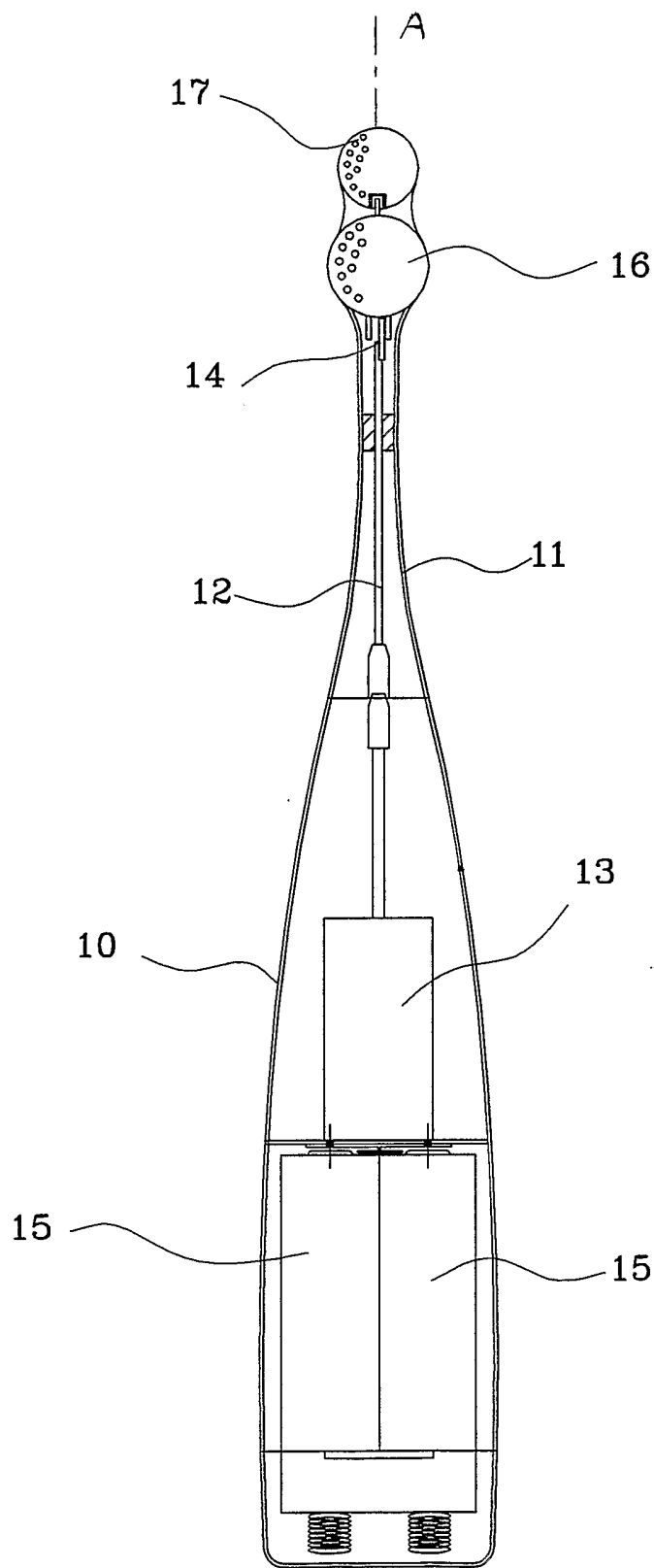

Fig. 1

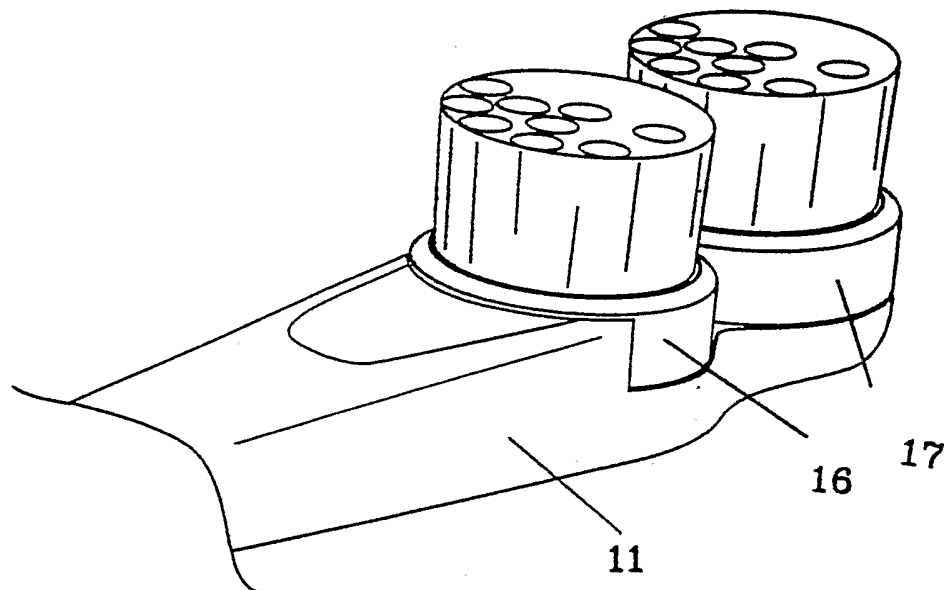

Fig. 2

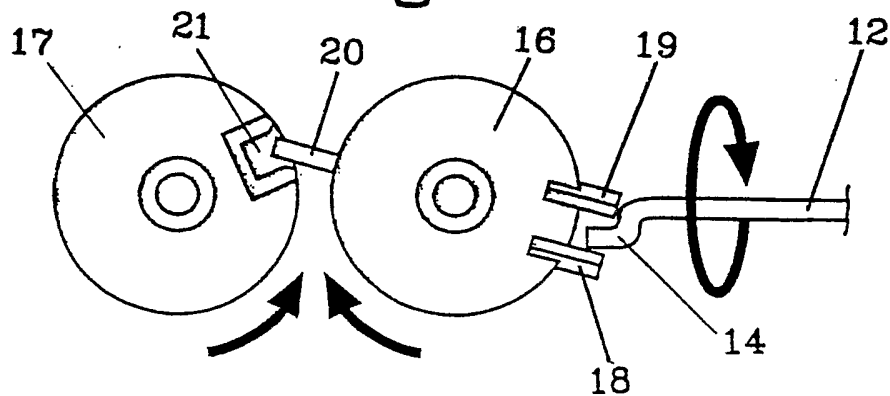

Fig. 3

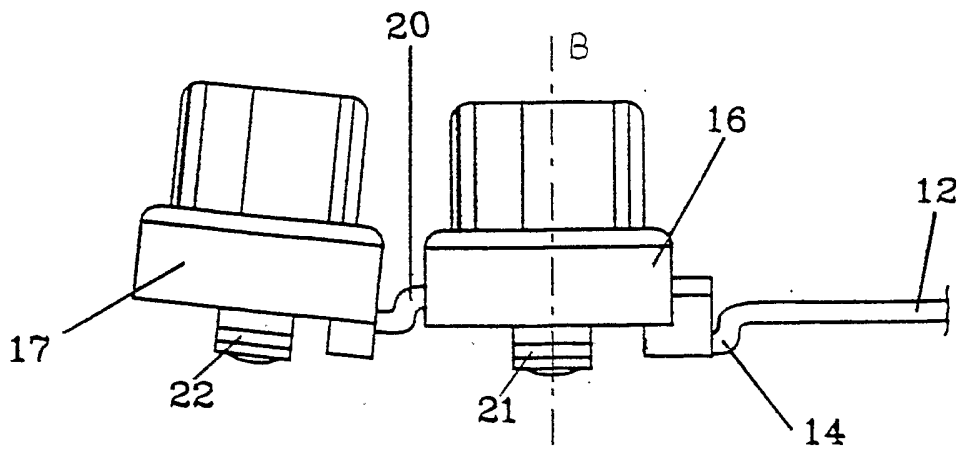
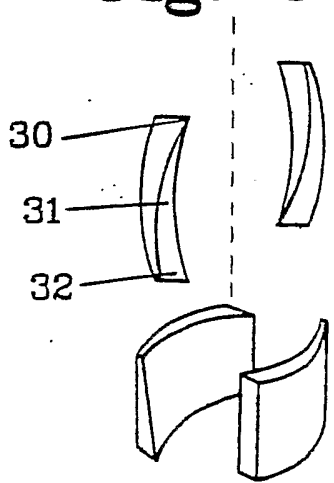
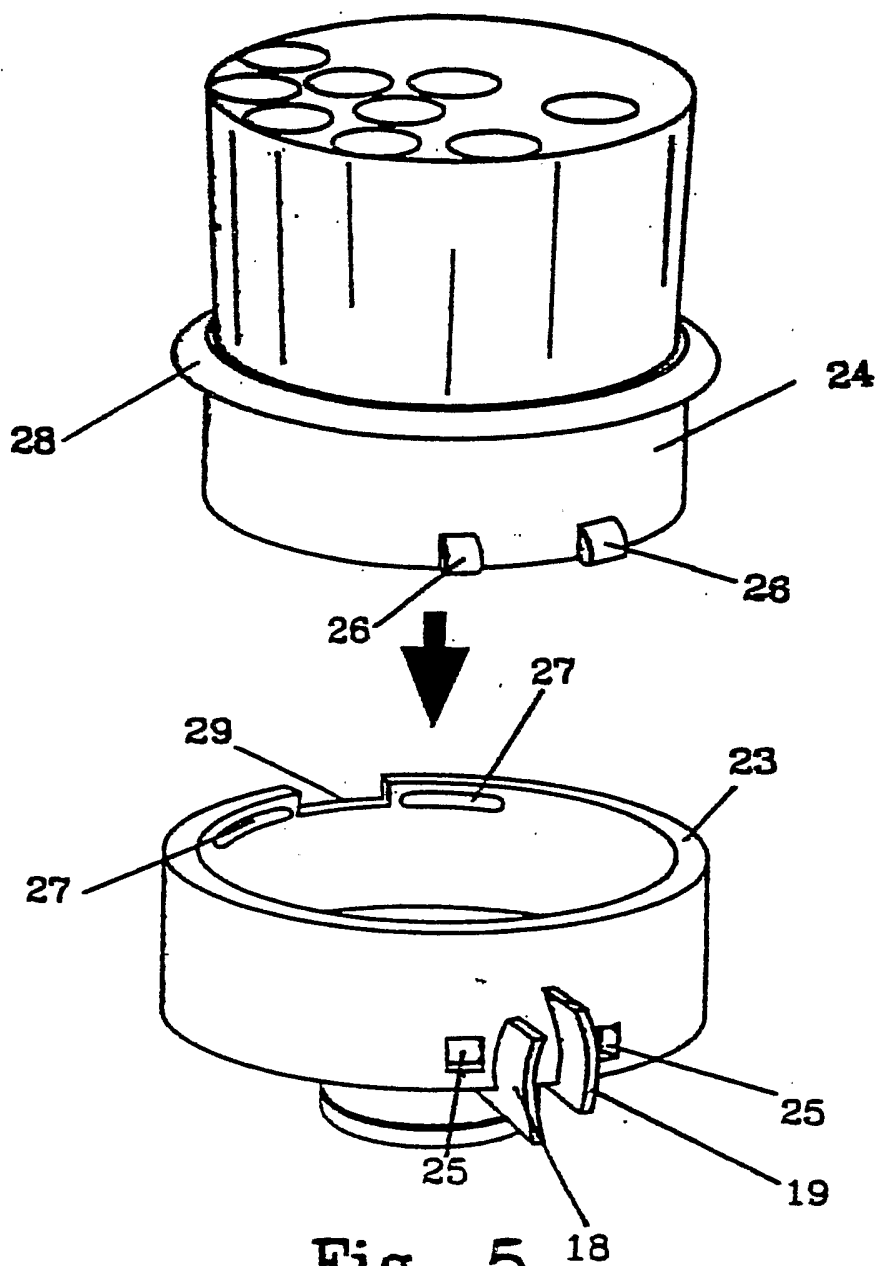

Fig. 4



INTERNATIONAL SEARCH REPORT

International application No.

PCT/SE 01/01872

A. CLASSIFICATION OF SUBJECT MATTER

IPC7: A61C 17/34

According to International Patent Classification (IPC) or to both national classification and IPC

B. FIELDS SEARCHED

Minimum documentation searched (classification system followed by classification symbols)

IPC7: A61C

Documentation searched other than minimum documentation to the extent that such documents are included in the fields searched

SE,DK,FI,NO classes as above

Electronic data base consulted during the international search (name of data base and, where practicable, search terms used)

C. DOCUMENTS CONSIDERED TO BE RELEVANT

Category*	Citation of document, with indication, where appropriate, of the relevant passages	Relevant to claim No.
X	US 5784743 A (SHEK), 28 July 1998 (28.07.98), figures 1-4, claims 1-6 --	1-6
X	US 200010004781 A1 (BLAUSTEIN ET AL), 28 June 2001 (28.06.01), figures 4-6, claims 1-27 --	1-6
A	US 5876206 A (MAURER), 2 March 1999 (02.03.99), figures 1-13, claims 1-18 --	1-6
A	US 5504958 A (HERZOG), 9 April 1996 (09.04.96), figures 1-4, claims 1-10 -- -----	1-6

 Further documents are listed in the continuation of Box C. See patent family annex.

* Special categories of cited documents:

"A" document defining the general state of the art which is not considered to be of particular relevance

"E" earlier application or patent but published on or after the international filing date

"L" document which may throw doubts on priority claim(s) or which is cited to establish the publication date of another citation or other special reason (as specified)

"O" document referring to an oral disclosure, use, exhibition or other means

"P" document published prior to the international filing date but later than the priority date claimed

"T" later document published after the international filing date or priority date and not in conflict with the application but cited to understand the principle or theory underlying the invention

"X" document of particular relevance: the claimed invention cannot be considered novel or cannot be considered to involve an inventive step when the document is taken alone

"Y" document of particular relevance: the claimed invention cannot be considered to involve an inventive step when the document is combined with one or more other such documents, such combination being obvious to a person skilled in the art

"&" document member of the same patent family

Date of the actual completion of the international search

18 December 2001

Date of mailing of the international search report

16-01-2002

Name and mailing address of the ISA/

Swedish Patent Office

Box 5055, S-102 42 STOCKHOLM

Facsimile No. +46 8 666 02 86

Authorized officer

Agneta Änggård/EK

Telephone No. +46 8 782 25 00

INTERNATIONAL SEARCH REPORT

Information on patent family members

06/11/01

International application No.

PCT/SE 01/01872

Patent document cited in search report	Publication date	Patent family member(s)	Publication date
US 5784743 A	28/07/98	NONE	
US 200010004781 A1	28/06/01	NONE	
US 5876206 A	02/03/99	AT 175565 T AU 6281194 A CN 1105173 A DE 59407638 D EP 0645988 A,B SE 0645988 T3 JP 7507956 T WO 9423667 A	15/01/99 08/11/94 12/07/95 00/00/00 05/04/95 07/09/95 27/10/94
US 5504958 A	09/04/96	AT 167043 T DE 4343103 A DE 59406204 D EP 0663192 A,B	15/06/98 22/06/95 00/00/00 19/07/95