

(19)
(12)

(KR)
(Y1)

(51) 。 Int. Cl. ⁷
H01R 11/01

(45)
(11)
(24)

2001 07 31
20 - 0231277
2001 05 03

(21) 20 - 2001 - 0004461
(22) 2001 02 21

(73) 123 - 2 1/3

(72) 123 - 2 1/3

(74) :

가 :

(54)

가 , 가 1 , 가
가 1 , 가
가 , 가

1 ,
 2 ,
 3 1 | - | ,
 4 1 ,
 5 가 ,
 6 1 ,
 7 6 1 ,
 8 ,
 9 8 ,
 10 .

* *

10 : 100 :
 110 : 111 :
 112 : 114 :
 115 : 118 :
 120 : 1 121a : 1
 121b : 2 122 : 1
 123 : 2 124 :
 128 : 129 :
 130 : 132 :
 140 : 142 :
 144 : 1 145 : 2
 144a : 1 145a : 2

147 : 150 :

160 : 170 : 2

180 :

(' ') , (' ') 가
 .
 가
 2000 - 0022600 (2000. 04. 25) “ 가 ”
 , 가 .

(IDC : Insulation Displacement Connection)

가
 ” , 95 - 0031531 “ (IDC)
 , 가
 .
 가
 가

가 , 가 , 가
 , 1 , 1
 , 가 1 1
 , 가 , 가
 가 , 가

2 1 , 1 1 2 1 가 가 ,
 , 1 1 2 1 2 1 1
 1 2 2 1 2 2 1 1 1
 2 2 2 2 1 2 1
 가 , 1 1 2 1 2 2 1 1
 , 1 3 11-1 , 4 1 , 2 , 5 가
 1 5 (110) 가 (100) (110)
 (rib, 112)가 (111) (111)
 (113) , 1 (120)
 (114) (115) , (110) 4 5
 (10) (116) (117)가 (110)
 (118)가
 (110) 1 (120) 1 (120) (114)
 (110) (129) (132) (121) (121) (121) (121)
 128) (120) (121) , 1
 (121) 4 1 (121a) 2 (121b)
 , 2 1 (122) 1 (122)
 2 (123) 2 (123)
 1 (122) 2 (123) (124)

1 (121a) 1 (121a) 1 (121a) 1 (122)
 1 (121a) 1 (121a) 2 (121b)
 1a) 1 (120) 1 (121a) 1 (122)
 (121) 1 (121a) 1 (121a)
 2 (123) 2 (121b) 1 (122) 1 (121a)
 (121) 1 (122) 2 (123) (121)
 (140) 1 (120)

(128) (121) (121) 가
 (110) (128)

(129) (130) (132)
 1 (120)

118) (110) (130) (130) (
 (132) 1 (120) 가

1 (120) (100) (140) (140)
 가 (111) (112)
 (121)가 (142)
 1 (121a) 2 (121b) (140)
 140) 1, 2 (121a, 121b) (
 1 (144) 1 (144)
 (121)가 (142) 가
 1 (144) 2 (145)

(100) (150) (150) (115)
 (140) (110) 1 (120)
 1 (144) 2 (145) (150) (140)가
 1 (144) 2 (145) 1 (150) (121)
 (122, 123) (20) 1 (120) (121)

3 (110) (113) (160)가 (160)
 1 (120) (160)

(100) 5 (10) (117)
 (130) (132)

1 1 (144) 2 (145) (150) (140)
 1 (144) 2 (145) 1 (120) (121)
 (122, 123) , (122, 123) 1 (120) (121) 가 .

6 1 , 7 6 1

6 1 (120) (121) , 1
 (122) 2 (123) (124) , (121)
 (128) , (129) 1 (120) , 1
 (120) (121) , (140) , 1 (144)
 2 (145) (147) (150) (110) .

8 , 9 8

8 9 1 (120) 2 (170)
 (130) , 1 (120) (128) 2 (170) (110)
 (180) , 가 (180) (100) (132)
 , 가 , 가

1 5

10

10 (140) 1 (144) 2 (145)
 44a) 2 1 (144a) 2 (145a) , 1 (1
 (145a) , ,

가

가 가

가 , , 가 가

(57)

1.

가 가 ; 가 가 ; 1 ; 1 ; 가 가 ; ;

2.

1 , 2 , 1 1 2 1 가 가 , 1

3.

1 2 , 1 1 2 1 가 가 , 2 1 1 1 1 1 2 2 1 1 2 2

4.

1 2 , 1 2 2 1 1 2 1 가 1 2 1 2

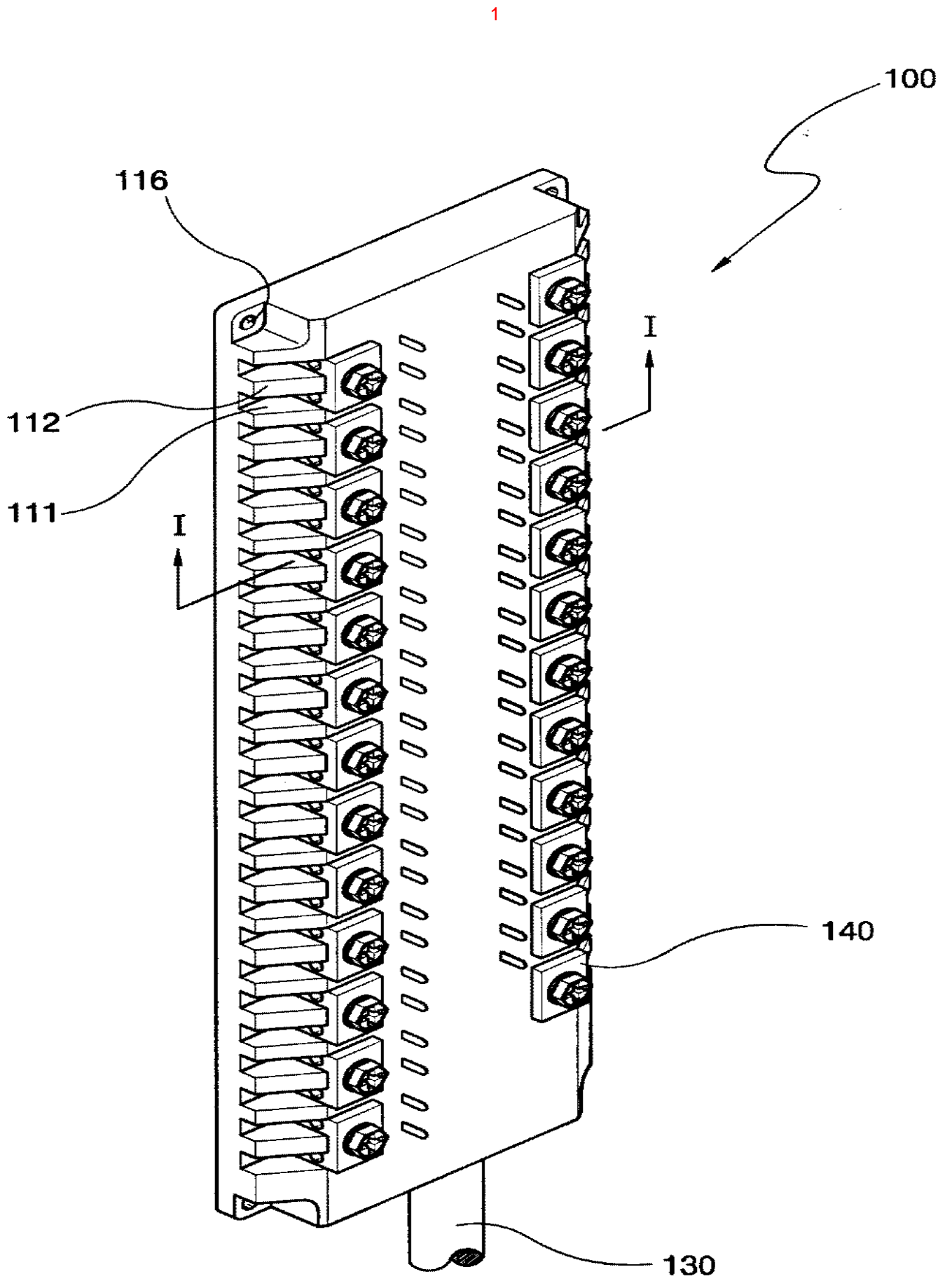

3

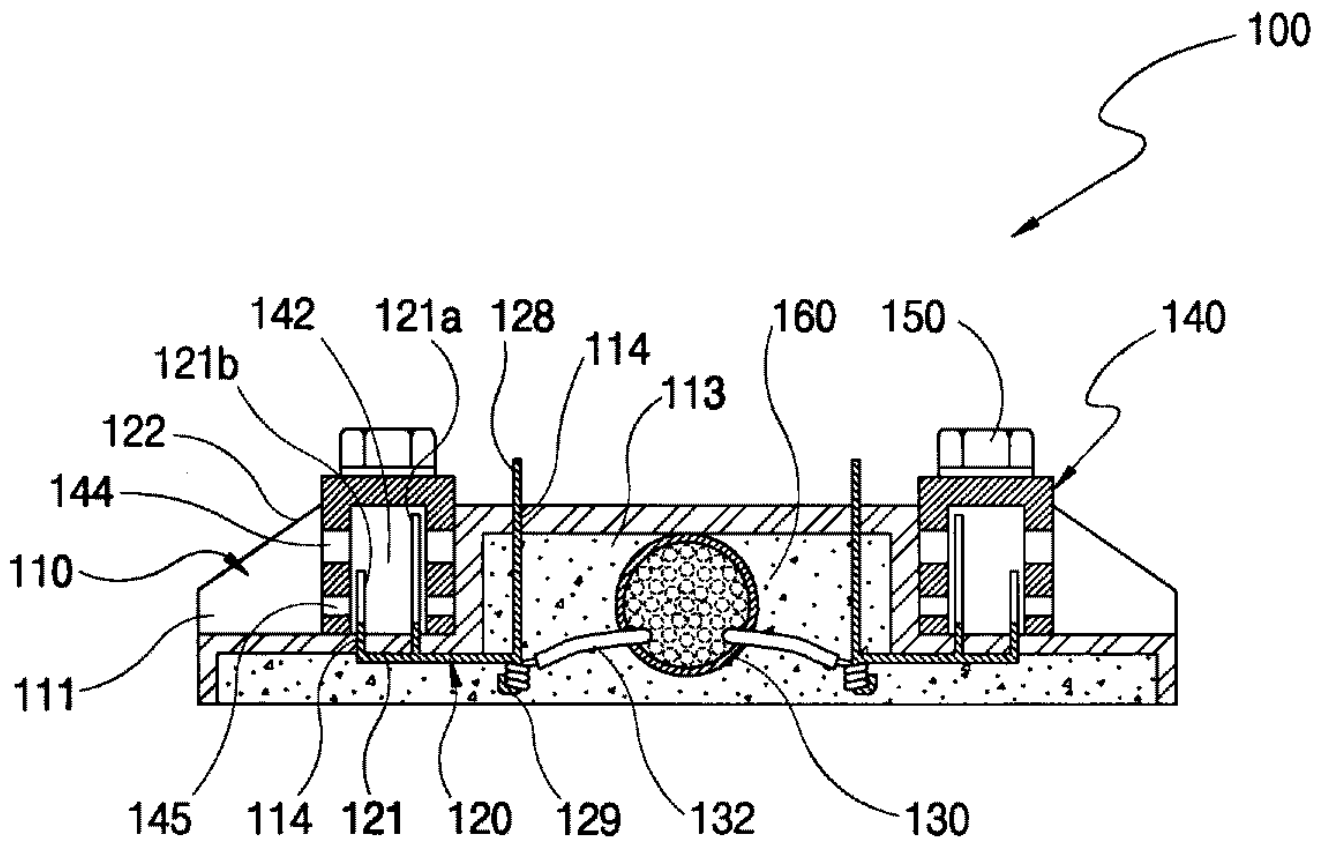

4

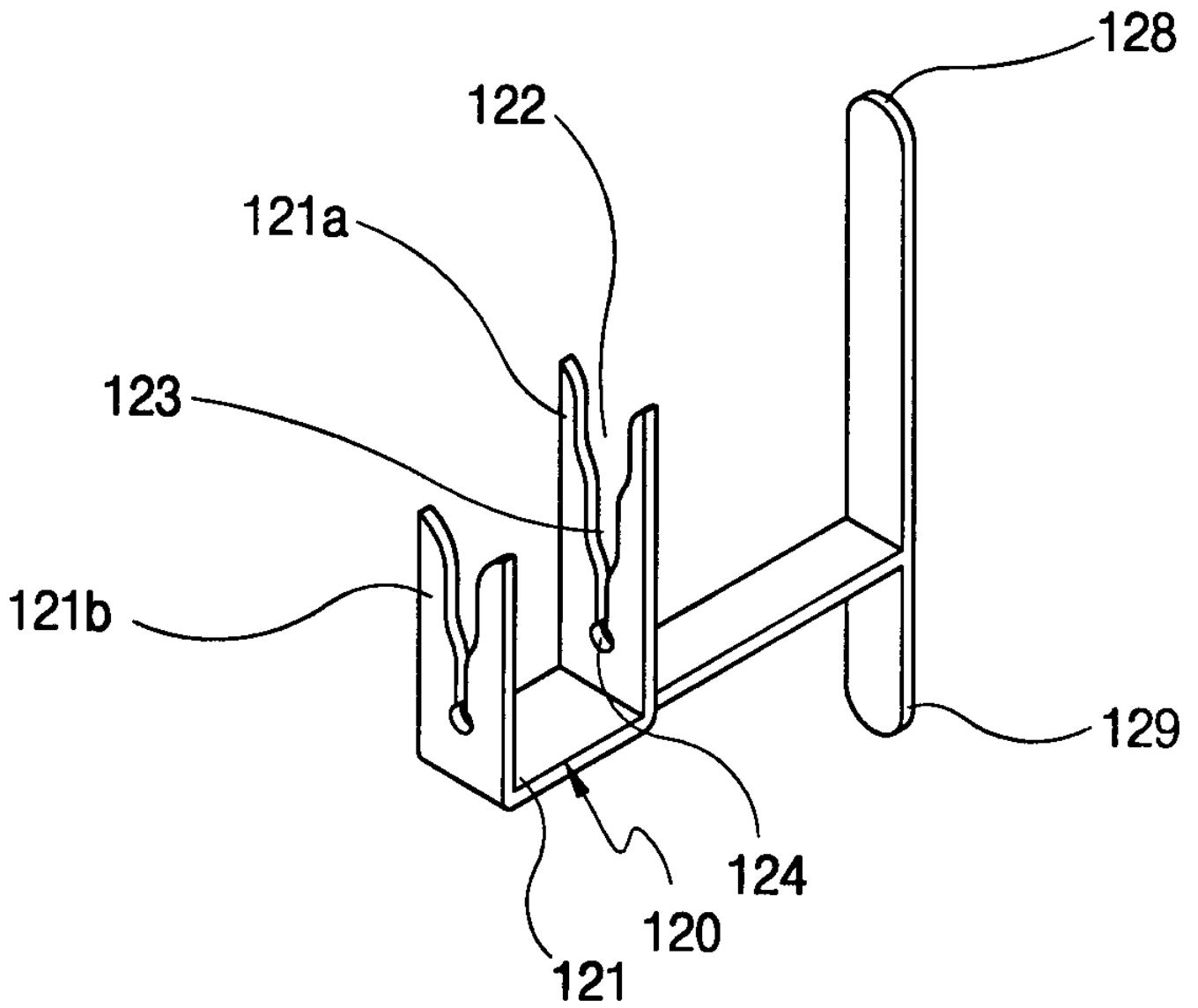

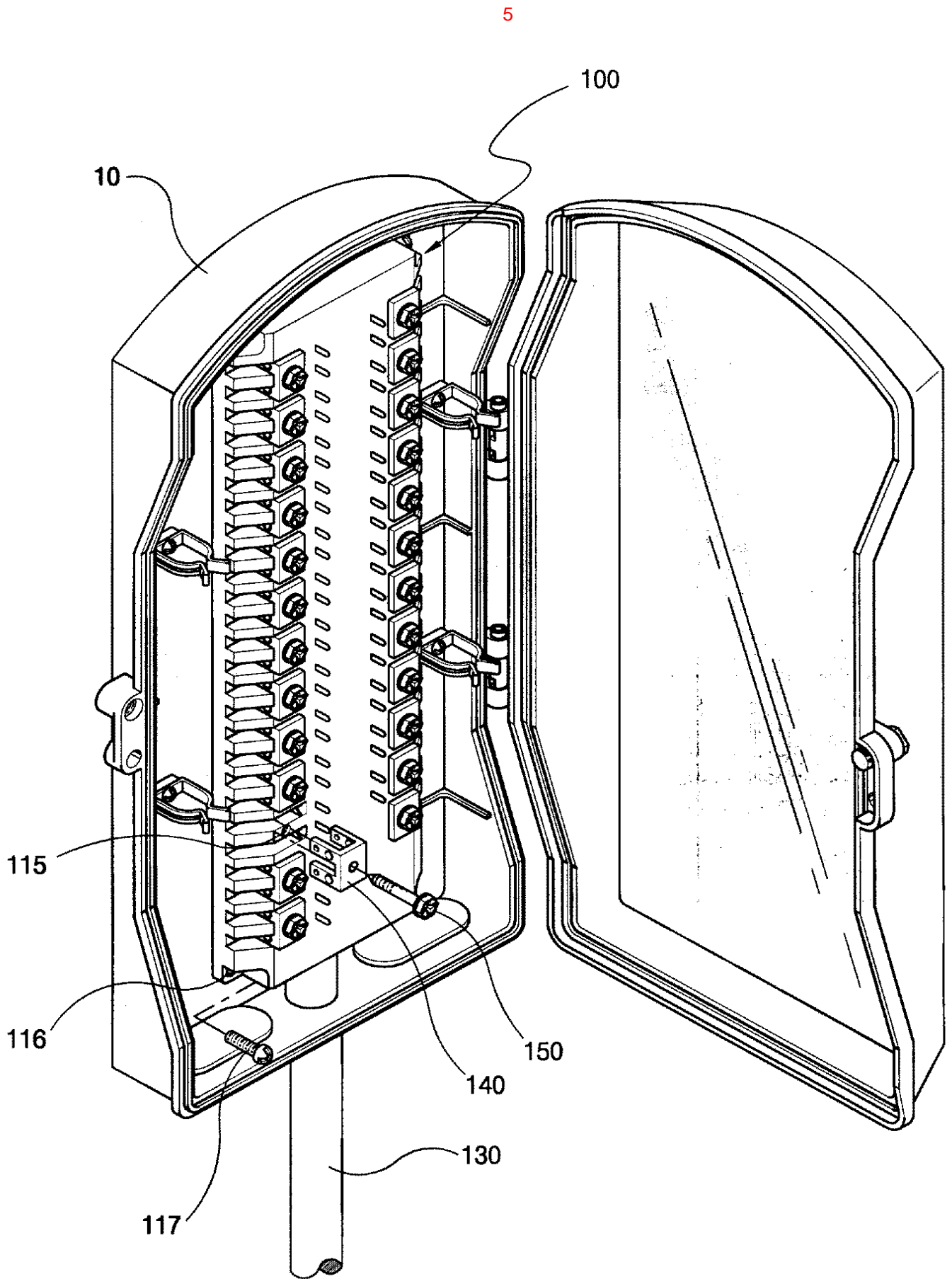

6

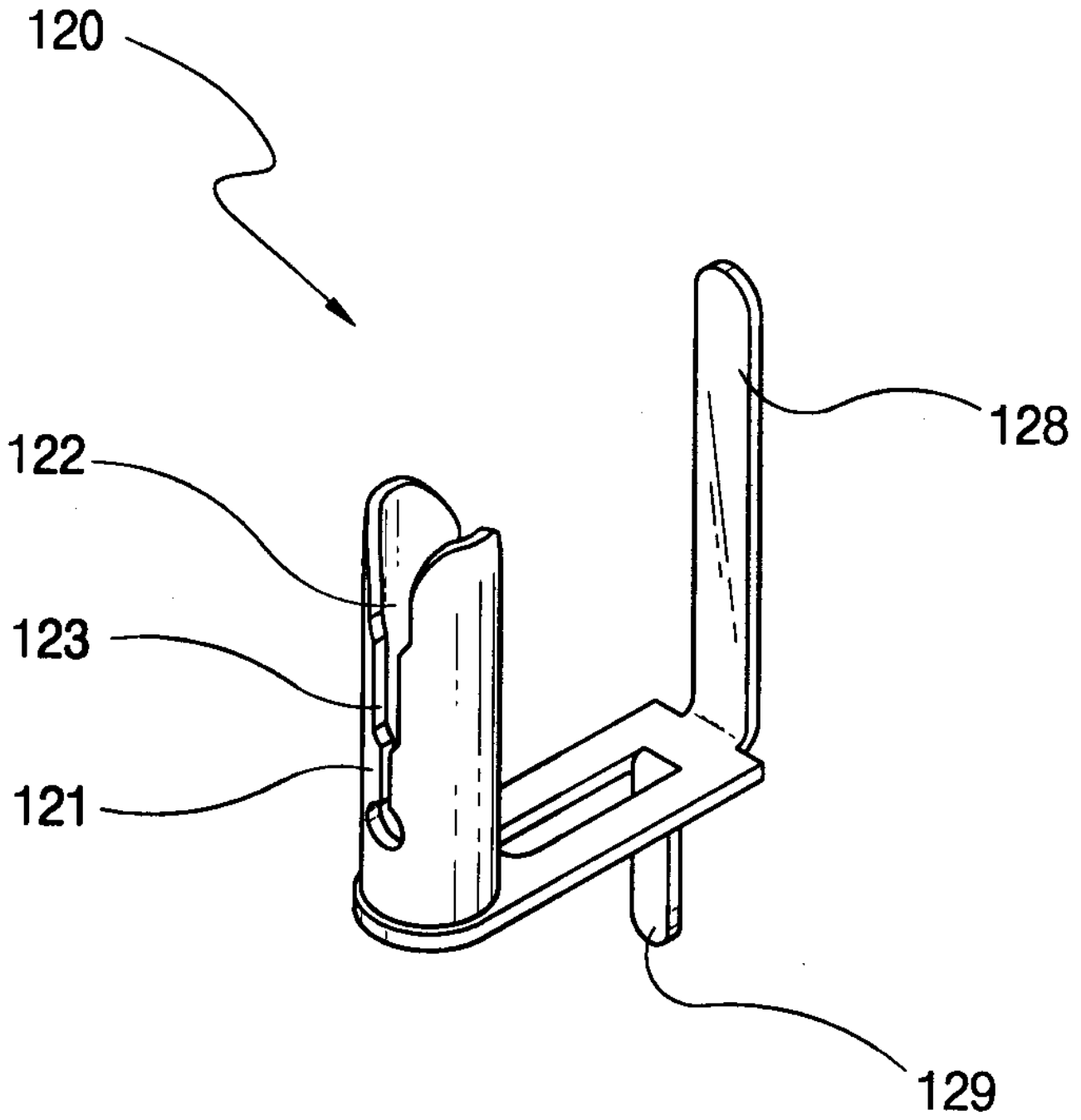

7

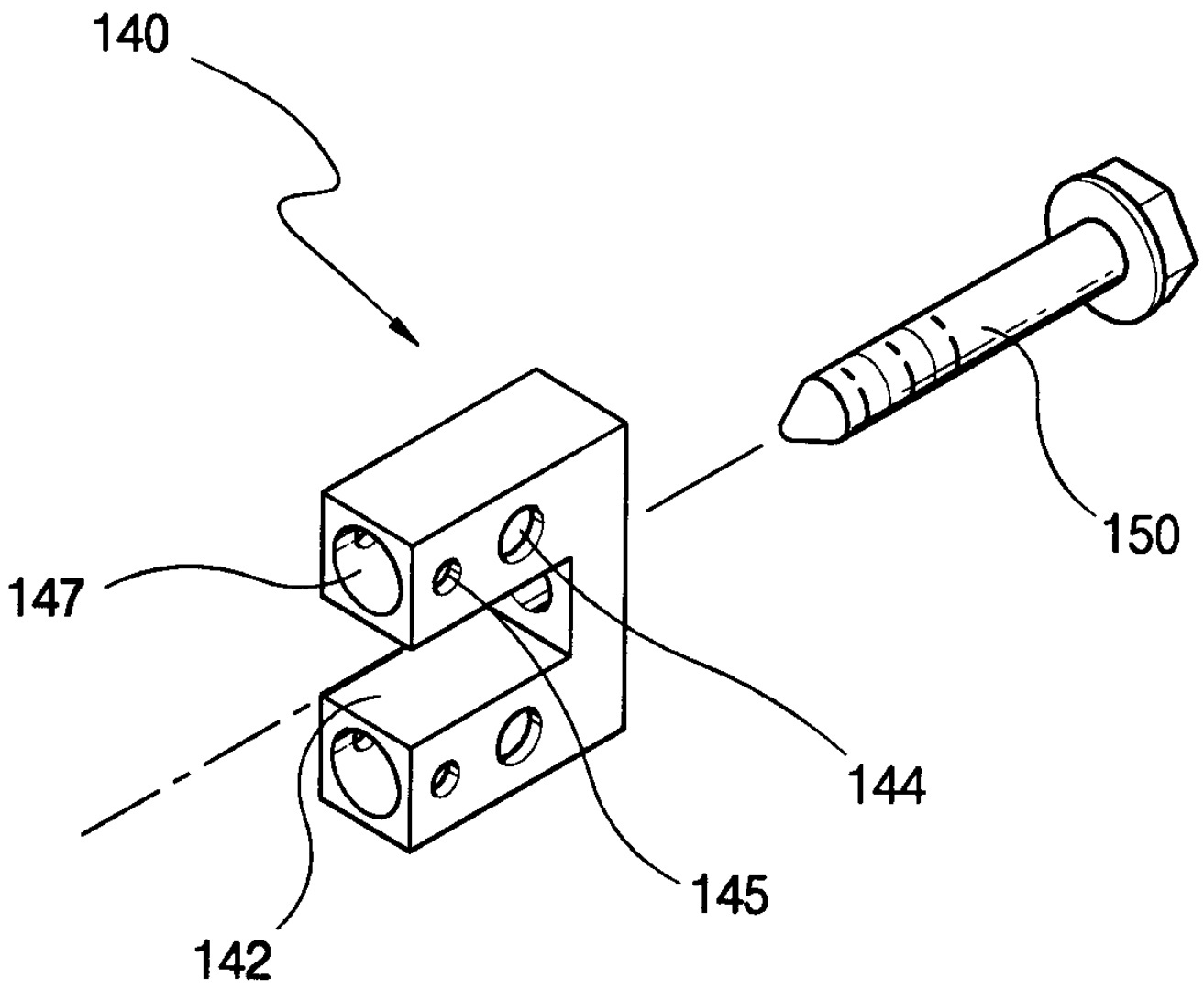

8

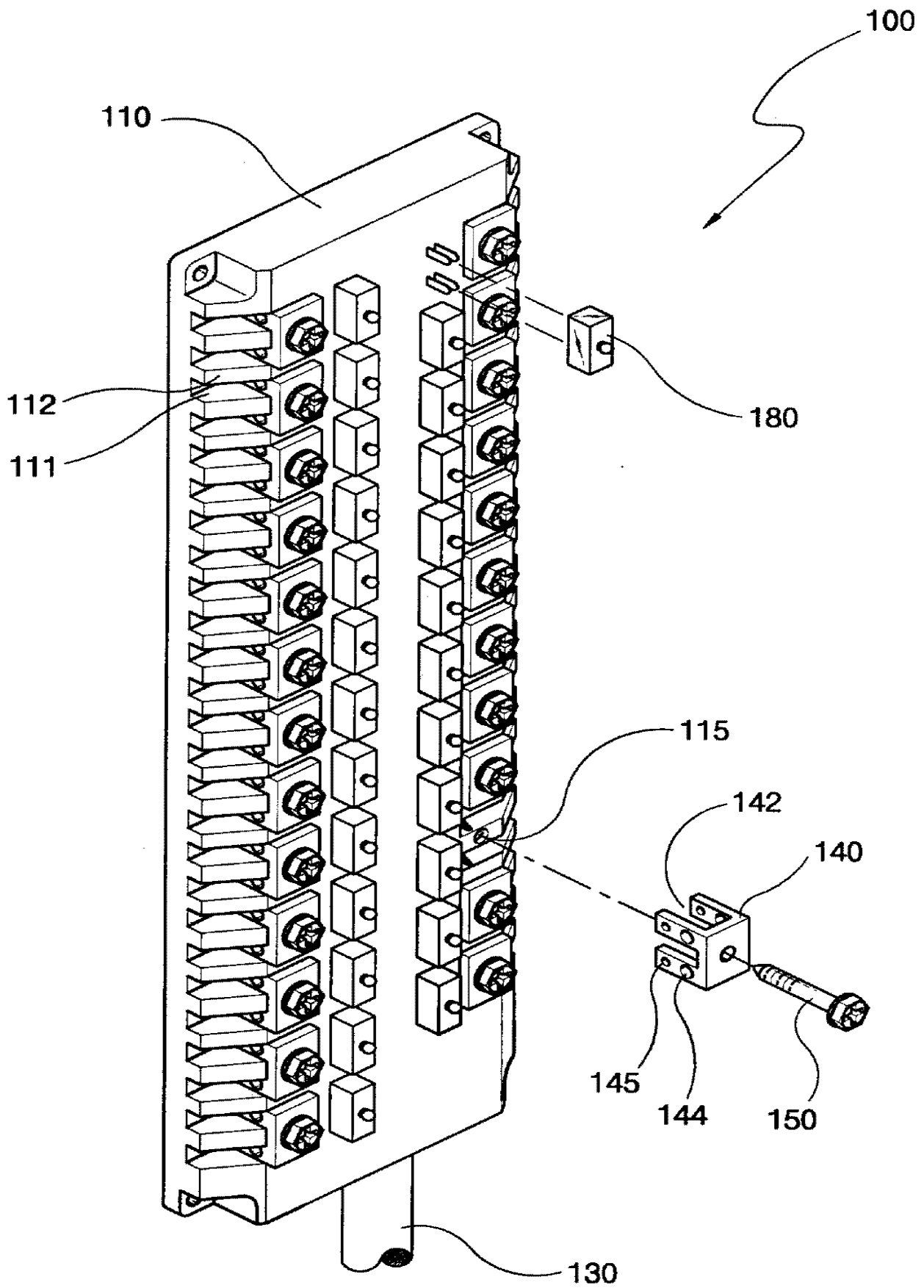

9

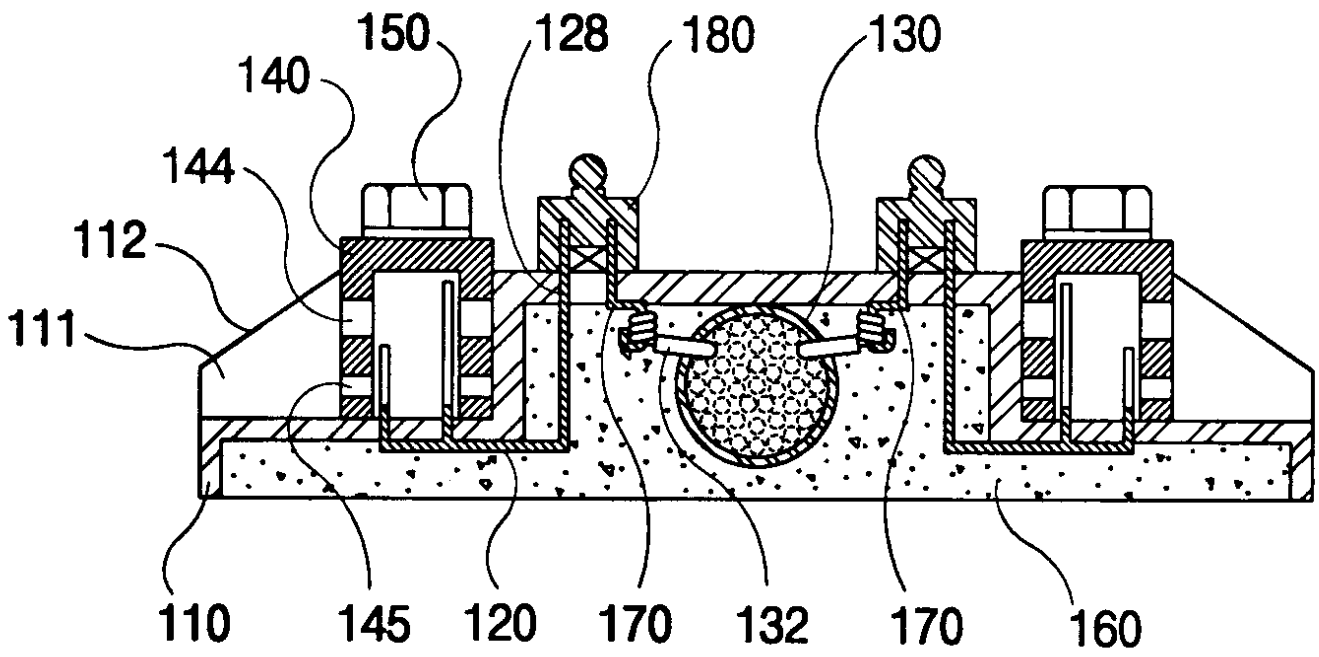

10

